

MISTRAL

ROAD SWEEPER

FAYAT



Location of main features

- ① Water tank.
- ② Access cover, pneumatic and electronic cabinet.
- ③ Access cover, auxiliary engine fuel and hydraulic filling.
- ④ Storage locker.
- ⑤ Side loading hatch.
- ⑥ Door open/close ram.
- ⑦ Vehicle fuel tank, orientation is dependant on chassis.
- ⑧ Access ladder to auxiliary engine.
- ⑨ Low pressure pump and valves.
- ⑩ Central brush (wide sweep) assembly.



- ⑪ Low pressure and/or high pressure front spray bar.
- ⑫ Shut off valve high pressure front spray bar.
- ⑬ Hydraulic oil and auxiliary engine water cooler location.
- ⑭ Access cover, pneumatic valve block.
- ⑮ Auxiliary hand pump.
- ⑯ Side brush assembly.
- ⑰ Suction nozzle assembly.
- ⑱ High pressure hose reel, orientation dependant on chassis.
- ⑲ Rear door locking mechanism.

Mistral

Operating Instructions

Incorporating Basic Operator Maintenance Information

Part No. SCAZ037980

Version: 8.0.00 12 February 2024

This manual is published by the Technical Publications Department of Scarab Sweepers Ltd. and every effort is made to ensure that the information it contains is correct at the time of publication. Due to a policy of continuous development, however, the Company reserves the right to alter the specification and to supply when so altered without reference to illustrations and descriptions in this manual.

Scarab Sweepers Limited
Pattenden Lane, Marden, Kent TN12 9QD, England
T: +44 (0)1622 831 006
E: scarab@scarab.fayat.com -W: scarab-sweepers.com
Registered in England No.1823459 - VAT No. GB 374 5002 68
Registered Office: Pattenden Lane, Marden, Tonbridge, Kent TN12 9QD, England

General Information

Typical weights, dimensions and capacities

Gross vehicle weight (GVW) *	10 to 15 tonne
Overall height (hopper lowered) *	3000 to 3500mm
Maximum height (hopper raised) *	4500mm
Overall length *	6000mm
Overall width (brushes stowed) *	2500mm
Gross hopper volume	6.2m ³

Tank capacities *

Chassis fuel tank *	Typically 100 to 150 litres
Auxiliary engine fuel tank *	117 to 135 litres
Hydraulic oil tank *	51-56 litres
Water tank	1250 litres

Noise levels

In cab	Between 70 - 84 dB(A) dependent on operating speed
External	Maximum LWA of 114 dB(A) in accordance with directive 2000/14/EC

Vibration

All dynamic prime moving components are resiliently mounted to minimise vibrations. In accordance with 2006/42/EC as amended

Whole body	Equipment does not exceed 0.5 m/s ² (RMS, weighted)
Hand & Arm	Equipment does not exceed 2.5 m/s ² (VTV)

* Dimensions given are for general guidance only and are subject to chassis type used. For specific chassis related details please contact the Sales Department.

Cummins auxiliary engine

This manual does not cover the Cummins QSB 3.3 Tier 3A auxiliary engine. Information such as the User Manual is available as a free download from the following web site:

<https://quickserve.cummins.com/info/index.html>

Identification plates

The SERIAL NUMBER PLATE is located on the rear face of the left hand suction nozzle spigot.

The Serial Number will comprise four numerical digits only (for example 5843).

For the location of the vehicle's VIN PLATE and CHASSIS NUMBER, refer to the chassis manufacturers' documentation.

Limitations of use

The Scarab Mistral is classified as truck-mounted heavy-duty suction road sweeper and, as such, is intended only for operation in the sweeping and associated roles for which it has been expressly designed.

Applicability

This manual covers the operating requirements of the Scarab Mistral sweeper with the CANbus 3 operating system.

Warnings

Starting engine



Voltage sensitive components.

Do not use a boost start/super start. A boosted start will burn out the vehicles electronic control nodes.

If batteries are not charged then always use a fresh set.

Electrical equipment



CB Radios and other electrical equipment used in the sweeper should be properly suppressed (EMC) to prevent the possibility of interference in the sweeper electronic system.

Towing



Serious damage to the transmission could result if the vehicle is towed while gearbox is engaged.

If towing is necessary, it is imperative that the prop shaft is disengaged from the differential or that the rear wheels are clear of the ground before making any attempt to tow the vehicle

Table of contents

<i>Description</i>	<i>Page</i>
Location of main features	2
General Information	4
Warnings	6
Table of contents	7
Health and safety advice	11
Hazard awareness	13
Safety precautions	14
Operating advice	15
Safety props	16
Door safety prop	16
Auto ratchet hopper safety prop	16
The CANbus system	17
Main control panel switch functions	18
Auxiliary control panel switch functions	19
Remote control switch box functions	20
LCD Monitor	21
Additional controls and instruments	22
Brush pressure	22
Overhead wander boom	22

- Operating in sweep mode 23
 - Starting the auxiliary engine 23
 - Operational modes and engine speed: 23
- Sweeping 24
- Exiting sweep mode/stopping the auxiliary engine 25
- Engaging the reduction gearbox (scarab option only) 25
- Disengaging the reduction gearbox (scarab option only) 25
- Discharging the hopper - tipping 26
- Using the auxiliary hydraulic pump 27
- Standard wander hose 28
 - Using the standard wander hose 28
- Rear mounted wander hose and overhead wander boom 29
 - Using the rear mounted wander hose 29
 - Using the overhead wander boom 29
- Dust suppression 30
 - Filling the water tank 30
 - Using the low pressure water system 30
- High pressure water system 31
 - Using the high pressure water system 31
 - Hand lance detergent option 32
 - Retractable hose 32
- Clearing a blockage in the suction path 33
- Operator’s routine maintenance 34

Key maintenance procedures	36
Cleaning the suction fan and screen	36
Auxiliary engine	37
Engine oil	37
Topping up	37
Engine coolant	38
Topping-up	38
Hydraulic oil tank	39
Topping-up	39
Oil tank components	39
Suction nozzle clearances	40
Side brushes	41
Side skirts	41
Removing and cleaning the water filter element(s)	42
Manual greasing and lubrication	43
LCD monitor - Options screen	44
Button function	44
Option screen menu description	44
Hours worked	45
Driver fault codes	45
CAN error screen	46
Driver fault codes	46
EDC	47
Screen settings	47
Screen brightness setting	48
Time and date setting	48
Rear camera	49

Information	49
Button check menu	50
Main control panel button check	50
Auxiliary control panel button checks	51
Operator's notes	52

Health and safety advice



In the interests of your health and safety, it is important that the following points are observed at all times.

- Only trained operatives should be allowed to drive or work on this sweeper.
- Before driving the sweeper ensure all relevant sweeper checks have been carried out and that all equipment has been stowed.
- Do not overload the hopper.
- Do not drive the sweeper with the hopper in the raised position, even if the hopper is empty.
- Never work under a raised cab, hopper or rear door unless the appropriate safety prop is in the deployed position.
- Before operating either the hopper tip or rear door controls, ensure that there is sufficient clearance and that it is safe to do so. Ensure all personnel are clear of the rear door.
- Before working on the sweeper:
Position the sweeper on firm, level ground, apply the handbrake, stop both engines and remove the ignition key.
- Always wear the appropriate personal protection equipment (PPE) when operating or working on the sweeper.
- Before starting the engines ensure that all controls are switched and the sweeper is in neutral.
- Keep long hair, loose clothing and hands away from moving parts.
- High pressure water can be hazardous, always wear suitable face protection when operating the high pressure pump and when using the lance. Do not direct the water jet at other persons.
Beware of electrical installations on public building and lamp posts etc. Always exercise extreme caution in public places.
- The driver's seat should be correctly adjusted before driving as to give a good posture when driving.
- The mirrors should be adjusted so the driver has a good all round view of the sweeper sides and sweeping equipment.
- When operating the sweeper in any mode always be aware of objects and people in the immediate vicinity, especially at the rear of the sweeper when reversing.
- Whatever the situation, remember that the rules of traffic and road safety must be observed.
- While operating this sweeper the safety and well being of others are the sole responsibility of the operator.
- Never ride on any other part of the sweeper other than the seats in the drivers cab.



The universal safety symbol along with red text is used throughout this handbook and when encountered the related information must be adhered to.



Refers to important information.



Identifies cautionary information and specific procedures when required.

 Refers to visual examination to confirm the condition or status of a specific item.

 *Other symbols, not shown here, maybe used throughout this handbook and must be observed when encountered.*

 **Remember, failure to comply can result in serious injury.**

Hazard awareness

All operators and workshop personnel should be aware of the physical and biological risks that are inherent in the operation of a road sweeper. The risk falls into two main categories as follows:

- Risks represented by the sweeper and its various systems.
- Risks represented by the sweeper's operating environment.

Both have the potential for exposure to a variety of hazards, ranging from hot surfaces to infectious diseases, that can occur during day-to-day operation, while carrying out adjustments or when involved with the general maintenance and servicing activities on the vehicle.

Typical vehicle-related hazards are:

- Exposure to hot surfaces and sharp edges.
- Exposure to moving parts.
- Exposure to various fluids (including some hot and/or pressurised).

Exposure to surface contamination resulting from general operating conditions.

Typical environmental hazards are:







- Exposure to sharp objects (e.g. broken glass, discarded hypodermic syringes) while operating or working on the vehicle.
- Exposure to various infectious diseases (e.g. Legionnaire's, Weil's, Hepatitis, Tetanus) while operating or working on the vehicle.

Safety precautions

When using external equipment such as the high-pressure water lance, or when dealing with potentially hazardous situations while sweeping (e.g. unblocking a suction nozzle), always wear the appropriate Personal Protection Equipment (PPE) and exercise extreme caution if required to handle any of the material being swept.

Before working on the vehicle, subject it to a thorough steam cleaning or high-pressure hot water wash using appropriate detergents etc.

Even after taking all reasonable steps to reduce the risk from the hazards described, always wear the appropriate Personal Protection Equipment (PPE) when carrying out sweeping duties or when working on the vehicle. This includes:

-  *Eye/Face protection, including where necessary full-face mask with under-chin lip.*
-  *Safety Gloves, including where necessary cut-resistant knitted Kevlar.*
-  *Safety boots or shoes with protective soles and toecaps.*
-  *Earplugs or Ear defenders as appropriate.*
-  *High visibility clothing as required.*
-  *Overalls or coveralls.*

Operating advice

Please remember, the information provided in this handbook is designed to ensure that the Scarab sweeper operates both safely and efficiently.

The design of this sweeper is for the removal of spoil on traffic or pedestrian areas also litter collection using the wander hose.

A poorly maintained sweeper will become unreliable, inefficient and potentially dangerous. Always observe the recommended maintenance and safety related advice provided.

 *Unless it is wet or raining, always use the low-pressure water spray system when sweeping. This will not only reduce the amount of dust generated, it will also ensure more efficient collection of material. This is because wet material is heavier and will drop more readily from the air stream inside the hopper. If swept dry more of the finer material will pass through the screen, wearing out the fan blades on its way back to the environment behind you.*

Operators should be trained in the following elements:

- Health and safety observations/notices
- Transit driving
- In-cab and external controls
- Hopper safety/door prop use
- Brush setting
- Nozzle flap adjustment
- Correct sweeping operations
- Low and high pressure water systems
- Load discharge (tipping)
- Daily, weekly maintenance schedules
- End of day cleaning, i.e. suction fan, fan screen and sweeper body

Operator training can be provided by Scarab Sweepers upon request.

 **The LCD monitor's USB connection is for uploading/downloading information (ONLY) and must not be used for any other purpose.**

 *It is the responsibility of employers to carry out their own risk assessment for the sweeper, operators or other persons using or affected by the sweeper and equipment.*

Various safety, hazard and user information labels are fixed to the sweeper. These must be observed.

Only personnel qualified in the relevant disciplines should be allowed to work on any of the sweepers hydraulic system.

For information regarding vehicle operation and maintenance, refer to the chassis manufactures handbook.

Door safety prop

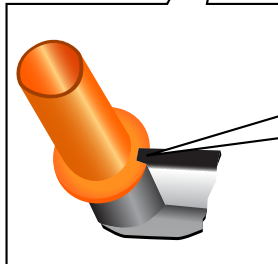
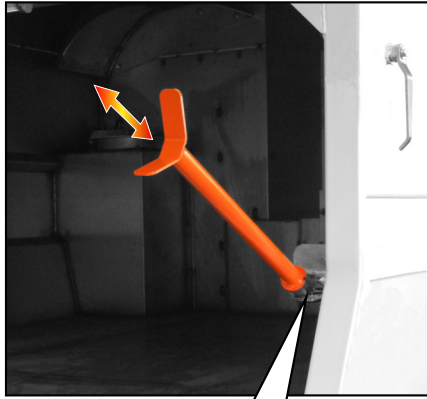

When inserting the door safety prop, ensure it is correctly positioned in the locating slot.

Auto ratchet hopper safety prop



Ensure that the safety prop is correctly positioned in the ratchet.

The CANbus system

The CANbus system comprises two control panels (main and auxiliary) an LCD monitor and a number of control nodes. The system controls and monitors all sweeper functions and maintains a log of various operating parameters such as operating hours and any fault conditions that might occur.

Switches: The various types of switch function are colour coded as follows:

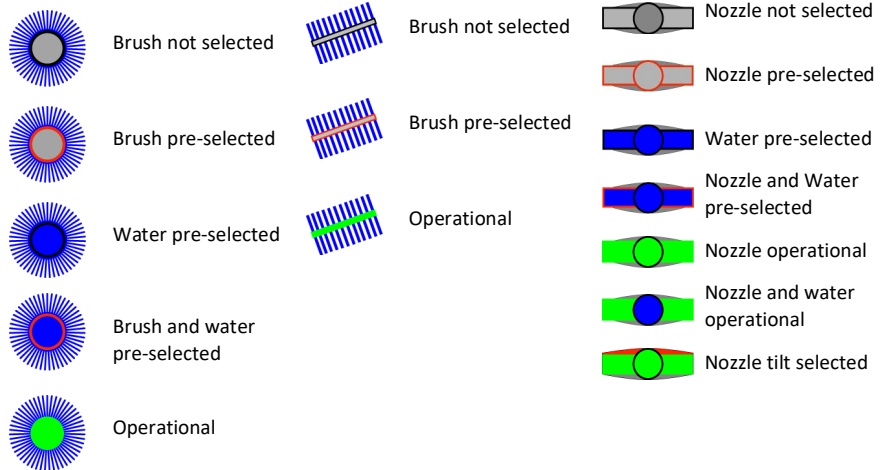
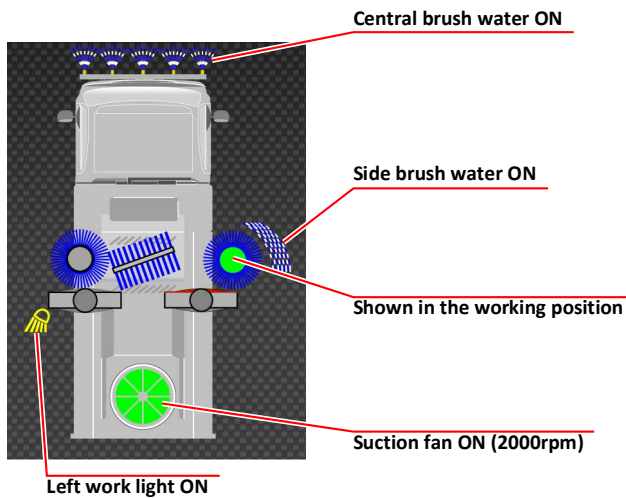

- RED** = Critical functions, Sweep Mode ON/OFF.
- AMBER** = Electrical functions such as lighting.
- GREEN** = Sweeping functions.
- BLUE** = Water Spray functions.

Each switch illuminates a function-related symbol on the LCD monitor (only installed equipment will be displayed). Each symbol is greyed-out until its switch is activated. When a switch is activated the appropriate symbol will illuminate according to system status as illustrated.





Main control panel switch functions



 Switch functions are described from left to right and top to bottom.



  **F1 / F2** - Press to activate special options.

 **System-Start** - Press to start/stop the system and engage/disengage hydrostatic drive.

 **Brush speed (-)** - Press to decrease brush speed. Remembers speed set until reset.



 **Brush speed (+)** - Press to increase brush speed. Remembers speed set until reset.

  **Left/right side brush** - Press to start the side-brush.



  **Left/right suction nozzle raise/lower** - Press to lower the suction nozzle.



 **Central (wide sweep) brush** - Press to start the central (wide sweep) brush.

  **Left/right work light** - Press to turn ON.

  **Left/right side brush/nozzle water** - Press to start the side-brush and suction nozzle dust-suppression.







 **Central (wide sweep) water** - Press to start the dust-suppression spray for the central (wide sweep) brush.

  **Increase/reduce auxiliary engine speed** - Press and hold down to reduce/increase the speed of the Auxiliary engine. A single press of the either switch will adjust engine speed by 50 RPM. Current engine speed is displayed along the top of the LCD monitor.

  **Left/right suction nozzle additional water** - Press to start the additional water jets for the suction nozzle.



Auxiliary control panel switch functions

-  **High pressure water pump** - Press to start.
-  **Suction fan** - Press to start the Suction Fan (approximately 2000 rpm).
-  **Cruise control** - Not applicable.
-  **Nozzle tilt (locking mode)** - Press to tilt the suction nozzle for larger items.
-  **Suction fan 'boost'** - With the Suction Fan ON, press to activate the fan boost mode. This increases fan speed to approx. 2200 rpm.
-  **Favourite setting** - Press to memorise your preferred sweeping set-up. Hold the switch down until a 'beep' sounds. Thereafter, whenever the switch is pressed at system start-up, the memorised configuration will be automatically pre-selected/restarted. Repeat to over-ride with a new configuration.

Multi function lever - ON (deploys all selected sweeping equipment). To stop and raise all sweeping equipment, return the lever to the OFF position. In the ON position the lever can be used to control the side brushe(s) and suction nozzle(s). These additional positions i.e. Left, Right and Back, return to the central position when released.

The brush and nozzle functions are controlled as follows:

On left hand drive vehicles

Move the lever to the left to swing OUT, and to the right to swing IN the side brush(es).
On sweepers fitted with variable extend and retraction, move the lever momentarily in the desired direction to 'nudge' the brush(es)

On right hand drive vehicles

Move the lever to the right to swing OUT, and to the left to swing IN the side brush(es).
On sweepers fitted with variable extend and retraction, move the lever momentarily in the desired direction to 'nudge' the brush(es)

Nozzle tilt function

Move the lever back to momentarily tilt the suction nozzle or close it from TILT OPEN position.
On sweepers with variable nozzle-tilt, move the lever back to 'nudge' the suction nozzle DOWN from the TILT OPEN position.



Remote control switch box functions

The hopper Raise/Lower and rear door Open/Close switches are located in the remote control box. This is stowed in the cab, between the driver's seat and door and is connected to a socket via a coiled lead.

⚠ In the interest of health and safety and to avoid possible damage to the sweeper or adjacent structures, it is essential that the remote hopper/door controls are not activated from within the cab. Always use these controls outside of the vehicle from a vantage point that affords a good view of the sweeper and its immediate surroundings.

The hopper prop must always be in the deployed position when the hopper is in the raised position. Failure to do could result in serious injury. The door prop must always be used when working under a raised rear door.



Hopper raise - Press and hold down to raise the hopper.



Hopper lower - Press and hold down to lower the hopper.



Rear door open - Press and hold down until the door is Fully open (at approximately 90° to the rear face of the hopper).

Ensure that the suction fan is OFF. The door cannot open while the fan is running due to the low pressure created within the hopper.



Rear door close - Press and hold down until the door is fully closed and the latching cycle has finished. Door cannot be closed until hopper has been fully lowered.



Option

Safety interlock

This switch must be pressed in and held before any of the control switches are operated.

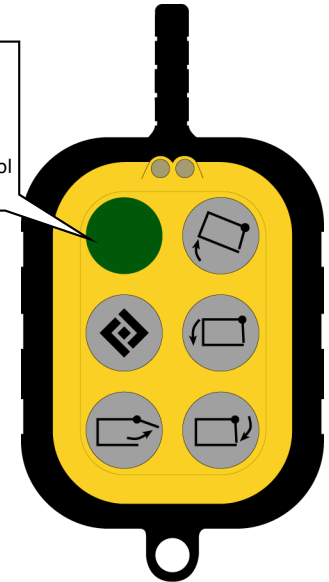

LCD Monitor

The sweeping monitor displays information on the current status of the sweeper while it is in sweep mode, by indicating which items of equipment are active, plus other relevant information i.e. fluid levels, fan speed and temperatures, it also alerts the user to any warnings by means of appropriate flashing symbols and, when appropriate, a warning buzzer. For warnings identified by , stop and investigate the cause. The accompanying illustration shows the range of information/alert symbols that can be displayed, however it should be noted that warning symbols (*) only illuminate when a specific condition occurs.

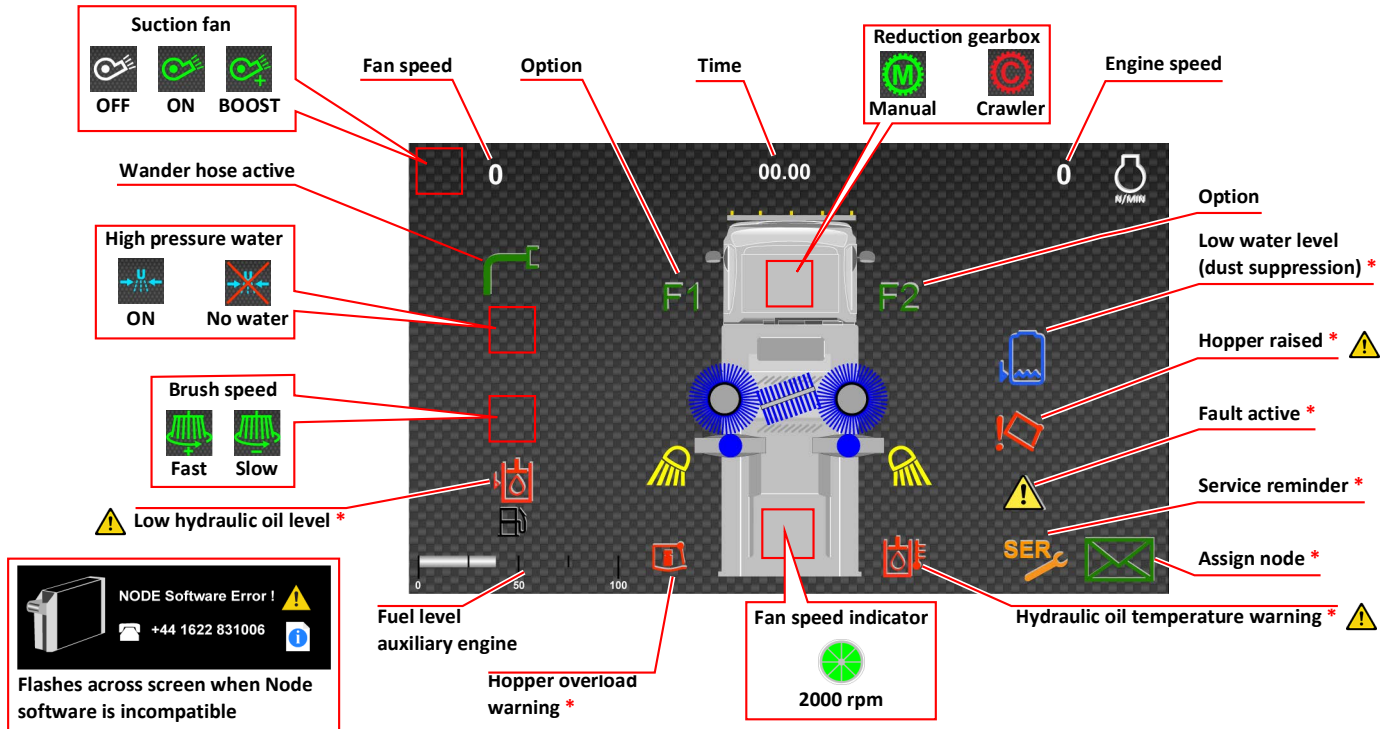

Additional controls and instruments

Brush pressure

⚠ Do not exceed a pressure of 2.5 bar when adjusting brush pressure settings. Failure to comply will result in drastically reduced brush life.

- ① - Air pressure regulator - Used to adjust the amount of up/down-thrust applied to the brush(es) **⚠**.
- ② - Air pressure gauge - Indicates the amount of pressure being applied to the brush(es) **⚠**.
- ③ - Central (wide sweep) brush switch - Turns function ON/OFF.
- ④ - Side brush switch - Turns function ON/OFF.

⚠ This function is only effective while the relevant brushes are fully deployed

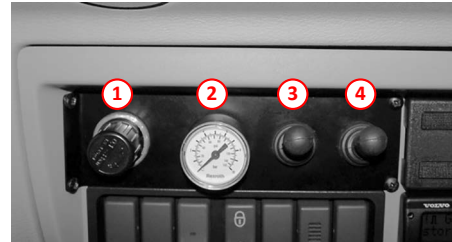

Typical layout of controls mounted in the dash

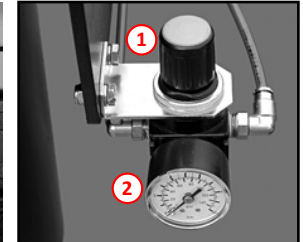

Mounted on subframe rear of suction tube

Overhead wander boom

These are mounted just above the wander boom handle and consists of two buttons for selecting 'BOOM BOOST' and/or 'LP WATER'.

'BOOM BOOST' selects the 3rd suction fan speed of approximately 2500 rpm. Auxiliary engine speed will automatically increase to 1800 rpm when 'boom boost' is selected.

'LP WATER' turns on additional low pressure water inside the overhead wander boom to help with dust suppression.

i Push button in to activate, button locks-in. Turn, direction of arrows, to release.



Overhead wander boom controls

Operating in sweep mode

Reducing noise levels and fuel consumption.

Although it is important to always operate within the engine's optimum speed range, there are times when it is possible to reduce engine speed to the lower end of this, thereby reducing noise levels. This is most beneficial when sweeping at night, or in areas sensitive to noise pollution. Sweeping at reduced engine speeds can be achieved most satisfactorily when sweeping light or sparsely distributed materials. Experience will enable the operator to vary engine speed, according to sweeping conditions, without affecting sweeping performance.

It should be noted that the operator also benefits from reduced noise levels within the cab and that any reduction in engine speed, also results in a corresponding reduction in fuel consumption.

Starting the auxiliary engine

When the sweeper's ignition is turned on the following events occur:

- The CANbus system checks that all control nodes are present and functioning correctly and the LCD Monitor turns on, briefly displaying the FAYAT logo (for approx. 10 seconds) before changing to display a basic truck graphic as well as the suction fan and auxiliary-engine speed scales.

If a system error is detected at this stage, the 'Fault Active' symbol will illuminate. 

To identify the error, refer to the Options Screen menus (Driver's Fault Codes) on page 45.

- The auxiliary engine's pre-heating cycle will commence.

To Start the auxiliary engine, proceed as follows:

1. Press and hold down the System Start/Stop switch  until the engine starts. When the engine starts, its default IDLE speed (1200 rpm) will register on the top right-hand section of the LCD monitor. With the engine running, the system is now effectively in Sweep Mode and a number of symbols representing the installed sweeping equipment will appear superimposed on the LCD monitor truck graphic.
2. On the control panels, select the desired sweeping equipment and activate the suction fan. Engine speed will automatically increase to one of two default settings as and when selected (overhead wander boom controls are external):





Operational modes and engine speed:

- Normal operation 1200 rpm
- Fan/High pressure pump operation 1600 rpm
- Fan boost 1700 rpm
- Overhead wander boom 1800 rpm

Sweeping

i If considered appropriate reduce engine speed to suit the prevailing sweeping conditions, by means of the engine speed controls  on the main panel. Auxiliary engine speed can only be adjusted between its minimum effective speed for the situation and the active preset default speed.



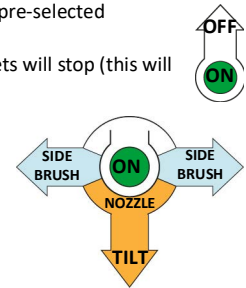

c Be aware that too much reduction of engine speed can adversely affect suction performance.

1. Switch on the hazard warning beacons.
2. Switch on suction fan  (approx. 2000 rpm) or Boost  (approx. 2200 rpm) as required.
The suction fan symbol on the LCD Monitor will change from GREY to GREEN  . Fan speed can be confirmed by referring to the LCD screen.
3. Select the desired configuration of brushes/suction boxes and water sprays (any combination of brushes and water can be selected) either manually or by pressing the Favourite Settings switch  to recall your preferred arrangement. Switch on work-lights as required.
4. Move the Multi-Function Switch (located on the auxiliary control panel) to the 'Sweep Master Switch ON' position to start and deploy the pre-selected sweeping equipment.
To stop and stow the sweep gear, return the switch to OFF. The sweeping equipment will raise to the stowed position and all water spray jets will stop (this will also occur automatically as soon as reverse is engaged, reverting to the original configuration as soon as reverse is disengaged).
5. Operate the multi-function switch to swing the side brushes OUT and the Nozzle Tilt switches (auxiliary control panel) as required to suit the sweeping conditions. The multi-function switch can also be used to control nozzle-tilt (Refer to page 19, for operating details).
6. Select on the vehicle the forward ratio best suited to the prevailing sweeping conditions and commence sweeping.







i While in the 'Sweep Master Switch ON' position, the multi-function switch will automatically return to the central position from the side brush and nozzle control positions.

Exiting sweep mode/stopping the auxiliary engine



1. Press the suction fan switch  to stop the fan. The suction fan symbol on the LCD monitor will change from GREEN to GREY  .
 2. Move the Multi-Function Switch (located on the lower extension of the auxiliary control panel) to the 'Sweep Master Switch OFF position. All active sweep systems will stop and retract.
- i** *If the Multi-Function Switch is not returned to the OFF position at this point, the sweeping equipment will not function upon any subsequent resumption of Sweep Mode until it has been first moved to the OFF position and then returned to the ON position.*
3. Allow the auxiliary engine to idle for approximately two minutes and then press the System Start/Stop switch . The engine will stop and the sweeping equipment symbols displayed on the LCD monitor truck graphic will extinguish, to show that Sweep Mode is OFF.



Engaging the reduction gearbox (scarab option only)

- i** *On vehicles fitted with a Scarab reduction gearbox, road speed of approximately 80% can be achieved when selected.*
1. Vehicle engine Running. Parking brake ON, Neutral gear selected. Auxiliary engine ON . Refer to page 18.
 2. Depress the clutch and press the **F1** switch on the main control panel. The  symbol on the LCD screen will change to the  symbol. The vehicle is now in reduction drive mode.
- i** *If the reduction gearbox fails to engage the  symbol will flash, Press the **F1** again to restore normal drive. Move the vehicle slightly forward and repeat the forgone procedure.*
3. Select the appropriate sweeping equipment. Refer to pages 18 and 19, and the best suited gear ratio for the prevailing sweeping conditions. Commence sweeping.

Disengaging the reduction gearbox (scarab option only)

1. With all sweeping equipment OFF and stowed, fan OFF. Vehicle Stopped. Parking brake On. Neutral selected.
 2. Auxiliary engine OFF (allow two minutes idling first).
 3. Depress the clutch and press **F1** on the main control panel. The  symbol On the LCD screen will change to the  symbol. The vehicle is now in normal drive mode.
- i** *If the reduction gearbox fails to engage the  symbol will flash, Press the **F1** again to restore normal drive. Move the vehicle slightly forward and repeat the forgone procedure.*









Discharging the hopper - tipping

-  **Ensure that all personnel are clear of the door.**
Ensure that the suction fan is turned off and that there is room for the door to open fully.
The door prop must always be used when working under a raised rear door.

 Before raising the hopper, ensure that the sweeper is on firm, level ground and there are no overhead obstructions.

 Before closing the door, ensure that the door seal, and mating faces on the hopper, are free from any foreign matter that might damage the seal or adversely affect the sealing function.

With the sweeper correctly positioned in the discharge area. Proceed as follows.

1. Vehicle engine OFF. Handbrake ON. Sweeper in Neutral. Multi-function lever OFF.
2. Auxiliary engine ON . Refer to page 18.
3. Open the rear door fully.  + 
4. Raise the hopper fully.  + 
5. With the load fully discharged, lower the hopper fully.  + 
6. Close the rear door  +  making sure the locking mechanism has fully engaged.
7. Move sweeper clear of discharge area.



Using the auxiliary hydraulic pump

 **Never work under a raised hopper or rear door unless the appropriate prop is in the deployed position.**

 *It should be noted that it will require a substantial number of pumping cycles to complete the following operations. The assistance of a second person is highly recommended.*

In the event of hydraulic system failure, an auxiliary (manually operated) hydraulic pump is fitted, to enable the rear door and hopper to be operated. This is located on the left hand side of the vehicle, adjacent to the hopper suction spigot. The pump handle is stowed in the cab.

1. Engine OFF. Handbrake ON.
2. Turn ON the ignition (do not start either engine).
3. Insert the pump handle. Pressing the required function button on the Remote Control and hold, while operating the pump handle.

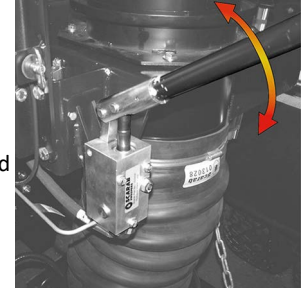









Standard wander hose

The wander hose is used to suck up objects in areas that the sweeper is unable to access i.e. drain inlets, under benches, etc.

Using the standard wander hose



Wear appropriate PPE.

1. Vehicle OFF. Neutral gear selected. Handbrake On. Sweep mode  and multi-function lever OFF.
2. Remove the wander hose  attached to the rear door.
3. Remove either of the blanking plate  from the rear door aperture and stow on the spare fasteners below.
4. Attach the wander hose over the exposed aperture , using the captive fasteners .
5. Sweep mode ON . Suction fan ON .
6. For situations requiring maximum suction power i.e. when removing stubborn objects, etc., select fan boost .
7. When finished, turn all controls OFF and return the wander hose to its stored position, replace the blanking plate.

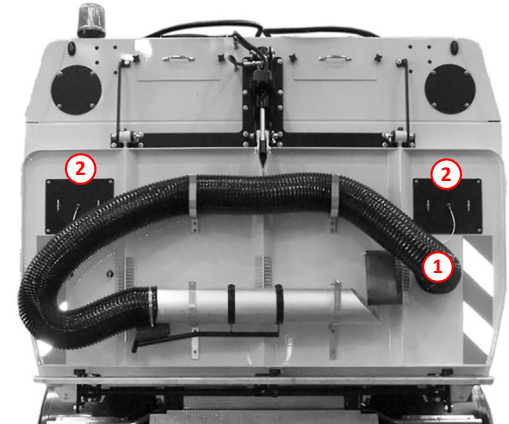
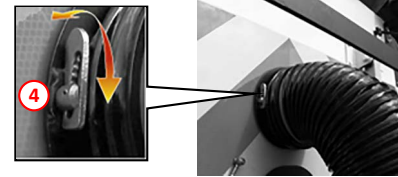



Rear mounted wander hose and overhead wander boom

Using the rear mounted wander hose



Wear appropriate PPE.

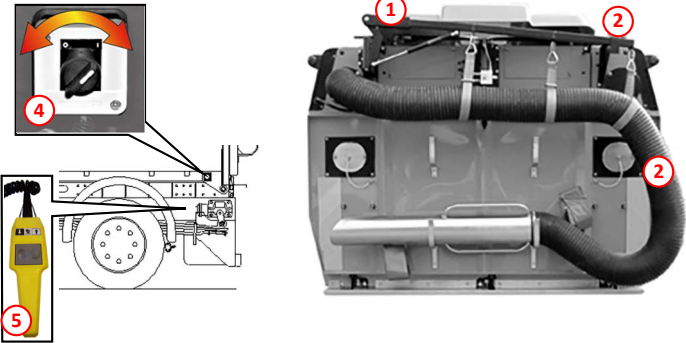

1. Vehicle OFF. Neutral gear selected. Handbrake On. Multi-function lever OFF.
2. Auxiliary engine ON, Suction Fan ON .
3. Unhook the wander hose boom ① from its stowed position w.
4. Demount the hose assembly e from its stowage and swing-out the entire assembly to the required position.
5. Turn the wander hose control ④ ON (always mounted on the drive side).
6. If water suppression is required place the multi function lever in the ON position.
7. On vehicles equipped with pneumatic assist, use the UP/Down controller ⑤ (always mounted on the drive side) to unhook the wander hose.
8. For maximum suction power, select fan boost .



Using the overhead wander boom



Wear appropriate PPE.

1. Vehicle OFF. Neutral gear selected. Handbrake On. Multi-function lever OFF.
2. Unlatch the hose assembly ⑥ from its stowage and attach suction tube ⑦ (extra tubes can be added to give greater length).
3. Unhook the overhead boom from its stowed position ⑧.
4. Sweep mode  and Suction Fan ON .
5. For greater suction use the fan boost .
6. If water suppression is required place the multi function lever in the ON position and use button ⑩ on the hose assembly control block ⑨.
7. An extra fan speed for the overhead boom can be selected, use button ⑪ on the hose assembly control block ⑨.

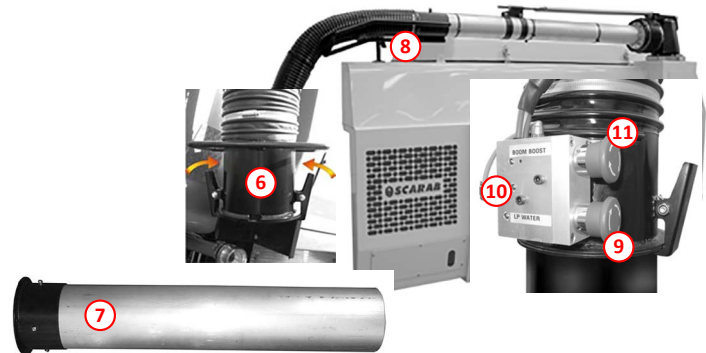

Dust suppression

Filling the water tank

Attach the appropriate coupling and water hose to the filler aperture ① and fill until the blue float reaches the top of the water level sight tube ② (use clean water).

Using the low pressure water system

The low pressure water is used on the, side brush(es), suction tube(s), and central (wide sweep) brush.

To operate any of these functions the relevant button(s) on the main panel must be selected when in sweep mode.

A shut-off valve is positioned between the pump and tank and must be open when the system is in use ③.

Each side brush is fitted with a shut off valve ④.

 It is vital that the water system is drained totally if the air temperature is expected to fall to 0°C or below.

Draining the system

1. Open tank drain valve ⑤.
2. Open drain valve at bottom of water filter ⑥, located on opposite side of the leg on which the low pressure water pump is mounted.
3. Open all brush shut-off valves ④.

 Due to customers requirements, other water features may be present but not mentioned in this publication.

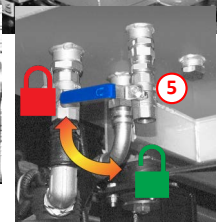
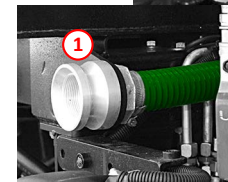
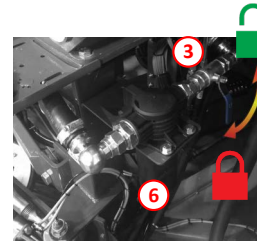
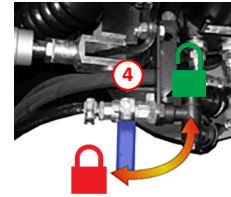

High pressure water system



High pressure water can be hazardous, always wear goggles or suitable eye/face protection.

Exercise extreme care when using the lance, do not direct the jet at other people or electrical connections.

Failure to comply can result in serious injury.



Wear appropriate PPE.

Using the high pressure water system

The high pressure water is used on the following options:-

- Front spray bar ①.
- Suction nozzle boost spray bar ②.
- Suction fan wash assist* ③.
- Hand lance and retractable hose* ④. See page 32.

To operate any of the above options the vehicle must be in hydrostatic drive, with sweep mode ON. Press the high pressure water switch on the auxiliary control panel and open the appropriate valve(s) for the function(s) required. Fan wash assist is only an aid to fan cleaning. It is recommended that this option is used immediately following a days sweeping. The fan should always be cleaned in accordance with the recommended operators routine maintenance.



Due to the possibility of excess water and loose material being ejected via the hopper hood when the suction fan is restarted, this procedure should only be carried out at an appropriate location.



**These options arenormally fitted on the drivers side.*

High pressure water shut off valves

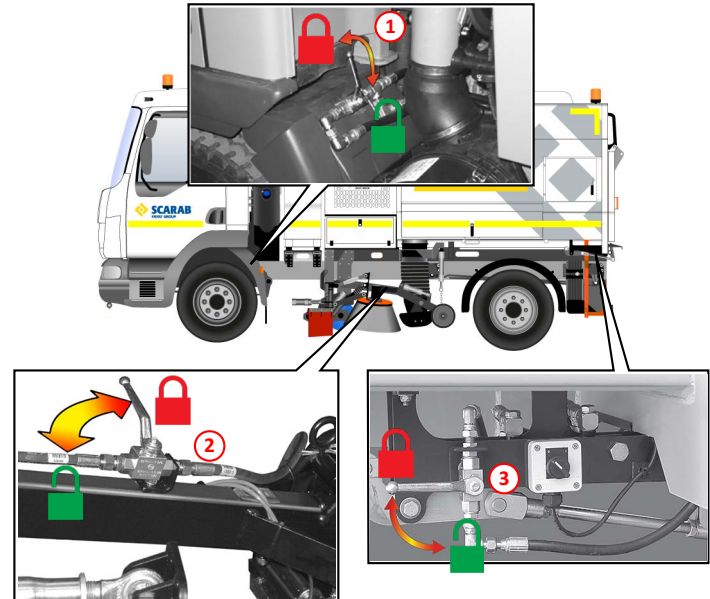

Hand lance detergent option



Wear appropriate PPE.

With the hand lance in use, check that the detergent container ⑤ has sufficient fluid. Turn on the control valve ⑥.

Adjust the spray pattern valve ⑦ on the hand lance to achieve desired affect.

Retractable hose

The hand lance ④ is attached to a 13 metre long rubber hose fitted to a hose reel i. When extending the hose, a ratchet mechanism allows the reel to lock in place. Further extending past the ratchet allows the reel to retract.

The position of the hose reel and hand lance is determined by the sweeper specification.

In certain cases the hand lance is fitted with a quick release coupling ⑨.

⚠ It is vital that the water system is drained totally if the air temperature is expected to fall to 0°C or below.

Draining the system

1. Open tank drain valve, see page 30.
2. Open drain valve at bottom of water strainer ⑩, open the shut valve ⑪.
3. Open pump drain valves ⑫ and ⑬.

⚠ The high pressure pump should never be allowed to run dry.

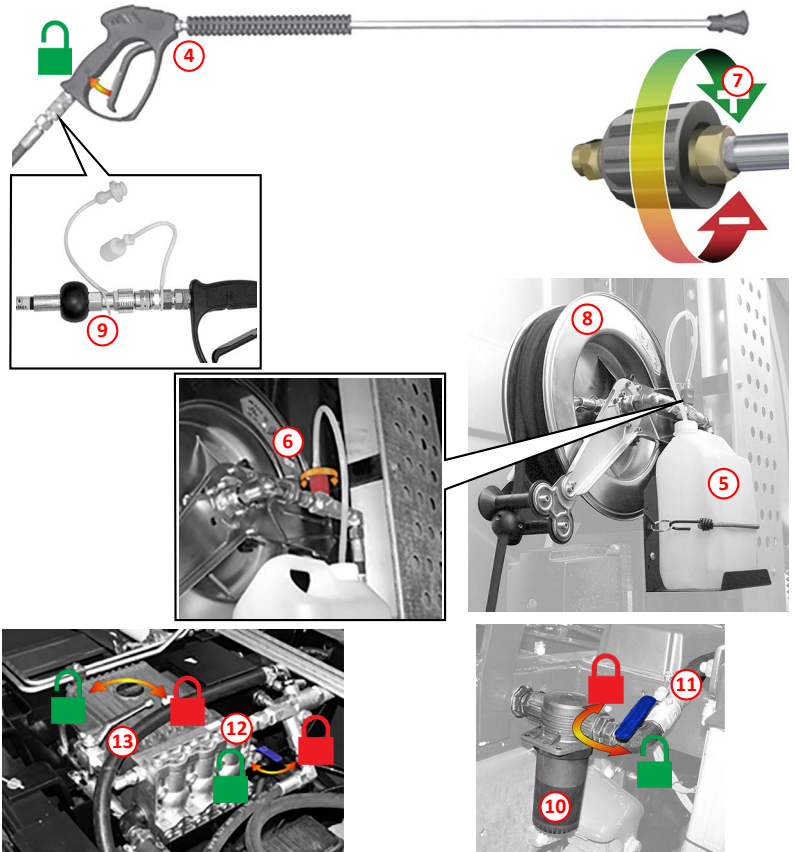

Clearing a blockage in the suction path



⚠ Never raise the hopper where the load it contains or the ground you are on could cause the vehicle to become unstable.

Ensure that the hopper prop is fully engaged when the hopper is in the raised position, see page 16. Failure to do so could result in serious injury.

Always be aware of the risk from sharp objects and never place your hands into the blockage, even when wearing gloves. Exercise extreme caution when handling any items removed from the suction system, keeping such activities to the absolute minimum.

A blockage in the suction path will be indicated by a trail of material behind the vehicle.

Use the following instruction to locate and remove the obstruction:-

1. With all sweep equipment retracted and stowed.
2. Raise the hopper , which deploys the safety prop. Stop engine. Remove ignition key.
3. Visually check the suction path to determine the nature and location of the blockage. If no blockage is present, further investigation of the suction system will need to be carried out.
4. If the blockage is still present, use a suitable implement (a stout length of wood is ideal), to remove the obstacle by pushing it downwards.
5. Lower the hopper , but do not start the suction fan at this stage.
6. Move the vehicle sufficiently to expose the cause of the blockage. Stop the vehicle, apply the parking brake and remove the ignition key. Carefully isolate the blockage and if appropriate, place it in the hopper via the side loading hatch.
7. Resume sweep mode. Lower the suction box and switch on the fan. Assure the suction is correctly functioning.
8. Return to the start of the trail created by the blockage and continue sweeping.

    Wear appropriate PPE.

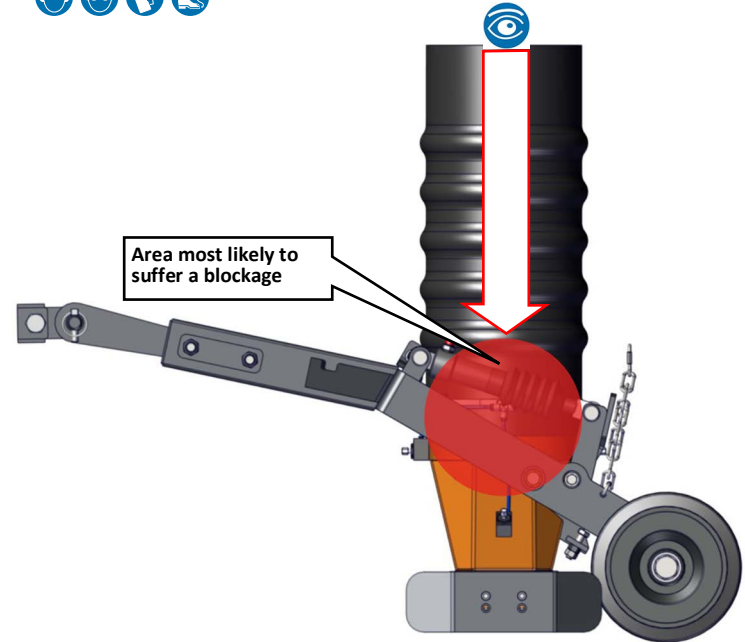

Operator's routine maintenance

It is important that the following routine maintenance procedures are carried out as directed. This will help to ensure that your Scarab sweeper performs at the optimum level of safety and efficiency. Refer to the paragraphs immediately following this schedule and to the Table of Contents for more detailed information.



Wear appropriate PPE.

Maintenance Procedure - Daily Actions Before Use	
1	Check vehicle/body for safety. All lighting equipment, tyres, fuel, oil, coolant, brake fluid, windscreen wash and water tank level.
2	Check auxiliary engine, fuel, oil and coolant levels
3	Check hydraulic oil level and inspect system for signs of leaks. Check oil cooler is clean.
4	If the vehicle was not previously used by YOU , check suction fan is clean.
5	Check brushes/skirts for wear or damage. Remove entangled items, e.g. string and strapping. etc.
6	Check suction nozzle flaps for damage/correct ground clearance.
7	Check water spray jets for blockages.
8	Check that all equipment is securely stowed and brushes are retracted.

Maintenance Procedure - Daily Actions After Use	
9	Wash vehicle, particularly hopper screen, surrounding ledges and area above. Leave hopper door partially open, to allow air to circulate.
10	Wash oil cooler, ensuring that the fins are clean.
11	Lubricate as appropriate, all brush links, pivot.
12	Remove/clean the water filter elements.

Maintenance Procedure - Weekly	
13	Clean the suction fan thoroughly, using the scraper provided and high pressure water. <i>See page 36.</i>
14	Grease hopper ram (Top and bottom).
15	Visually check entire machine for wear/damage.
16	Check wiring and hoses for security of attachment and signs of wear and/or damage.
17	Check wear in suction tubes and deflectors in hopper.
18	Check seals on hopper door, side hatches and suction tubes.
19	Check oil level in high pressure water pump, top up if needed.
20	Grease all points. <i>See page 43.</i>

Other Maintenance Procedures	
21	Lithium grease the low pressure pump every 50 hours of the pump running and/or every service. 10 grams or 0.4oz (10 pumps)

 **It is vital that the water system is drained totally if the air temperature is expected to fall to 0°C or below.**

 *In frosty weather leave the hopper slightly raised with the rear and side door partially open.*

 *The foregoing are general recommendations only. Requirements vary from territory to territory and depend on vehicle usage/operating conditions. **If in doubt consult your nearest dealer.***





Key maintenance procedures

 Wear appropriate PPE.

Cleaning the suction fan and screen

-  **Failure to comply with the following could result in serious injury. Before working on the sweeper position it on firm, level ground and apply handbrake. The fan is an extremely heavy rotating mass. never attempt to slow or stop its rotation by using the hands or by inserting any item into the fan chamber, even at low speeds. Never work under a raised rear door unless the prop is in the deployed position. See page 16.**

 Loose particles from the cleaning process can be ejected via the hopper cover when the fan is restarted, ensure that all personnel are clear before restarting.

1. Turn engine OFF. Remove Ignition key.
2. Use a suitable platform to enabling you to reach the area above the rear door.
3. With the fan stationary, remove the outer and inner inspection covers from the hopper to expose the fan.
4. Using the special scraper, thoroughly clean all parts of the fan. A steam-cleaner or high-pressure water from a remote source will greatly assist in cleaning severely contaminated fans.
5. Refit the inspection covers and open the rear door .
6. Lower the screen. Wash the screen using steam or high-pressure water.
7. Raise the screen and close the rear door .
8. Start the engine  and switch the suction fan ON .
9. With the rear door shut, direct additional water onto the screen below the fan inlet cone, from an open side access door, until only clean water is expelled from the fan casing.

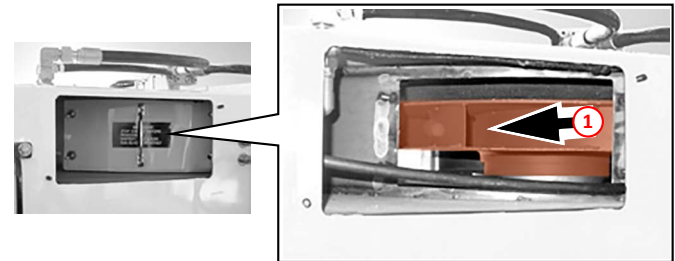

 Please pay particular attention to the inner curve of the fan blade and also the centre of the unit where dirt accumulates around the hub, ①.

Auxiliary engine



Wear appropriate PPE.

- ⚠** Ensure that the hopper safety prop has deployed correctly when working beneath a raised hopper. Failure to do so could result in serious injury. When mounting the chassis always use the access steps and tread plates. Ensure they are free from contamination that may cause them to become slippery. Always wear suitable footwear with clean and dry soles.
- ⚠** Ensure that the sweeper is on a flat and level surface with the auxiliary engine stopped for a suitable period, to allow the oil to return to the sump.
- i** The auxiliary engine is the responsibility of the operator, as is the chassis engine. The following instructions should be followed as detailed in the maintenance schedule on page 34 and in the manufacturer's recommendations.

Raise the hopper in accordance with the instructions detailed on page 20.

Engine oil

- i** Engine oil: (15w/40).
Allow time for the added oil to drain through to the sump before re-checking the level.

Topping up

1. Remove the dipstick ① from the holder.
2. Wipe clean with a lint-free cloth.
3. Replace in its holder. Remove again and check the oil level.
4. The oil should never fall below the minimum level or exceed the maximum level shown on the dipstick.
5. Remove the filler cap ② and pour oil through the opening until the correct level is maintained.
6. Replace filler cap.

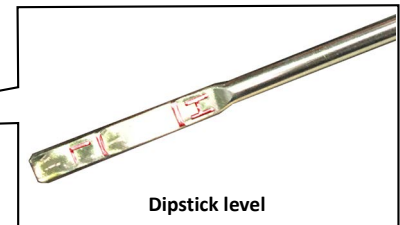
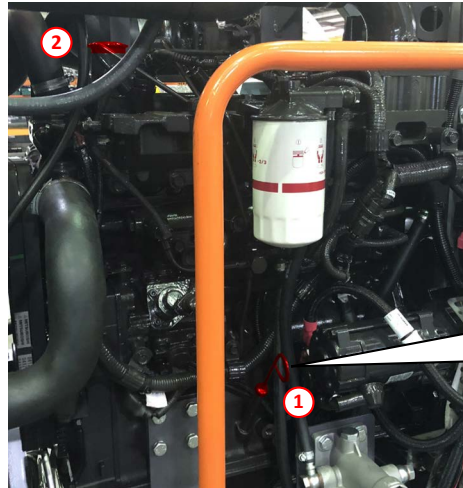

Engine coolant



Wear appropriate PPE.

- ⚠** Ensure that the hopper safety prop has deployed correctly when working beneath a raised hopper. Failure to do so could result in serious injury. When mounting the chassis always use the access steps and tread plates. Ensure they are free from contamination that may cause them to become slippery. Always wear suitable footwear with clean and dry soles. If topping-up is required when the coolant is hot adequate precautions must be taken, as an overpressure will have built up in the system.

- ⚠** Ensure that the sweeper is on a flat and level surface with the auxiliary engine stopped for a suitable period, to allow the oil to return to the sump.

- i** Coolant: Ethylene Glycol (Eskimo long life).
It is advisable to top-up the coolant level when the engine is cold.

Raise the hopper in accordance with the instructions detailed on page 20.

Topping-up

1. Remove the filler cap from the coolant expansion tank **①**.
2. Run the engine for several minutes.
3. Stop engine and check coolant level.
4. Top-up to the appropriate level, using the correct coolant mixture.
5. Replace the filler cap **①**.



Hydraulic oil tank



Wear appropriate PPE.

- ⚠** Ensure that the hopper safety prop has deployed correctly when working beneath a raised hopper. Failure to do so could result in serious injury. When mounting the chassis always use the access steps and tread plates. Ensure they are free from contamination that may cause them to become slippery. Always wear suitable footwear with clean and dry soles.

- ⚠** Ensure that the sweeper is on a flat and level surface with the auxiliary engine stopped for a suitable period, to allow the oil to cool.

- i** Hydraulic oil: HLP32 or equivalent. Fuchs Renolin B10 VG 32 (as used by Scarab Sweepers). It is advisable to top-up the Hydraulic oil level when the system is cold. The hopper must be in a fully lowered position for checking the hydraulic oil level and when topping up.

Topping-up

1. Open the right hand engine gantry door to gain access to the hydraulic tank.
2. Using the appropriate size spanner, remove the filler cap ①.
3. Top-up with HPL 32 or an equivalent hydraulic oil to the appropriate level.
4. Remember the hopper has to be down to check the hydraulic oil level.
5. Replace the filler cap ①.

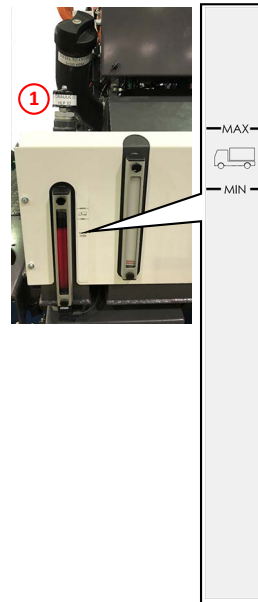

Oil tank components

- ① - Fill/breather cap.
- ② - Return filter.
- ③ - Sight glass.
- ④ - Suction filter.

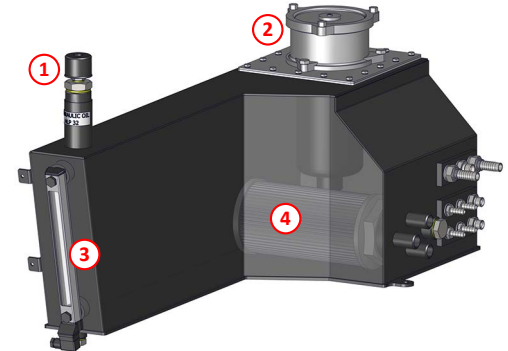

Suction nozzle clearances



Wear appropriate PPE.

Inspect the suction nozzle flaps to verify that they are in good condition and do not show excessive wear. Adjust as necessary to achieve the correct flap to ground clearances.

The factory settings are:

- Inboard Side Flap = 15 mm
- Front Flap = 20 mm
- Rear Flap = 15 mm

i *These clearances are based on the factory set-up. For some operating conditions, it might be found that, alternative clearances are preferred.*

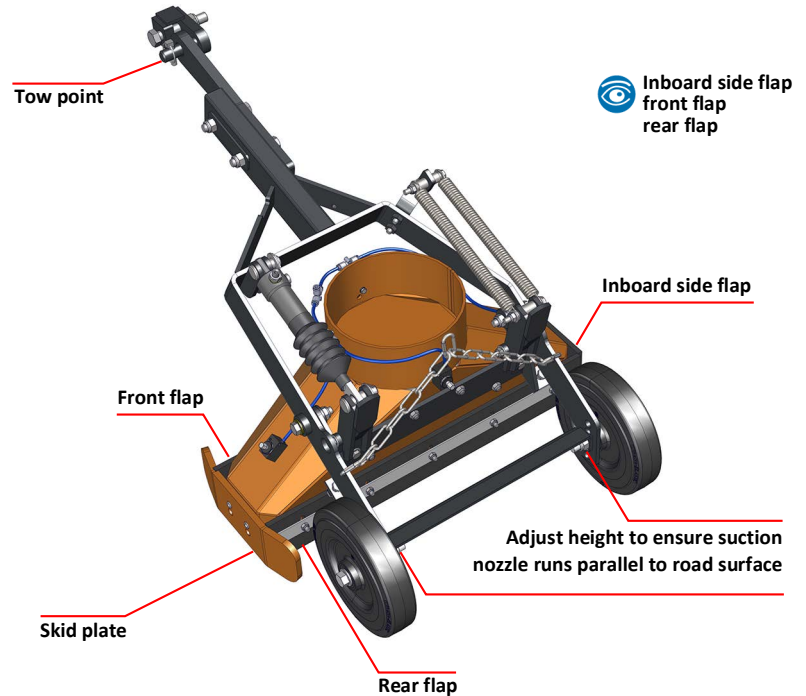

Side brushes





Wear appropriate PPE.

⚠ Do not attempt to alter the brush settings or side skirts while the brush is rotating.

⚠ Before proceeding ensure people and objects are clear of the brush area.

An effective brush set-up ensures good sweeping performance. The following settings produce excellent results in most conditions. Experience will determine if other settings are better suited to specific conditions.

1. Vehicle stopped, handbrake ON, sweep mode ON **Ⓢ**, activate the desired brush(es)   in their working positions.
2. Switch OFF ignition and remove the key.
3. Locate the appropriate valve(s) in the pneumatic cabinet and activate the manual override to allow the brush(es) to extend.
4. Adjust the top link **①** and/or the motor plate **②** until the brush is at the correct contact with the road surface. Re-tighten any items slackened during adjustment.
5. Re-start vehicle, stow all sweeping equipment activated for adjustment.

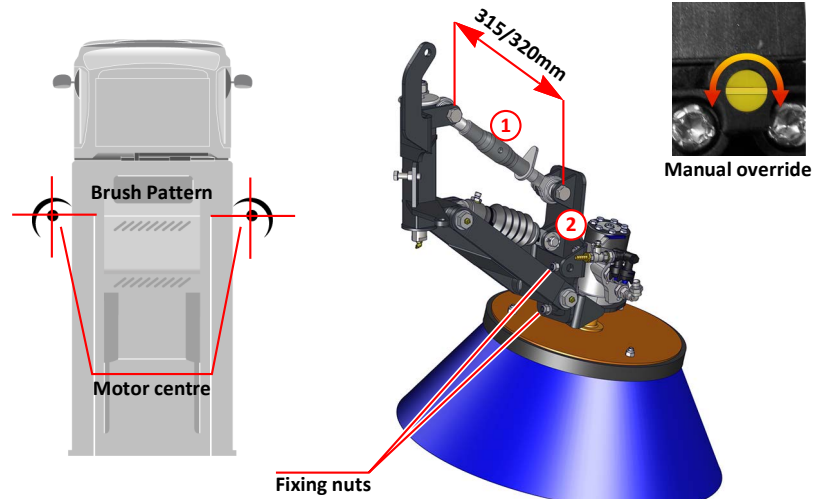

Side skirts

The side skirts that are adjacent to the side brushes need to be adjusted so that they are just clear of the ground when they brushes are in the deployed position

It maybe necessary to trim the lower edge of the skirt with a sharp knife and straight edge for it to be parallel to the ground.

To adjust the side skirts loosen the nuts on the clamp that hold the side skirts in place then...

1. If the skirts are slotted then slide the skirt on the slots to achieve desired height from the ground.
2. If the side skirt has holes then you will need to remove the nuts and the clamp holding them in place and move the skirt to another set of holes, then re-attach the skirt clamp and nuts.

Tighten any loosened nuts.

Removing and cleaning the water filter element(s)



Wear appropriate PPE.

Both the low-pressure and, if fitted, the high-pressure water pump are have strainers to ensure that foreign matter does not enter the pump. The following steps detail the recommended cleaning procedure.

1. Close shut off valve ①.
2. Open drain valve ②.
3. Unscrew the filter bowl ③ clockwise from the housing ④ and remove the element ⑤.
4. Wash out the element ⑤ with clean water or replace if too contaminated.
5. Before re-assembling the unit, apply some grease to the O-seal ⑥ to ensure a water-tight fit for the filter bowl.
6. Refit the element and filter bowl ③.
7. Close the drain valve ②.
8. Open the shut of valve ①.

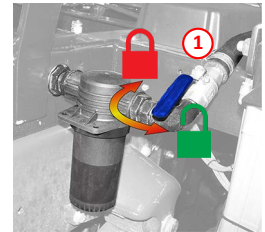
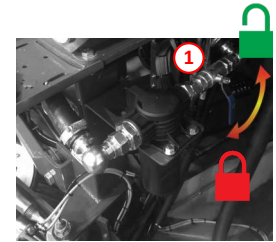
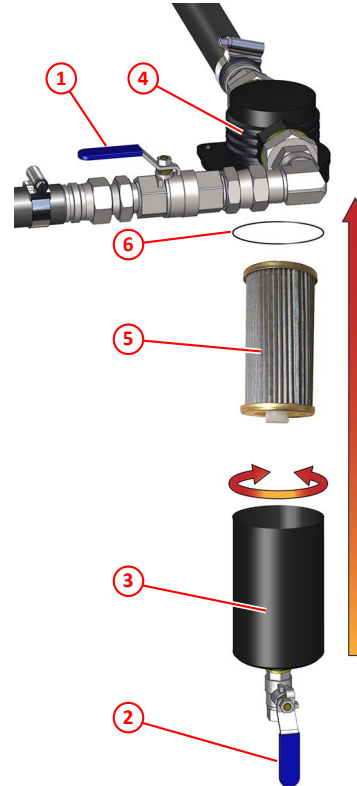

Manual greasing and lubrication

Carry out manual greasing in accordance with the appropriate schedule on page 34 and by referring to the accompanying diagrams shown here.

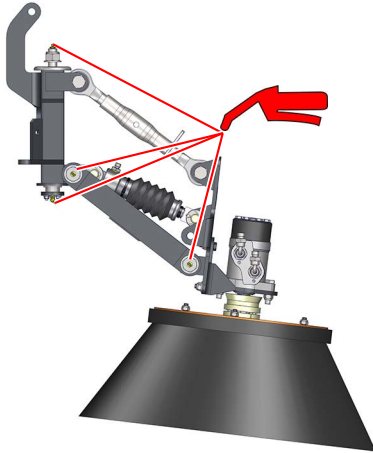

Side brush assemblies

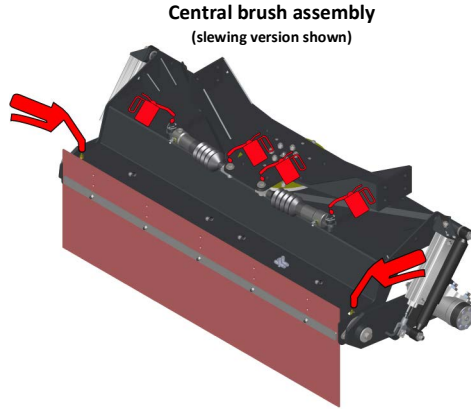

Central brush assembly
(slewing version shown)

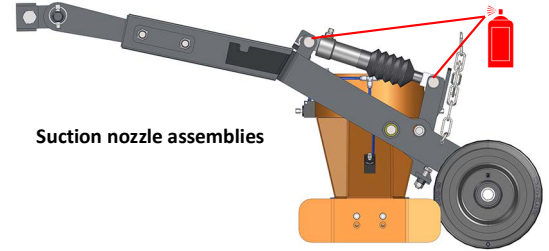

Suction nozzle assemblies

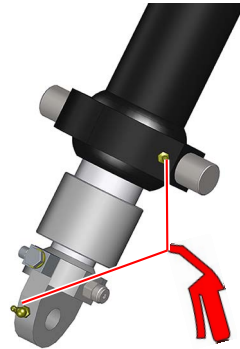

Hopper ram

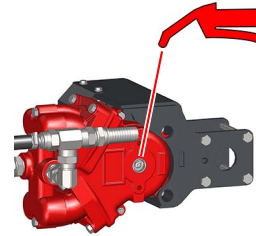

Low pressure
water pump

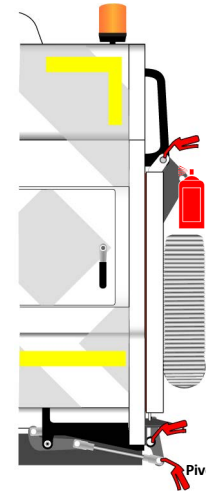

Door hinge x3

Hopper rear door ram

Locking clamp x3

Pivot rod x2

LCD monitor - Options screen





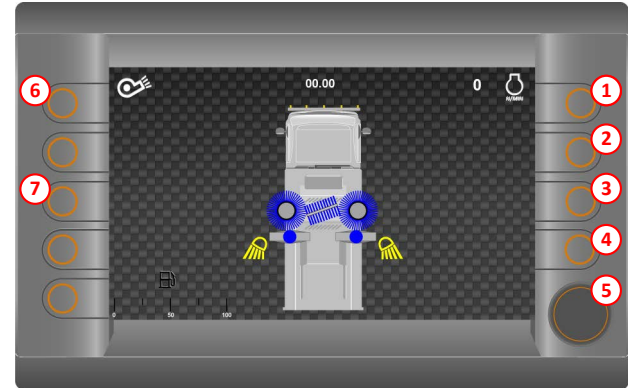

To access the option screen mode from the start up screen press button ②.

Button function

- ① - **Display:** Press to change background colours (black/white).
- ② - **Options:** Press to access option screen mode (illustrated).
- ③ - **Hours:** Press to view hours logged.
- ④ - **Return:** Press to return to previous screen.
- ⑤ - **Encoder:** Turn to highlight required option, press to enter. Used in all screen modes.
Press to display side tabs from the sweeping mode screen.
- ⑥ - **Camera:** Press to enable in forward drive. (rear view only)
- ⑦ - **Warning buzzer:** Press to disable the hopper raise/lower and rear door open/close warning buzzer.



Option screen menu description

-  Driver's fault codes
-  EDC
-  Screen settings
-  Information
-  Button check
-  CAN menu (Password protected)

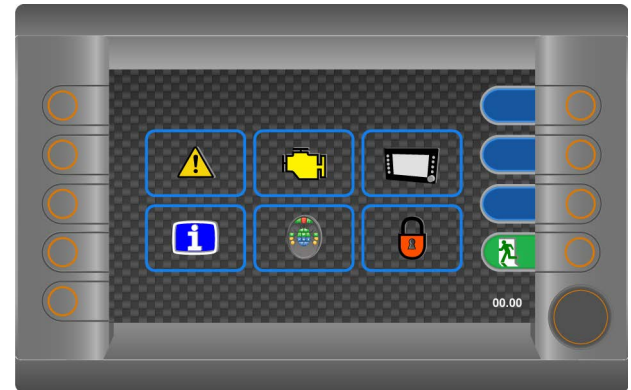

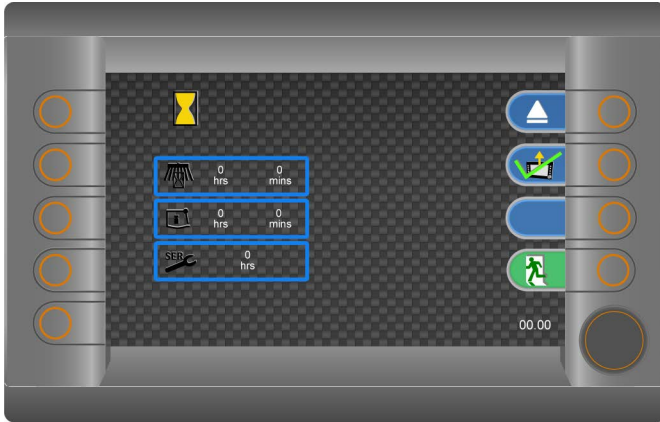

Hours worked

Displays the working time of various functions.
Service Hours only display when activated.

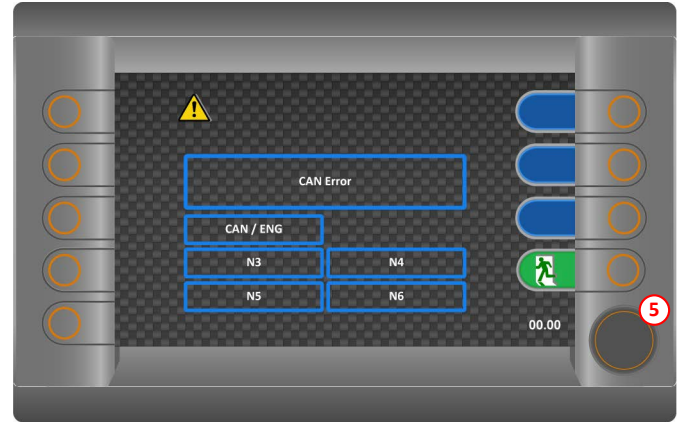

Driver fault codes

Highlight either the CAN or desired Node using the encoder ⏪.
Press the encoder ⏩ to enter.

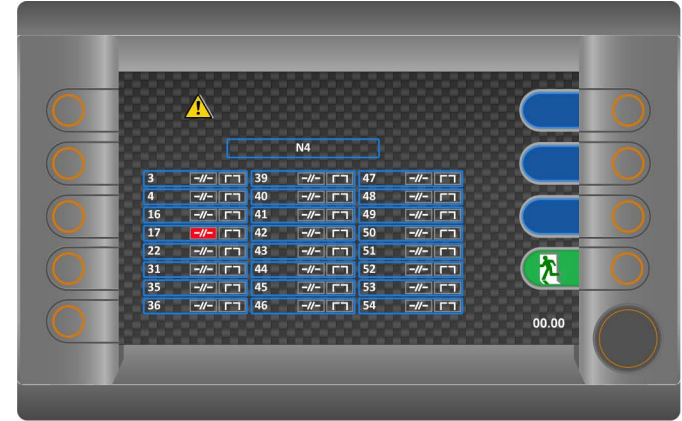
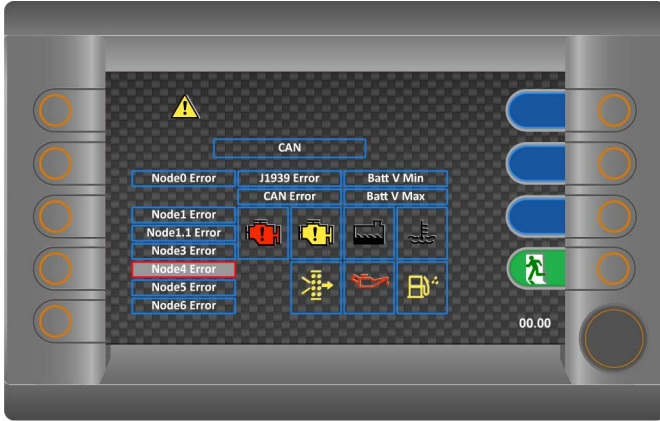

CAN error screen

Identifies location of system errors.
Highlighted in red when active.

Driver fault codes

Entering a Node screen allows Pin-Contact view.
Pin numbers with an active fault are highlighted in RED.

- // = Open Circuit.
- = Short.

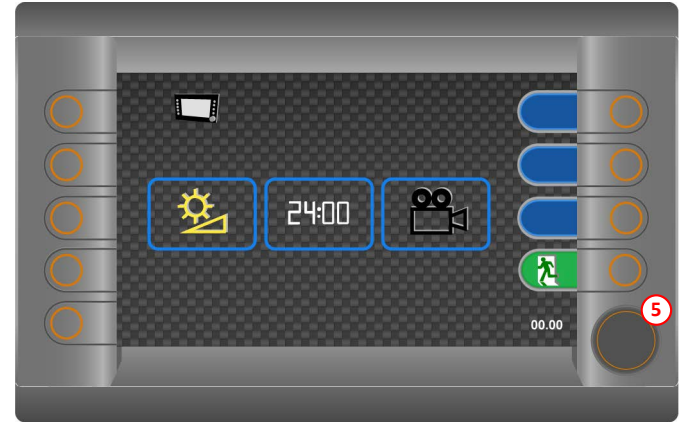
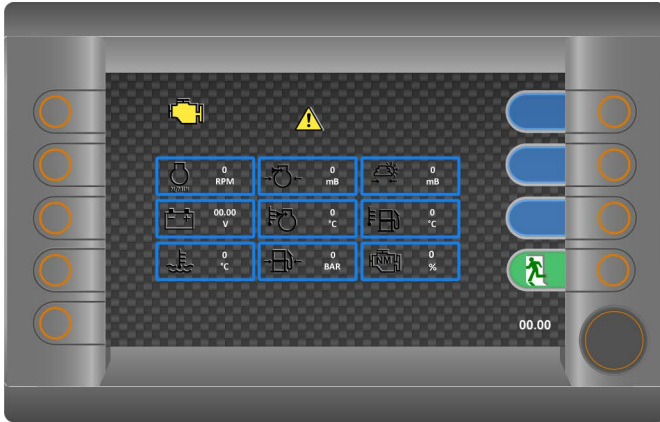



EDC

Displays the following current conditions:

- Engine Speed
- Battery Voltage
- Coolant Temperature
- Turbo Boost Pressure
- Turbo Air Pressure
- Fuel Pressure
- Barometric Pressure
- Fuel Temperature
- Engine Load

Screen settings

Highlight the desired panel using the encoder  and press the encoder  to enter the selected setting screen.

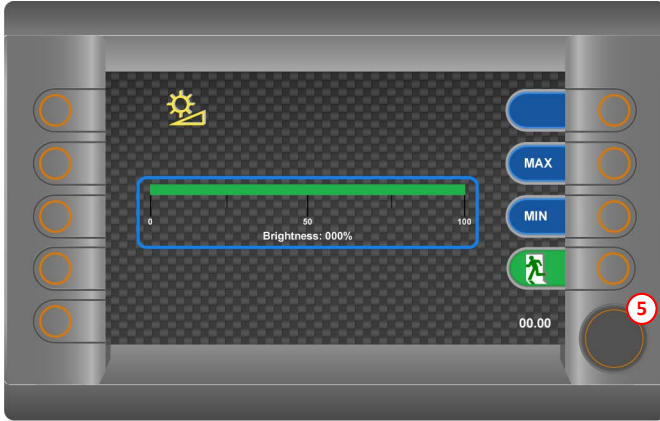

Screen brightness setting

Rotate the encoder ⑤ to adjust the screen brightness (2% increments).
Pressing the MIN button adjusts the brightness to 10%.
Pressing the MAX button adjusts the brightness to 100%.

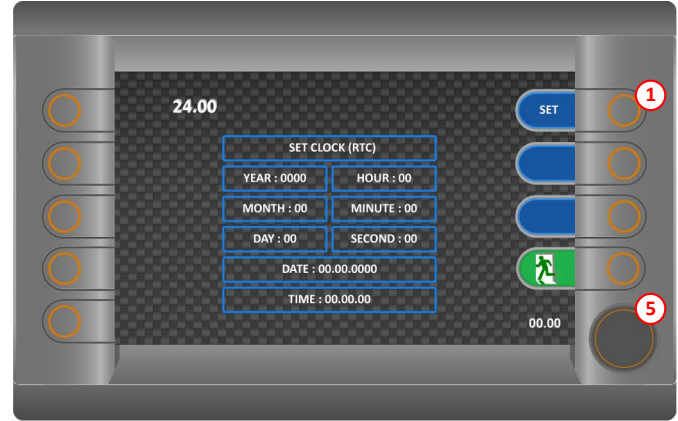

Time and date setting

Rotate the encoder ⑤ to the desired panel and then press the encoder ⑤ to select.
Rotate the encoder ⑤ to the correct, Year, Month, Day, Hour, etc.
when it is the correct value press the SET button ①.
Repeat above steps as required.

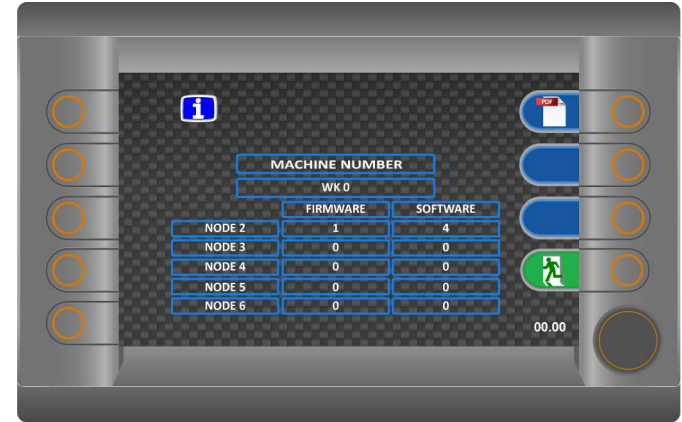

Rear camera

Enable/disable rear camera.

Rotate the encoder ⑤ to select the on/off button then press the encoder ⑤ to toggle on/off.

A green tick displays in the centre of screen icon when camera is activated.

i This function allows rear viewing when the vehicle is in forward drive. When reversing rear viewing will activate automatically and be displayed.

Information

Displays the machine number and current Node program version. Press button ① to access the PDF viewing screen. Follow the on screen directions.

⚠ Only to be used when vehicle is stationary and auxiliary engine is off.

i On exiting PDF viewer, ignition must be turned off and back on again.

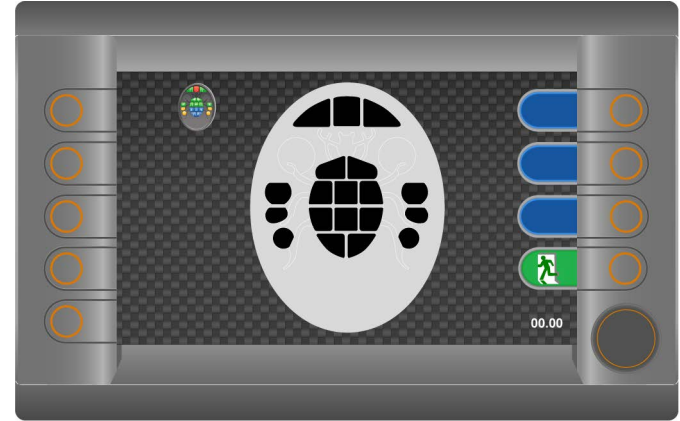

Button check menu

Use the encoder ⑤ to highlight the appropriate panel and then press the encoder ⑤ to select.

Main control panel button check

Press the appropriate button on the main control panel. As each button is pressed the corresponding graphic will illuminate green. A beep will sound if the function is fitted.

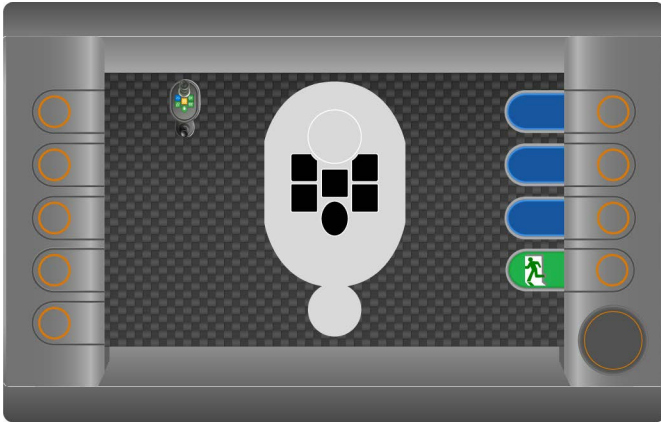

Auxiliary control panel button checks

Press the appropriate button on the auxiliary control panel.
As each button is pressed the corresponding graphic will illuminate.
A beep will sound if the function is fitted.

Scarab Sweepers Limited
Pattenden Lane, Marden, Kent TN12 9QD

Telephone: 01622 831 006
International: +44 (0) 1622 831 006
e-mail: scarab@scarab-sweepers.com

Fax: 01622 832 417
International +44 (0) 1622 832 417
Web site: www.scarab-sweepers.com