



SCARAB
FAYAT GROUP



MINOR ROAD SWEEPER

ILLUSTRATED PARTS CATALOGUE

ILLUSTRATED PARTS CATALOGUE

Minor with CAN bus 3 Control System

Manual SCAZ039375

Version: 2.6.27 3rd April 2024

To download the latest version visit our website

Important Notice To Users

This manual is published by the Technical Publications Department of Scarab Sweepers Limited and every effort is made to ensure that the information it contains is correct at the time of publication. Due to a policy of continuous development, however, the Company reserves the right to alter the specification and to supply when so altered without reference to illustrations and descriptions in this manual.

Parts depicted or mentioned in this manual may or may not be fitted to your particular road sweeper due to various options that may or may not have been selected and does not therefore infer that the part should be fitted to your particular road sweeper or is missing. If in doubt then please contact the Scarab Parts Department for clarification.

It is imperative that the correct model is fully identified when procuring replacement parts for your Scarab Sweeper. To avoid unnecessary confusion and delays caused by incorrectly ordered parts, please refer to the Vehicle Serial Number (CE) Plate and take note of the vehicle's number.

i The Serial Number Plate is located on the rear of the cab low down on the right hand side of the vehicle.

The example shown here is for guidance only.



	Scarab Road Surface Cleaner www.scarab-sweepers.com		Scarab Sweepers Limited Pattenden Lane, Marden, Tonbridge, Kent. TN12 9QD, England.	
	Type	<input type="text"/>		
	Serial Number	<input type="text"/>	<input type="text"/>	
Year of Manufacture	<input type="text"/>	<input type="text"/>		

This information must accompany every parts order to help ensure that the correct parts are supplied.

How To Use This Illustrated Parts Catalogue

Introduction

This Illustrated Parts Catalogue has been organised to facilitate ease of use when identifying and procuring replacement parts for the Scarab Sweeper.

The information content has been arranged in a logical manner by creating a number of separate sections, each dealing with a specific aspect or sub-system of the machine, complete with its own table of contents. Where relevant, cross-references from one section to another have been included to enable the user to quickly navigate to the information that gives the required level of detail.

Using the Parts Lists

The breakdown structure within each parts list reflects the inter-relationship of the various components in an assembly. The order of information (L to R) is: Item/Part No./Quantity/Description.

The first item on a parts list, is the description of the main assembly in question, is shown in bold, thus:

Description of Main Assembly

The succeeding parts generally fall into two categories, namely attaching parts i.e. bolts, screws, nuts, washers etc. or breakdown parts i.e. assemblies/sub assemblies and/or piece parts.

Item Numbers

Item numbers are used to cross-refer items from the parts lists to their associated illustrations and vice-versa, except for, attaching parts.

If the illustration of an item is superfluous, then the item number will be listed as not illustrated:- **NI**.

Part Numbers

Not every item will have a part number associated with it because it might be an assembly that is broken down into its components elsewhere or there might be different versions of that item described elsewhere.

Quantities

When a parts quantity has been marked with **AR** then this means **as required**, for example hose lengths may differ slightly due to the route taken, or you may have one or more of a given part then the quantity will be **as required** due to the quantity of said part that is fitted to a particular sweeper configuration.

PDF Version

The PDF version of this manual has been created to open like you would the real manual with two pages per view, so do not click the one page per view button otherwise it makes it harder to read. It will include bookmarks to each chapter and links to other sections from components that are also referenced elsewhere to make navigation throughout the manual easier.

Warranty Statement

1. Scarab Sweepers Limited (hereinafter referred to as the Company) warrants that (subject to the other provisions of the published Terms and Conditions of Sale - available upon request) upon delivery and for a period of 12 months from the date of actual delivery, or 2,000 running hours from the date of actual delivery whichever is sooner, the Goods correspond with their specification at the time of delivery, and will be free from defects in materials and workmanship.
 2. The Company does not warrant the condition or quality of any used Goods supplied to the Customer, or to the engine fitted in the Scarab Minor Sweeper or to any other component not manufactured by the Company and any such warranty claims must be submitted to the manufacturer of that component, or their locally appointed agent.
 3. The Company shall not be liable for a breach of any of the warranties in condition 1 unless the Customer gives written notice of the defect to the Company, and (if the defect is as a result of damage in transit) to the carrier, within 7 days of the time when the Customer discovers or ought to have discovered the defect.
 4. The Company shall not be liable for a breach of any of the warranties in condition 1 if the Customer makes any further use of such Goods after giving such notice, the defect arises because the Customer failed to follow the Company's oral or written instructions as to the storage, installation, commissioning, use or maintenance of the Goods or (if there are none) good trade practice, or the Customer alters or repairs such Goods without the written consent of the Company, or uses non genuine parts to effect a repair.
 5. The following consumable items listed are excluded from the Company warranty:
 - all fuel oils,
 - antifreeze,
 - all brush link pivots and bushes,
 - wander hoses, suction nozzles,
 - body inlet ducts, wearing plates,
 - high pressure water pump piston seals and valves,
 - door seals,
 - inlet seals,
 - batteries,
 - tyres,
 - all brushes,
 - lift cables,
 - rubber skirts,
 - suction nozzle wheels,
 - flap trunking,
 - deflectors,
 - screens flaps or blanking plates,
 - water pump diaphragm valves and water jets,
 - all filter strainers and elements,
 - windows,
 - glass mirrors,
 - light bulbs,
 - fuses,
 - brake lining pads,
 - auxiliary drive belts and any other part normally regarded as consumable.
 6. Any parts replaced under the terms of this warranty will be covered by the unexpired portion of this warranty.
 7. Subject to conditions 3 and 4, if any of the Goods do not conform with any of the warranties in condition 1 the Company shall at its option repair or replace such Goods (or the defective part) or refund the price of such Goods at the pro rata Contract rate provided that, if the Company so requests, the Customer shall, at the Customer's expense, remove the defective Goods or part of such Goods and return the Goods or the part of such Goods which is defective to the Company. Parts replaced under warranty will be delivered by the Company FOB port of exportation.
 8. If the Company complies with the terms contained in this statement it shall have no further liability for a breach of any of the warranties in condition 1 in respect of such Goods.
 9. No representative or agent of Scarab Sweepers Limited has the authority to add or to vary these Warranty Conditions except with the Company's official confirmation in writing from Scarab Sweepers Limited, head office in Marden Kent, England.
- For further information, please refer to the Company's Terms & Conditions of Sale. In the event of conflict between this Warranty Statement and the Company's Terms & Conditions of Sale the latter will prevail.

Table Of Contents

<i>Description</i>	<i>Page</i>
Engine System	11
Engine	12
Engine Sensors	12
Engine Belt Covers	14
Cooler and Intercooler	16
General Arrangement	16
Exhaust, Cooling and Intercooler	18
General Arrangement	18
Air Cleaner Components	20
Fuel System	22
Drive line	25
Drive line - General Arrangement	26
Drive Motor Assembly	28
Prop Shaft General Arrangement	30
Rear Axle Assembly	32
FPW Drive Axle Assembly	34
FPW Drive Axle, Axle Components	36
FPW Drive Axle, Gearbox Components	38
Chassis	41
Chassis General Arrangement	42
Chassis General Arrangement	44
Chassis General Arrangement	46
Rear Lights, Bumper and Brackets (April 2013 - on)	48
Bumper Conversion (April 2013 - on)	48
Gantry General Arrangement	50
Gantry General Arrangement	52
Front Mud Flap Assembly	54
Rear Mudguard Assembly	54
Front Suspension Assembly	56
Rear Suspension Assembly	58
Front Axle Steering/Hub Arrangement	60
LHD from June 2011, RHD from August 2013	60
Steering Arrangement	62
LHD from June 2011, RHD from August 2013	62
Front Axle Steering/Hub Arrangement	64
LHD Pre June 2011, RHD Pre August 2013	64
Front Axle Steering/Hub Arrangement	66
LHD Pre June 2011, RHD Pre August 2013	66
Steering Arrangement	68
LHD Pre June 2011, RHD Pre August 2013	68
Teal Hand Wash Basin Assembly	70
Brakes and Related Equipment	73
Braking System - General Arrangement	74
Brake Pedal Assembly	74
Front Brake Caliper	76
Rear Brake Arrangement	76
Hand Brake Assembly	78
Cab Components	81
Cab External Components and Associated Parts	82
Cab External Components and Associated Parts	84
Cab Interior and Associated Parts	86
Cab Interior and Associated Parts	88

Cab Interior and Associated Parts	90
Steering Column Assembly	92
Cab Safety Latch Assembly	94
Cab Locking Assembly	94
Hydraulically Assisted Cab Tilt	96
Hydraulically Assisted Cab Tilt - Circuit Components	98
Cab Heater and Optional Air Conditioning Arrangement	100
Air Conditioning Compressor Arrangement	100
Air Conditioning Condenser/Radiator Arrangement	102
Sweeping and Suction System	105
Wide Sweep Arrangement - Left Hand Single Sweep Machines	106
Wide Sweep Arrangement - Right Hand Single Sweep Machines	108
Wide Sweep Arrangement - Dual Sweep Machines	110
Wide Sweep Lifting Arrangement	112
Front Brush Arrangement	114
Front Brush Swing Out and Fixed Arrangement	116
Side Brush Arrangement	118
Side Brush Swing Out Arrangement	120
Suction Nozzle Arrangement	122
Suction Nozzle Lifting Arrangement	124
Standard Wander Hose Assembly	124
Overhead Boom Arrangement	126
Hopper and Related Equipment	129
Hopper - General Arrangement	130
Hopper Rear - General Arrangement	132
Rear Door - General Arrangement	134
Internal Hopper Components	136
Suction Fan Assembly	136
Auto Blanking Main Assembly	138
Standard Wander Hose Assembly	140
Wander Hose Manual Blanking Assembly	140
Overhead Boom Arrangement	142
Hi-Tip Hopper and Associated Components	144
Hydraulically Operated Rear Door Arrangement	146
Washing and Dust Suppression	149
Water Tank Arrangement	150
Hydrant Filler Kit and Mounting Items	152
Low Pressure Water Pump Assembly	154
Water Valve Arrangement	154
Low Pressure Water Filter Assembly	156
6 Nozzle Low Pressure Spray Bar Assembly	156
3 Nozzle Low Pressure Spray Bar Assembly	156
Low Pressure Water Spray Jet, Front and Side Brush	158
Low Pressure Water Spray Jet, Fixed Type	158
High Pressure Water Pump - Arrangement	160
High Pressure Water Pump - Components	162
High Pressure Water Hose End Stowage Arrangement	164
Detergent Feed Valve (Hand Lance)	164
Detergent Bottle and Feed Valve (Water Boom)	164
Fan Wash Assist Arrangement	166
High Pressure Spray System - Layout	168
Automatic Hose Reel - Components	168
High Pressure Water Boom Arrangement	170
High Pressure Front Spray Bar Assembly	172
High Pressure Front Spray Bar Mount	172
Hydraulic Systems	175

Main Control Valve Block (Hydraforce)	176
Brush Control Valve Block (Hydraforce)	178
Main Control Valve Block (pre Hydraforce)	180
Brush Control Valve Block (pre Hydraforce)	182
Front Brush “Stop When Raised” Valve Components	182
Transmission Pump Assembly	184
Suction Fan Pump Assembly	186
Suction Fan Valve Block Assembly (Hydraforce)	186
Suction Fan Motor Assembly	188
Gear Pump Assembly	190
Complete Transmission Assembly	190
Radiator/Cooler Assembly	192
Manifold Assembly	192
Oil Tank Assembly	194
Suction Filter Assembly (Chassis Mounted)	194
Power Steering Regulator Valve	196
Power Steering Regulator Valve (Hydraforce)	196
High Pressure Water Pump Drive Motor	196
Wide Sweep Brush Motor	198
Side/Front Brush Motor	198
Ram - Suction Nozzle Lift	200
Ram - Suction Nozzle Tilt	200
Ram - Wide Sweep Lift	200
Ram - Front Brush Lift	202
Ram - Front Brush Swing Out	202
Ram - Side Brush Lift	202
Ram - Side Brush Swing Out	202
Ram - Hopper Lift	204
Ram - Auto Blanking	204
Ram - Rear Door Open/Close	204
Ram - Cab Lift Assist	204
Rear Door Flow Valve and Pressure Control Assembly (Hydraforce)	206
Rear Door Check Valve (Hydraforce)	206
Rear Door Flow Valve and Pressure Control Assembly	208
Rear Door Check Valve	208
Auto Blanking Valve Single Sweep Assembly	210
Auto Blanking Valve Dual Sweep Assembly	210
Steel Pipes	212
Rubber Hoses - LH Sweep Machines Only	212
Rubber Hoses - RH Sweep Machines Only	213
Rubber Hoses - Dual Sweep Machines Only	213
Rubber Hoses - Common to LH, RH and Dual Sweep Machines	213
Electrical System	215
Electrical Components - Cab	216
Fuse Panel Assembly and Associated Parts	218
Node 4	220
Node 7	220
Node 8	220
Electrical - Wiring Looms	222
Electrical - In Cab	223
Electrical - Switches	223
Electrical - Gantry/Chassis/Hopper	223
Electrical - Head, Rear and Marker Lamps	224
Electrical - Work Lamps, Beacons and Light Bars	224
Labels and Decals	225
Safety, Warning & Information Labels and Decals	226

Street Wash Equipment229

 Street Wash Spray Bar Arrangement 230

 Street Wash Control Valve Assembly 232

 Street Wash Diverting Control Valve Assembly 234

 Street Wash Spray Bar Control Joystick 234

 Street Wash Water Bag Arrangement 236

Engine System

<i>Assembly/Description</i>	<i>Page</i>
Engine	12
Engine Sensors	12
Engine Belt Covers	14
Cooler and Intercooler	16
General Arrangement	16
Exhaust, Cooling and Intercooler	18
General Arrangement	18
Air Cleaner Components	20
Fuel System	22

Item	Part Number	Quantity	Description
Engine General Arrangement *			
1	037141	1	Engine mount, RH
NI	037140	1	Engine mount, LH
2	032883	1	. Coupling, plastic
3	032884	1	. . Hub
4	025031	1	. Bell housing
5	033519	1	. Starter motor
6	033520	1	. Alternator
7	033521	1	. . Drive belt, alternator
8	034060	1	. . . Tensioner, alternator belt
9	034061	1 Idler pulley, alternator belt tensioner
10	037929	1	. Oil filter, complete with O-ring
11	034062	1	. Dip stick and tube
12	034063	1	. . Dip stick only
NI	033346	1	. Cover, timing belt
NI	033544	1	. . Bracket, cover, timing belt
NI	032869	1	. Cover, rocker box, plastic
NI	034057	1	. Gasket, rocker box
NI	034058	1	. Plug, sump drain
NI	034059	1	. . Washer, sump drain plug
13	032564	1	. Gear pump, steering
14	033538	1	. Exhaust gasket
15	036628	1	. Turbo unit
16	026307	1	. Filler cap and O-ring (Oil)
17		4	. Fuel injectors
NI			. Belt covers Page 14
Engine Sensors			
18	034043	1	Boost-pressure and temperature sensor
19	034045	1	Coolant temperature sensor
20	034046	1	Crankshaft speed sensor
21	034048	1	Rail pressure sensor
22	034050	1	Oil-pressure and temperature sensor
23	034051	1	Camshaft speed sensor
24	037936	1	Water in fuel sensor
25	034054	1	Fuel temperature sensor
NI	034049	1	Fuel injector pump sensor

Notes:-
 * For information on parts not listed here, please contact the Scarab Parts Department quoting the machine serial number. The ECU must be matched to the correct serial number prior to shipping from the manufacturer. When procuring a replacement engine ECU, it is important to quote your engine serial number.

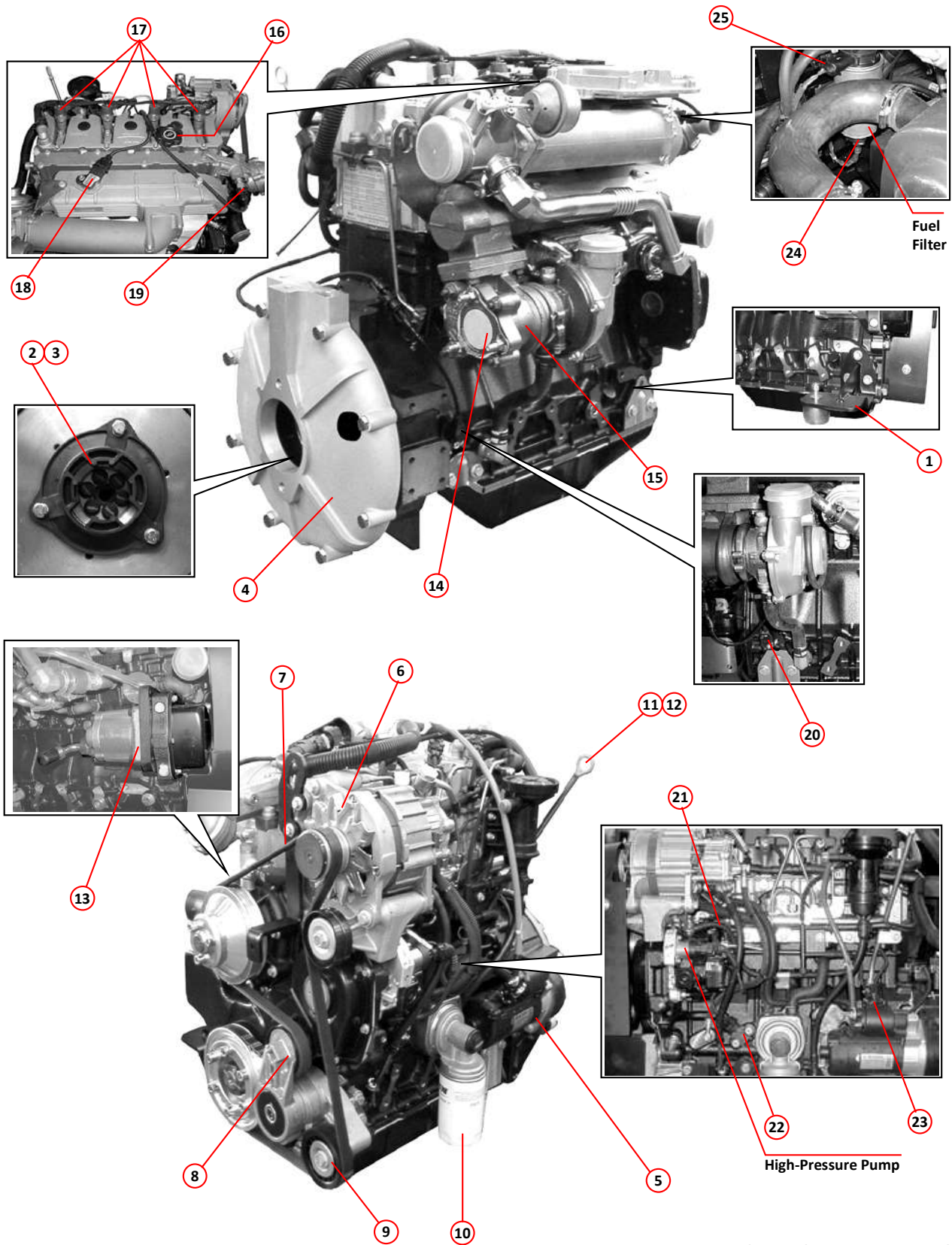

ENGINE - GENERAL ARRANGEMENT

Item	Part Number	Quantity	Description
Engine Belt Covers			
1	040859	1	Upper cover
2	040858	1	. Bracket, upper cover and lifting eye
3	040857	1	. Support, upper cover
NI	014025	1	. . Spacer
4	040863	1	Lower cover (without Air Con)
NI	040864	1	. Bracket, lower cover (without Air Con)
NI	040865	1	. Mount, lower cover (without Air Con)
NI	039932	1	. . Flex-Loc, anti vibration, fastener, M8 (without Air Con)
	011011	1	. . . Setscrew, M8 x 25mm (without Air Con)
	011092	1	. . . Washer, plain, M8 (without Air Con)
	011093	1	. . . Washer, spring, M8 (without Air Con)
5	014681	1	. Blanking grommet (without Air Con)
6	040856	1	Lower cover (with Air Con)
NI	040868	AR	. Flex-Loc, anti vibration, fastener, M6
	011001	AR	Setscrew, M6 x 16mm
	011091	AR	Washer, plain, M6
	011091	AR	Washer, spring, M6
	011071	AR	Nut, M6, Nyloc
7	027715	1	Compressor unit Page 100
8	040860*	1	. Carrier, compressor unit Page 100
NI	039932*	4	. . Flex-Loc, anti vibration, fastener, M8

Notes:-

* If the carrier to be replaced has hank nuts then ensure you ask for the anti vibration fasteners when ordering the carrier.

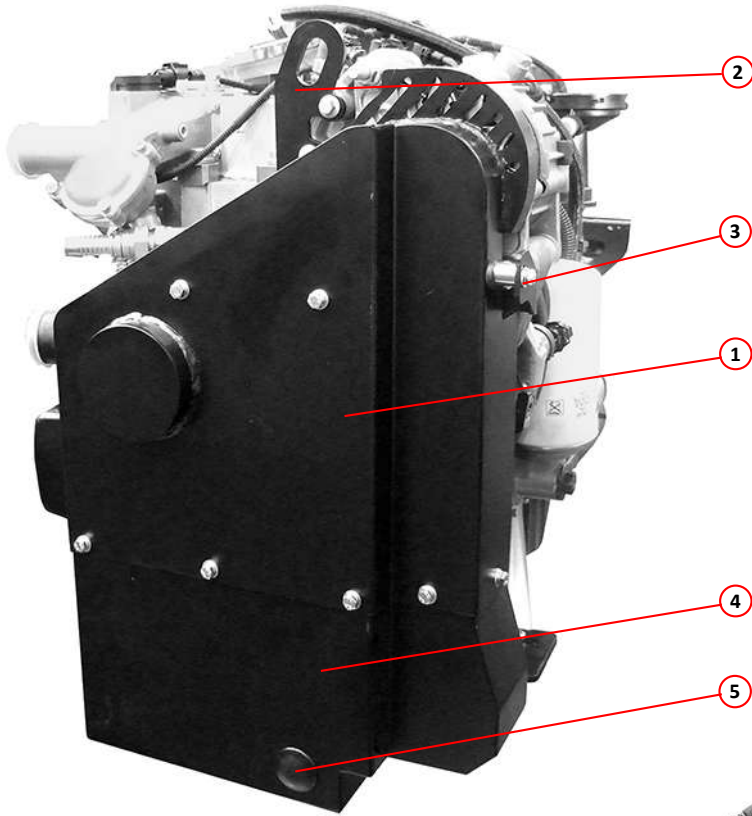

BELT COVERS WITHOUT AIR CON

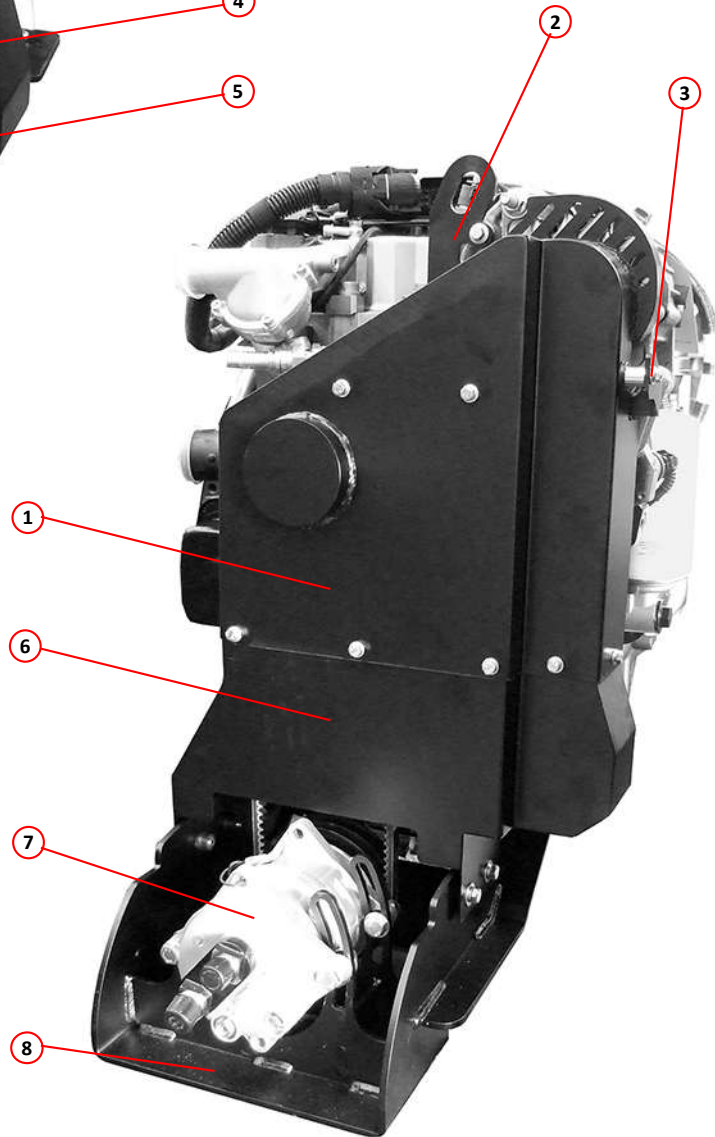

BELT COVERS WITH AIR CON

ENGINE - BELT COVERS

<i>Item</i>	<i>Part Number</i>	<i>Quantity</i>	<i>Description</i>
Cooler and Intercooler General Arrangement			
1	037171	1	Radiator assembly Page 192
2	020517	1	. Expansion bottle
3	020518	1	. Expansion bottle cap
	011087	2	. . Setscrew, M6 x 25mm
	011091	2	. . Washer, M6
	011091	2	. . Washer, spring, M6
4	001035	1	. Pipe, rubber, 8mm bore
5	033361	1	. Pipe, steel, radiator to thermostat
6	034225	2	. Pipe, rubber, radiator to items, 16-18mm
7	003007	7	. . Clamp, worm drive, 35-50mm
8	033362	1	. Pipe, steel, cooler to water pump
9	033832	1	. Pipe, rubber, moulded, intercooler to item 13
10	012927	3	. . Clamp, worm drive, 40-55mm
11	028778	1	. . Clamp, worm drive, hi-torque, 40-70mm
12	032877	1	. Pipe, steel, intercooler LH
	011067	2	. . Setscrew, M6 x 25mm
	011071	2	. . Nut, M6, Nyloc
13	032953	1	. Pipe, steel, intercooler RH
NI	030927	1	. Bracket, pipe support
	005055	1	. . P-clip, 50mm
	011067	1	. . Setscrew, M6 x 25mm
	011087	1	. . Setscrew, M6 x 30mm
	011090	2	. . Washer, M6
	011071	2	. . Nut, M6, Nyloc
14	033831	1	. Pipe, rubber, moulded, intercooler to item 12
15	033217	1	. Elbow, rubber, moulded, Intercooler lower pipe
16	032952	1	. Pipe, rubber, moulded, intercooler to plenum
17	032954	1	. Pipe, rubber, moulded, cooler to thermostat
18	032950	1	. Pipe, rubber, moulded, cooler to water pump
19	012928	1	. . Clamp, worm drive, 45-60mm
20	013409	2	. Anti-vibration mount (Upper)
21	036768	2	. Anti-vibration mount (Lower, blue ring)
	011094	8	. . Washer, M10
	011075	8	. . Nut, M10, Nyloc

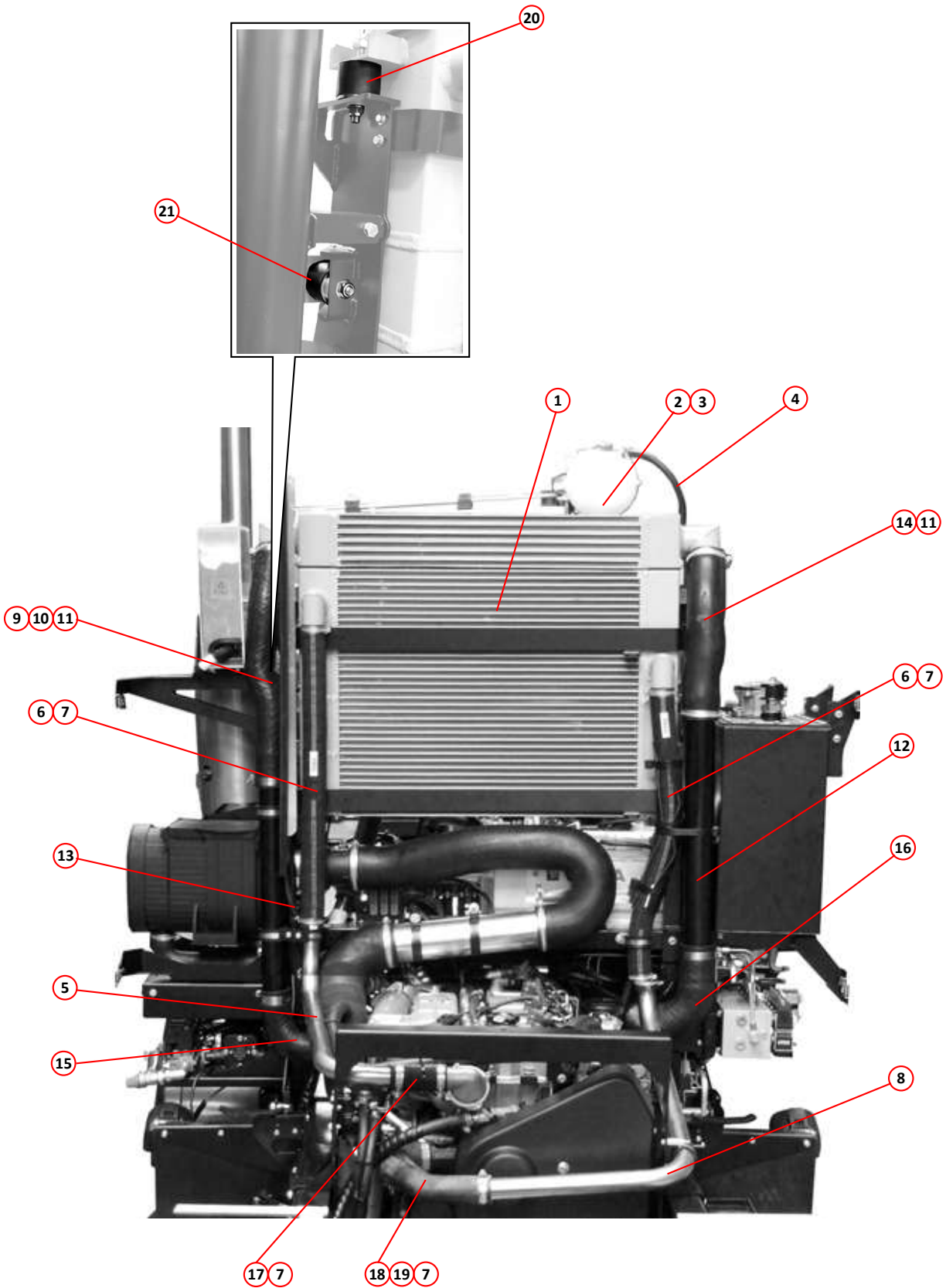

COOLER AND INTERCOOLER

Item	Part Number	Quantity	Description
Exhaust, Cooling and Intercooler General Arrangement			
1	037701	1	DPF low pressure sensor pipe (upper)
2	037702	1	DPF low pressure sensor pipe (lower)
NI	037167	2	. Adaptor, elbow, DPF to sensor
3	010957	AR	. Pipe, rubber, 6mm bore
4	002007	AR	. Pipe, rubber, 8mm bore
5	034079	1	. DPF sensor
6	032873	1	. Bracket, header tank
	011011	2	. . Setscrew, M8 x 25mm
	011093	2	. . Washer, spring, M8
7	032956	1	. Elbow, rubber 16/19
8	010517	2	. . Clamp, worm drive, 18-25mm
9	010909	1	. Tee, $\frac{1}{4}$ " BSP, galvanised, F/F/F
10	010922	1	. . Hose tail, $\frac{1}{4}$ " BSP x $\frac{3}{8}$ " tube
11	010516	4	. . Clamp, worm drive, 11-16mm
12	011171	1	. Elbow, swivel, $\frac{1}{4}$ " BSP, M/F
13	001014	AR	. Pipe, rubber, 10mm bore
14	033372	1	Throttle valve actuator circuit
NI	039596	1	. Cover, vacuum modulator
	011001	2	. . .Setscrew M6 x 16
	011091	2	. . . Washer M6
15	034055	2	. Vacuum modulator
16	006041	1	. Tee, $\frac{1}{8}$ " BSP, F/F/F
17	006042	2	. Hose tail $\frac{1}{8}$ " BSP x 4mm tube
18	006043	2	. Hose tail $\frac{1}{8}$ " BSP x 8mm tube
19	006047	AR	. Pipe, rubber, 4mm bore
20	037937	1	Exhaust silencer
	011031	4	. Setscrew, M10 x 25mm
21	037432	1	. Exhaust, stack pipe
22	037686	1	. Exhaust, rain cap
23	037166	1	. Exhaust, guard
24	036689	1	. Exhaust pipe, manifold to silencer
25	033204	2	. Silencer clamp
	011073	2	. . Nut, M8, Nyloc
26	037164	1	DPF, exhaust mounting bracket (upper)
27	037165	1	DPF, exhaust mounting bracket (lower)
28	036685	1	DPF sensor cover
	011087	1	. Setscrew, M6 x 25mm
	011071	1	. Nut, M6, Nyloc
	011090	1	. Washer, M6
	000028	1	. Screw, slotted round head, 2BA x $\frac{1}{2}$ "

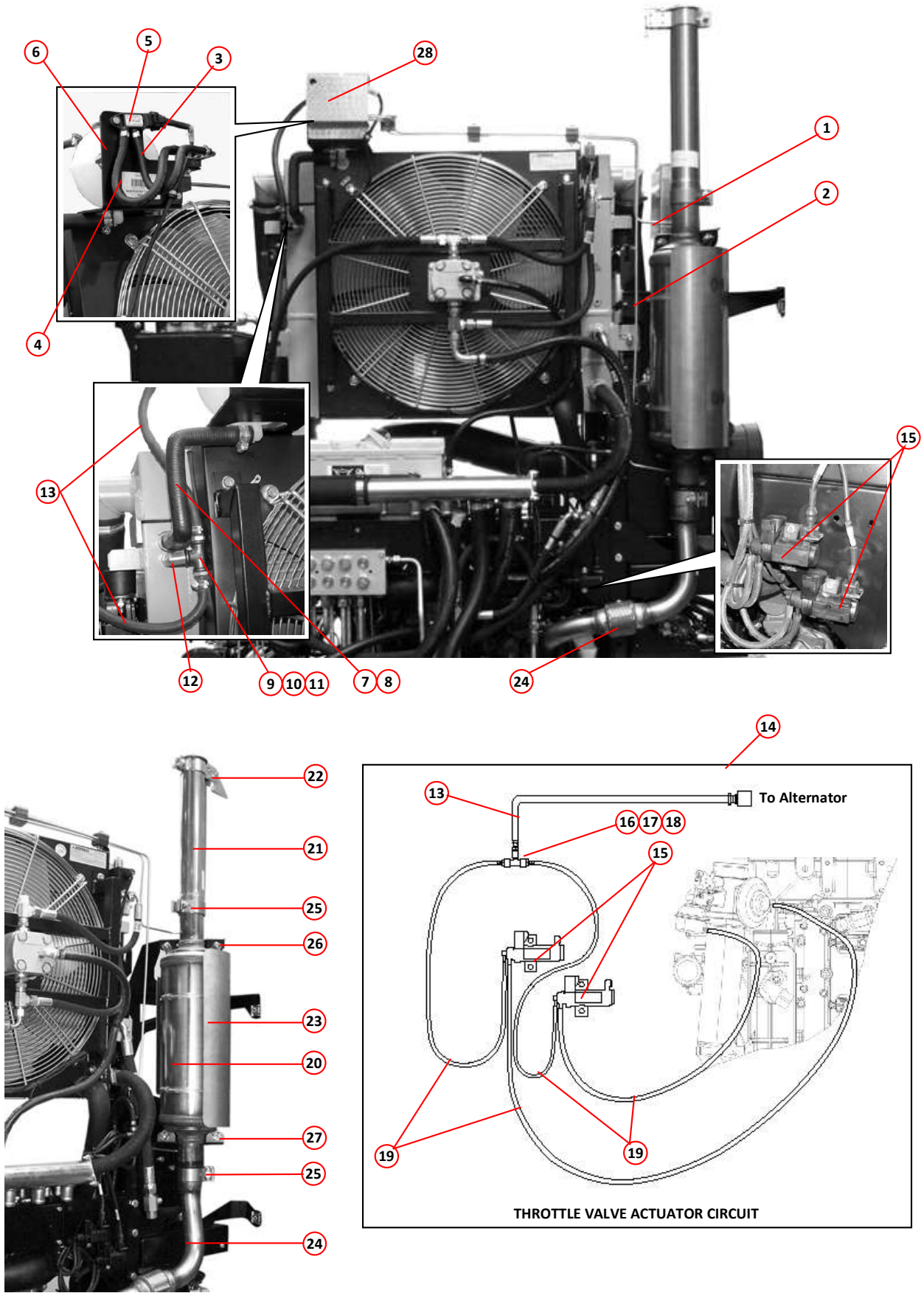

EXHAUST ARRANGEMENT

EXHAUST, COOLING & INTERCOOLER

Item	Part Number	Quantity	Description
Air Cleaner Components			
1	039583	1	Air cleaner, complete assembly Page 50
	011010	4	. Setscrew, hex head, M8 x 20mm
	011092	4	. Washer, M8
2	037931	1	. Pre-air filter
3	037932	1	. Main filter
4	037934	1	. Air filter indicator
5	037146	1	. Hose, rubber, reinforced, air filter evac, upper
6	012927	4	. Clamp, worm drive, 40-55mm
7	037147	1	. Pipe, stainless steel, air filter evac, centre
8	037148	1	. Hose, rubber, reinforced, air filter evac, lower
9	036691	1	. Hose, rubber, reinforced, engine air intake, upper
10	003003	4	. Clamp, worm drive, 90-100mm
11	036838	1	. Pipe, stainless steel, engine air intake, centre
12	037163	2	. Support clamp, centre pipe
	011067	2	. . Setscrew, M6 x 20mm
	011090	4	. . Washer, M6
	011071	2	. . Nut, M6, nyloc
	011011	1	. . Setscrew, hex head, M8 x 25mm
	011092	2	. . Washer, M8
	011073	1	. . Nut, M8, nyloc
13	036690	1	. Hose, rubber, reinforced, engine air intake, lower
14	037934	1	. Indicator, air filter
15	025949	1	. . Hose tail, 10mm x 1" pitch x 8mm tube
16	002007	AR	. . Hose, rubber, 8mm bore
17	010964	2	. . . O-clip, 9/16

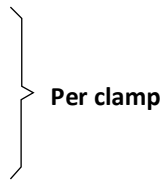

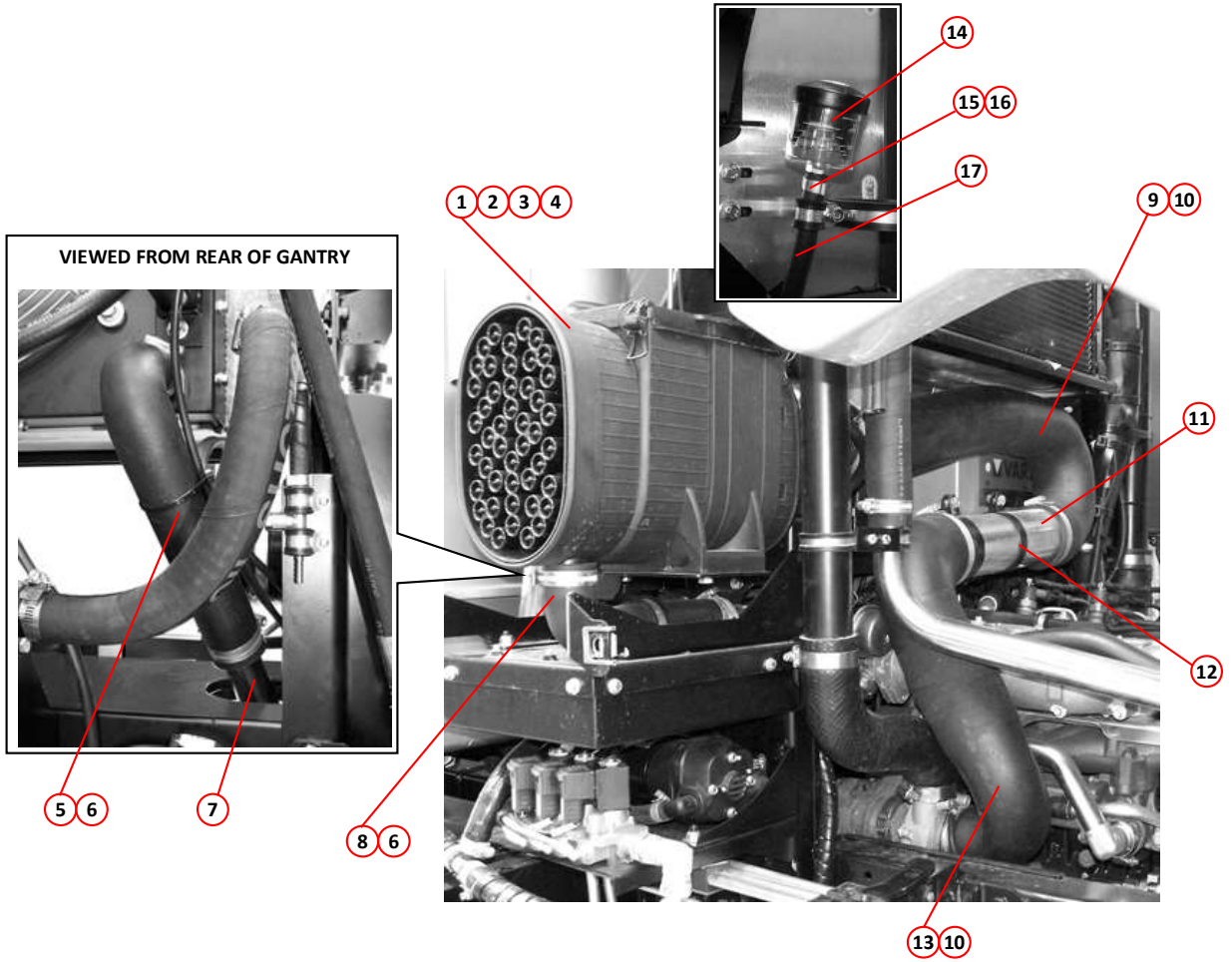

AIR CLEANER COMPONENTS

Item	Part Number	Quantity	Description
Fuel System			
1	018204	1	Fuel tank assembly (comprises items 2 (or 2a) to 10 + 14)
2	032654	1	. Tank, fuel (single sweep machines)
2a	036236	1	. Tank, fuel, anti-syphon (optional on single sweep machines)
3	032652	1	. Sender, fuel level
4	032653	1	. . Ring, locking
5	032805	1	. . Ring, sealing
NI	022237	1	. . Harness, electrical, fuel sender unit
6	013953	2	. Bracket, mounting, fuel tank
	011013	8	. . Setscrew, M8 x 35mm
	034280	8	. . Spacer
	011073	8	. . Nut, M8, Nyloc
7	013954	2	. Strap, fuel tank
	000059	2	. . Screw, socket cap head, M8 x 5 0mm
	011073	2	. . Nut, M8, Nyloc
	000080	2	. . Nut, $\frac{5}{16}$ " UNF, Nyloc
8	010945	1	. Drain plug, magnetic, $\frac{3}{8}$ " BSP, fuel tank
9	011153	1	. . Seal, Dowty, $\frac{3}{8}$ " BSP
10	033330	1	. Cap assembly, fuel tank
NI	025892	1	. Cap, locking, fuel tank (optional)
11	034145	AR	. Hose, fuel, 10mm bore
	010964	2	. . Clip, hose, $\frac{9}{16}$ "
12	037930	1	. Fuel Filter
	011032	2	. . Setscrew, M8 x 30mm
	011075	2	. . Nut, M8, Nyloc
	032872	1	Bracket
	011067	2	. . Setscrew, hex, M6 x 20mm
	011071	2	. . Nut, M6
13		1	Injector pump arrangement
14	033359	1	. Earth lead
15	010922	2	. Hose connector $\frac{1}{4}$ " BSP x $\frac{3}{8}$ "
16	011152	2	. . Seal, Dowty $\frac{1}{4}$ " BSP
17	032655	1	. Tank, fuel (rear mounted dual sweep machines)
	011031	4	. . Setscrew, M10 x 25mm
	011094	4	. . Washer, M10
	011075	4	. . Nut, M10, Nyloc
18	038162	1	. Pre-filter, fuel
	038157	1	. . Hose tail, M14 x 1.5 pitch x 10mm pipe
	002172	1	. . Hose tail, banjo elbow, M14 x 1.5 x 10mm pipe
	002170	1	. . Hose tail, banjo bolt, M14 x 1.5 pitch
	002171	3	. . Washer, copper, M14

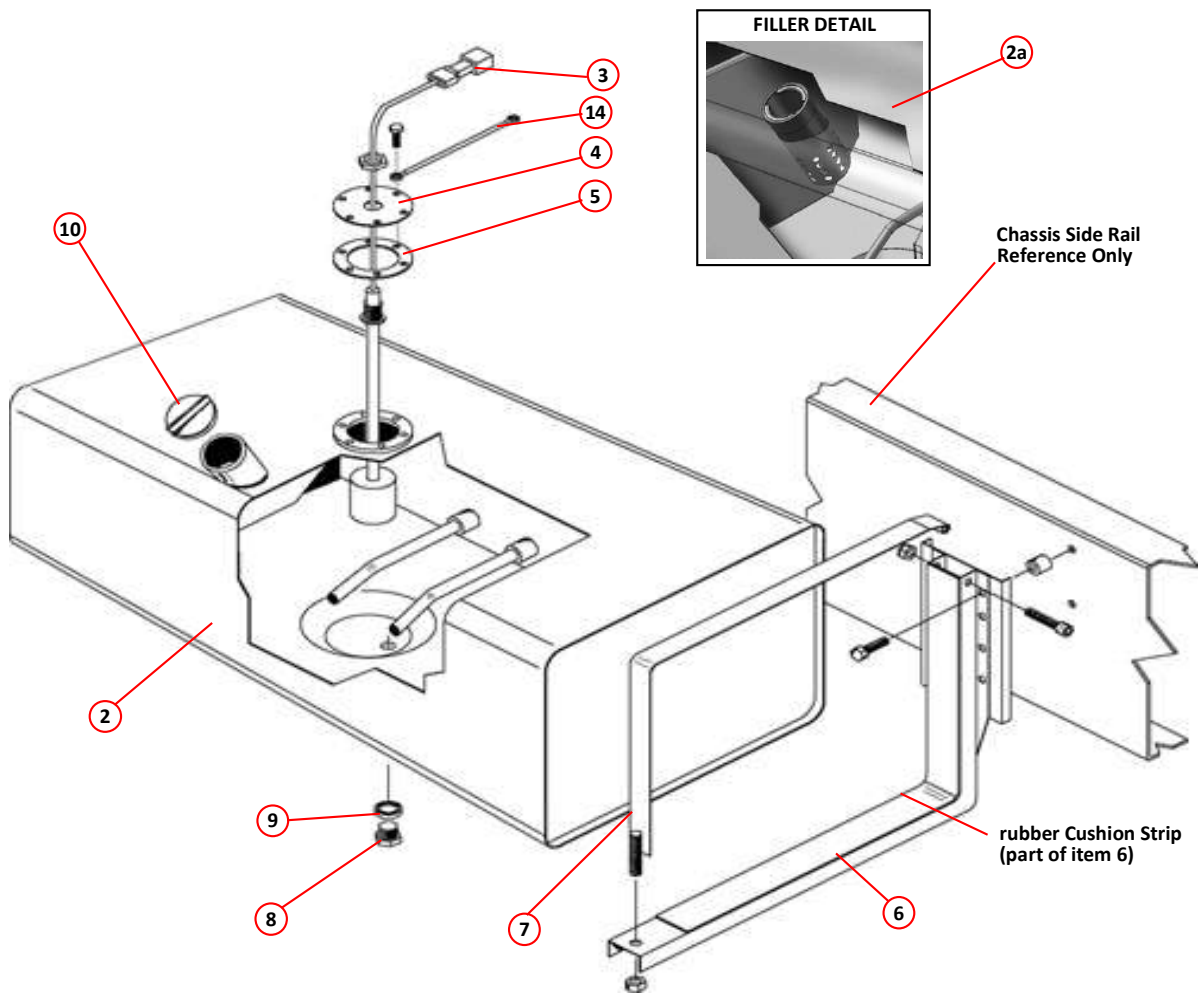
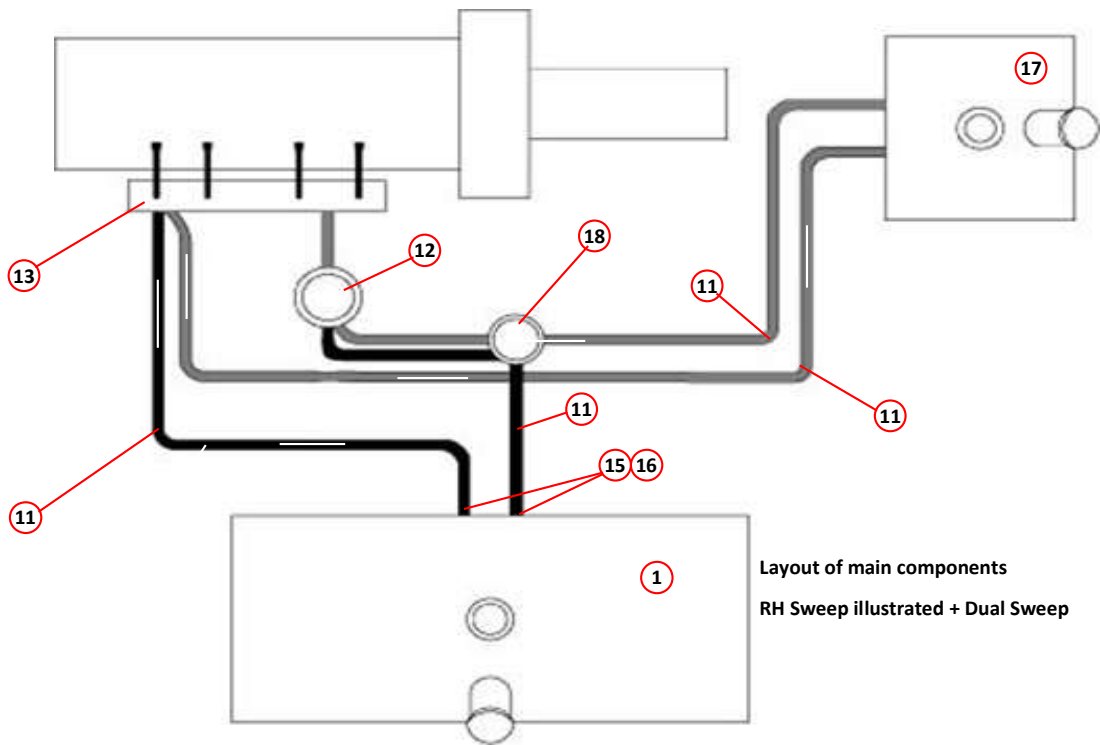

FUEL SYSTEM ARRANGEMENT

<i>Assembly/Description</i>	<i>Page</i>
Drive line - General Arrangement	26
Drive Motor Assembly	28
Prop Shaft General Arrangement	30
Rear Axle Assembly.....	32
FPW Drive Axle Assembly.....	34
FPW Drive Axle, Axle Components	36
FPW Drive Axle, Gearbox Components.....	38

<i>Item</i>	<i>Part Number</i>	<i>Quantity</i>	<i>Description</i>
Drive line - General Arrangement			
1	024672SE	1	Drive motor 51V110 Page 28
2	034879	1	Prop-shaft Page 30
3	034878	1	Rear axle assembly Page 32
4	021730	1	Oil filter (suction filter assembly) Page 194
NI	024516	1	Transmission pump assembly Page 184

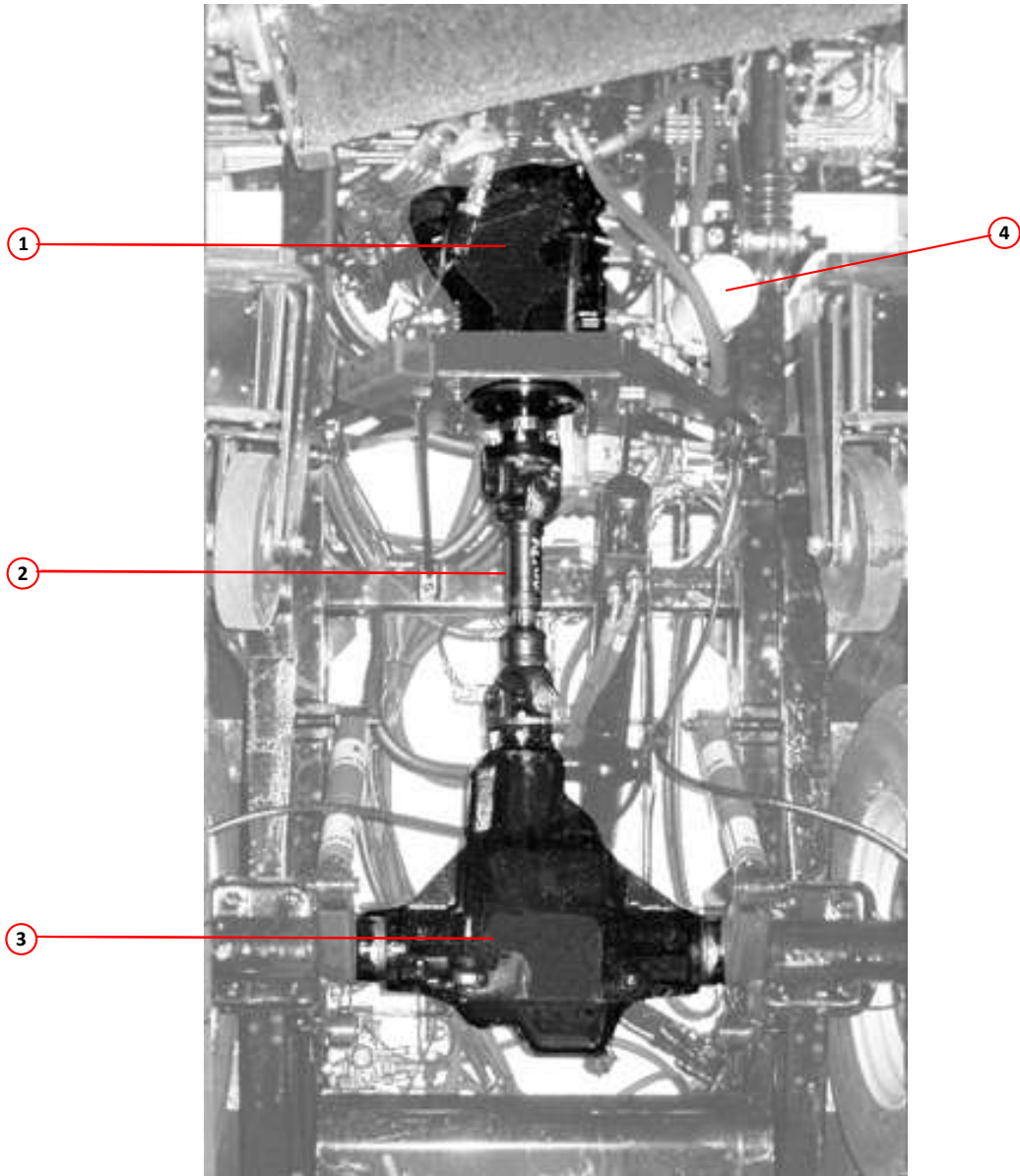

UNDERSIDE OF VEHICLE - SHOWING DRIVELINE

DRIVELINE - GENERAL ARRANGEMENT

Item	Part Number	Quantity	Description
Drive Motor Assembly			
1	024672SE	1	Drive motor, 51V110-T
	011137	4	. Setscrew, M18 x 50mm
	011139	4	. Nut, M18, Nyloc
2	011265	2	. Adaptor, $1\frac{1}{16}$ " UNF x $1\frac{1}{2}$ " BSP, M/M
3	011234	1	. Elbow, hose tail, $\frac{1}{2}$ " BSP x $\frac{5}{8}$ " hose
4	010517	2	. . Clamp, worm drive, 18-25mm
5	002073	1	. Test point, $\frac{9}{16}$ " UNF
6	002001	4	. Flange, split, 1
	000036	7	. . Screw, socket cap head, $\frac{7}{16}$ " UNC x $1\frac{3}{4}$ "
	000025	1	. . Bolt, $\frac{5}{8}$ " UNC x $1\frac{1}{2}$ "
	000039	8	. . Washer, $\frac{5}{8}$ " , spring
7	031320	1	. Hose, rubber, transmission, 635mm, REVERSE
8	031321	1	. Hose, rubber, transmission, 660mm, FORWARD
9	026179	1	. Pulse Pick Up (PPU)
10	025410	1	. . Connector lead (PPU)
11	025040	1	. Adaptor, restrictor No 12, $\frac{9}{16}$ " UNF x $\frac{1}{4}$ " BSP x $\frac{1}{32}$ " orifice
12	011171	1	. Elbow, Swivel, $\frac{1}{4}$ " BSP, F/F
13	002014	1	. . Adaptor, $\frac{1}{4}$ " BSP, M/F
14	030529	1	. . Pressure switch, hydrostatic braking
15	026033	1	. Plug, solenoid
16	027238	1	. Solenoid and coil, 12 Volt
NI	026032	1	. . Coil, 12 Volt
17	021329	1	. Motor support
	011031	4	. . Setscrew, M10 x 25mm
	011075	4	. . Nut, M10, Nyloc
18	013955	2	. Strut
	011031	4	. . Setscrew, M10 x 25mm
	011075	4	. . Nut, M10, Nyloc
19	014747	1	. Coupling, (to prop shaft flange)
	000025	1	. . Setscrew, hex head, $\frac{5}{8}$ " UNC x $1\frac{1}{2}$ "
	013439	1	. . Washer, special
NI	013518	1	. O-Ring
NI	013523	1	. O-Ring
NI	020577	1	. V-Ring, motor
NI	036458	1	. Seal
NI	014693*	1	. . Buffer, rubber
	000072	2	. . Setscrew, M10 x 45mm
	011074	2	. . Washer, M10, plain
	011075	2	. . Nut, M10, Nyloc
20	044675	1	. Voltage stabiliser

Notes:-

* The rubber buffer is fitted to the right hand side of the motor support, on right hand and dual sweep machines only.

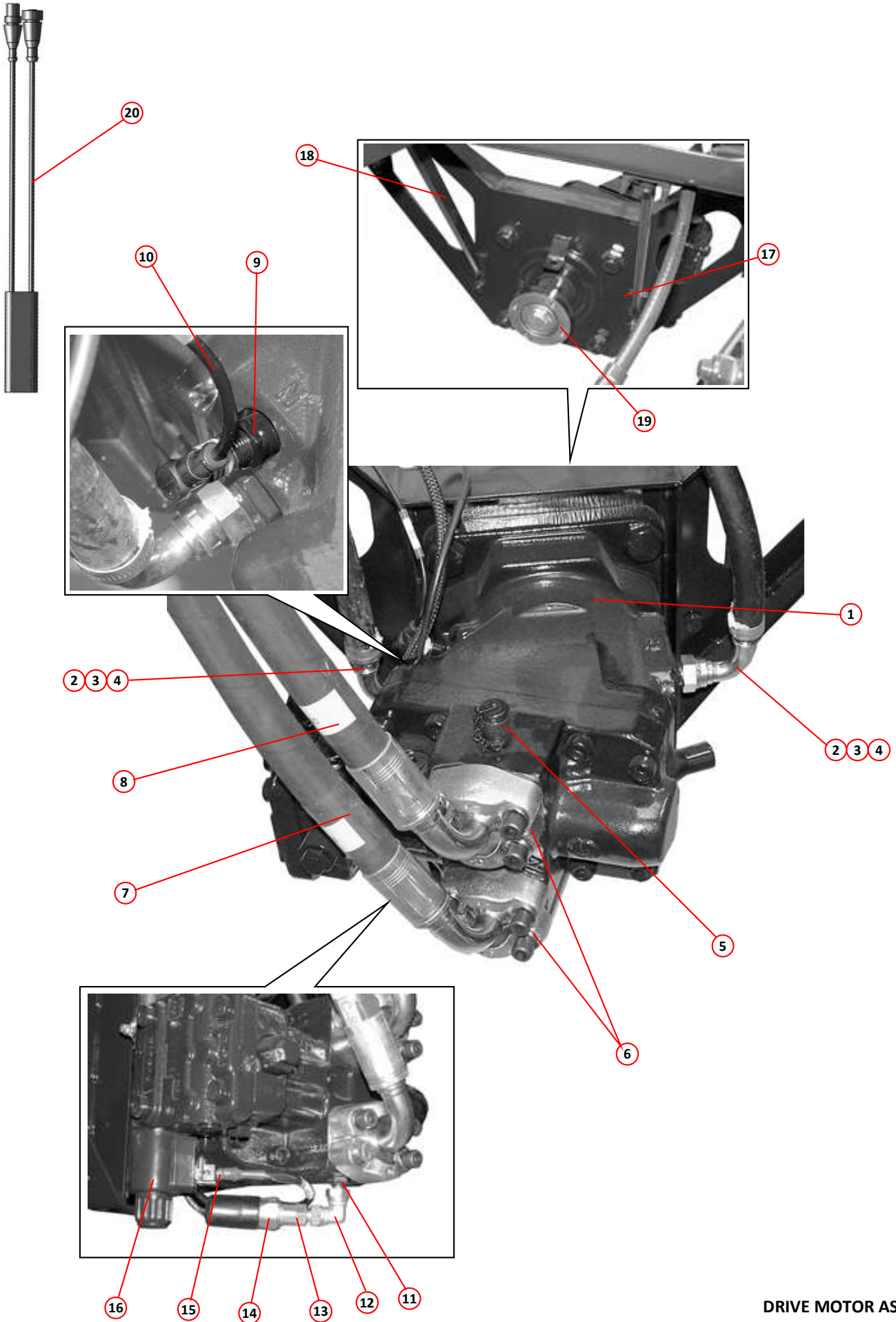

DRIVE MOTOR ASSEMBLY

<i>Item</i>	<i>Part Number</i>	<i>Quantity</i>	<i>Description</i>
Prop Shaft General Arrangement			
1	034879	1	Prop-shaft (blue) Page 34
	011026	4	. . Setscrew, hex head, $\frac{3}{8}$ " UNF x $1\frac{1}{4}$ " (Prop)
	011405	4	. . Nut, hex, $\frac{3}{8}$ " UNF, Nyloc (Prop)
2	014747	1	. Coupling, drive motor
	000078	4	. . Bolt, hex head, $\frac{3}{8}$ " UNF x $1\frac{1}{2}$ " (Prop)
	011405	4	. . Nut, hex, $\frac{3}{8}$ " UNF, Nyloc (Prop)

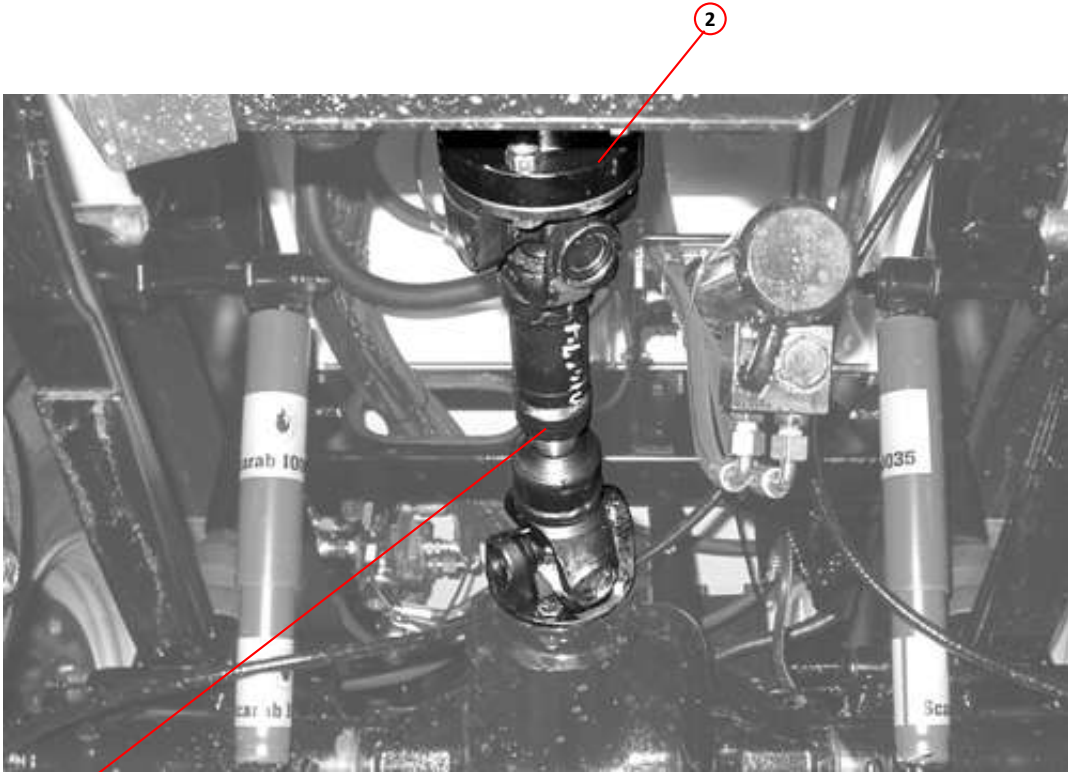

UNDERSIDE OF VEHICLE

PROP-SHAFT GENERAL ARRANGEMENT

<i>Item</i>	<i>Part Number</i>	<i>Quantity</i>	<i>Description</i>
Rear Axle Assembly			
1	025573	1	Rear axle assembly complete with hubs, brakes and drums
2	020162	1	. Drive flange
3	020164	1	. . Pinion oil seal
3	045888	1	. . Pinion oil seal (Front bearing oil seal for FPW axle Part No 042549)
4	020165	1	. . Pinion oil thrower
5	020166	1	. . Pinion tail bearing
6	020167	1	. . Collapsible spacer
7	020169	1	. . . Pinion washer
8	020168	1	. . . Pinion locknut
9	020206	1	. Rear cover
10	020214	2	. Half shaft
11	020215	2	. . Hub oil thrower
12	020216	2	. . Hub seal
13	020218	2	. . Hub bearing, inner
14	020220	2	. . Hub bearing, outer
15	020221	2	. . Locknut, hub inner
16	020222	2	. . . Lock washer
17	020223	2	. . . Locknut, hub outer
18	020224	2	. . . Gasket
19	020226	16 Bolt, special, half shaft
20	020180*	1	. . . Hub and stud assembly, LH
21	020219	2 Hub
22	020213	6 Wheel stud, LH
NI	020181*	1	. . . Hub and stud assembly, RH
	020219	2 Hub
	020217	6 Wheel stud, RH
23	020211	1	. Axle breather
24	020212	1	. Drain plug, magnetic
NI	034005	AR	. Packer shim

Notes:-

* The hub and stud assembly includes both the relevant hub and studs.

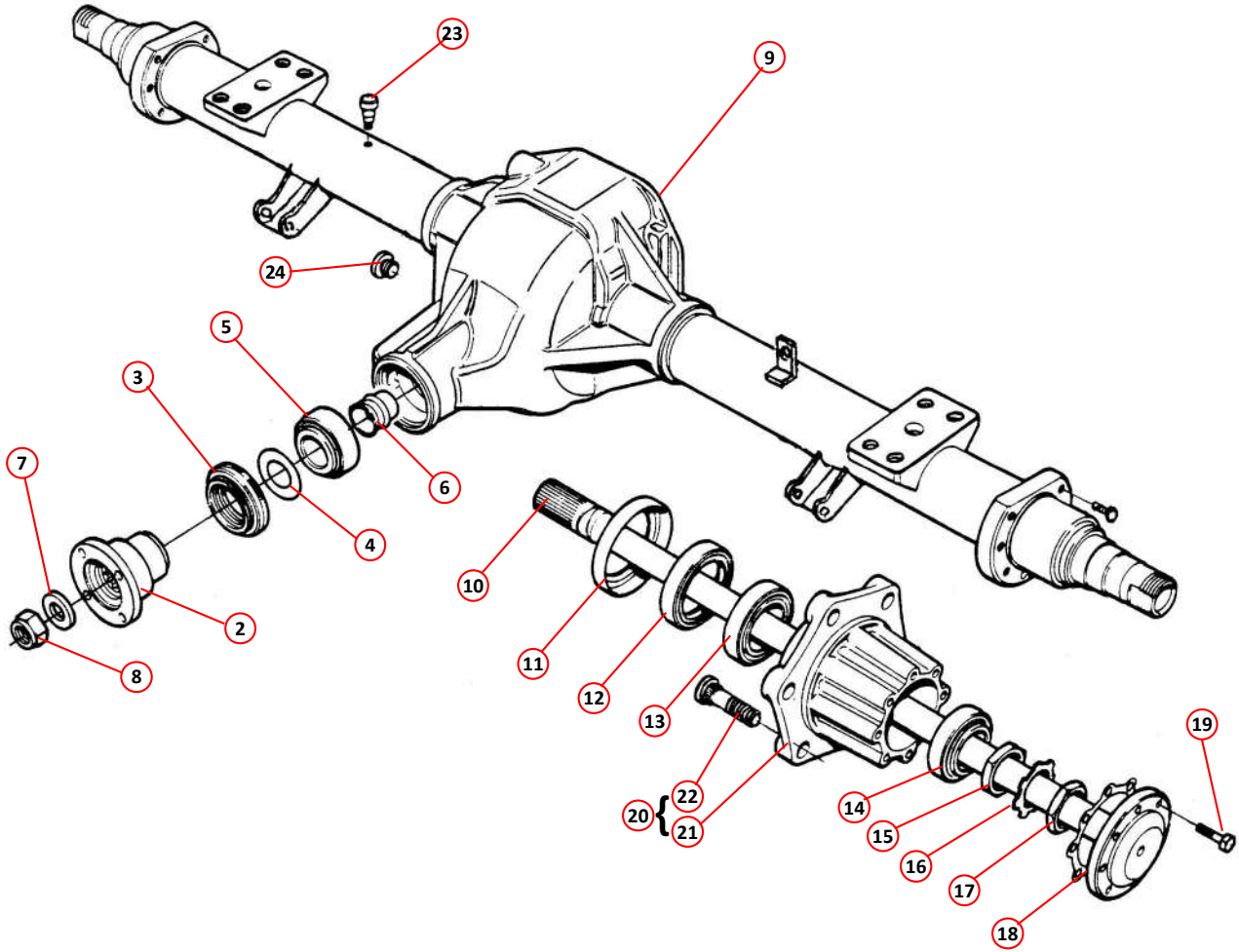
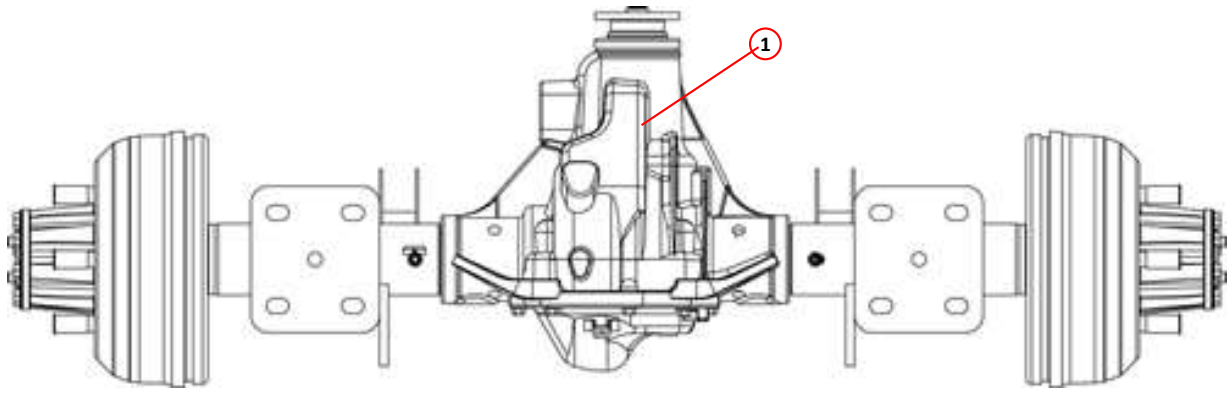

REAR AXLE ASSEMBLY

Item	Part Number	Quantity	Description
FPW Drive Axle Assembly			
(Can also be Retro fitted to existing machines)			
	043114	1	Replacement drive axle assembly complete with following parts
1	042549	1	Rear axle Minor (FPW) 5.22:1 ratio, includes hub, brakes and drums
	042795	1	Bracket LAV (2014-ON) (FPW axle)
	043105	1	Brake pipe bracket (FPW axle)
	014207	AR	Brake pipe bundy, $\frac{3}{16}$ " (4.76) O/D
	014209	4	Nut, M10, short, $\frac{3}{16}$ " Kunifir
	014818	1	Brake hose adaptor
	014195	3	Pipe clip, single, \varnothing 5mm
	011030	1	High tensile setscrew M10 x 20mm
	011075	1	Nut, M10, Nyloc
	034879	1	Propshaft Page 30
	011026	4	High tensile setscrew, $\frac{3}{8}$ " UNF x $1\frac{1}{4}$ "
	000078	4	High tensile bolt, $\frac{3}{8}$ " UNF x $1\frac{1}{2}$ "
	011405	8	Nut, $\frac{3}{8}$ " UNF P, Nyloc
2	038180	1	Spring pad, LH
3	038181	1	Spring pad, RH
4	014634	2	Damper bracket

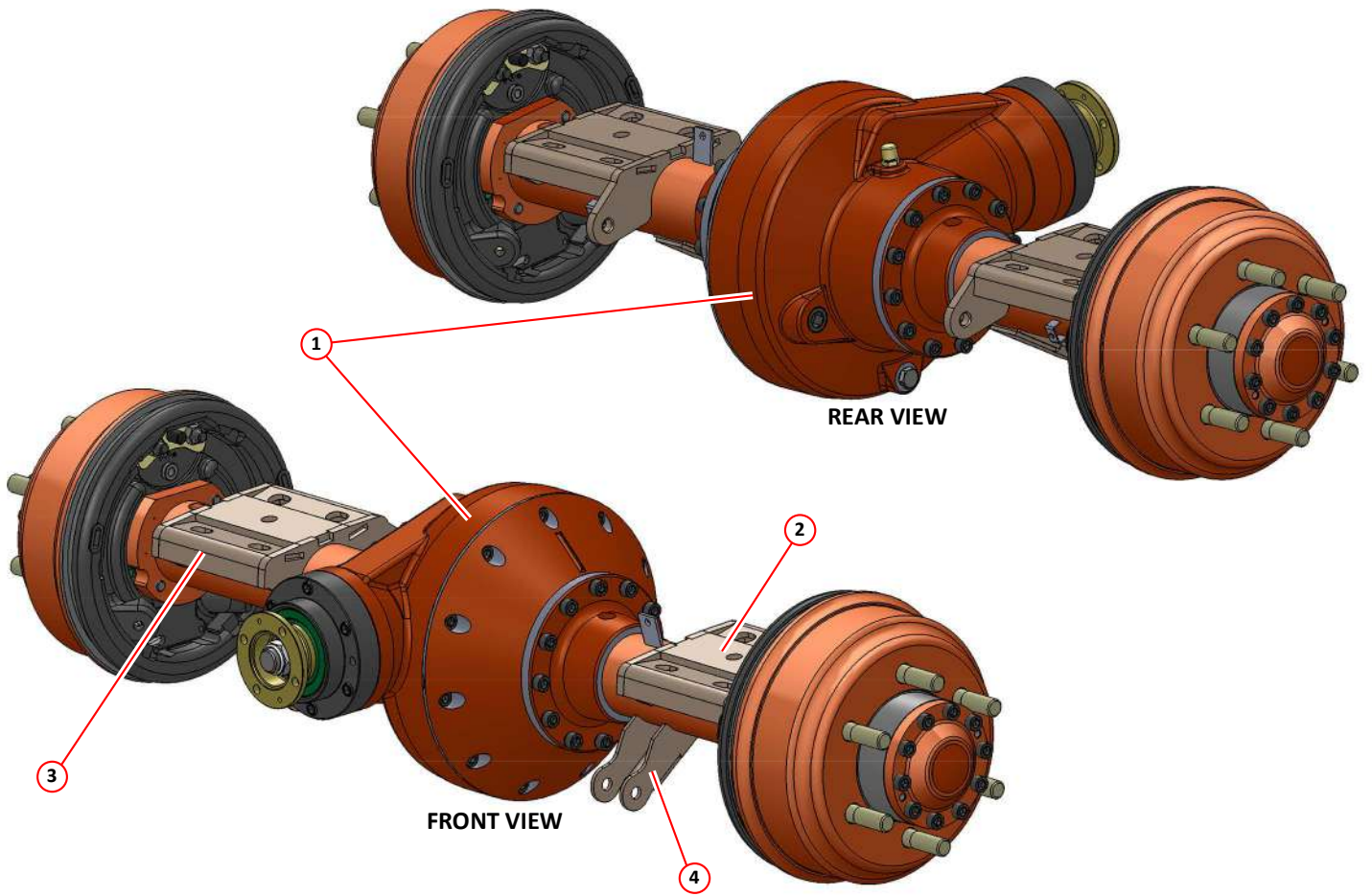

FPW DRIVE AXLE ASSEMBLY

Item	Part Number	Quantity	Description
FPW Drive Axle, Axle Components			
1		1	Gearbox motor assembly
2		1	Axle tube assembly, right hand
3		1	Axle tube assembly, left hand
4		2	O ring, ID \varnothing 136 x 2.5, (1 each side)
5		2	Oil seal, \varnothing 28 x \varnothing 50 x 7, (1 each side)
6	044943	24	Socket cap screw, M10 x 30, (12 each side)
7	045159	1	Brake assembly 10" x 2.75", right hand Page 76
8	045158	1	Brake assembly 10" x 2.75", left hand Page 76
9	045162	12	Socket cap screw $\frac{7}{16}$ " x $\frac{3}{4}$ " UNF, (6 each side)
10	044991	2	Oil seal, \varnothing 80 x \varnothing 100 x 8, (1 each side)
11	044989	2	Abutment ring, (1 each side)
12	045129	2	Bearing, \varnothing 60 x \varnothing 95 x 27, (1 each side)
13	045156	2	Wheel hub M/C, (1 each side)
14	045128	2	Bearing, \varnothing 60 x \varnothing 95 x 23, (1 each side)
15	045002	2	Adjusting nut, M60 x 2
16	045161	6	Wheel stud, right hand
17	045160	6	Wheel stud, left hand
18	020199	2	Brake drum, (1 each side) Page 76
19	045157	2	Hub gasket, (1 each side)
20	044990	2	Countersunk screw M8 x 20, (1 each side)
21	044943	20	Socket cap screw, M10 x 30, (10 each side)
22	045131 *	2	Drive shaft assembly, (1 each side), <i>includes items 23, 24 and 25</i>
23	045165	4	Circlip, \varnothing 38 external, (2 each side)
24	045164	2	Drive flange, (1 each side)
25	045166	2	Blanking disk, (1 each side)

Notes:-

* Drive shaft, is comprised of items 22, 23, 24 and 25. If just the shaft is required the please contact Scarab Parts Department.

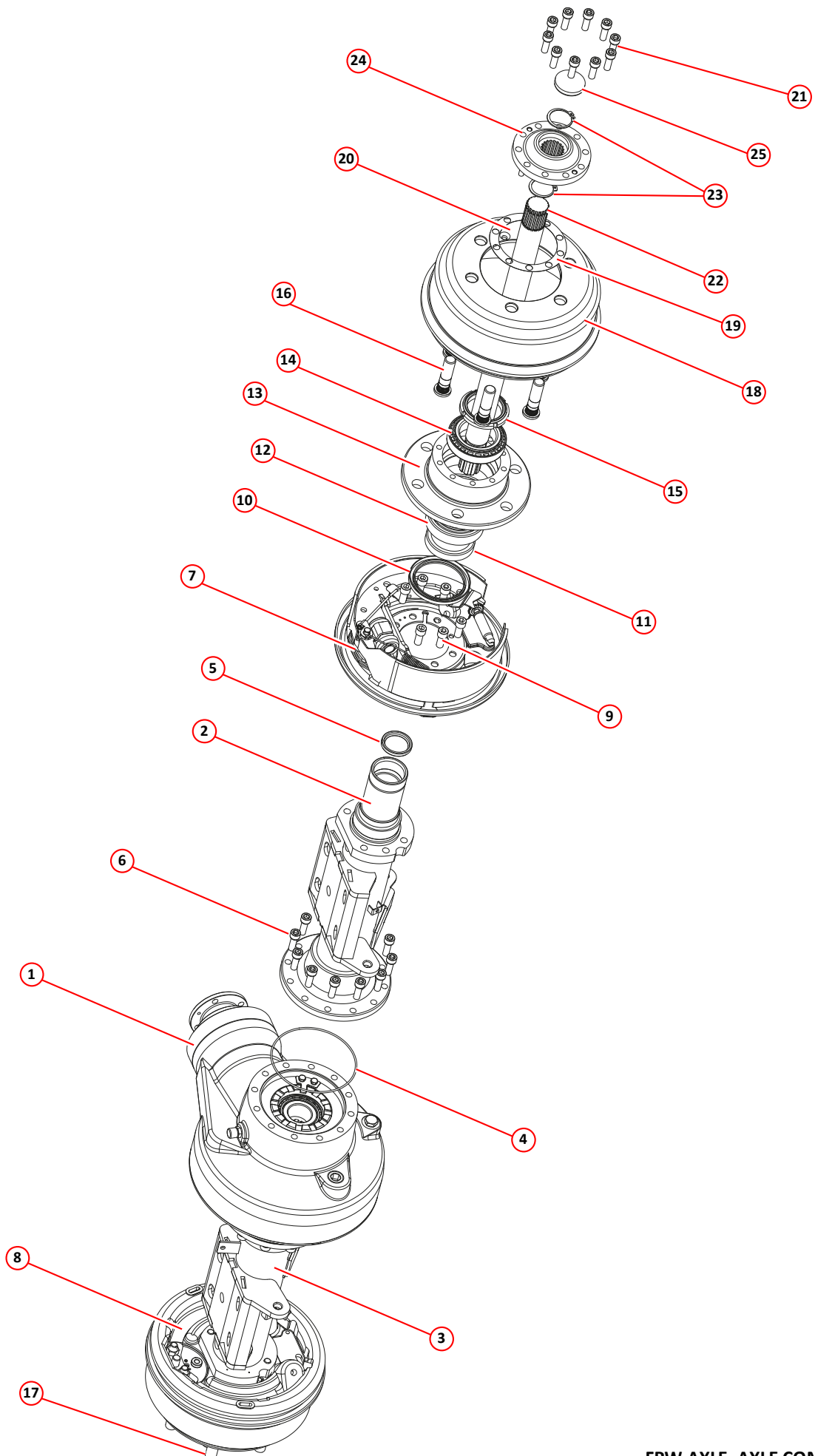

<i>Item</i>	<i>Part Number</i>	<i>Quantity</i>	<i>Description</i>
FPW Drive Axle, Gearbox Components			
1		1	Gearbox case
2		1	Gearbox lid
3		11	Socket cap screws, M10 x 25
4	045921	1	Hypoid pinion and crown wheel
5		1	Breather assembly
6	045923	1	Nilos ring 33209AV
7	045571	1	Bearing, $\varnothing 40 \times \varnothing 100 \times 38.25$
8	045924	1	Bearing spacer
9	045572	1	Bearing, $\varnothing 1.625'' \times \varnothing 3.375'' \times 1.1875''$
10	045558	1	Oil seal, viton twin lip, $\varnothing 60 \times \varnothing 90 \times 10$
11	045559	1	O ring ID $\varnothing 105 \times 2.5$
12	045925	1	Shim pack
13		1	Locking collar
14		6	Socket cap screw, M8 x 35
15	045557	1	Drive flange
16	045922	1	Heavy washer, M24
17	045556	1	Thin Nyloc nut, M24
18		1	Level plug
19		1	Copper washer
20		1	Drain plug assembly, $\frac{1}{4}''$ BSP
21		1	Locking ring
22	045930	2	Taper roller $\varnothing 2.25'' \times \varnothing 3.6125'' \times 0.826''$
23		8	Bolt M10 x 100
24		8	V5 12 washer
25		8	Spring washer M10
26		8	Plain nut M10
27		1	Differential case male
28		1	Differential case female
29		16	Bolt M12 x 35
30	045926	2	Differential pinion gear
31	045927	2	Cone thrust washer
32		1	Differential spider (2 gears)
33	045929	2	Side gear
34	045928	2	Thrust washer
35		1	Lock tab
36		2	
37		2	

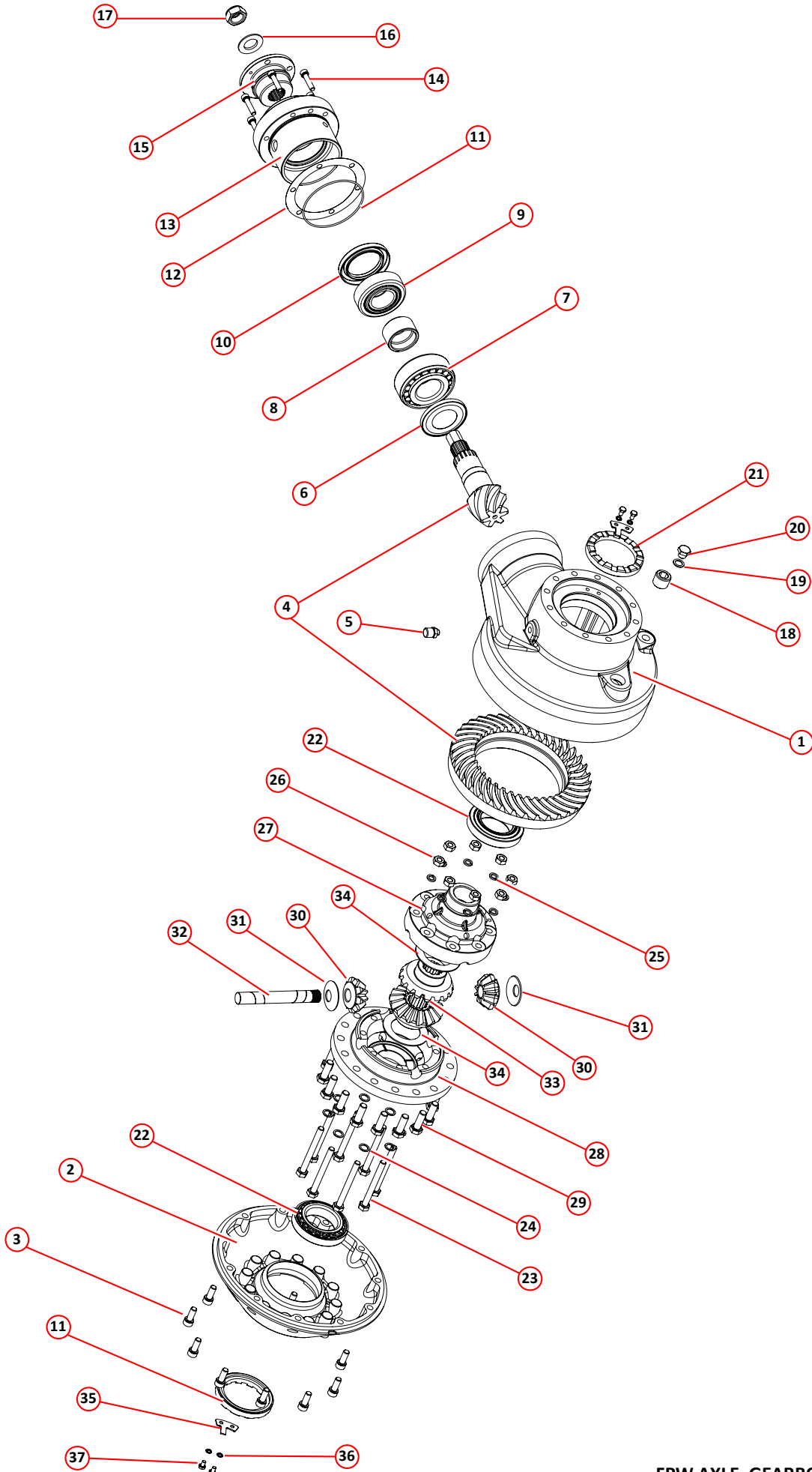

<i>Assembly/Description</i>	<i>Page</i>
Chassis General Arrangement	42
Chassis General Arrangement	44
Chassis General Arrangement	46
Rear Lights, Bumper and Brackets (April 2013 - on)	48
Bumper Conversion (April 2013 - on)	48
Gantry General Arrangement	50
Gantry General Arrangement	52
Front Mud Flap Assembly	54
Rear Mudguard Assembly	54
Front Suspension Assembly	56
Rear Suspension Assembly	58
Front Axle Steering/Hub Arrangement	60
LHD from June 2011, RHD from August 2013	60
Steering Arrangement	62
LHD from June 2011, RHD from August 2013	62
Front Axle Steering/Hub Arrangement	64
LHD Pre June 2011, RHD Pre August 2013	64
Front Axle Steering/Hub Arrangement	66
LHD Pre June 2011, RHD Pre August 2013	66
Steering Arrangement	68
LHD Pre June 2011, RHD Pre August 2013	68
Teal Hand Wash Basin Assembly	70

Item	Part Number	Quantity	Description
Chassis General Arrangement			
1	013498	1	Bumper, front
	011031	6	. Setscrew, M10 x 25mm
	011075	6	. Nut, M10, Nyloc
	013662	4	. . Bush
2	027734	2	Cab pivot bracket
3	027731	2	. Bush (brass bush insert 027732)
	011011	8	. . Setscrew, M8 x 25mm
	011073	8	. . Nut, M8, Nyloc
4	013426	1	Footplate
5	022320	1	Step, LH
NI	022321	1	Step, RH
	011010	4	. Setscrew, M8 x 20mm
	011073	4	. Nut, M8, Nyloc
6	014845	1	Pocket, cab prop (always fitted nearside)
	011075	2	. Nut, M10, Nyloc
7	036403	1	. Cab prop guide
	000052	2	. . Setscrew, M5 x 16mm
	0001551	2	. . Nut, M5, Nyloc
8	013465	2	Hopper guide
	011011	2	. Setscrew, hex head, M8 x 25mm
	011073	2	. Nut, M8, Nyloc
9	013402	2	Mudguard
10	013404	4	. Bracket, mudguard
	011032	3	. . Setscrew, M10 x 30mm
	011075	3	. . Nut, M10, Nyloc
11	011640	1	Pin, hopper hinge Page 130
12	014001	2	. Bush (pair)
	000050	4	. . Screw, slotted round head, 2BA x $\frac{3}{4}$ "
	000005	4	. . Nut, 2BA, Nyloc
13	013996	1	. Bush (pair)
	000050	2	. . Screw, slotted round head, 2BA x $\frac{3}{4}$ "
	000005	2	. . Nut, 2BA, Nyloc
14	033232	1	Handbrake abutment Page 78
	011010	2	. Setscrew, M8 x 20mm
	011073	2	. Nut, M8, Nyloc
15	028786	1	Rear bumper, under run
16	033017*	1	. Bracket, rear bumper, LH
NI	033018*	1	. Bracket, rear bumper, RH
NI	028785	2	. End cap, rear bumper
	011414	2	. . Coach bolt, M8 x 30mm
	011073	1	. . Nut, M8, Nyloc
17	011757	1	Hopper safety prop pocket (always fitted nearside) Page 130
	011001	2	. Setscrew, M8 x 25mm
	011073	2	. Nut, M8, Nyloc
18	032562	1	Bracket, cab support, LH
NI	032563	1	Bracket, cab support, RH
	011011	8	. Setscrew, M8 x 25mm
	011073	8	. Nut, M8, Nyloc
19	023346	1	Bracket, wide sweep tow, LH Page 106
NI	023347	1	Bracket, wide sweep tow, RH Page 106
	011031	2	. Setscrew, M10 x 25mm
	011043	2	. Bolt, M10 x 70mm
	011073	4	. Nut, M8, Nyloc

Notes:-

* For machines built after April 2013 see Page 48.

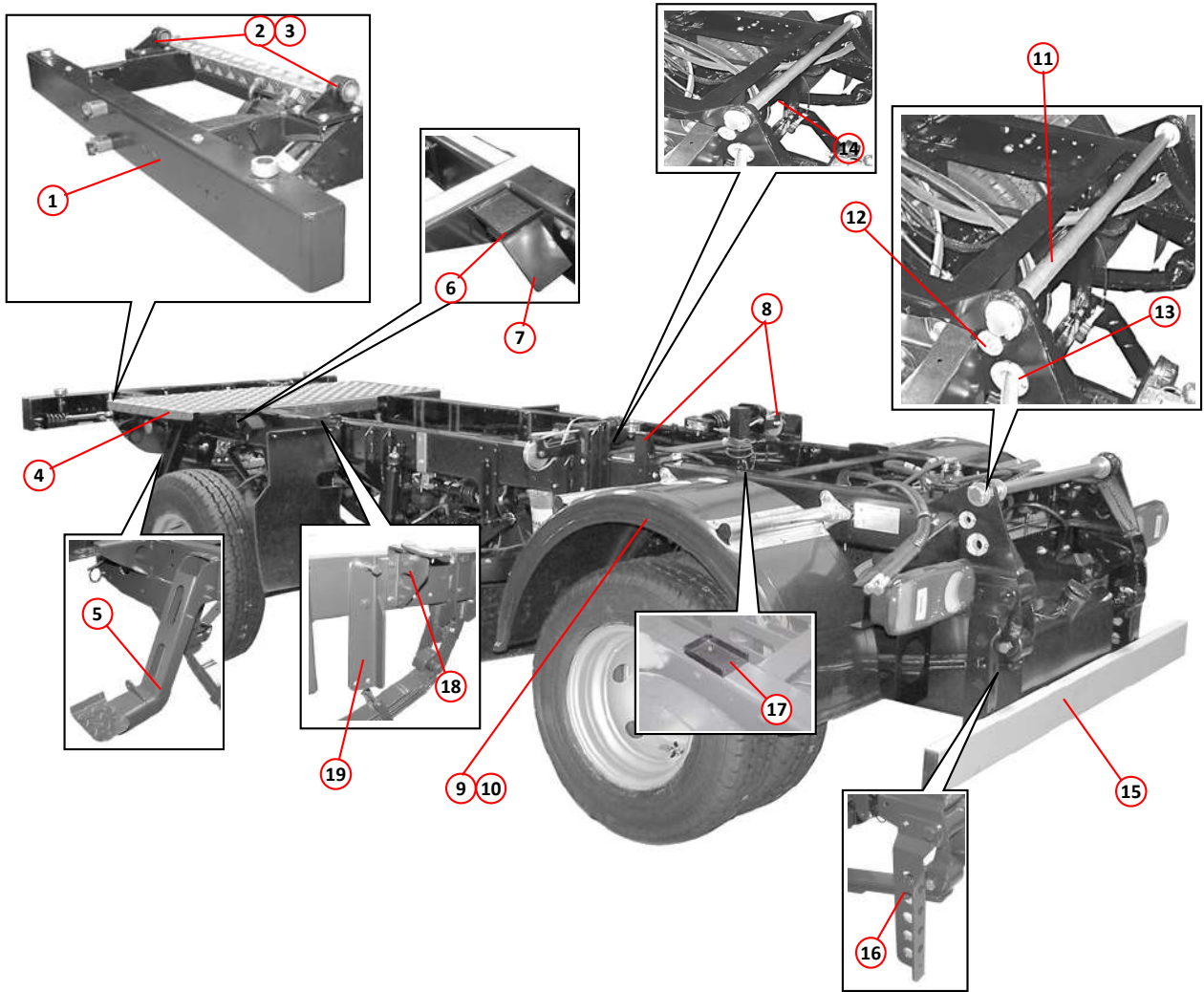

CHASSIS GENERAL ARRANGEMENT (DUAL SWEEP SHOWN)

Item	Part Number	Quantity	Description
Chassis General Arrangement - Continued			
20	013853	1	Bracket, wide sweep lift, LH/RH Page 112
	011011	4	. Setscrew, M8 x 25mm
	011073	4	. Nut, M8, Nyloc
21	033267	1	Cover, LH drive
NI	014398	1	Cover, RH drive
	011071	3	. Nut, M6 Nyloc
	010545	1	. Titanfast
	013426	1	. Screw, pan head, M8 x 20mm
	011073	10	. Nut, M8, Nyloc
22	021640	Pair	Chassis rail
23	011599	2	Hopper ram trunnions
	011031	8	. Setscrew, M10 x 25mm
	011075	8	. Nut, M10, Nyloc
24	034948	1	Cross member (rear front)
25	013418	1	Cross member (rear middle)
	011011	6	. Setscrew, M8 x 20mm
	011012	4	. Setscrew, M8 x 30mm
	011073	10	. Nut, M8, Nyloc
26	032035	1	Cross member (rear back) *
27	032038*	2	. Bracket
NI	032036*	1	. Bracket, LH
28	032037*	1	. Bracket, RH
	011012*	12	. . Setscrew, M8 x 30mm
	011013*	2	. . Setscrew, M8 x 35mm
	011010*	4	. . Setscrew, M8 x 20mm
	011073*	18	. . Nut, hex, M8 Nyloc
	011032*	1	. . Setscrew, M10 x 30mm
	011034*	1	. . Setscrew, M10 x 40mm
	011075*	2	. . Nut, M10, Nyloc
NI	014835	1	Cross member (front)
NI	013938	1	Label, load apportioning valve (LAV)
	011125	4	. Rivet, blind, 3.2mm x 10mm
29	013998**	1	Bracket, rear light cluster, LH
30	013999**	1	Bracket, rear light cluster, RH
31	012934**	1	Bracket, number plate
	011010	4	. Setscrew, hex head, M8 x 20mm
	011073	2	. Nut, M8, Nyloc
NI	033758	1	Bracket, steering box, RH Page 62, 68
NI	033759	1	Bracket, steering box, LH Page 62, 68
	011052	4	. Setscrew, M12 x 30mm
	011077	4	. Nut, M12, Nyloc
	011011	2	. Setscrew, M8 x 25mm
	011073	2	. Nut, M8, Nyloc
32	032655	1	Tank, fuel (dual sweep vehicles only) Page 22
NI	032654	1	Tank, fuel (single sweep vehicles only) Page 22
NI	031244	1	Cover, fuel tank (dual sweep vehicles only)
NI	024106	1	. Clamp, fuel tank cover, Inner
NI	024107	1	. Clamp, fuel tank cover, outer
	011011	2	. Setscrew, hex head, M8 x 25mm
	011073	2	. Nut, M8, Nyloc

Notes:-

* Rear cross member kit - Order Part No. 032039 .

** For machines built after April 2013 see Page 48.

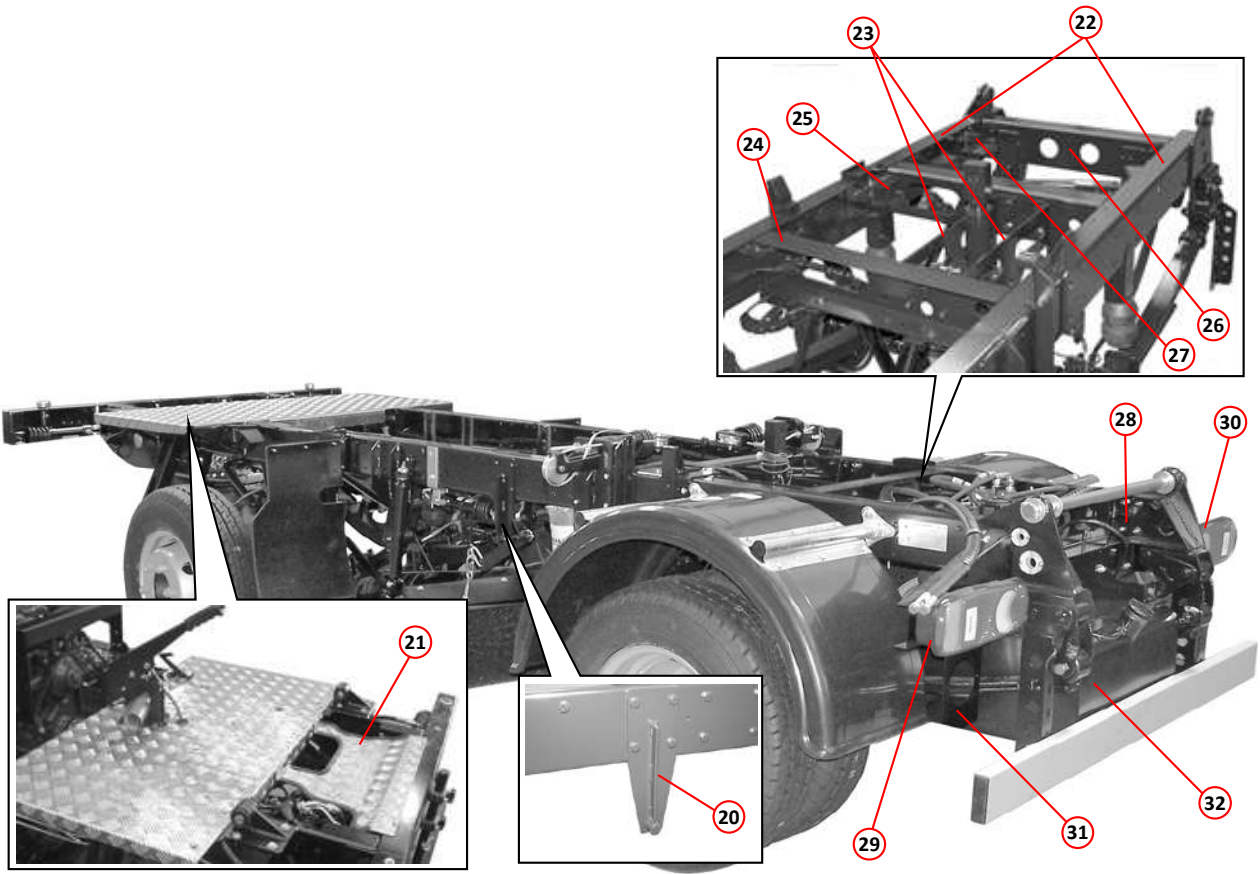

CHASSIS GENERAL ARRANGEMENT (DUAL SWEEP SHOWN)

<i>Item</i>	<i>Part Number</i>	<i>Quantity</i>	<i>Description</i>
Chassis General Arrangement - Continued			
33	032627	1	Bracket, hopper raise sensor
34	039762	1	Bracket, hopper raise sensor, alternate, (Not Hi-Tip models)
35	032627	1	. Hopper raise sensor Page 223
36	039374	1	. Mounting bracket for Node 08, Compact Module CR2031
37	040070	1	. . Cover, Node 08
38	038214	1	. . Node 08, Compact Module CR2031 Page 220
	000422	3	. . . Bolt, socket head, M5 x 25mm, black
39	014748	1	Brake load apportioning valve (LAV) Page 74

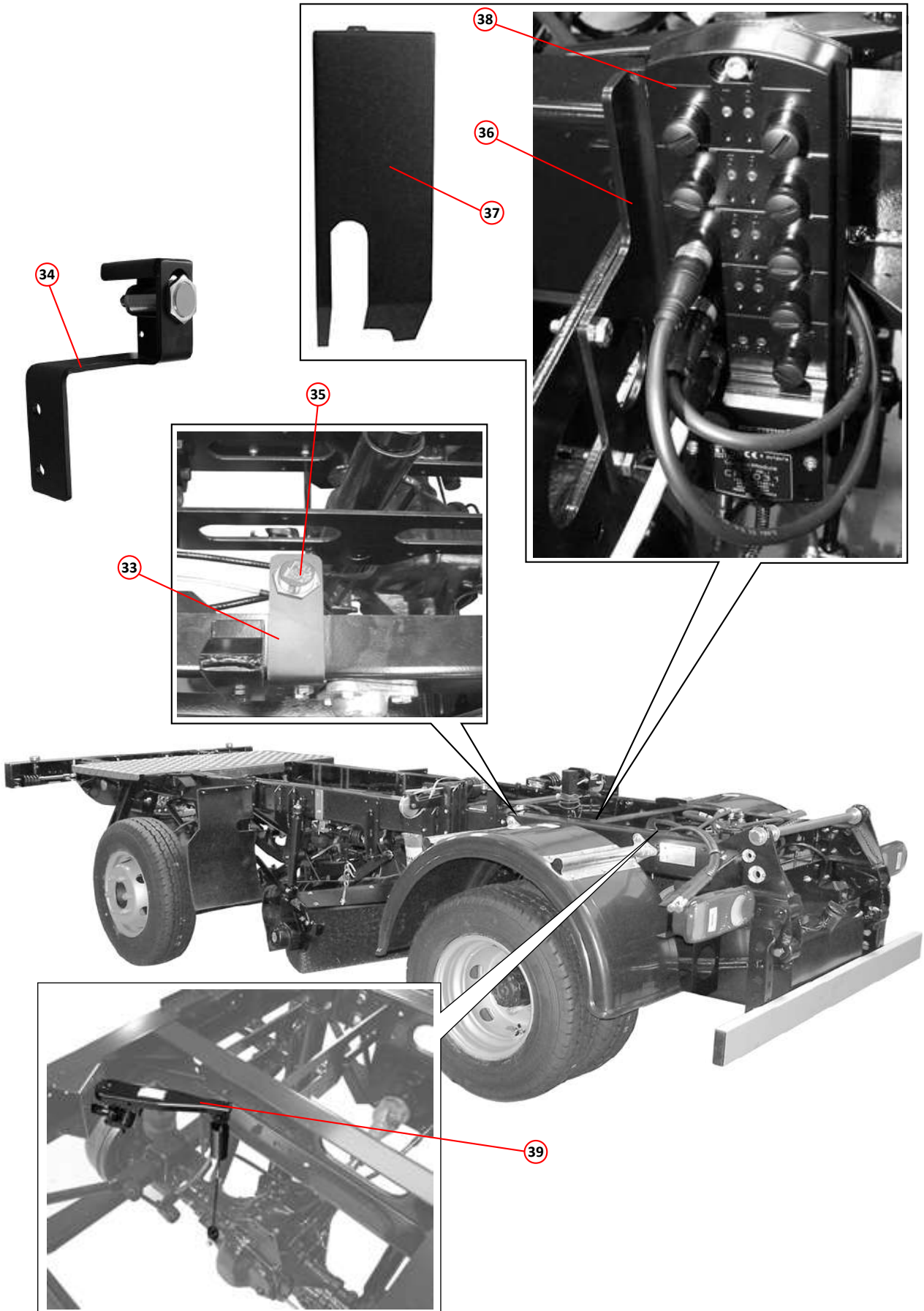

CHASSIS GENERAL ARRANGEMENT (DUAL SWEEP SHOWN)

<i>Item</i>	<i>Part Number</i>	<i>Quantity</i>	<i>Description</i>
Rear Lights, Bumper and Brackets (April 2013 - on)			
1	039955	1	Bracket, rear light and bumper, LH
NI		1	Bracket, rear light, left hand (1.6 Hi-Tip) Page 144
2	038560	1	Rear light cluster, LH Page 224
3	037246	1	Number plate bracket
4	039956	1	Bracket, light and bumper, RH
5	038561	1	Rear light cluster, RH Page 224
NI		1	Bracket, rear light, right hand (1.6 Hi-Tip) Page 144
6	038678	2	Reversing light
7	028786	1	Bumper, under run
NI	028785	2	. End cap, rear bumper
	011414	2	. . Coach bolt, M8 x 30mm
	011092	2	. . Washer, M8
	011073	2	. . Nut, M8, Nyloc
	005075	AR	. Double sided tape
NI	004544	2	Tail light bulb, 12V 10W SE245 Page 224

<i>Item</i>	<i>Part Number</i>	<i>Quantity</i>	<i>Description</i>
Bumper Conversion (April 2013 - on)			
1	041490	1	Bracket, rear light and bumper, LH
2	041492	1	. Number plate support bracket
3	041493	1	. . Number plate lamp
NI	011484	1	. . . Number plate bulb
	000133	2	. . Bolt, M4 x 40mm
	000309	2	. . Washer M4
	000134	2	. . Nut, M4
NI	004193	AR	. . . Twin core cable
NI	004201	2	. . . Pozi lock terminal
NI	004202	2	. . . Pozi lock cover
4	041491	1	Bracket, rear light and bumper, RH

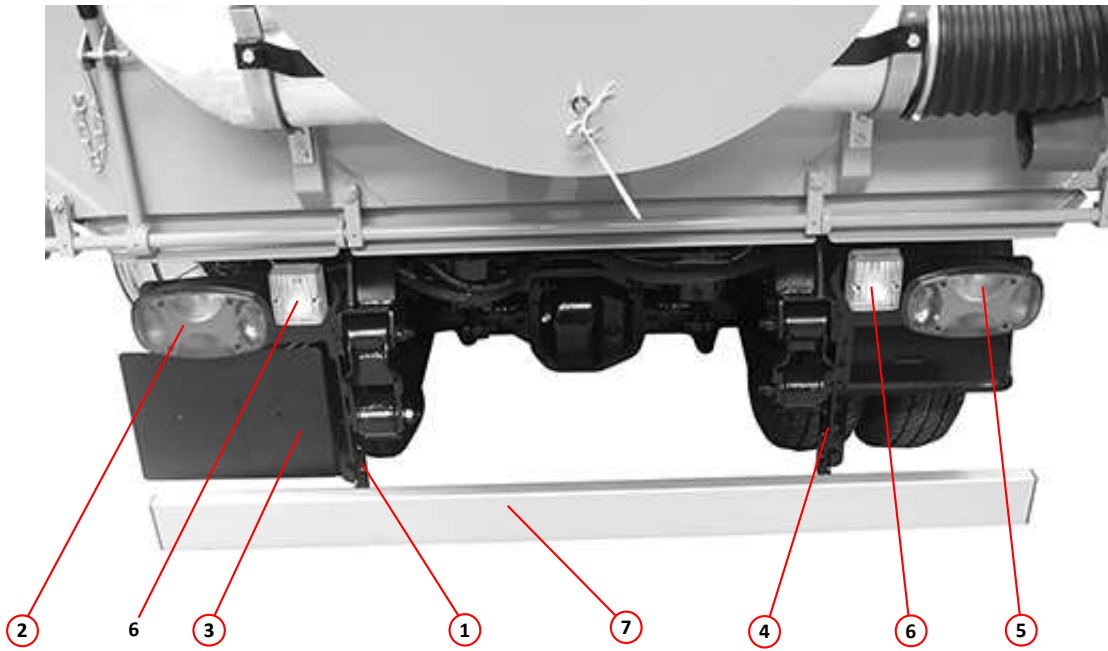

REAR LIGHTS, BUMPER AND BRACKETS (APRIL 2013 - ON)

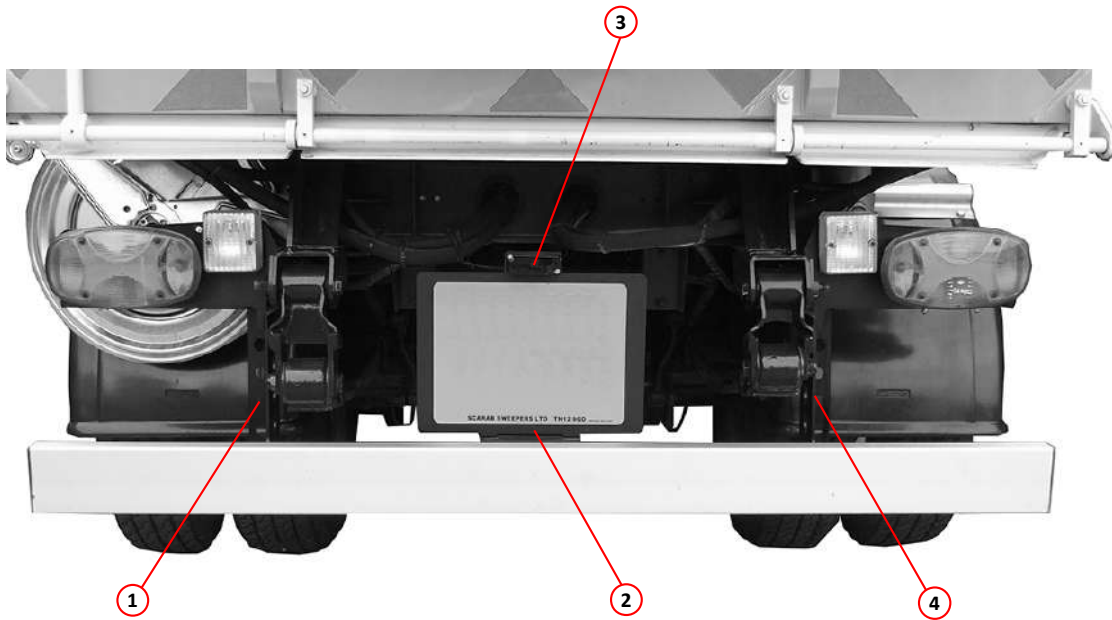

BUMPER CONVERSION (APRIL 2013 - ON)

<i>Item</i>	<i>Part Number</i>	<i>Quantity</i>	<i>Description</i>
Gantry General Arrangement			
1	033760	1	Gantry frame LH leg
2	037144	1	Gantry frame RH leg
	011031	8	. Setscrew, M10 x 25mm
	036454	8	. Safety washer, Schnorr
	027156	8	. Spacer, hex, M10
3	038889	1	. Gantry shelf
	011031	7	. . Setscrew, M10 x 25mm
	011095	7	. . Washer, spring, M10
	011074	7	. . Washer, M10
	011075	7	. . Nut, M10, Nyloc
4	038212	1	. . Earth strip frame
	011067	2	. . . Setscrew, M6 x 25mm
	011090	4 Washer, M6
	011071	2 Nut, M6, Nyloc
5	038677	1	Oil tank assembly Page 194
6	037171	1	Radiator assembly Page 16, 192
7	037169	1	Battery 12 Volt 110 Ah
8	014834	1	Cab locking strap
	011011	4	. Setscrew, M8 x 25mm
	011073	4	. Nut, M8, Nyloc
9	021904	1	. Eye bolt, cab lock
	011029	1	. . Screw, socket cap head, M8 x 35mm
10	039583	1	Air cleaner assembly Page 20
11		1	. ECU enclosure Page 52
NI	027742	1	. Manifold oil tank feed Page 192
12	025148	1	. Manifold oil tank return Page 192
NI	026866	1	Water pump, electric Page 154
13		1	Valve block - brush control Page 182
14		1	Valve block - main control Page 180
15	026420	1	Bracket, mounting, LH extension panel, upper rear
	011067	1	. Setscrew, M6 x 25mm
	011090	4	. Washer, plain, M6
	011071	1	. Nut, M6, Nyloc
NI	023231	1	. Receiver (DZUS fastener)
16	026421	1	Bracket, mounting, L H extension panel, upper front
	011067	1	. Setscrew, M6 x 25mm
	011090	4	. Washer, M6
	011071	1	. Nut, M6, Nyloc
	026417	1	. Bolt (DZUS fastener)
	032229	1	. Washer (DZUS fastener)
	023231	1	. Receiver (DZUS fastener)
17	026949	1	Bracket, mounting, LH extension panel, lower front
	026417	4	. Bolt (DZUS fastener)
	023229	4	. Washer (DZUS fastener)
	023231	4	. Receiver (DZUS fastener)
18	026950	1	Bracket, mounting, LH extension panel, lower rear
	026417	1	. Bolt (DZUS fastener)
	023229	1	. Washer (DZUS fastener)
	023231	1	. Receiver (DZUS fastener)
19	037703	1	Radiator partition

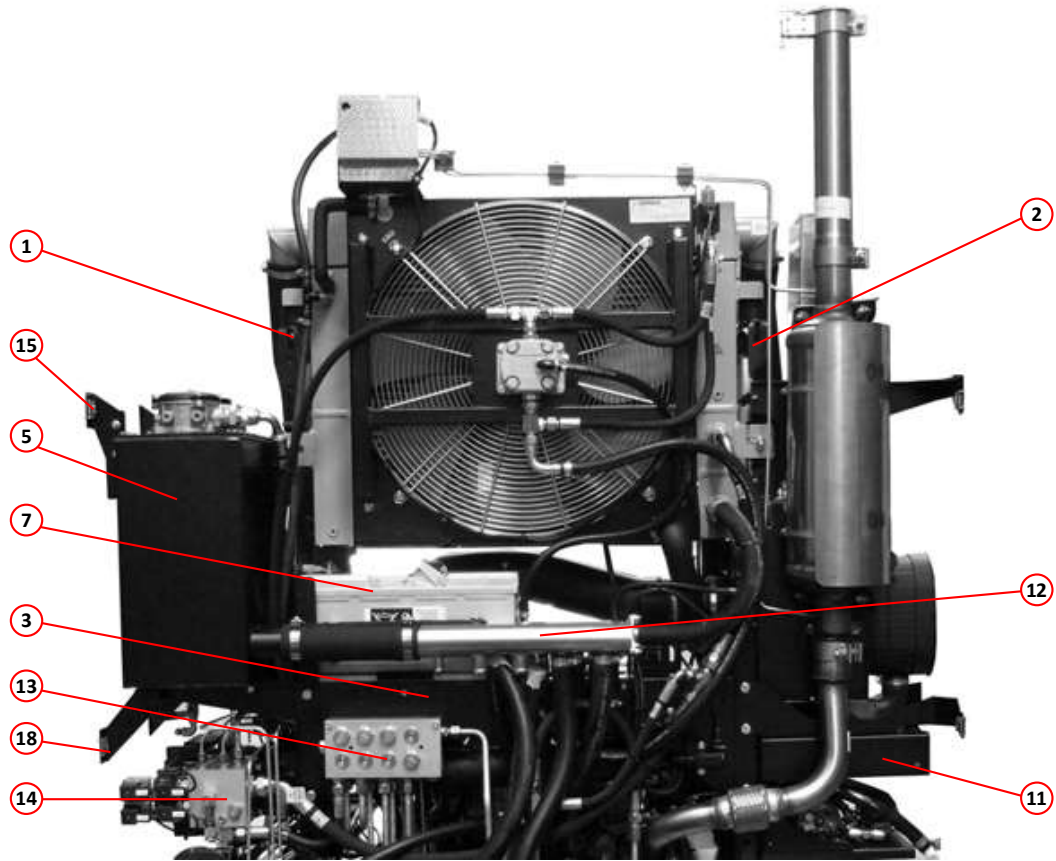

Viewed From The Rear

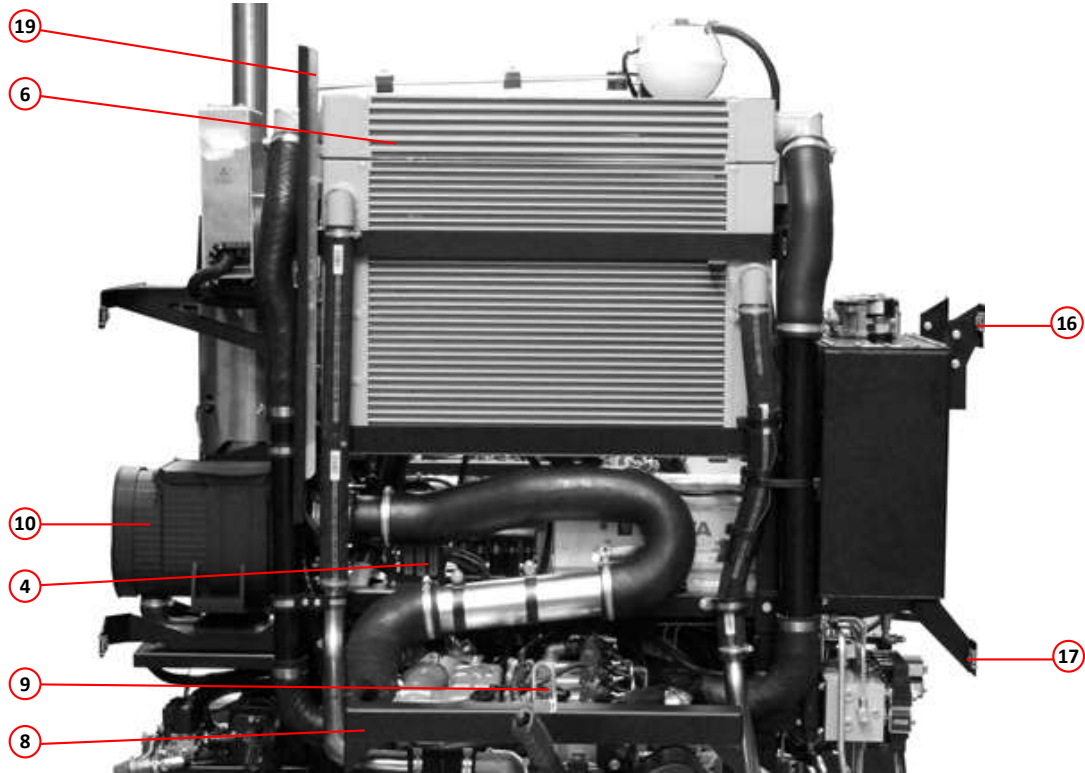

Viewed From The Front

GANTRY GENERAL ARRANGEMENT

Item	Part Number	Quantity	Description
Gantry General Arrangement - Continued			
20	037164	4	. Bracket, exhaust, upper
21	039163	1	. . Node 04 mounting bracket Page 220
	011010	4	. . . Setscrew, M8 x 20mm
	011093	4	. . . Washer, spring, M8
	011092	4	. . . Washer, M8
22	039164	1	. . Node 04 cover bracket Page 220
	011001	4	. . . Setscrew, M6 x 16mm
23	042336	1	. . Node 04, Mobile Controller CR0020 (programmed) Page 220,223
	000052	4	. . . Setscrew, M5 x 16mm
	000155	4	. . . Nut, M5, Nyloc
24	037160	1	. Water services, hanger plate Page 154
	011073	4	. . Nut, M8, Nyloc
NI	037161	1	. Bracket, water services, hanger plate, rear
	011075	2	. . Nut, M8, Nyloc
NI	037162	1	. Bracket, water services, hanger plate, front
	011075	2	. . Nut, M8, Nyloc
25	037157	1	. ECU housing
26	037159	1	. ECU shelf
27	037935*	1	. . ECU Page 223
	011087	4	. . . Setscrew, M6 x 25mm
	011090	4	. . . Washer, M6
28	037158	1	. Cover, ECU housing
	011075	2	. . Nut, M8, Nyloc
29	037153	1	. Bracket, mounting, RH extension panel, upper
	000105	4	. . Screw, socket cap head, M8 x 20mm
	011093	4	. . Washer, spring, M8
	026417	2	. . Bolt (DZUS fastener)
	023229	2	. . Washer (DZUS fastener)
	023231	2	. . Receiver (DZUS fastener)
30	037151	1	. Bracket, mounting, RH extension panel, lower front
	011030	1	. . Setscrew, M10 x 20mm
	036454	4	. . Washer, Schnorr safety, VS10
	011075	1	. . Nut, M10, Nyloc
	026417	1	. . Bolt (DZUS fastener)
	023229	1	. . Washer (DZUS fastener)
	023231	1	. . Receiver (DZUS fastener)
31	037152	1	. Bracket, mounting, RH extension panel, lower rear
	011030	1	. . Setscrew, M10 x 20mm
	036454	4	. . Washer, Schnorr safety, VS10
	011075	1	. . Nut, M10, Nyloc
	026417	1	. . Bolt (DZUS fastener)
	023229	1	. . Washer (DZUS fastener)
	023231	1	. . Receiver (DZUS fastener)
32	037150	1	. Bracket, air filter
	000105	4	. . Screw, socket cap head, M8 x 20mm
	011093	4	. . Washer, spring, M8
33	037165	1	. Bracket, exhaust, lower
	011010	3	. . Setscrew, M8 x 20mm
	011093	3	. . Washer, spring, M8
	011092	3	. . Washer, plain, M8
34	038885	1	. Mounting plate for Node 07, Compact Module CR2031
	011011	3	. . Setscrew, M8 x 25mm
	011092	3	. . . Washer, M8
35	04069	1	. . Cover, Node 07
36	038214	1	. . Node 07, Compact Module CR2031 Page 220, 223
	000422	3	. . . Bolt, socket head, M5 x 25mm, black

Notes:-

* The ECU must be matched to the engine by serial number.

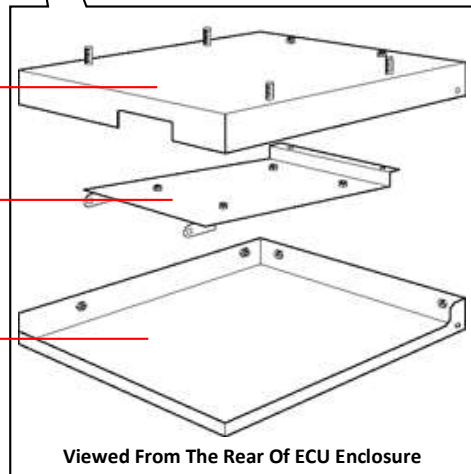
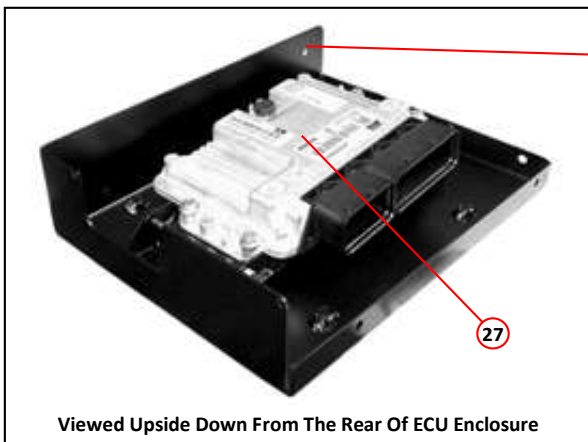
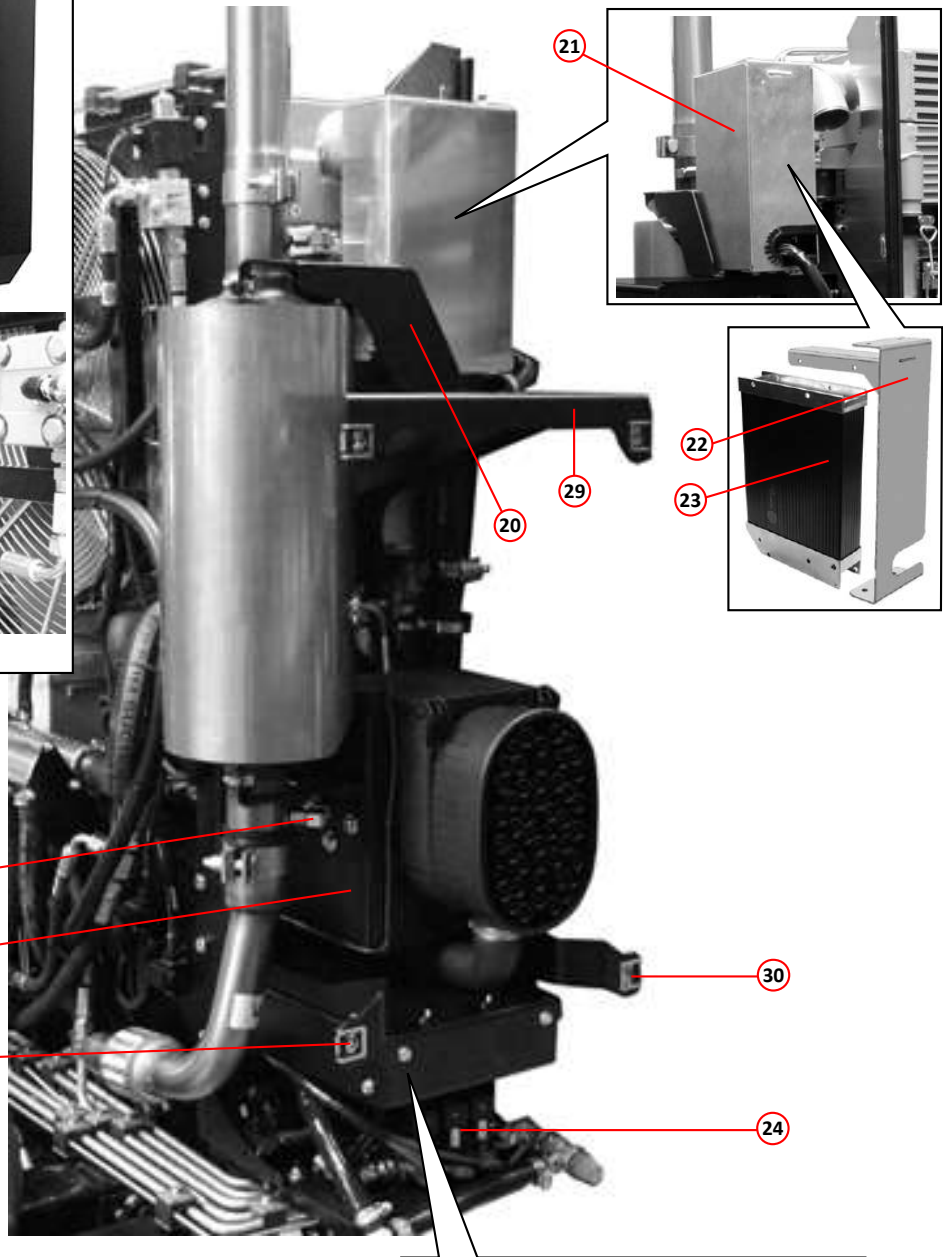
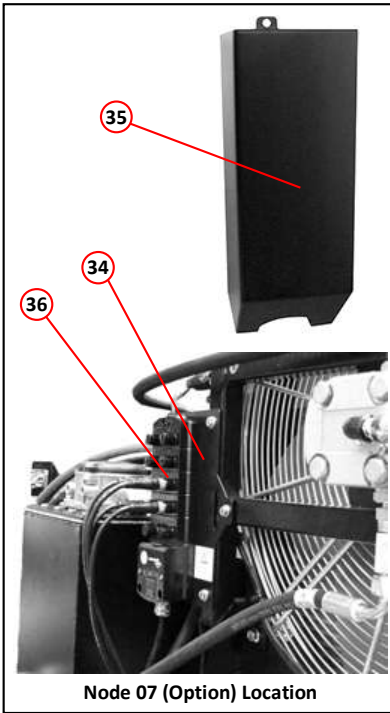

GANTRY GENERAL ARRANGEMENT

<i>Item</i>	<i>Part Number</i>	<i>Quantity</i>	<i>Description</i>
Front Mud Flap Assembly			
1	014745	2	Mud flap
2	014738	1	. Bracket, mud flap LH
3	014739	1	. Bracket, mud flap RH
4	026625	2	. Clamp strip, mud flap
	011001	6	. . Setscrew, M6 x 16mm
	011071	6	. . Nut, M6, Nyloc
	011091	6	. . Washer, spring, M6

<i>Item</i>	<i>Part Number</i>	<i>Quantity</i>	<i>Description</i>
Rear Mudguard Assembly			
1	013402	2	Mudguard (J22)
2	013404	4	. Bracket
3	014162	4	. Stay mudguard
4	012954	4	. Bracket back plate
	011010	24	. . Setscrew, M8 x 20mm
	011073	24	. . Nut, M8, Nyloc
5	011766	1	Suction tube blanking plate
6	010502	1	. Handle
7	023275	1	. Bracket
8	013506	2	. Pin, locating
9	013507	2	. Linchpin and chain

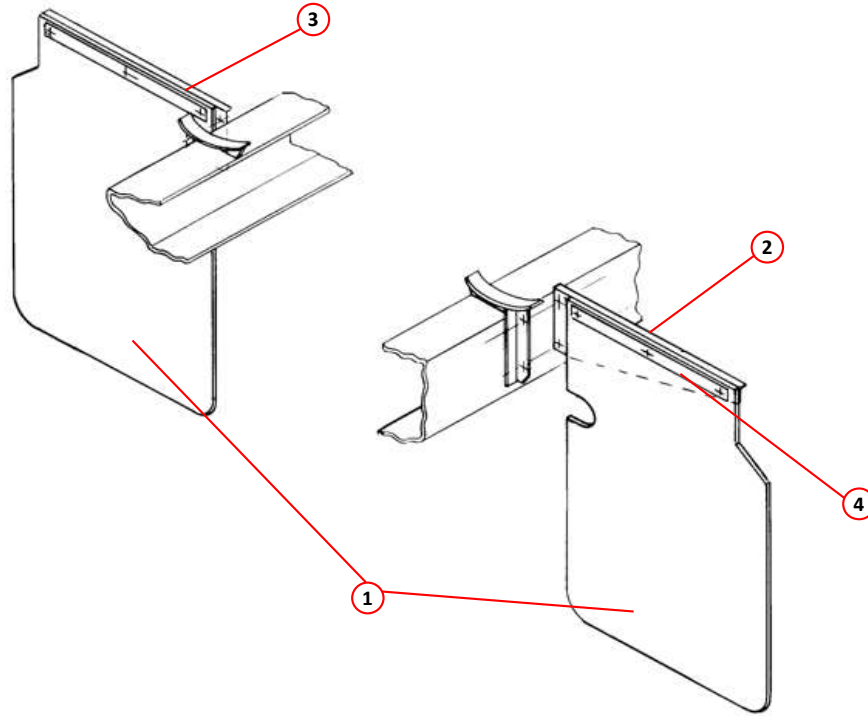

FRONT MUD FLAP ASSEMBLY

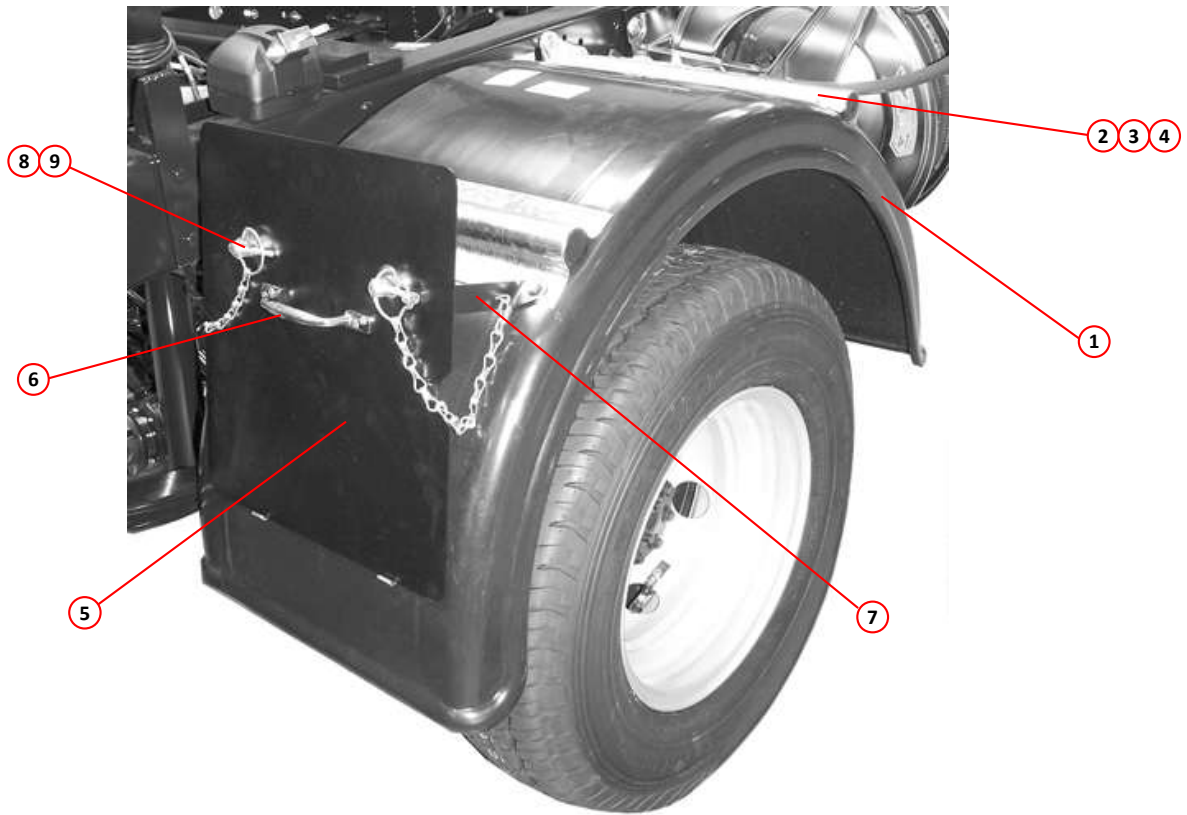

REAR MUDGUARD ASSEMBLY

<i>Item</i>	<i>Part Number</i>	<i>Quantity</i>	<i>Description</i>
Front Suspension Assembly			
1	037041	2	Leaf spring, front
NI	023627	4	. Spring bush (before November 2012)
NI	037221	4	. Poly bush kit (from November 2012)
	011419	4	. . Bolt, M14 x 110mm
	011127	4	. . Nut, M14
NI	100013	2	. Bush,
2	013849	4	. Shackle, front spring
	034244	4	. . Bolt, M12 x 110mm
	011077	4	. . Nut, M12
3	027671	2	. Clamp, stabiliser bar
4	027670	2	. Clamp bush, rubber
	011073	4	. . Setscrew, M8 x 25mm
	011092	4	. . Washer, M8
	011073	4	. . Nut, M8
5	027668	1	. Stabiliser bar
6	100134	2	. Drop link
	011077	4	. . Nut, M12
7	100035	2	. Shock absorber
	011055	2	. . Bolt, M12 x 65mm
	011096	6	. . Washer, M12
	011077	4	. . Nut, M12
8	014639	2	. Top plate
NI	023343	1	. Packer (fitted to near- side only)
	000162	4	. . Bolt, M14 x 110mm (used without packer)
	000163	4	. . Bolt, M14 x 120mm (used with packer)
	000164	8	. . Nut, M14
	000315	1	. . Screw, socket cap head, M10 x 90mm (leaf spring centre near-side only)
9	013755	2	. Rubber Aeon hollow spring
	011053	2	. . Setscrew, M12 x 35mm
	011077	2	. . Nut, M12
10		1	. . Axle beam Page 60, 64

<i>Item</i>	<i>Part Number</i>	<i>Quantity</i>	<i>Description</i>
Rear Suspension Assembly			
1		1	Axle assembly, rear Page 32
2	037040	2	Leaf spring, rear
NI	038451	2	. Spring bush, front eye (before November 2012)
NI	040037	2	. Poly bush kit, front eye (from November 2012)
NI	038452	2	. Spring bush, rear eye (before November 2012)
NI	040038	2	. Poly bush kit, rear eye (from November 2012)
	011133	2	. . Bolt, M16 x 100mm (spring to shackle)
	011060	2	. . Nut, M16
	011422	2	. . Bolt, hex head, M20 x 110mm (spring to chassis)
	011082	2	. . Nut, M20
3	100029	2	. Shackle (RH drive vehicles)
NI	023345	1	. Shackle (replaces 100029 nearside on LH drive vehicles)
4	027669	1	. Stabiliser bar
5	027671	2	. . Clamp, stabiliser bar
6	027670	2	. . Clamp bush, rubber
	011073	4	. . Setscrew, M8 x 25mm
	011092	4	. . Washer, M8
	011073	4	. . Nut, M8
7	100035	2	. Shock absorber
	011055	2	. . Bolt, M12 x 65mm
	011077	4	. . Nut, M12
8	020657	2	. Axle packer
9	034005	2	. Packer shim
10	100025	4	. U-Bolt
	011135	8	. . Washer, M16
	011060	8	. . Nut, M16
11	100134	2	. Drop link
	011077	4	. . Nut, M12
12	013755	2	. Bump stop
	011053	2	. . Setscrew, M12 x 35mm
13	024064	1	Load sensor, wobble switch (option) Page 223
14	033672	1	. Bracket, load sensor, (on chassis)
15	035610	1	. Adjustable bracket
16	039421	1	. . Bracket, mounting, for adjustable bracket (on axle)
	000155	2	. . . Nut, M6, Nyloc
	000021	2	. . . Setscrew, high tensile, M6 x 40mm
	011073	2	. . . Nut, M8, Nyloc
17	024065	1	. Cable gland
NI	031649	1	. Wiring loom, load indicator
18	034691	4	Road wheel complete with tyre
	034690	4	. Road wheel
	013463	4	. . Tyre 195R x 14C
NI	041303	2	. . Wheel spacer
NI	041599	6	. . Wheel nut, Left hand thread, 18mm
NI	041600	6	. . Wheel nut, Right hand thread, 18mm
19	020315	2	. . Flex valve extension (complete)
	028809	4	. . Dust cap
20	039416	1	. Bracket, LAV lower mount

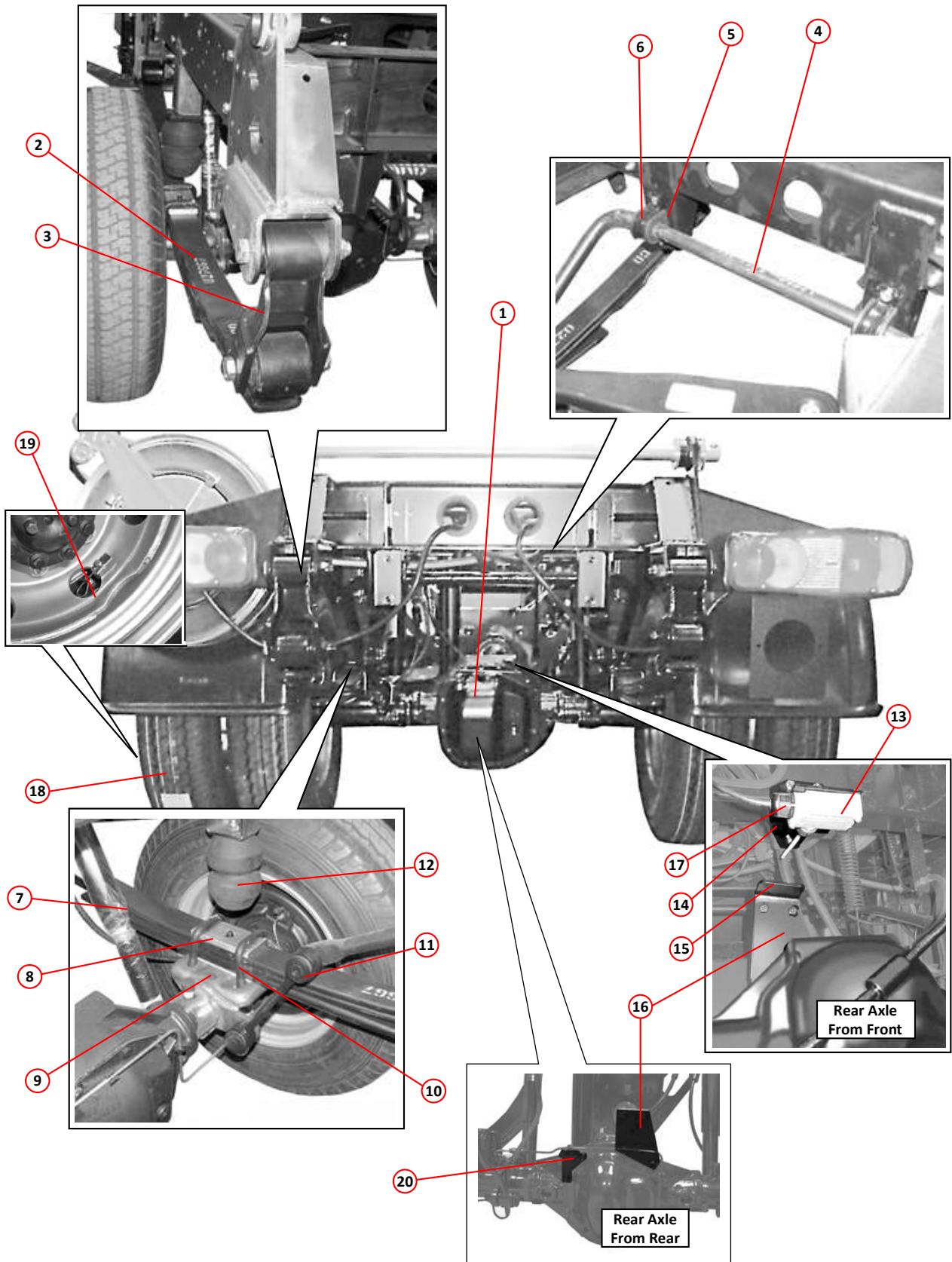

REAR SUSPENSION & ASSOCIATED PARTS

Item	Part Number	Quantity	Description
Front Axle Steering/Hub Arrangement			
LHD from June 2011, RHD from August 2013			
1	038616	1	. Axle beam (2T)
2	038618	1	. Stub axle RH (2T)
3	038617	1	. Stub axle LH (2T)
4	038624*	2	. . King pin (2T)
5	038625*	2	. . . Cotter pin (2T)
	011406*	1 Washer, $\frac{3}{8}$ " HP S/Coil
	000032*	1 Nut, $\frac{3}{8}$ " UNF
6	038623*	4	. . . Bush, king pin (2T)
NI	040422*	2	. . . Thrust shim (2T) 0.004"
NI	040419*	2	. . . Thrust washer (2T) 0.113"
NI	040421	2	. . . Thrust washer (2T) 0.129"
	021634	AR Shim 0.046 - 0.050
	021635	AR Shim 0.051 - 0.055
	021636	AR Shim 0.056 - 0.060
	021637	AR Shim 0.061 - 0.065
	021638	AR Shim 0.036 - 0.042
	021639	AR Shim 0.066 - 0.070
			} Use as required
7	038626*	2	. . . Bush, upper, stub axle (2T)
8	038627*	2	. . . Bush, lower, stub axle (2T)
9	038648*	4	. . . Cover, king pin (2T)
10	038650*	4	. . . Washer, greasing point (2T)
11	038649*	4	. . . Greasing point (2T)
12	014592	1	. Hub assembly LH
13	014593	1	. Hub assembly RH
14	014594	2	. . Disc front
15	014627	10	. . . Stud (hub to disc)
	014595	10	. . . Nut (hub to disc)
	014596	10	. . . Lock washer (Hub to disc)
16	SCAKIT014601	1	. . Brake calliper assembly LH Page 76
17	SCAKIT014602	1	. . Brake calliper assembly RH Page 76
18	041061	2	. . Grease cap
19	014626	2	. . Oil seal
20	039759	2	. . Locking hub nut
	014768	2	. . . Washer, axle D
	021643	2	. . . Split pin $\frac{1}{8}$ " x $1\frac{1}{2}$ "
21	014597	6	. . Wheel stud front LH
NI	028807	6	. . . Wheel nut front LH
22	014598	6	. . Wheel stud front RH
NI	028808	6	. . . Wheel nut front RH
NI	034690	2	. . Road wheel
NI	034691	2	. . Road wheel complete with tyre
23	000425	2	. . Screw, socket button head, M10 x 50mm, plated
	011074	2	. . . Nut, M10
24	038621	1	Track rod (2T) Page 62
25	038622	2	Track rod arm (2T) Page 62
26	028180	1	Ball joint, track rod end, RH thread
27	028186	1	Ball joint, track rod end, LH thread
28	038619	1	Steering arm LHD (2T) Page 62
NI	038620	1	Steering arm RHD (2T) Page 62
NI	014619	2	Front hub bearing kit
NI	041656*	1	Front axle king pin kit (2T)

Notes:-
 * The kit contains the marked components for one side only.

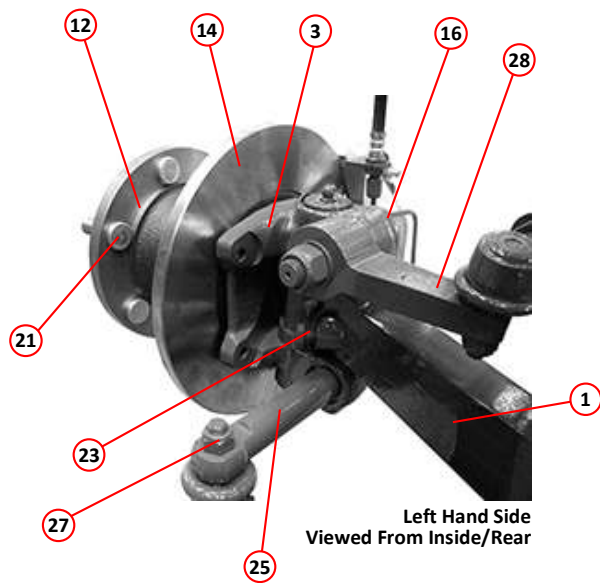
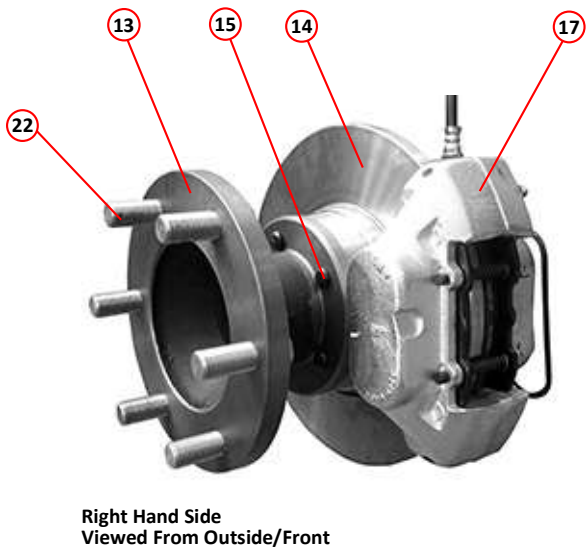
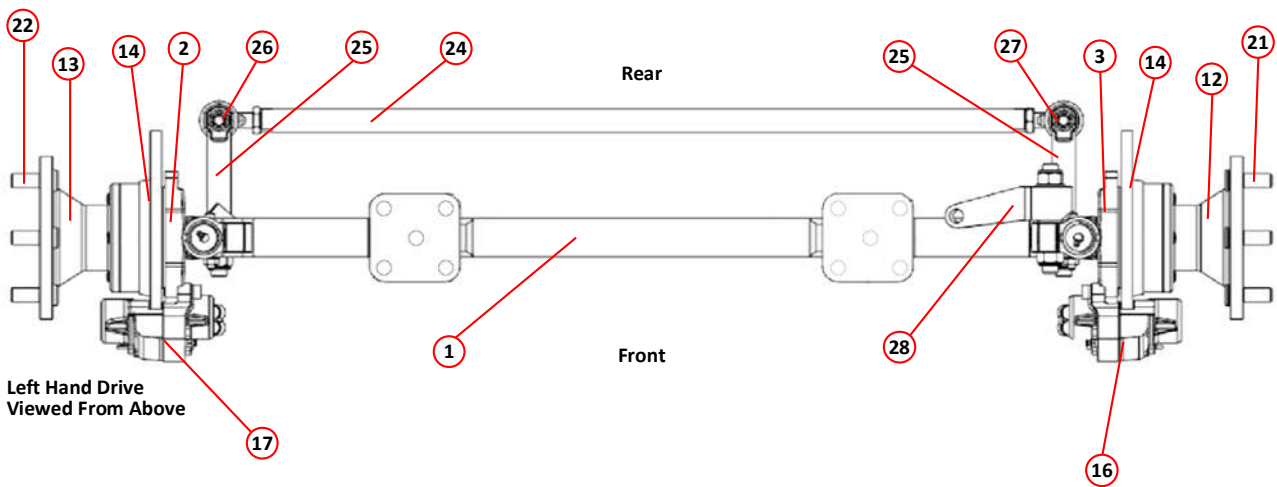
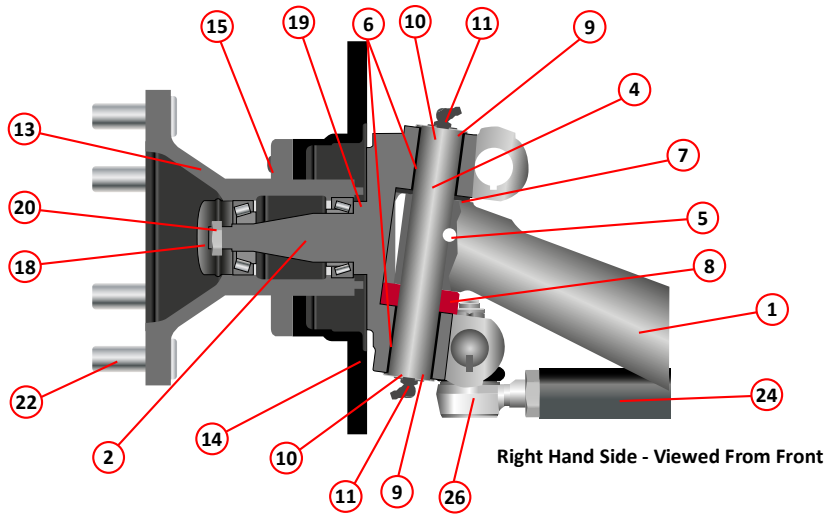

FRONT AXLE (STEERING AND HUBS)

Item	Part Number	Quantity	Description
Steering Arrangement *			
LHD from June 2011, RHD from August 2013			
1	033056	1	Steering box, LH drive vehicles
2	033759	1	. Bracket, mounting, steering box, LH
3	033861	1	. Support, steering box, LH
NI	033057	1	. Steering box, right hand drive
NI	033758	1	. Bracket, mounting, steering box, RH
NI	033862	1	. Support, steering box, RH
4	033058	2	. Drop arm
5	028187	2	. Drag link (complete with ball joints)
6	028186	2	. Ball joint, front, left hand thread (drop link end)
	031926	2	. Nut, ball joint locking, left hand thread
	031925	AR	. Washer, locking
7	028180	2	. Ball joint, rear, right hand thread (steering arm end)
	031924	2	. Nut, ball joint locking, left hand thread
	031925	AR	. Washer, locking
8	038619	1	. Steering arm LHD (2T)
NI	038620	1	. Steering arm RHD (2T)
	021628	1	. . Key, Woodruff
	038541	2	. . Nut, $\frac{5}{8}$ " UNF, Nyloc
	032696	1	. . Washer, special
9	038621	1	. Track rod (2T)
10	028180	1	. Ball joint, right hand thread (right hand front wheel side)
11	028186	1	. Ball joint, left hand thread (left hand front wheel side)
12	038622	2	Track rod arm (2T)
NI	021628	2	. . Key, Woodruff
	021629	2	. . Nut, $\frac{5}{8}$ " UNF

Notes:-

* For details relating to the steering wheel and column, please refer to Page 92

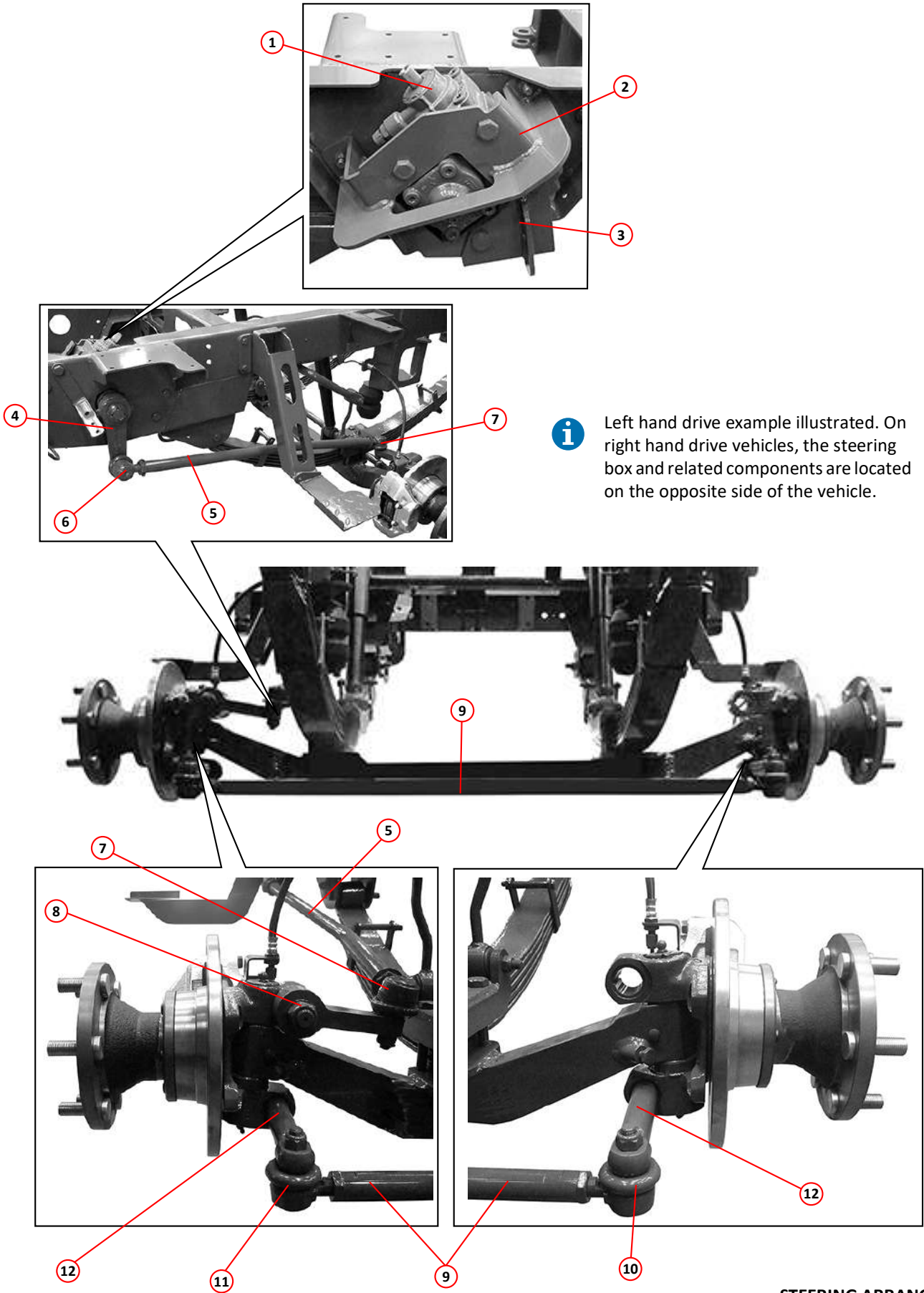

STEERING ARRANGEMENT

Item	Part Number	Quantity	Description
Front Axle Steering/Hub Arrangement			
LHD Pre June 2011, RHD Pre August 2013			
1	021611	1	Axle beam, LH Drive
1	038616*	1	Axle beam, RH Drive
2	034673	1	. Stub axle, RH
NI	034672	1	. Stub axle, LH
2	038618*	1	. Stub axle RH
NI	038617	1	. Stub axle LH
3	021620	2	. . Swivel pin
3	038624*	2	. . Swivel pin
	021631	4	. . Circlip
4	021616	4	. . Bearing, needle roller
4	038623*	4	. . Swivel pin bush
5	036773	2	. . Plate, lower wear
6	036772	2	. . Bearing, thrust plate
7	036774	2	. . Plate, upper wear
7	038627*	2	. . Bearing, thrust complete
NI	036775	2	. . Bearing, thrust plate kit
8	021633	4	. . . O-ring
9	021610	4	. . . End cap
9	038648*	4	. . . End cap
10	021632	4	. . . Greasing point, $\frac{1}{4}$ " UNF
10	038650*	2	. . . Greasing point
NI	038650	2 Greasing point washer
11	021622	2	. . . Cotter pin
11	038625*	2	. . . Cotter pin
	021627	2 Spring washer
	021626	2 Nut, hex, $\frac{5}{16}$ " UNF
12	021634	AR Shim 0.046 - 0.050
	021635	AR Shim 0.051 - 0.055
	021636	AR Shim 0.056 - 0.060
	021637	AR Shim 0.061 - 0.065
	021638	AR Shim 0.036 - 0.042
	021639	AR Shim 0.066 - 0.070
12	038626*	2 Shim
	021842	1	Swivel pin repair kit comprising of items 3 to 10 (RH drive only)
NI		1	. Steering box Page 68
13	014592	1	. Hub assembly LH
14	014593	1	. Hub assembly RH
15	014594	2	. . Disc front
	014627	10	. . . Stud (hub to disc)
	014595	10	. . . Nut (hub to disc)
	014596	10	. . . Lock washer (Hub to Disc)
16	021671	2	. . Brake disc shield
	011098	4	. . . Washer, spring, $\frac{1}{4}$ "
	000063	4	. . . Bolt, $\frac{1}{4}$ " UNF x $\frac{1}{2}$ "
17	014601	1	. . Brake calliper assembly LH Page 76
NI	014602	1	. . Brake calliper assembly RH Page 76
18	011014	2	. . Screw, socket button head M8 x 40mm
	011072	2	. . . Nut, M8

Use as required to achieve a clearance of 0.02mm to 0.08mm

Stop adjuster

Notes:-
* LH Drive vehicles only

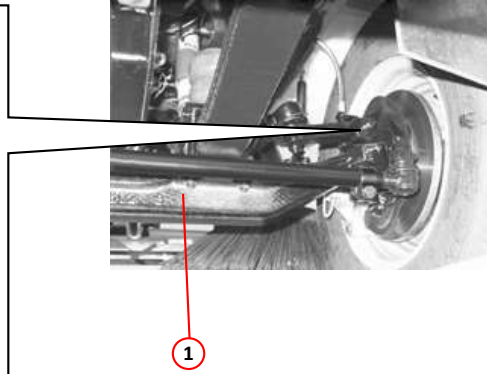
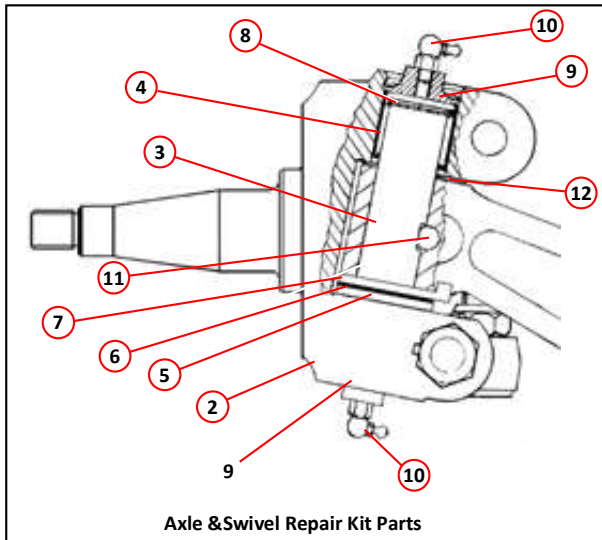

Axle & Swivel Repair Kit Parts

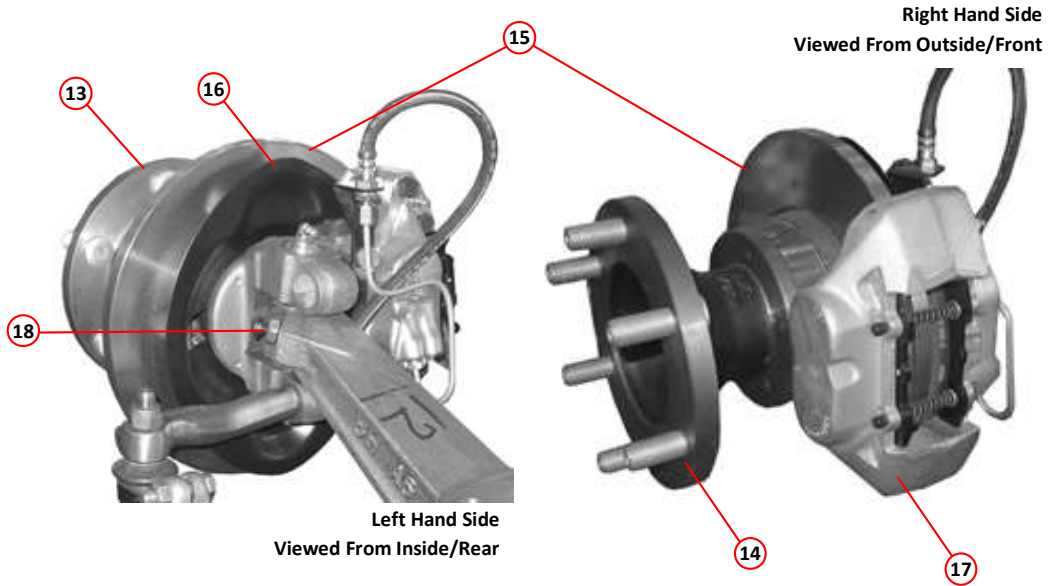

FRONT AXLE STEERING/HUB ARRANGEMENT

<i>Item</i>	<i>Part Number</i>	<i>Quantity</i>	<i>Description</i>
Front Axle Steering/Hub Arrangement - Continued			
LHD Pre June 2011, RHD Pre August 2013			
19	041061	2	. . Grease cap
20	014626	2	. . Oil seal
21	039759	2	. . Locking hub nut
	014768	2	. . . Washer, axle D
	021643	2	. . . Split pin $\frac{1}{8}$ " x $1\frac{1}{2}$ "
NI	014619	2	Front hub bearing kit
22	014597	6	. . Wheel stud front LH
	028807	6	. . . Nut (per road wheel) 27mm A/F, left hand thread
NI	014598	6	. . Wheel stud front RH
	028808	6	. . . Nut (per road wheel) 27mm A/F, right hand thread
NI	034690	2	. . Road wheel
NI	034691	2	. . Road wheel complete with tyre
NI	014819	2	. . . Hub cover

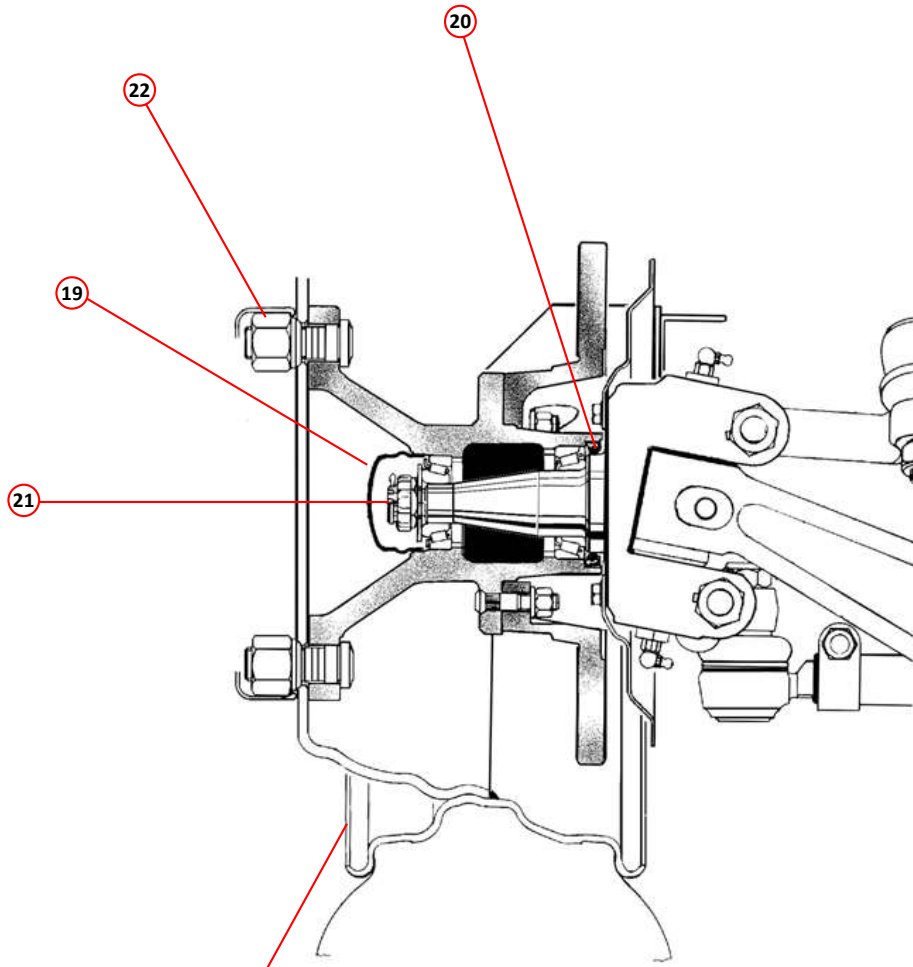

Road Wheel and Tyre

FRONT AXLE (STEERING)

Item	Part Number	Quantity	Description
Steering Arrangement *			
LHD Pre June 2011, RHD Pre August 2013			
1	033056	1	Steering box, LH drive vehicles
2	033759	1	. Bracket, mounting, steering box, LH
3	033861	1	. Support, steering box, LH
NI	033057	1	. Steering box, right hand drive (TWR)
NI	033758	1	. Bracket, mounting, steering box, RH
NI	033862	1	. Support, steering box, RH
4	033058	2	. Drop arm
5	028187	2	. Drag link (complete with ball joints)
6	028186	2	. Ball joint, front, left hand thread (drop link end)
	031926	2	. Nut, ball joint locking, left hand thread
	031925	AR	. Washer, locking
7	028180	2	. Ball joint, rear, right hand thread (steering arm end)
	031924	2	. Nut, ball joint locking, left hand thread
	031925	AR	. Washer, locking
8	038619	1	. Steering arm assembly
	021628	1	. . Key, Woodruff
	038541	2	. . Nut, $\frac{5}{8}$ " UNF, Nyloc
	032696	1	. . Washer, special
NI	035842	1	. Steering arm assembly, right hand drive
	021628	1	. . Key, Woodruff
	038541	2	. . Nut, $\frac{5}{8}$ " UNF, Nyloc
	032696	2	. . Washer, special
9	038622	2	. Track rod
10	028180	2	. Ball joint, right hand thread (right hand front wheel side)
11	028186	2	. Ball joint, left hand thread (left hand front wheel side)
12	021644	4	. Clamp, track rod end
	000249	2	. . Screw, socket cap head, M10 x 40mm
	011074	2	. . Nut, M10
13	022854	2	. Arm, track rod, RH
NI	021628	2	. . Key, Woodruff
	021629	2	. . Nut, $\frac{5}{8}$ " UNF
14	022855	2	Arm, track rod, LH
NI	021628	2	. . Key, Woodruff
	021629	2	. . Nut, $\frac{5}{8}$ " UNF

Notes:-

* For details relating to the steering wheel and column, please refer to Page 92

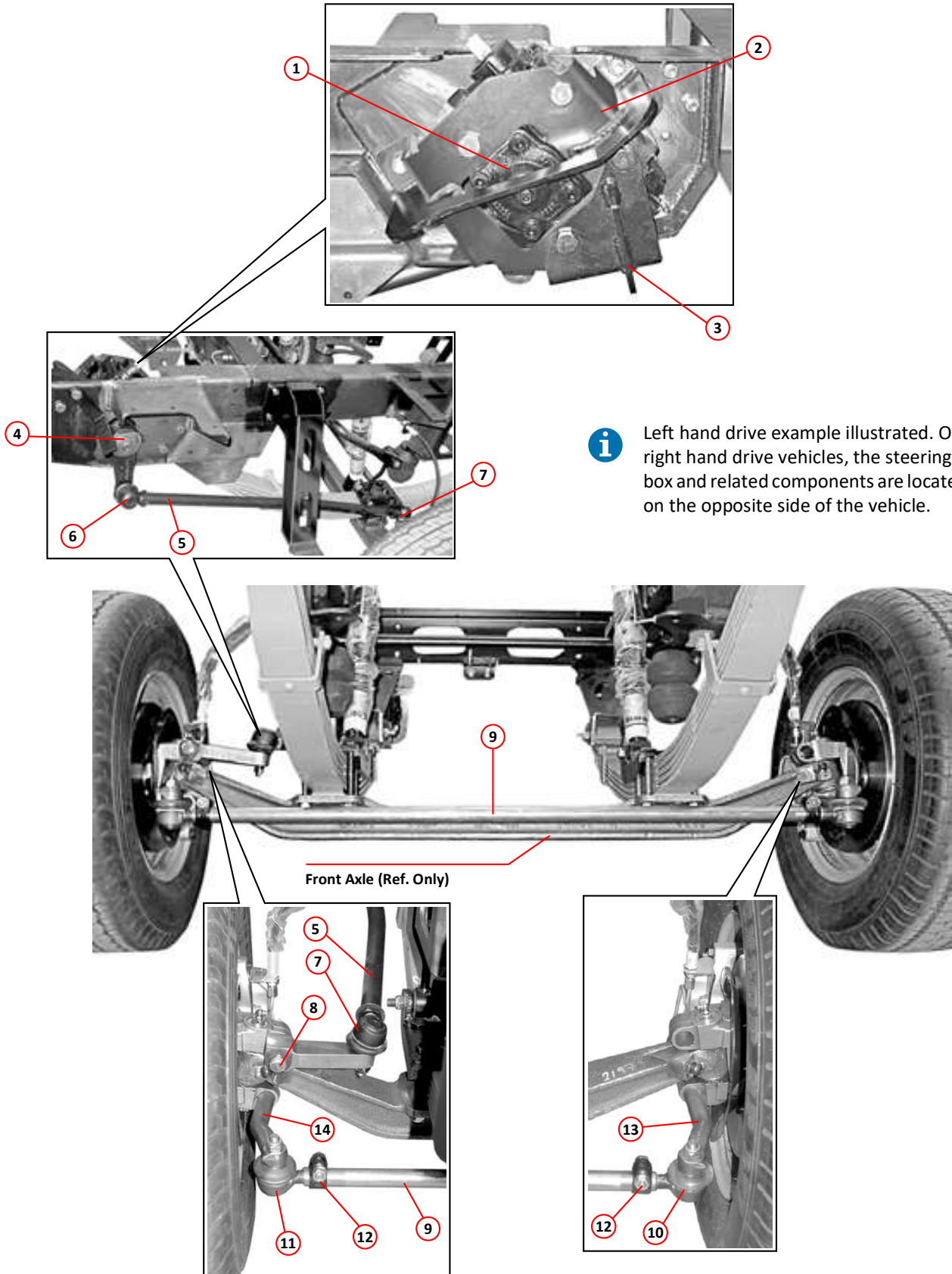

STEERING ARRANGEMENT

Item	Part Number	Quantity	Description
Teal Hand Wash Basin Assembly			
1	035948	1	Teal hand wash unit
2		1	Tank, part of item 1
	011001	4	. Bolt, M6 x 16mm
	011071	4	. Nut, M6, Nyloc
3	033112	1	. Bracket, tank, LH
4	033113	1	. Bracket, tank, RH
5	033268	1	. Adaptor, reducing, $\frac{3}{4}$ " UNF to $\frac{1}{4}$ " BSP female
6	010910	1	. . Elbow, galvanised, $\frac{1}{4}$ " BSP, M/F
7	003010	1	. . . Hose tail, $\frac{1}{4}$ " BSP x $\frac{3}{8}$ "
8	010950	AR Hose, black, $\frac{3}{8}$ " ID, Gripflex
9	010964	2 O-Clip, $\frac{9}{16}$ "
10	036168	1	. Cover, Teal tank
	011001	4	. . Setscrew, hex head, M6 x 16mm
11	023194	1	. Cover, hydraulic valve block
12	026417	4	. . Stud, turn-lock, Dzus
13	023229	4	. . . Stud retainer, Dzus
14	011094	4	. . . Washer, M10
NI	031838	1	. . Bracket, Teal cover, LH
	014025	2	. . . Spacer
NI	031839	1	. . Bracket, Teal cover, RH
	014025	2	. . . Spacer
NI	033237	2	. . Bracket, Teal cover, lower
15		1	. Basin and cover, part of item 1
16	033121	1	. Hinge, Teal basin and cover, RH
		1	. . Washer, white, part of item 1 - fits between hinge and cover
		1	. . Setscrew, hex head, M6 x 12mm, part of item 1
	011077	1	. . Nut, M12, Nyloc
NI	033123	1	. Hinge, Teal basin and cover, LH
		1	. . Washer, white, part of item 1 - fits between hinge and cover
		1	. . Setscrew, hex head, M6 x 12mm, part of item 1
	011077	1	. . Nut, M12, Nyloc
17	012253	1	. . Fastener, Antiluce
18	012969	1	. . . Washer, rubber
19	033124	1	. . . Bracket, mounting
20	010503	2	. . Fastener, wash basin, Gravelly
21		1	. Tap, part of item 1
NI	033269	1	. . Adaptor, reducing, $\frac{3}{4}$ " UNF to $\frac{1}{4}$ " BSP male
NI	010910	1	. . . Elbow, galvanised, $\frac{1}{4}$ " BSP, M/F
NI	003010	1 Hose tail, $\frac{1}{4}$ " BSP x $\frac{3}{8}$ " hose
NI	033120	1	. Wiring loom

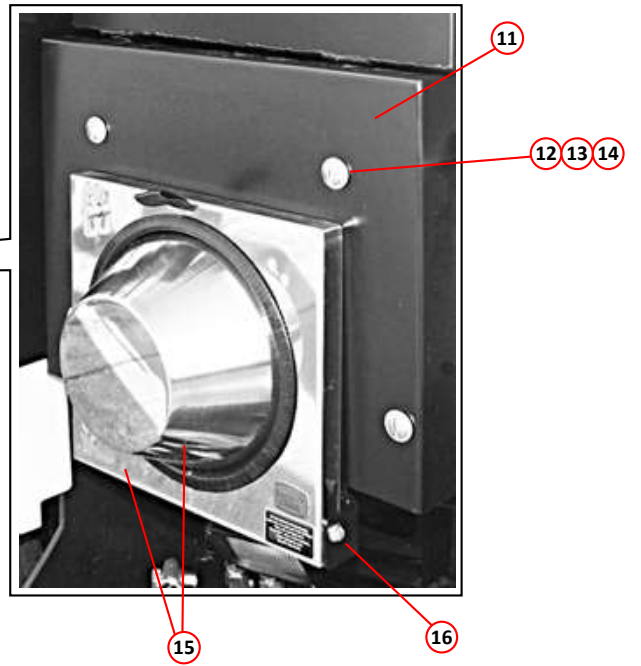
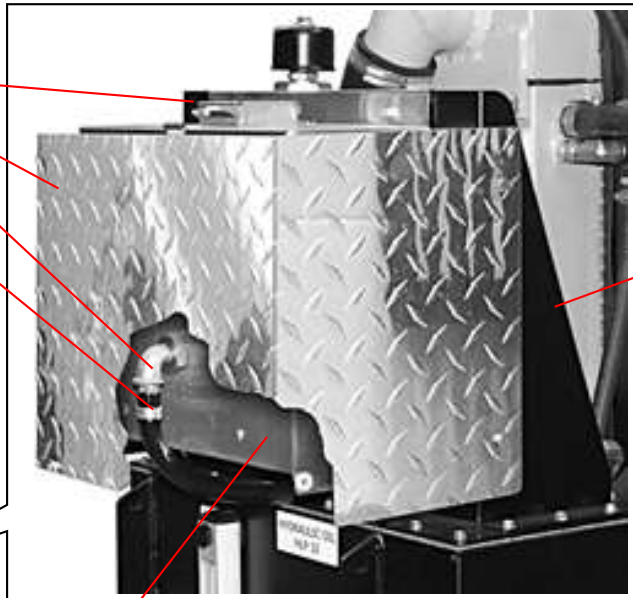

TEAL HANDWASH BASIN KIT

TEAL HAND WASH BASIN ASSEMBLY

Brakes and Related Equipment

<i>Assembly/Description</i>	<i>Page</i>
Braking System - General Arrangement	74
Brake Pedal Assembly	74
Front Brake Caliper	76
Rear Brake Arrangement	76
Hand Brake Assembly	78

Item	Part Number	Quantity	Description
Braking System - General Arrangement			
1	014748	1	Brake load apportioning valve (LAV) Page 46
2	014816	3	Brake hose MEL 50815
3	014817	2	Brake hose MEL 50928
4	014818	2	. Tee adaptor, brake hose
5	014212	1	Connector, $\frac{3}{16}$ " Kunifer
6	035598	1	Brake pipe RH, server to front brakes
NI	035648	1	Brake pipe LH, server to front brakes
7	035599	1	Brake pipe RH, server to rear brakes
NI	035647	1	Brake pipe LH, server to rear brakes
8	033847	1	Brake pipe, tee to front brakes
9	033846	1	Brake pipe, tee to front brakes
10	033845	2	Brake pipe, rubber hose to front brakes
11	033851	1	Brake pipe, rubber hose to rear connector
12	033849	1	Brake pipe, connector to LAV valve
13	033850	1	Brake pipe, tee to LH rear brake
14	033848	1	Brake pipe, tee to RH rear brake

Item	Part Number	Quantity	Description
Brake Pedal Assembly			
1	014648	1	Brake servo, complete with master cylinder
	011075	3	. Nut, M10
2	100443	1	. Master cylinder
NI	100444	1	. . Repair kit, master cylinder
3	034789	1	. Mounting bracket, brake assembly
	000021	3	. . Setscrew, hex head, M6 x 40mm
	011071	3	. . Nut, M6, Nyloc
4	032910	1	. . Switch, stoplight
5	014812	1	. Adaptor Plate, master cylinder
	000081	2	. . Setscrew, hex head, $\frac{1}{4}$ " UNC x $\frac{1}{2}$ "
6	014813	1	. Mounting bracket, remote reservoir
	011003	2	. . Setscrew, hex head, M6 x 50mm
	011071	2	. . Nut, M6, Nyloc
7	014784	0.7m	. . Hose, brake, $\varnothing 7.5 \times \varnothing 15$
	010960	4	. . . O Clip $\frac{1}{2}$ "
8	014811	2	. . . Hose tail, remote reservoir
9	014783	2	. . . Seal, reservoir mounting
10	046562	1	. . Hose assembly, servo vacuum
11	034787	1	. Brake pedal. LH drive
12	034788	1	. Brake pedal. RH drive
13	100044	1	. . Spring, brake pedal
14	013421	1	. . . Spacer, cab pivot
	000075	1 Bolt, M10 x 130mm
	011075	1 Nut, M10, Nyloc
	100097	1 Clevis pin
	100108	1 Split pin
15	030029	1 Reservoir (spare)
16	030027	1 Cap (remote mounted reservoir)
17	030028	1 Cap float and switch (remote mounted reservoir)

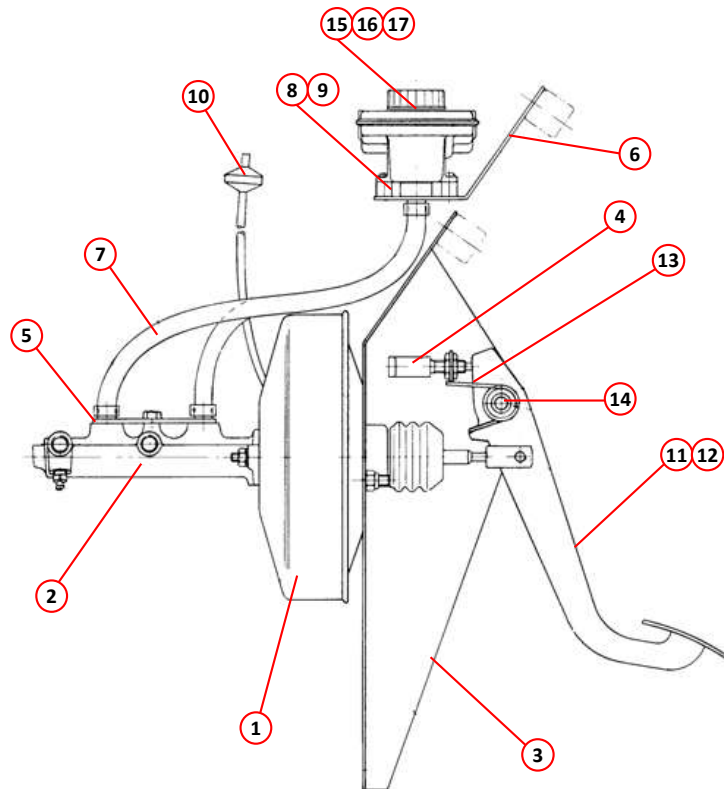
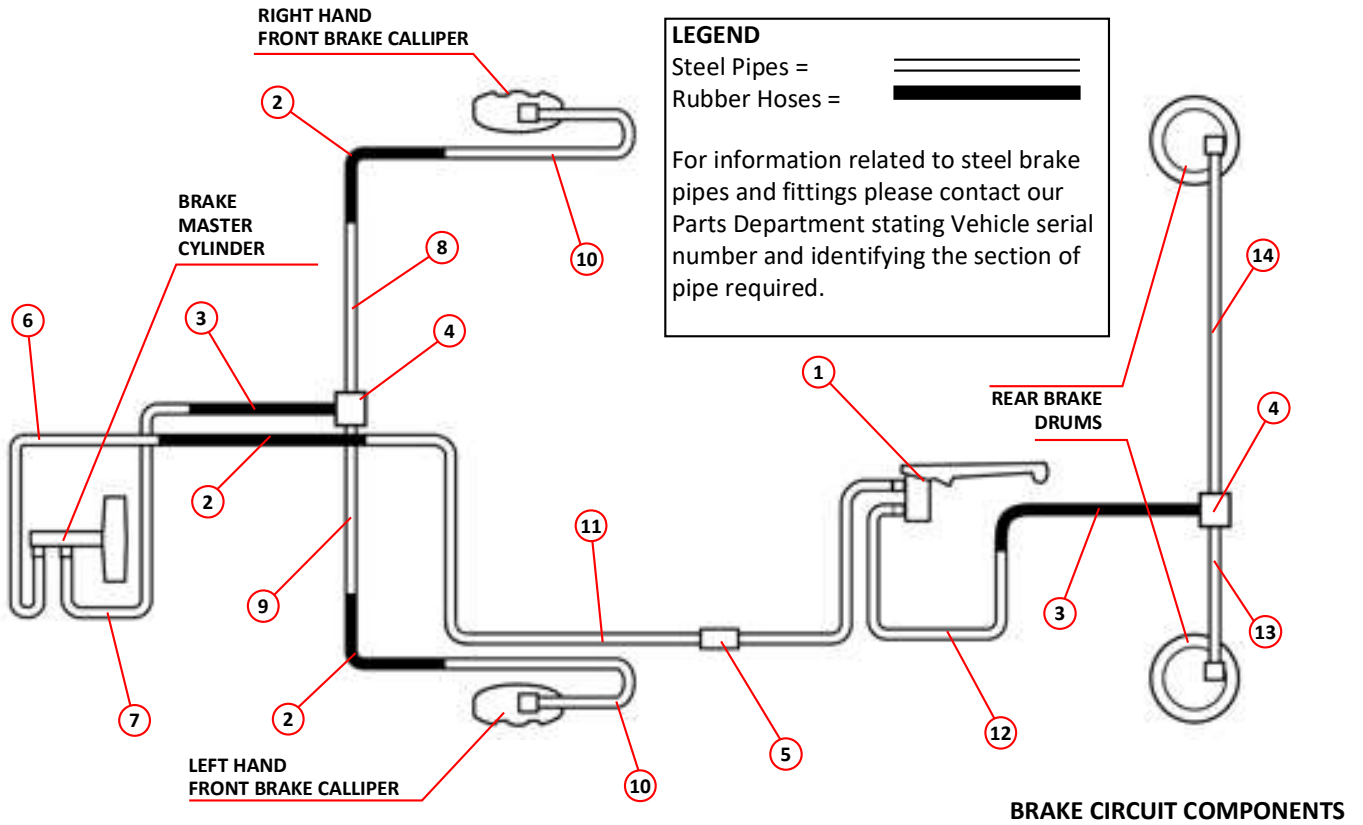

<i>Item</i>	<i>Part Number</i>	<i>Quantity</i>	<i>Description</i>
Front Brake Caliper *			
1	SCAKIT014601	1	Calliper, brake assembly, LH Page 60
1	SCAKIT014602	1	Calliper, brake assembly, RH Page 60
2	011412	2	. Bolt, calliper mounting kit
NI	023323	2	. Pin & spring clip set
3	020138	1	. Disc pad set (4 pads)
4	020139	1	. Disc brake repair kit (1 Wheel)
5	023323	1	. Pin and spring clip kit
6	000238	2	. Bleed point
7	014816	2	Hose, brake pipe
8	014774	1	. Brake pipe hose bracket (LH)
8	014775	1	. Brake pipe hose bracket (RH)
9	033845	1	Calliper steel brake pipe
10	014594	2	Brake disc, front Page 60

<i>Item</i>	<i>Part Number</i>	<i>Quantity</i>	<i>Description</i>
Rear Brake Arrangement *			
1	020134	1	Brake assembly, LH complete
1	020133	1	Brake assembly, RH complete
2	020118	1	. Back plate, LH
2	020117	1	. Back plate, RH
3	020119	1	. . Plug, rubber
4	020128	1	. . Wheel cylinder, LH
4	020127	1	. . Wheel cylinder, RH
NI	003018	AR	. . . Clip, wheel cylinder
5	020129	1	. . . Bleed screw
6	020126	AR	. . Seal kit, wheel cylinder
7	020120	1	. Brake shoe kit (complete axle set)
8	020125	1	. . Shoe hold down kit
9	020121	1	. . Adjuster kit (complete axle set)
10	020124	1	. Handbrake lever, LH
10	020123	1	. Handbrake lever, RH
11	020122	1	. . Pivot pin kit
12	020132	1	. Cross lever
13	020131	1	. . Spring kit, LH
13	020130	1	. . Spring kit, RH
NI	020199	1	Brake drum

Notes:-

* For any steel brake pipes please contact Scarab Parts Department.

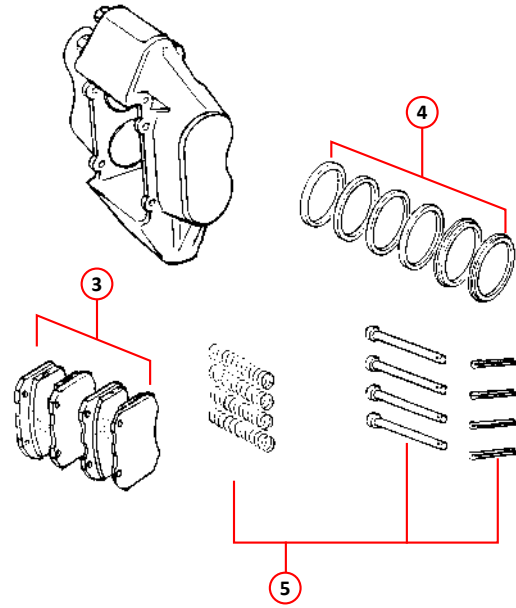
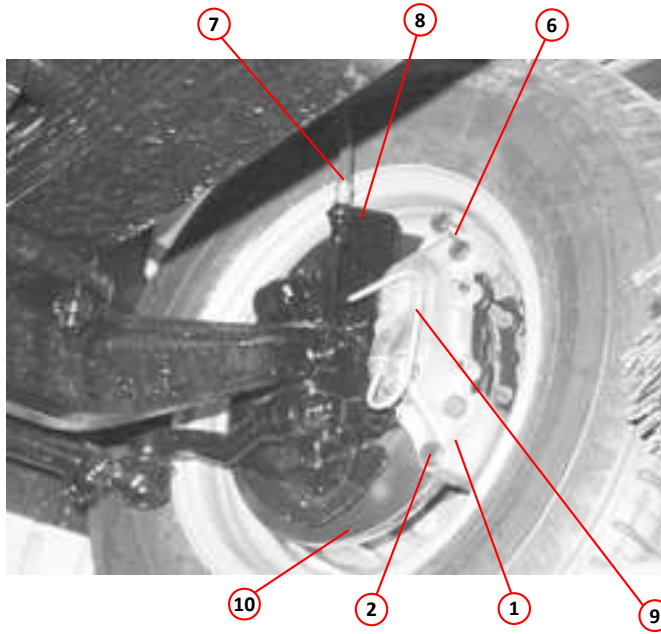

FRONT BRAKE CALIPER ASSEMBLY

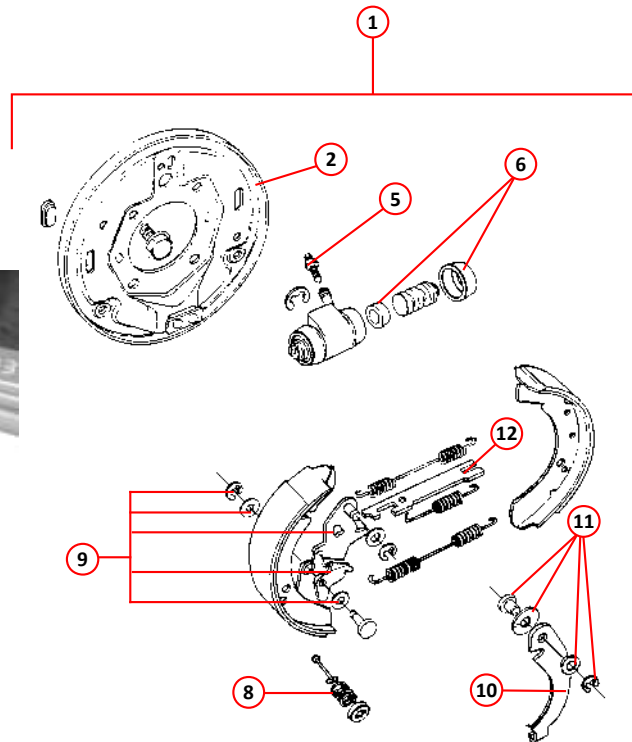
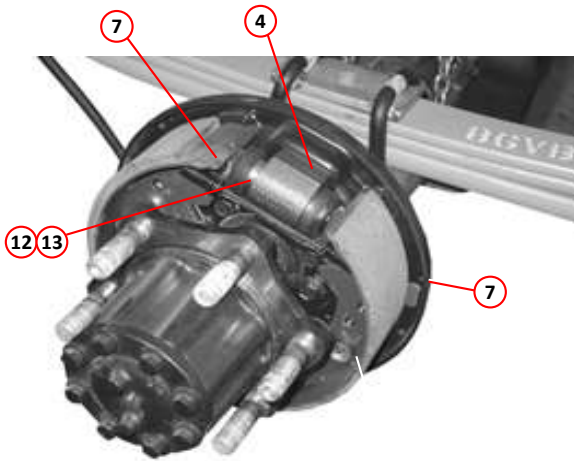

REAR BRAKE ASSEMBLY

<i>Item</i>	<i>Part Number</i>	<i>Quantity</i>	<i>Description</i>
Hand Brake Assembly			
1	026792	1	Support, hand brake
	011011	3	. Setscrew, M8 x 25mm
	011073	7	. Nut, M8, Nyloc
2	026811	1	. Lever, hand brake Page 88
3	100105	1	. . Clevis pin
	100106	1	. . . Split pin
4	014821	1	. . Cable, hand brake, primary (8mm eyelet)
4a	035679	1	. . Cable, hand brake, primary, RH routing
5	012876	1	. . . Grommet, I/D 11mm - O/D 19mm
6	032910	1	Handbrake switch Page 223
7	032051	1	. Handbrake switch plunger
8	032049	1	. Support bracket
9	033218	1	. . Wiring loom
NI	027790	1	. . . Pin kit
10	100096	1	. . Equalizer
11	100097	4	. . . Clevis pin
	100108	4 Split pin
12	100047	1	. . . Spring, brake retracting
13	100278	1	. . . Cable, secondary (drum to drum)
14	033235	2	. Link
15	033234	1	. Cranked link

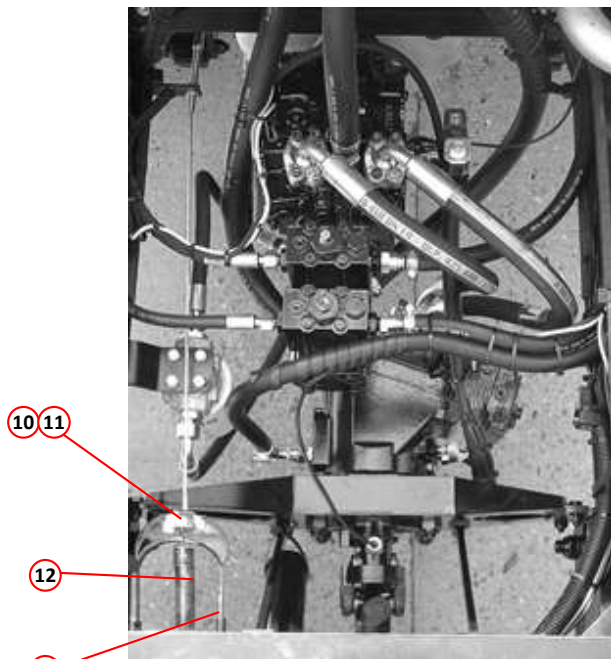
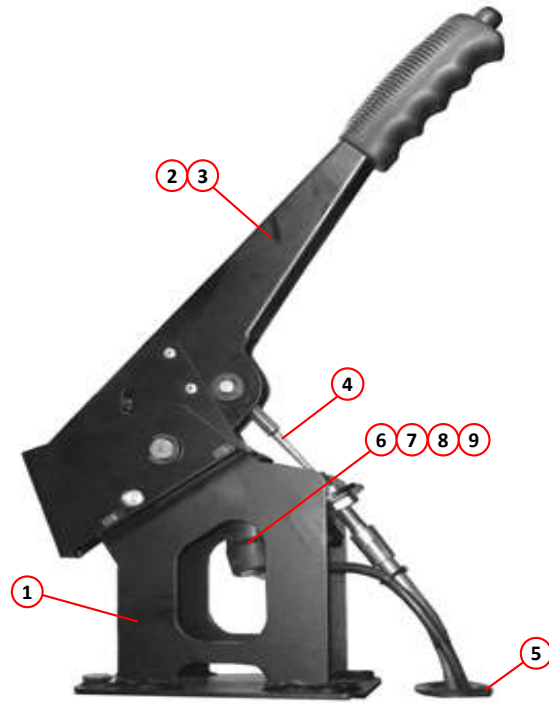

HANDBRAKE LINKAGE ON LH SIDE

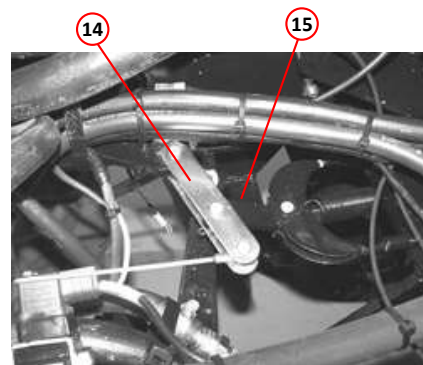

HANDBRAKE LINKAGE ON RH SIDE

HANDBRAKE ASSEMBLY

Cab Components

<i>Assembly/Description</i>	<i>Page</i>
Cab External Components and Associated Parts	82
Cab External Components and Associated Parts	84
Cab Interior and Associated Parts	86
Cab Interior and Associated Parts	88
Cab Interior and Associated Parts	90
Steering Column Assembly	92
Cab Safety Latch Assembly	94
Cab Locking Assembly	94
Hydraulically Assisted Cab Tilt	96
Hydraulically Assisted Cab Tilt - Circuit Components	98
Cab Heater and Optional Air Conditioning Arrangement	100
Air Conditioning Compressor Arrangement	100
Air Conditioning Condenser/Radiator Arrangement	102

Item	Part Number	Quantity	Description
Cab External Components and Associated Parts			
1	036875	1	Cab body, standard model
NI	037998	1	Cab body, low roof model
2	036882	1	. Roof, GRP
NI	037777	1	. . Roof insulation panel
	011033	6	. . Setscrew, M6 x 50mm
	011090	6	. . Washer, M6
3	036892	1	. Windscreen
4	010304	1	. Beacon, 12 Volt
5	030926	1	. Aerial
6	013941	1	. Mirror, (always fitted off-side)
NI	037115	1	. . Mirror adaptor plate
	000377	2	. . . Screw, socket countersunk, $\frac{1}{4}$ " UNF x $\frac{3}{8}$ "
	011068	2	. . . Setscrew, M6 x 40mm
	011091	2	. . . Washer, spring, M6
	011090	2	. . . Washer, M6
7	033107	2	. Mirror, LH/RH
8	033108	2	. . Mirror arm
	011068	4	. . . Setscrew, M6 x 35mm
	011090	4	. . . Washer, M6
9	013941	1	. Mirror, dual sweep only (always fitted off-side)
	000377	4	. . Screw, socket cap head, $\frac{1}{4}$ " UNF x $1\frac{3}{4}$ "
	011091	2	. . Washer, spring, M6
	011090	4	. . Washer, M6
10	035204	1	. Wiper arm, passenger side LH drive, driver side RH drive
11	035209	1	. Wiper arm, driver side LH drive, passenger side RH drive
NI	035205	2	. . Wiper blade
12	037123	1	. Headlight cover, GRP, RH
	000384	3	. . Screw, flange head self-tapping, No10 x $\frac{3}{4}$ "
13	037132	1	. Grill front panel
	040473	1	. . Badge, Minor, grill front panel
	000384	3	. . Screw, flange head self-tapping, No10 x $\frac{3}{4}$ "
14	037122	1	. Headlight cover, GRP, LH
	000384	3	. . Screw, flange head self-tapping, No10 x $\frac{3}{4}$ "
15	037118	1	. Light cluster bracket, RH
NI	036899	1	. Light cluster bracket, LH
	000090	4	. . Screw, socket button head, M6 x 16mm
	011091	4	. . Washer, spring, M6
	011090	4	. . Washer, M6
16	034847	2	. Headlight main beam & side light Page 224
	011499	2	. . Bulb headlight, 12 Volt 55 Watt Page 224
	011500	2	. . Bulb sidelight, 12 Volt 4 Watt Page 224
17	034850	2	. Front turn signal Page 224
	004416	2	. . Bulb front turn signal Page 224
18	034848	2	. Headlight dip beam Page 224
	011499	2	. . Bulb headlight, 12 Volt 55 Watt Page 224
19	036190	2	. Gas spring, cab tilt
20	023110	2	. . Bellows, gas spring
21	027734	2	. Cab pivot bracket Page 42
	011038	2	. . Bolt, M10 x 80mm
	011095	4	. . Washer, M10
	011075	2	. . Nut, M10, Nyloc
22	034849	2	. Turn/hazard, side indicator (complete with bulb) Page 224
	011487	2	. Capless bulb for side turn indicator Page 224
23	037125	1	. Lower skirt, RH
NI	037124	1	. Lower skirt, LH
	011001	8	. . Setscrew, M6 x 16mm
	011099	8	. . Repair washer, $\frac{1}{4}$ "

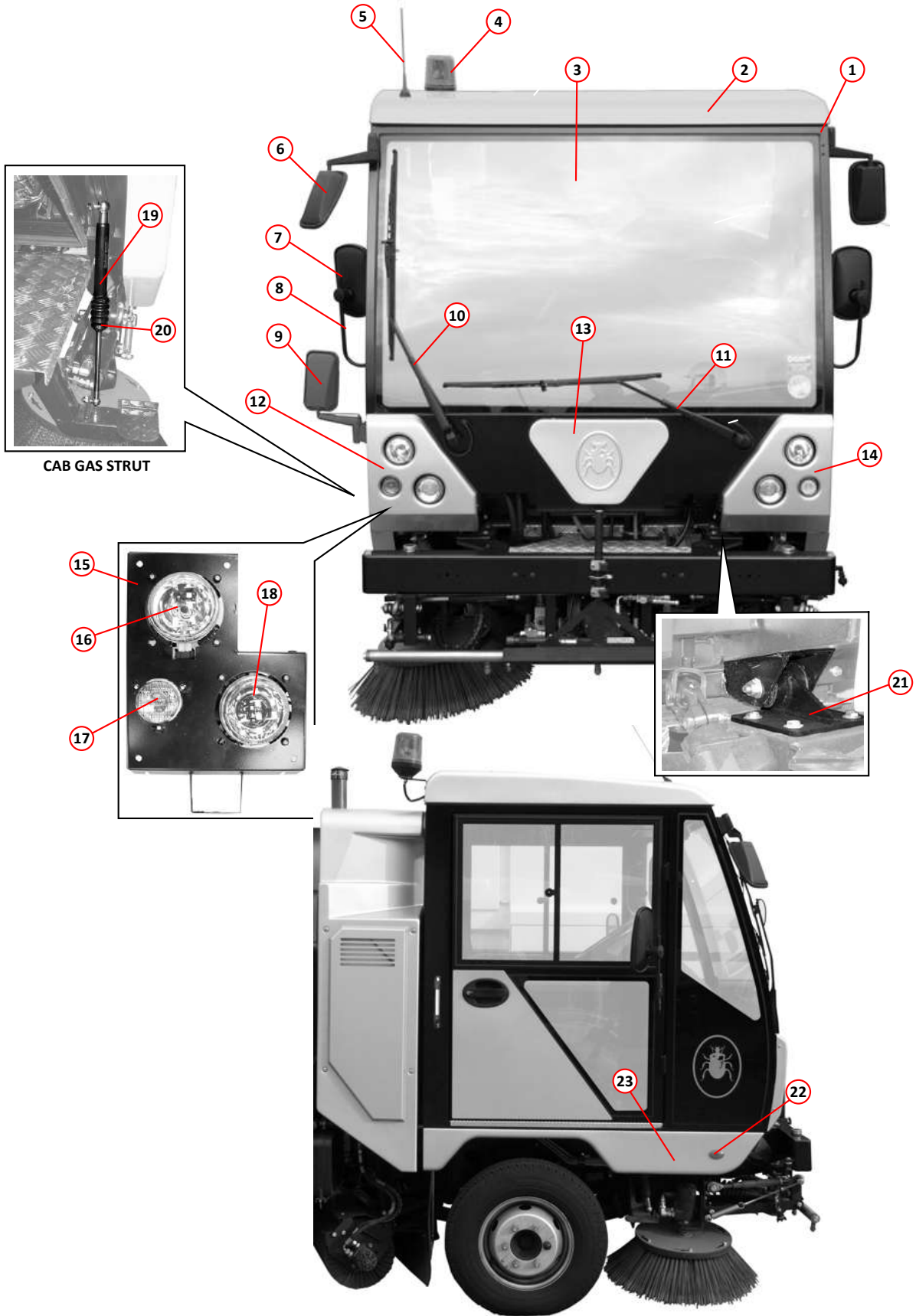

CAB ARRANGEMENT (LEFT HAND-DRIVE SHOWN)

Item	Part Number	Quantity	Description
Cab External Components and Associated Parts - Continued			
24	036878	1	Door, RH (complete assembly)
NI	036877	1	Door, LH (complete assembly)
25	036886	1	. Glass, quarter light, front RH
NI	036885	1	. Glass, quarter light, front LH
26	037134	1	. Exterior pull handle, complete with gasket (Sold as a pair)
	000097	6	. . Setscrew, M5 x 12mm
27	036881	1	Glass, quarter light, rear RH
28	036880	1	Glass, quarter light, rear LH
29	036853	1	Cab extension RH Page 130
NI	034590	1	Cab extension LH Page 130
	026417	8	. Dzus stud
	023229	24	. Retainer
30	036229	1	. Handle
	011010	2	. . Setscrew, M8 x 20mm
	000089	2	. . Dome nut, M8
31	036891	1	. Sliding window assembly RH
NI	036890	1	. Sliding window assembly LH
32	037126	1	. Check strap, small
33	037127	1	. Check strap, large 1
34	037128	1	. Check strap, large 2
	011011	6	. . Setscrew, M8 x 25mm
	011093	12	. . Washer, M8
	011073	6	. . Nut, M8, Nyloc
35	037136	2	. . Squeeze lever
	000384	2	. . Screw, flange head self-tapping, No10 x $\frac{3}{4}$ "
36	036888	1	. . Door lower glass RH
NI	036887	1	. . Door lower glass LH
37	037112	1	. . Door cover/arm rest RH
NI	037111	1	. . Door cover/arm rest LH
38	037130	2	. . . Arm rest
	000384	6	. . . Screw, flange head self-tapping, No10 x $\frac{3}{4}$ "
39	037138	1	. . Anti-burst latch RH
NI	037137	1	. . Anti-burst latch LH
	000371	4	. . . Screw, socket countersunk, M8 x 25mm
40	037979	1	. . Door linkage
41	037902	2	. . Cable
42	037119	2	. Striker pin bracket
43	037133	2	. . Striker pin
44	037120	2	. . Striker pin cover

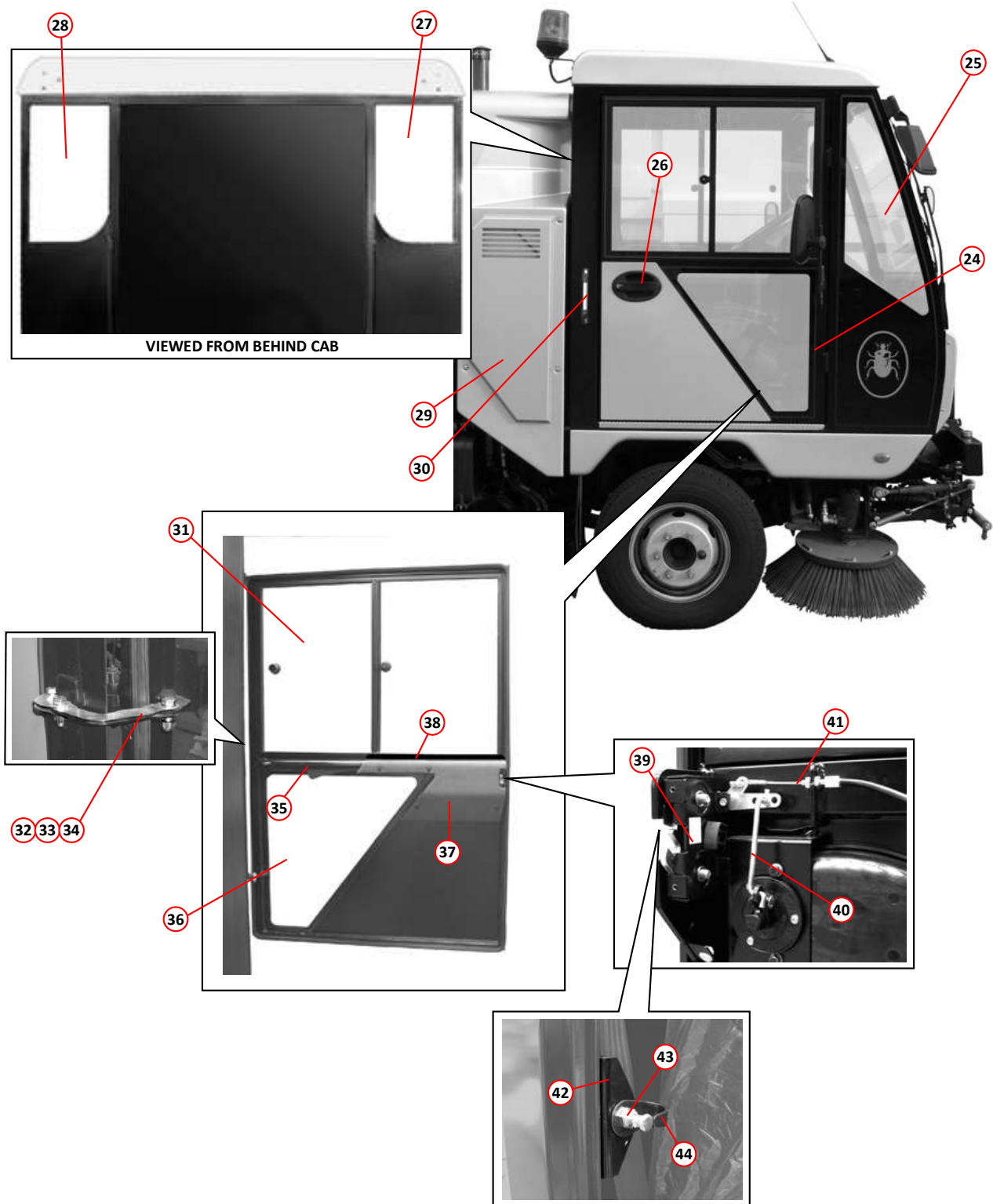

CAB ARRANGEMENT (LEFT HAND-DRIVE SHOWN)

Item	Part Number	Quantity	Description
Cab Interior and Associated Parts - Left Hand Drive Shown			
1	020272	2	Grab handle
	000350	4	. Screw, socket button head, M6 x 20mm
2	032808	1	Panel, speedometer & driving instruments
2	040151	1	Panel, speedometer & driving instruments (NSSTA)
3		1	Steering column Page 92
4	031893	1	Steering column cover
5	042354	1	Display screen (programmed) Page 216
NI	038999	1	. Seal, display screen
NI	041289	1	. Voltage stabiliser Page 223
6	039024	1	. Mounting plate, display screen and main control panel
NI	039026	1	. . Nut plate, LH drive
NI	039027	1	. . Nut plate, RH drive
	000342	12	. . . Screw, socket button head, M4 x 16mm
NI	036916	1	. Wiring loom, display screen Page 222
7		1	Keypad, main control panel complete Page 216
NI	037055	1	. Fixing plate, main control panel
	000346	8	. . Screw, socket button-head, M5 x 16mm
	000155	8	. . Nut, M5, Nyloc
8	037073	1	. . Ball joint, main control panel mounting
NI	036912	1	. Wiring loom, main control panel Page 222
9		1	Auxiliary control panel Page 216
9a		1	Auxiliary control panel, new fan symbols Page 216
NI	036913	1	. Wiring loom, Auxiliary control panel Page 222
10	039018	1	. Mounting plate, auxiliary control panel, LH
NI	039019	1	. Mounting plate, auxiliary control panel, RH
NI	037064	1	. . Clamp, fixing plate
	011032	1	. . . Setscrew, M10 x 30mm
	000405	2	. . Screw, socket button head, black, M8 x 12mm
11	028108	1	12 volt power outlet socket Page 223
12	031599	1	Radio/CD player Page 223
13	030587	1	Bottle, windscreen washer fluid with 12 volt pump
NI	030588	1	. Washer fluid bottle bracket
	000384	2	. . Screw, flange head self-tapping, No10 x $\frac{3}{4}$ "
NI	026161	1	Cab heater Page 100
NI	031632	1	Heater control module, with cable
14	031633	1	Heater control module with air conditioning control), with cable Page 100
NI	031638	1	. Nut plate, heater control
	000304	4	. Screw, socket button head, M4 x 10mm
15	013914	1	Switch housing
16	031406	2	. Switch, off/on Page 223
	031412	1	. . Switch symbol, insert (beacon)
17	031406	1	. Switch, off/on Page 223
17a	038997	1	. Switch, momentary Page 223
	031410	1	. . Switch symbol, insert (fog lights)
18	031407	1	. Switch, off/on/on Page 223
	031409	1	. . Switch symbol, insert (side lights/head lights)
18a	039188	1	. . Switch symbol, insert (light master)
19	013914	1	Switch housing
20	031408	1	. Switch, hazard warning lights Page 223
	031412	1	. . Switch symbol, insert (hazard warning lights)
21	013259	2	. . Blanking plate

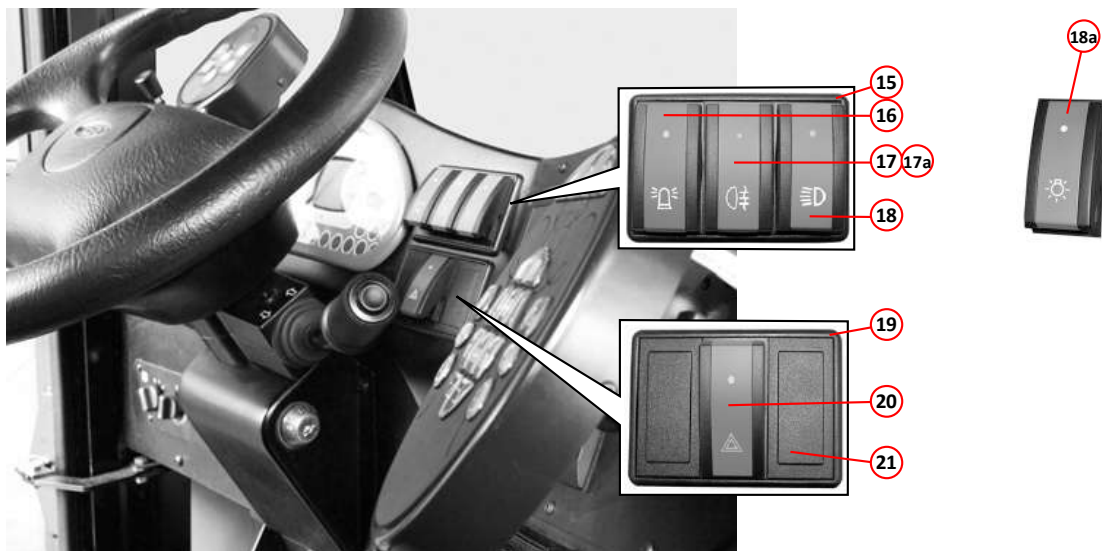

CAB INTERIOR AND ASSOCIATED PARTS - LEFT HAND DRIVE SHOWN

Item	Part Number	Quantity	Description
Cab Interior and Associated Parts - Left Hand Drive Shown - Continued			
22	035432	1	Wiper linkage assembly, LH drive, complete with motor
NI	040003	1	. Guard, wiper mechanism, motor side, LH drive
NI	040004	1	. Guard, wiper mechanism, non motor side, LH drive
NI	035433	1	Wiper linkage assembly, RH drive, complete with motor
NI	040005	1	. Guard, wiper mechanism, motor side, RH drive
NI	040006	1	. Guard, wiper mechanism, non motor side, RH drive
23	035202	1	. Wiper motor Page 223
	000304	4	. Screw, socket button head, M4 x 10mm
	000340	4	. Lug nut, M6
24	036793	1	. . Crank arm
25		1	Fuse/relay panel Page 218
26	042336	1	. Node 03, mobile controller CR0020 (programmed) Page 218
27	034792	1	. Fuse box access cover
	021327	1	. Stud fastener
	021328	1	. . Stud fastener retainer
	021326	1	. Fastener receptacle
	014959	1	. Hinge
	000028	4	. . Screw, slotted round head, 2BA x $\frac{1}{2}$ "
	011078	4	. . Nut, 2BA, Nyloc
28	033214	1	Lower cover, heater/electrics, LH
NI	033213	1	Lower cover, heater/electrics, RH
	000350	3	. Screw, socket button head, M6 x 20mm
	000340	3	. . Lug nut, M6
29	031836	1	. Lower cover retainer
NI	031837	1	. Lower cover retainer strip
30	013952	AR	. Rubber, weather seal
	000338	6	. . Screw, socket button head, M6 x 16mm
31	026161	1	. Cab heater Page 100
	000350	5	. . Screw, socket button head, M6 x 20mm
32		3	. Node, cabinet module (CR2012) Page 216
NI	037903	AR	. . Bracket, Node (CR2012)
33	039065	2	. LED current source Page 216
NI	019123	1	. Horn
34	036680	2	Door protection strip
35	036681	1	Floor protection strip
36	013426	1	Floor plate
37	032617	1	Foot pedal, speed controller
NI	039065	1	. 12volt to 5volt power supply (behind fuse board) Page 218
	000329	2	. Screw, socket button head, M8 x 20mm
	011072	2	. Nut, M8
	011093	2	. Washer, spring, M8
	011092	2	. Washer, M8
38	014958	2	Toolbox door
39	021327	2	. Stud fastener
	021328	2	. . Stud fastener retainer
40	021326	2	. Fastener receptacle
41	014959	4	. Hinge
NI	028320	4	. . Hinge spacer
	000028	16	. . . Screw, slotted round head, 2BA x $\frac{1}{2}$ "
	011078	16	. . . Nut, 2BA, Nyloc
42		1	Handbrake assembly Page 76
	011073	4	. Nut, M8, Nyloc
	011092	4	. Washer, M8
43	*	1	Hopper controller complete Page 216
44	044294	1	Hopper controller, complete with holster Page 216

Notes:-

* As of March 2016 if you have one of these controllers then please order item 44 instead.

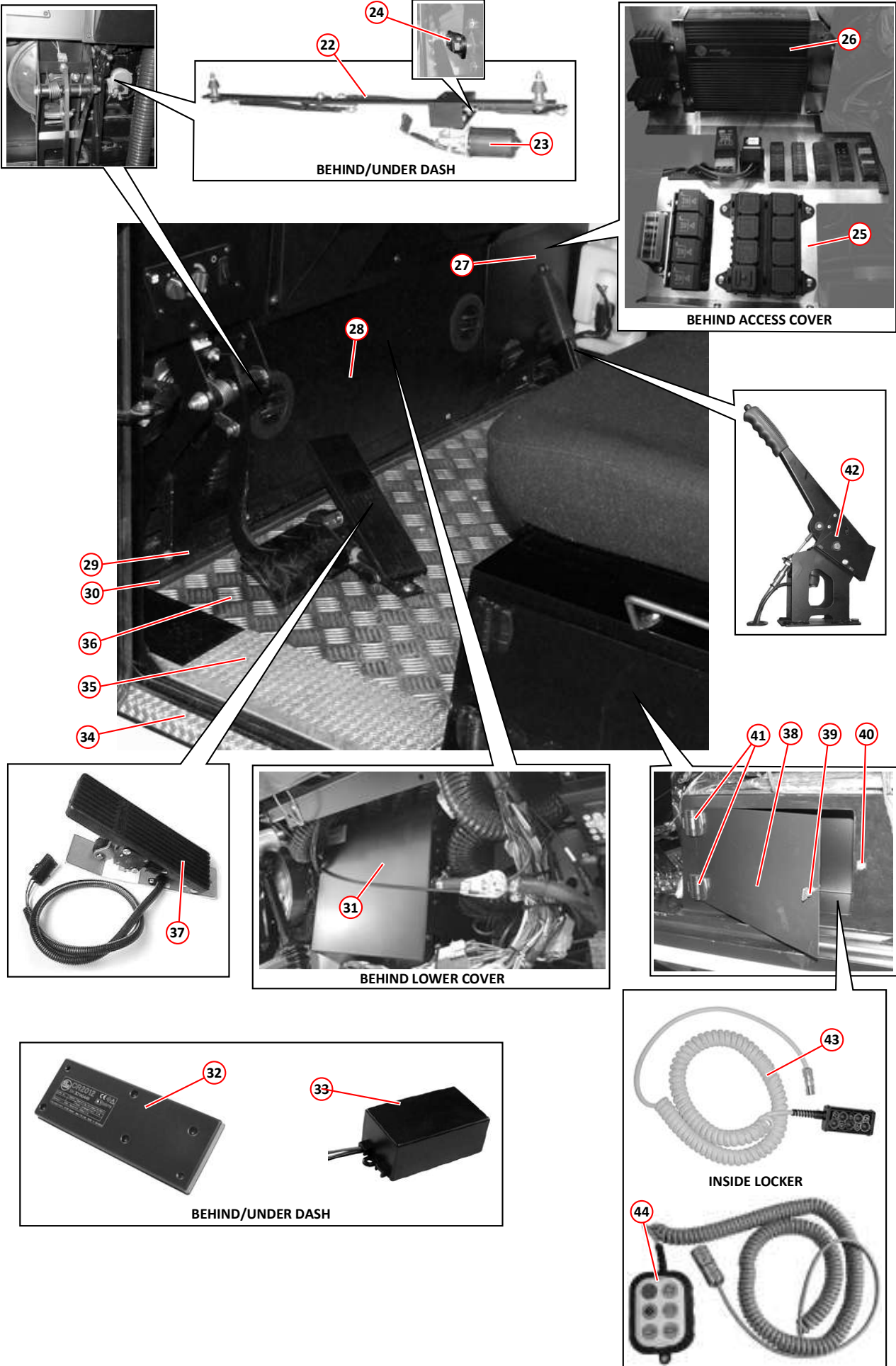

CAB INTERIOR AND ASSOCIATED PARTS - LEFT HAND DRIVE SHOWN

Item	Part Number	Quantity	Description
Cab Interior and Associated Parts - Left Hand Drive Shown - Continued			
44	036893	2	Roof panel, trim
NI	037778	1	. Roof panel, soundproofing
45	013935	2	Sun visor
	000384	4	. Screw, flange head self-tapping, No10 x $\frac{3}{4}$ "
46	040717	1	Camera monitor Page 216
47	034279	1	. Monitor mounting bracket
48	013514	1	Suction fan scraper Page 136
	013631	2	. Clip, Fir Tree
49	013749	1	Interior light
	000384	2	. Screw, flange head self-tapping, No10 x $\frac{3}{4}$ "
50	037977	1	Rear panel trim
NI	037779	1	. Rear panel insulation
51	038383	1	Coat hanger
52	037780	2	Rear panel trim and insulation, side
53	025927	1	Seat, LH
NI	025928	1	Seat, RH
	011010	4	. Setscrew, M8 x 20mm
	011092	4	. Washer, M8
	011073	4	. Nut, M8, Nyloc
NI	025929	AR	. Head restraint
54	020513	2	Seat belt and fixings
55	036063	2	Seat belt guide
	011001	4	. Setscrew, M6 x 20mm
	011090	4	. Washer, M6
	011071	4	. Nut, M6, Nyloc
56	018227	1	Cab locking assembly Page 94
57	034808	1	Centre console
	011115	4	. Screw, flange head self-tapping, No10 x $\frac{1}{2}$ "
	011145	4	. Washer, 2BA
58	013633	1	First aid box
NI	037802	1	. Bracket, mounting, first aid box
	000086	4	. Screw, slot head countersunk, M3 x 20mm
	000114	4	. Nut, M3, Nyloc
59	039028	1	Dash, GRP, LH drive
NI	039029	1	Dash, GRP, RH drive
	000338	6	. Screw, socket button head, M6 x 16mm
	000340	6	. Lug nut, M6
	014563	7	. Fir tree button
60	031892	1	. Brake fluid access panel, LH drive
NI	031894	1	. Brake fluid access panel, RH drive
	031959	2	. . Arrow fastener
61	031745	Pair	. Speakers, flush mounted
62	010478	1	Hand lance (option) located in front and below seats Page 168
63	037103	1	. Hand lance retaining strap
NI	037104	1	. . Striker, hand lance retaining strap
64	011893	1	. Hand lance retaining ring
65	041534	1	Camera splitter Page 223

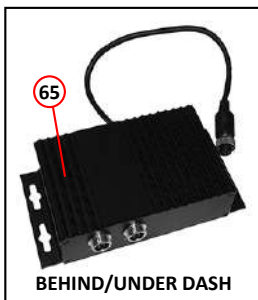
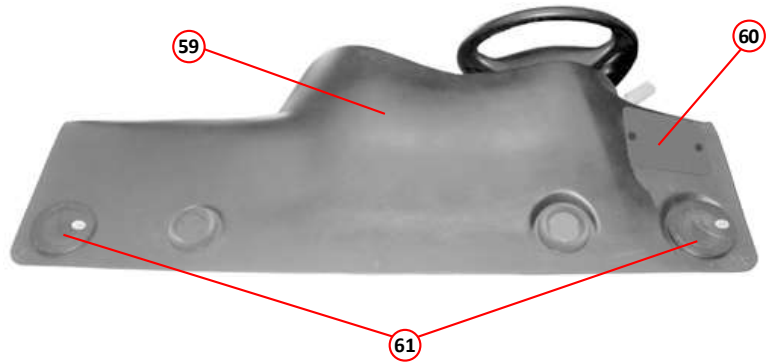
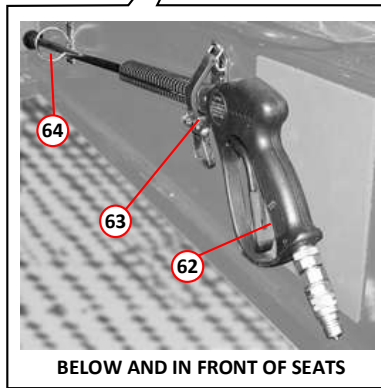
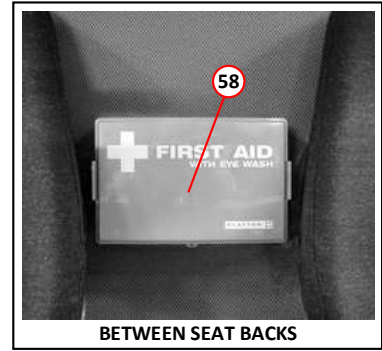
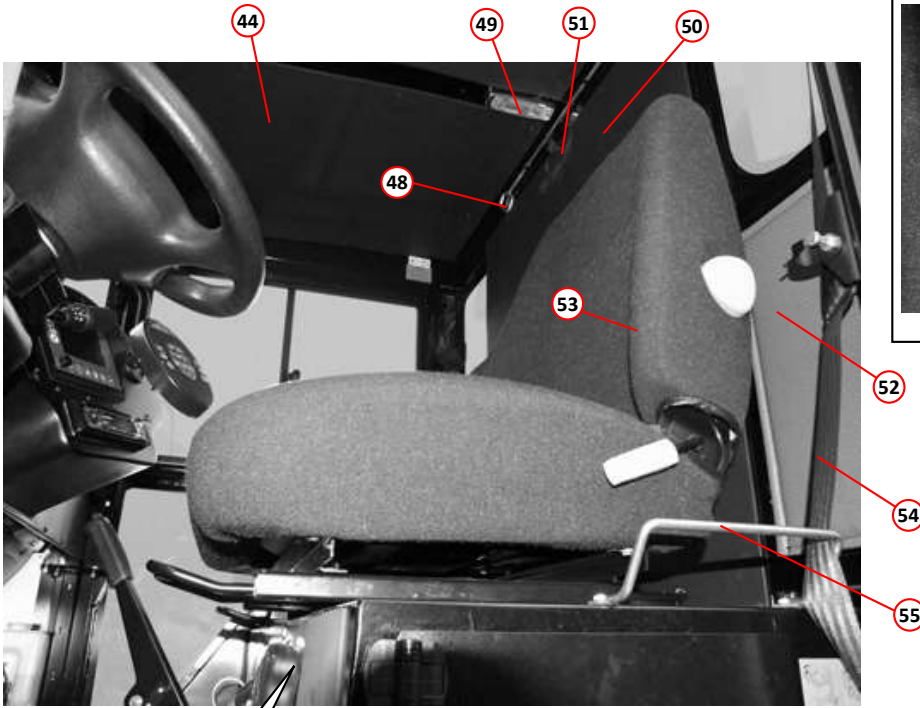
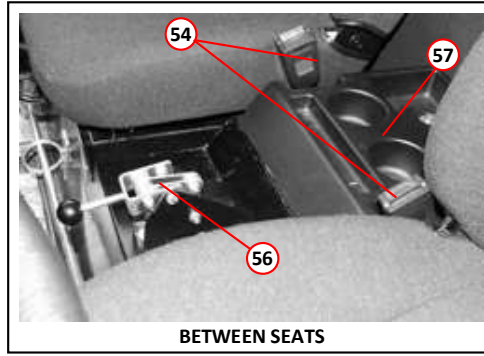
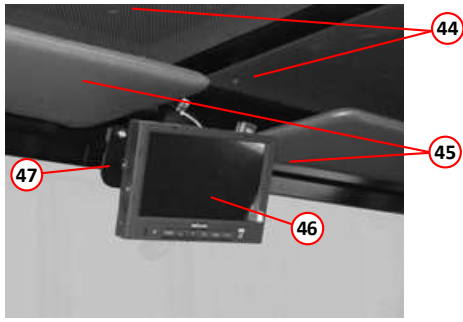

CAB INTERIOR AND ASSOCIATED PARTS - LEFT HAND DRIVE SHOWN

<i>Item</i>	<i>Part Number</i>	<i>Quantity</i>	<i>Description</i>
Steering Column Assembly			
1	031616	1	Steering column - outer
2	041021*	1	Steering column - upper
3	031621	2	Bearing 6004.2RSR
4	035604	1	ø20 Starlock
5	011102	1	Washer, M20
6	041023*	1	Indicator cancelling boss
7	000052	1	Setscrew, M5 x 16mm
8	000054	1	Nut, M5, Full
9	031617	1	Ignition key switch/steering lock
10	031405	1	Switch, gear select column
11	031404	1	Switch, Multifunction column
12	000341	1	Screw, socket cap head M5 x 16mm
13	040351	1	Windscreen washer, wiper label
14	041025*	1	Bellows
15	041022*	1	Steering wheel
16	011096	1	Washer, M12
17	011077	1	Nut, M12, Nyloc
18	039481*	1	Boss cover, steering wheel (with Scarab Logo)
19	033059	1	Steering column - lower
20	014473	1	Bellows
21	000096	2	Screw, socket cap head, M8 x 40mm
22	011073	2	Nut, M8, Nyloc
23	041020	1	Complete steering column assembly Page 86

Notes:-

* If your sweepers serial number is lower than 8467 then you will need to fit all parts marked with a * or fit the complete steering column assembly part number 041020.

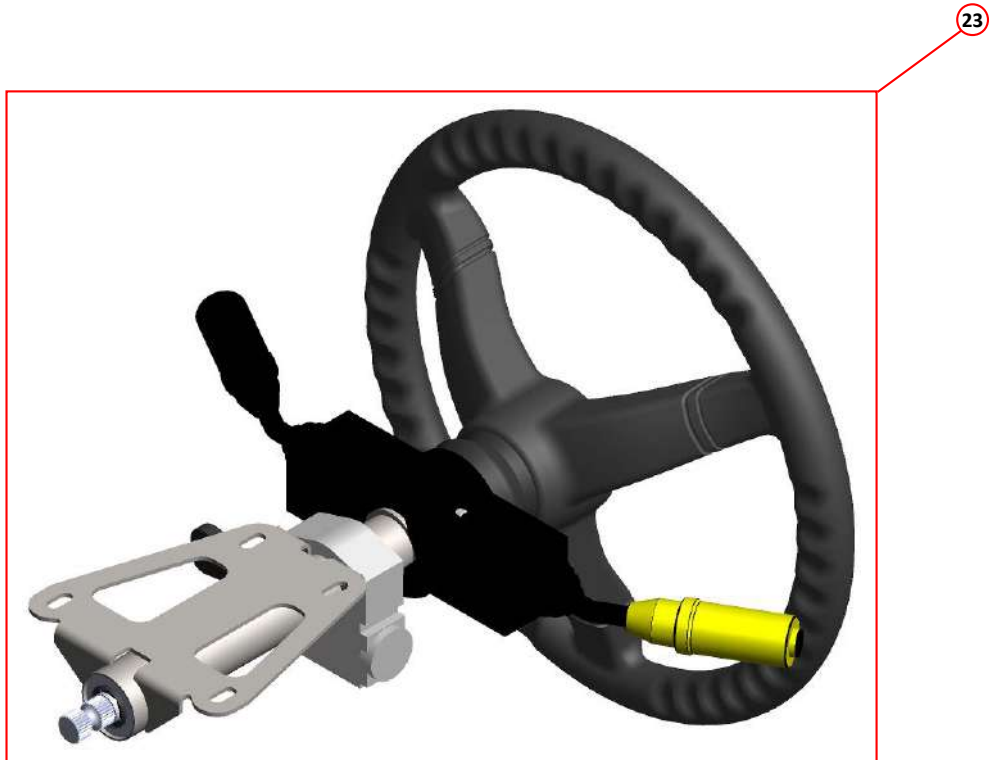
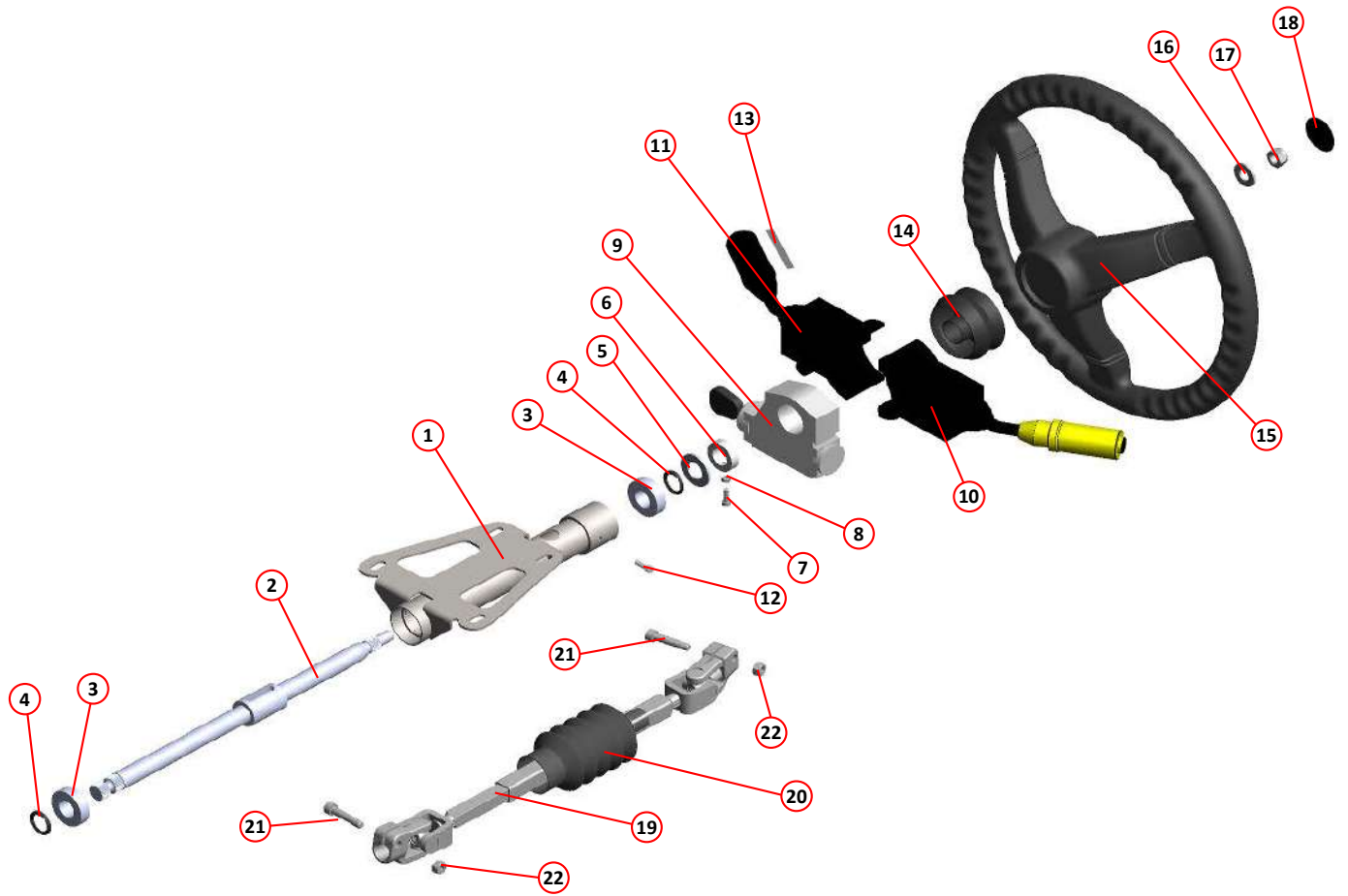

STEERING COLUMN ASSEMBLY

<i>Item</i>	<i>Part Number</i>	<i>Quantity</i>	<i>Description</i>
Cab Safety Latch Assembly			
1	033431	1	Cab latch
2	033410	1	. Spring, cab latch
	011092	1	. Washer, M8
	011073	1	. Nut, M8, Nyloc
3	033007	1	. Bracket, cab latch
	011010	2	. . Setscrew, M8 x 20mm
	011092	2	. . Washer, M8
	011073	2	. . Nut, M8, Nyloc
4	033432	1	. Bracket, cab latch
	011010	1	. . Setscrew, M8 x 20mm
	011092	1	. Washer, M8
	011073	1	. Nut, M8, Nyloc
NI	000040	1	Bolt, M10 x 55mm (Latch Point)
	011074	1	. Nut, M10
	011075	1	. Nut, M10, Nyloc

<i>Item</i>	<i>Part Number</i>	<i>Quantity</i>	<i>Description</i>
Cab Locking Assembly			
1	048350*	1	Base, in-line cab lock
2	035774	1	Nut plate, cab lock, (located underneath cab)
3	011092	2	Washer, M8
4	011010	2	Setscrew, M8 x 20mm
5	013867*	1	Handle, cab lock
6	013865*	1	Knob, cab lock
7	013869*	1	Link arm
8	000018*	1	Bolt, M6 x 55mm
9	011090*	1	Washer, M6
10	011071*	1	Nut, M6, Nyloc
11	011001*	2	Bolt, M6 x 16mm
12	011090*	2	Washer, M6
13	011071*	2	Nut, M6, Nyloc
14	013868*	1	Hook, cab lock
15	000011*	1	Bolt, M6 x 60mm
16	011090*	1	Washer, M6
17	011071*	1	Nut, M6, Nyloc
18	011087*	1	Bolt, M6 x 25mm
19	011090*	1	Washer, M6
20	011071*	1	Nut, M6, Nyloc
21	021904	1	Cab latch, eye bolt
	011029	1	Screw, socket cap head, M8 x 35mm
22	014834	1	Cab locking strap
23	013466	2	. Bump stop
24	037051	2	. . Support plate, bump stop
	011013	4	. . . Setscrew, M8 x 35mm
	011073	4	. . . Nut, M8, Nyloc

Notes:-

* Can be purchased as a complete assembly by ordering Part No. 035775 - Cab Locking Assembly

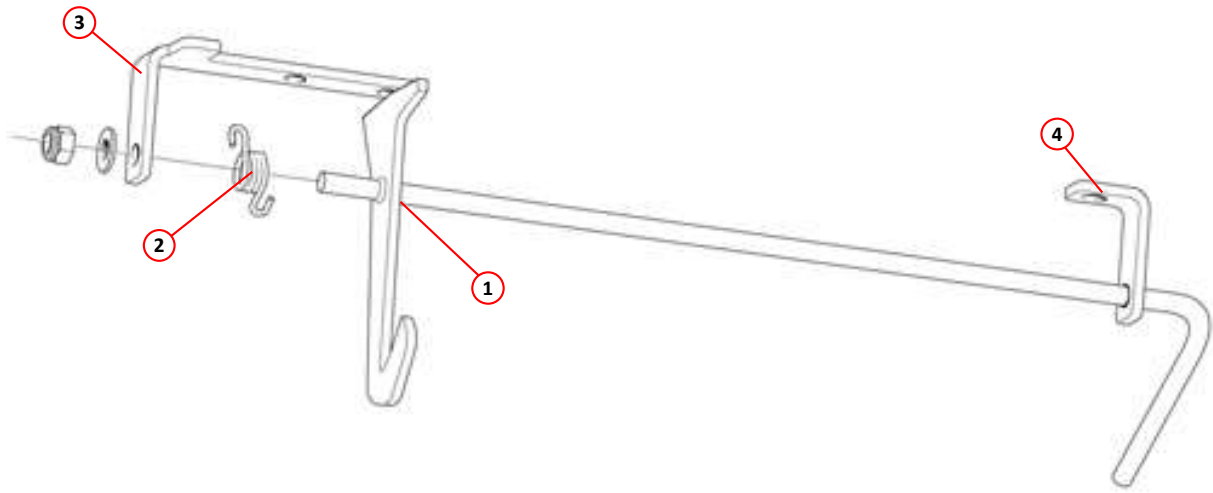

CAB SAFETY LATCH ASSEMBLY

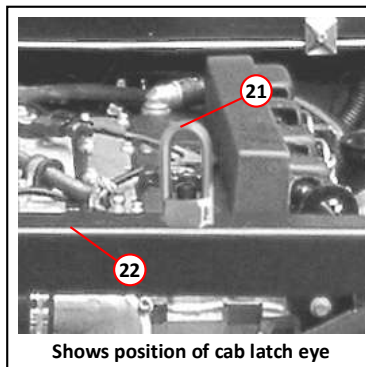
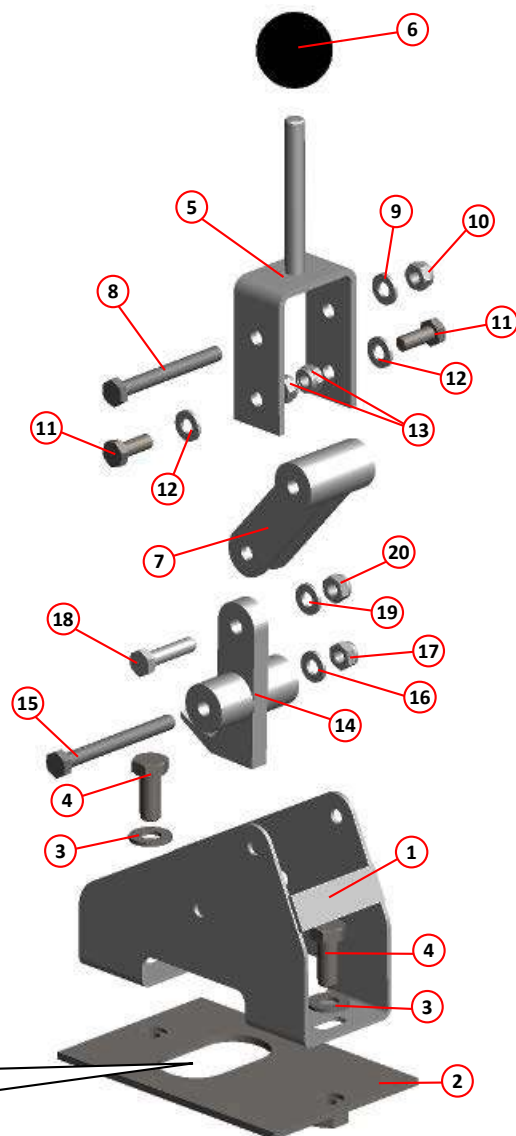
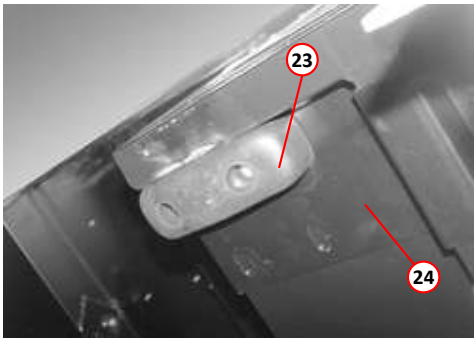

Shows position of cab latch eye

CAB LOCKING ASSEMBLY

Item	Part Number	Quantity	Description
Hydraulically Assisted Cab Tilt			
1	032810	1	Hydraulic ram, double acting Page 204
	011152	1	. Seal, Dowty, $\frac{1}{4}$ " BSP
2	033748	1	. . Adaptor, restrictor 0.5mm, M/M, $\frac{1}{4}$ " BSP (Gold)
3	011169	1	. . . Elbow, swivel, M/F, $\frac{1}{4}$ " BSP
4	035443	1	. Bracket, upper pivot, outer
5	035445	1	. . Spacer
6	035444	1	. . Bracket, upper pivot, inner
	011038	1	. . Bolt, M10 x 80mm
	011075	1	. . Nut, M10, Nyloc
	011152	1	. Seal, Dowty, $\frac{1}{4}$ " BSP
7	011269	1	. . Adaptor, bulkhead, M/M, $\frac{1}{4}$ " BSP
8	011169	1	. . . Elbow, swivel, M/F, $\frac{1}{4}$ " BSP
9	032474	2	. Pin, lower pivot
	000084	2	. . Pin, split, $\frac{3}{32}$ " x 1"
10	032830	1	. Step, LH
NI	032831	1	. Step, RH
11	038895	1	Bracket, hand-pump mounting
	000221	4	. Bolt, M8 x 25mm
	011073	4	. Nut, M8, Nyloc
12	023006	1	. Hand pump
NI	038657	1	. . Handle
	000221	3	. . Bolt, M6 x 80mm
	011071	3	. . Nut, M6, Nyloc
	011152	1	. . Seal, Dowty, $\frac{1}{4}$ " BSP
13	011158	1	. . . Adaptor, M/M, $\frac{1}{4}$ " BSP
14	011169	1 Elbow, swivel, M/F, $\frac{1}{4}$ " BSP
15	011206	1 Tee, M/M/F, $\frac{1}{4}$ " BSP
	011152	1	. . Seal, Dowty, $\frac{1}{4}$ " BSP
16	003010	1	. . . Hose tail, $\frac{1}{4}$ " BSPT x $\frac{3}{8}$ " hose
17	011257	1	. Valve, ball type, F/F, $\frac{1}{4}$ " BSP Page 98
	011152	1	. . Seal, Dowty, $\frac{1}{4}$ " BSP
18	011269	1	. . . Adaptor, bulkhead, M/M, $\frac{1}{4}$ " BSP
19	012548	1 Bracket, valve mounting
	011031	1 Setscrew, M10 x 25mm
	011075	1 Nut, M10, Nyloc
	011152	1	. . Seal, Dowty, $\frac{1}{4}$ " BSP
20	027188	1	. . . Adaptor, restrictor 0.6mm, $\frac{1}{4}$ " BSP, M/M (Green)
21	011171	1 Elbow, swivel, F/F, $\frac{1}{4}$ " BSP
22	003010	1 Hose tail, $\frac{1}{4}$ " BSPT x $\frac{3}{8}$ " hose

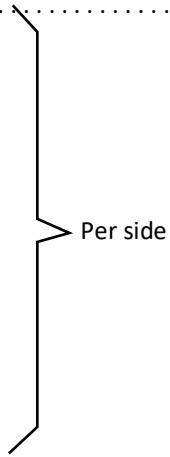

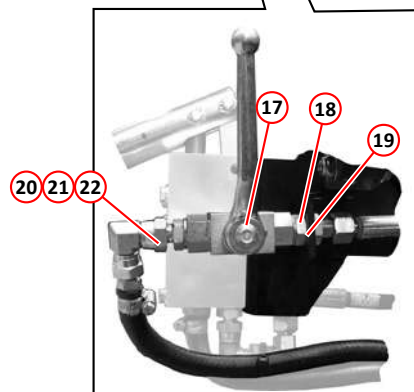
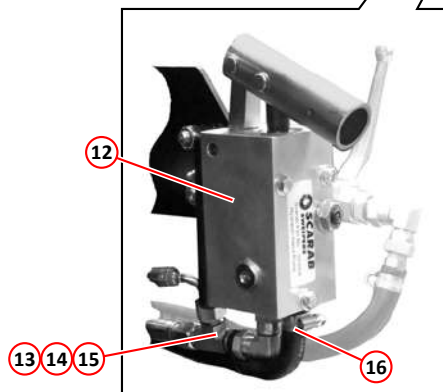
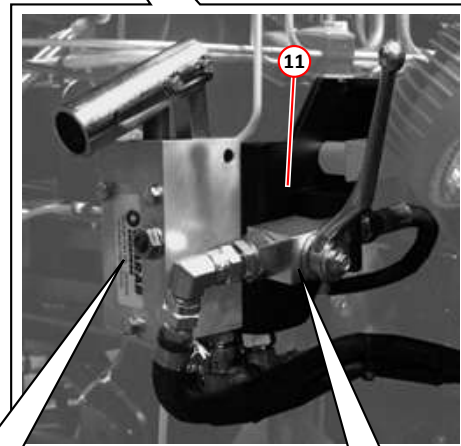
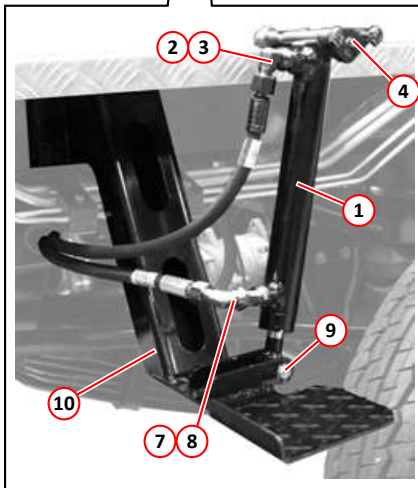
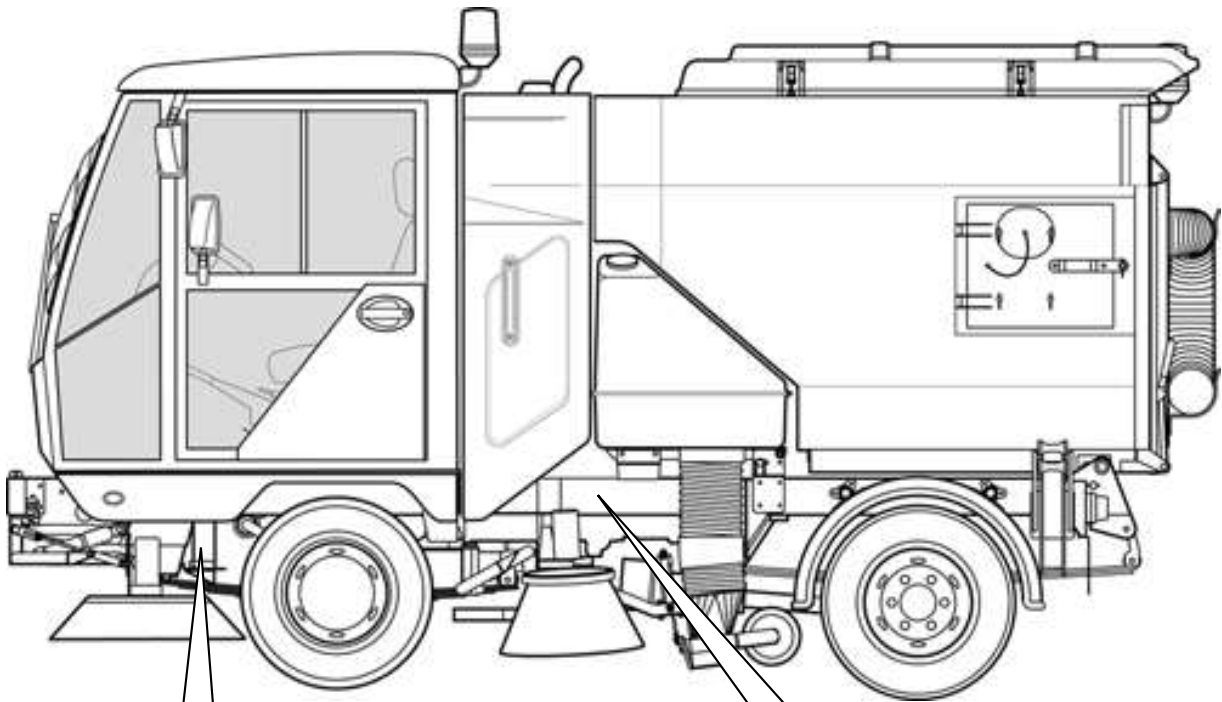

HYDRAULICALLY ASSISTED CAB TILT (OPTION)

Item	Part Number	Quantity	Description
Hydraulically Assisted Cab Tilt - Circuit Components			
1		1	Hydraulic oil tank Page 194
2	025148	1	Manifold, oil return Page 192
3	010958	AR	. Pipe, rubber, $\frac{3}{8}$ " bore
	010516	2	. . Clamp, worm drive, 11-16mm
4	010910	2	. Tee, galvanised, F/F/F, $\frac{1}{4}$ " BSP
5	010944	1	. Adaptor, galvanised, M/M, $\frac{1}{4}$ " BSP
6	010909	2	. Elbow, galvanised, M/F, $\frac{1}{4}$ " BSP
7	010922	2	. Hose tail, $\frac{1}{4}$ " BSP x $\frac{3}{8}$ " hose
8	010958	AR	. Pipe, rubber, $\frac{3}{8}$ " bore
	010516	2	. . Clamp, worm drive, 11-16mm
9	001103	1	. Hose, rubber, $\frac{1}{4}$ " BSP x 256mm straight and 90° ends
10	010958	AR	. Pipe, rubber, $\frac{3}{8}$ " bore
	010516	2	. . Clamp, worm drive, 11-16mm
11	011257	1	. Valve, ball type, F/F, $\frac{1}{4}$ " BSP Page 96
12	023006	1	. Pump, hand Page 96
13	010985	1	. Hose, rubber, $\frac{1}{4}$ " BSP x 2150mm, straight ends
14	010981	2	. Hose, rubber, $\frac{1}{4}$ " x 711mm, straight ends
15	011180	1	. . Tee, M/M/M, $\frac{1}{4}$ " BSP
16	032810	2	. Hydraulic ram, double acting Page 96,12204
17	001062	2	. Hose, rubber, $\frac{1}{4}$ " BSP x 850mm, straight ends
18	011158	2	. . Adaptor, M/M, $\frac{1}{4}$ " BSP

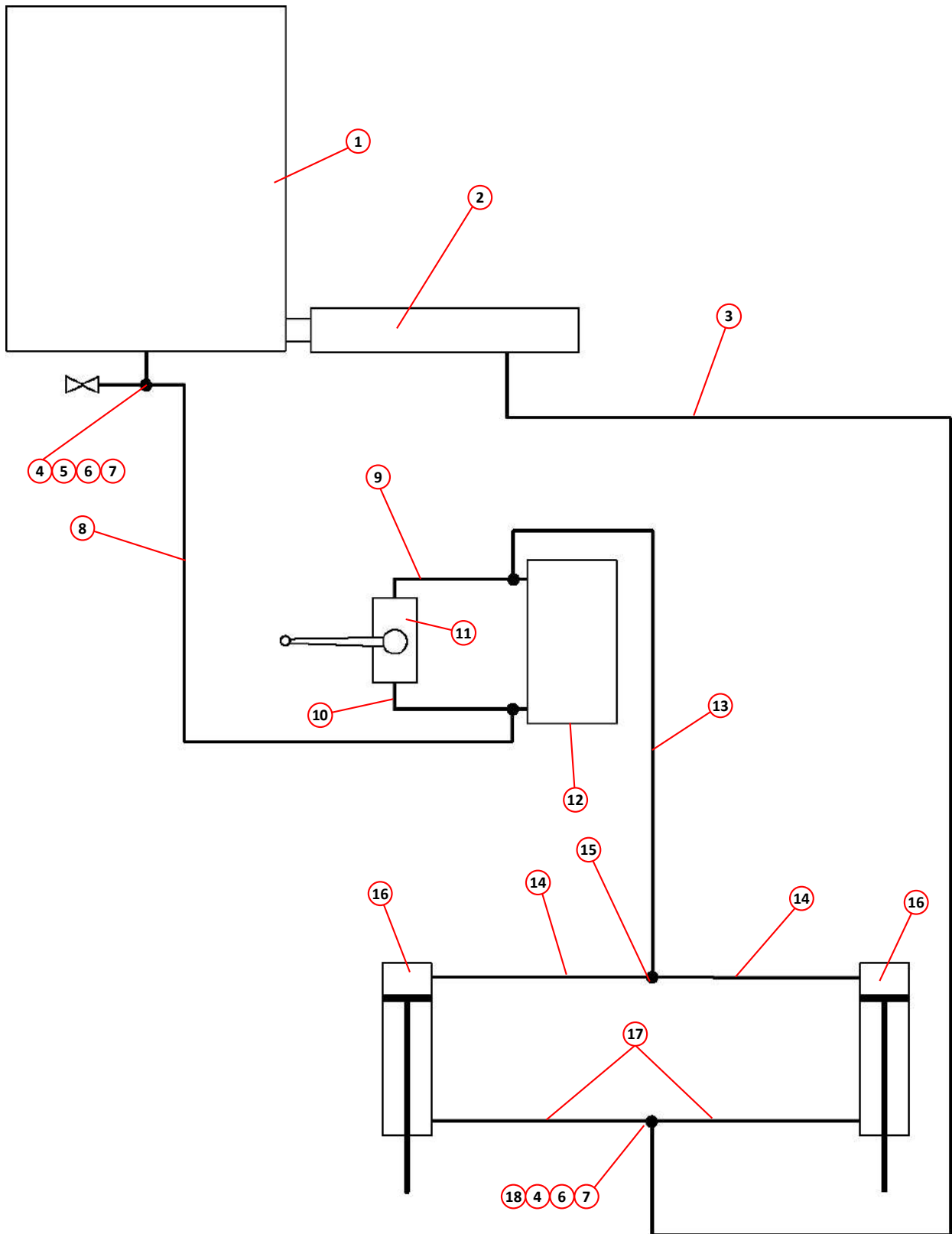

HYDRAULICALLY ASSISTED CAB-TILT
CIRCUIT COMPONENTS

Item	Part Number	Quantity	Description
Cab Heater and Optional Air Conditioning Arrangement			
1	031777		Kit, heater assembly, standard Page 88
1a	031776		Kit, heater, with air conditioning modification
2	027710		Bowden cable
3	031844		Valve, heater control,
4	000396		Retainer, push on, $\frac{3}{16}$ " shaft (for valve/heater cable)
NI	031867	1	Blanking plate, heater

Item	Part Number	Quantity	Description
Air Conditioning Compressor Arrangement			
1	027715	1	Compressor unit
2	040860*	1	. Carrier, compressor unit
NI	039932*	4	. . Flex-Loc, anti vibration, fastener, M8
3	040859	1	. . Upper cover
4	040856	1	. . Lower cover (with Air Con)
NI	040863	1	. . Lower cover (without Air Con)
5	040858	1	. . Bracket, upper cover and lifting eye
6	040857	1	. . Support, upper cover
NI	040864	1	. . Bracket, lower cover
NI	040865	1	. . Mount, lower cover
NI	040868	AR	. . Flex-Loc, anti vibration, fastener, M6
7	025587	1	. . V Belt, A29
8	032704	1	. . Pulley
NI	033893	1	. . Pulley (VM Engine)
NI	031633	1	Control panel (Cab) Page 86

Notes:-

* If the carrier to be replaced has hank nuts then ensure you ask for the anti vibration fasteners when ordering the carrier.

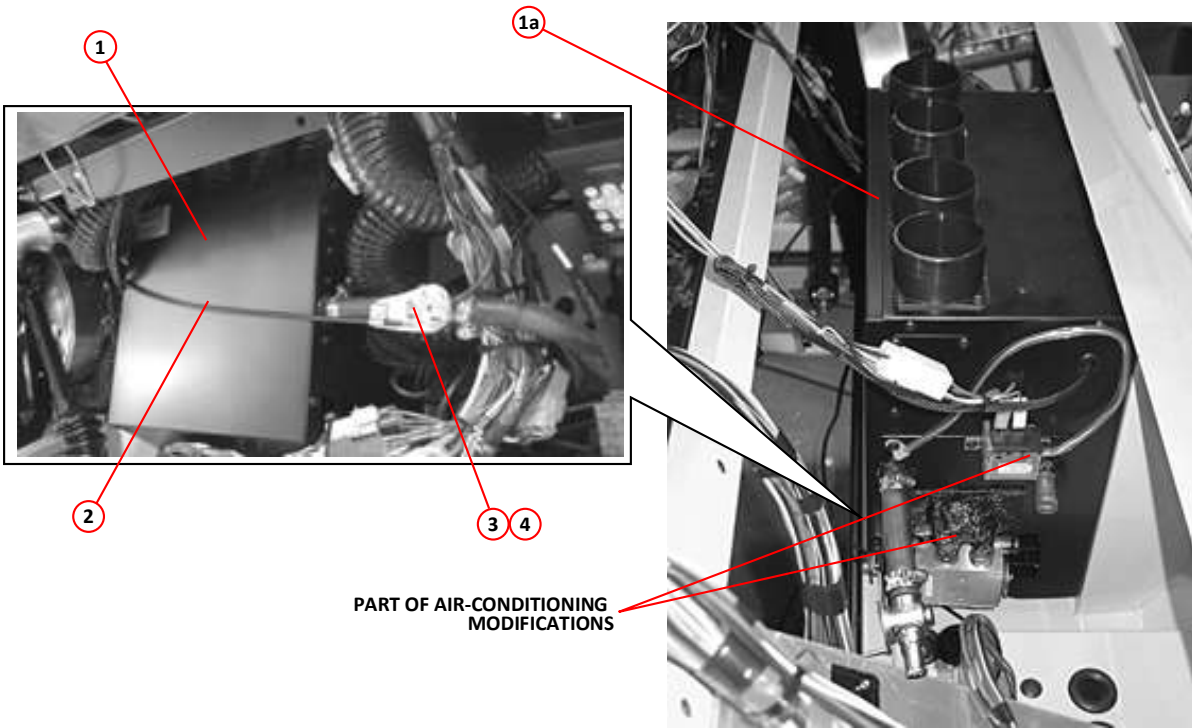

PART OF AIR-CONDITIONING MODIFICATIONS

CAB HEATER ASSEMBLY

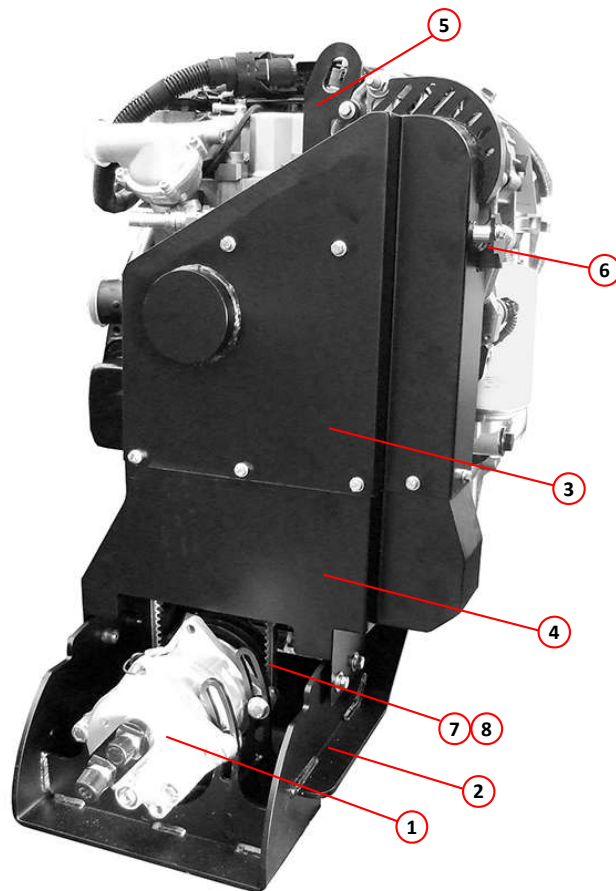

AIR CONDITIONING COMPRESSOR ARRANGEMENT

Item	Part Number	Quantity	Description
Air Conditioning Condenser/Radiator Arrangement			
1	028977	1	Condenser/radiator
2	033853	1	. Cradle, condenser/radiator
	011011	2	. . Setscrew, M8 x 25mm
	011092	2	. . Washer, M8
NI	033855	2	. . Spacer, cradle hinge
3	010509	2	. Toggle fastener
	000161	4	. . Screw, countersunk slot head, 2BA x $\frac{1}{2}$ "
	011078	4	. . Nut, 2BA, Nyloc
4	021841	2	. Hook, toggle fastener
	000161	4	. . Screw, countersunk slot head, 2BA x $\frac{1}{2}$ "
	011078	4	. . Nut, 2BA, Nyloc
5	032886	2	. Clamp, upper, condenser
	011090	4	. . Washer, M6, plain
	011071	4	. . Nut, M6, Nyloc
6	033854	2	. Bracket, hinged, cradle
	011001	8	. . Setscrew, M6 x 20mm
7	028976	1	Receiver drier (black can)
	011067	2	. Setscrew, M6 x 20mm
	011090	2	. Washer, M6
8	034659	1	. Bracket, receiver drier
	011087	2	. Setscrew, M6 x 25mm
	011090	2	. Washer, M6
NI	033997	1	Wiring loom - Condenser/Radiator Page 222

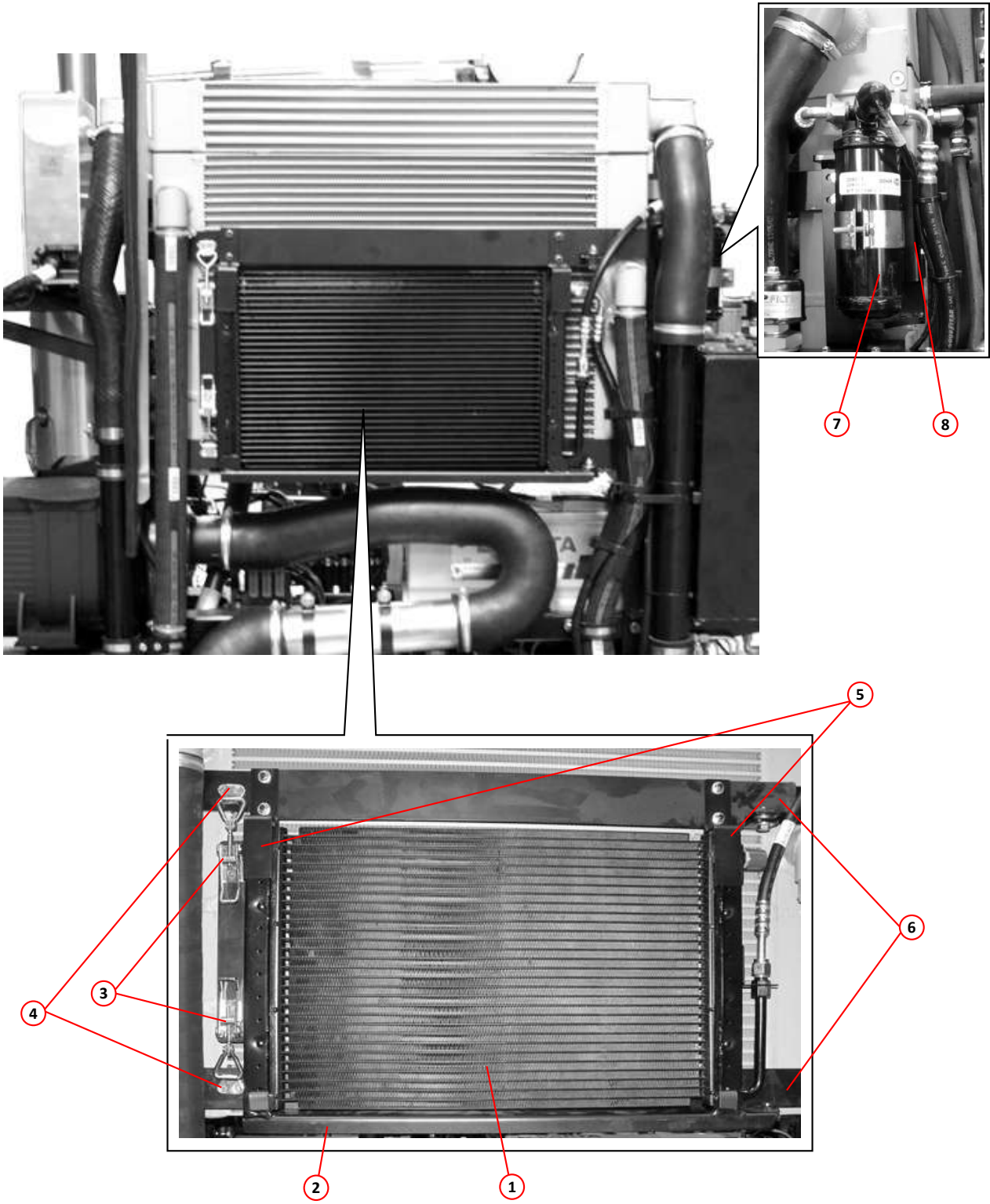

AIR CONDITIONING-RADIATOR ARRANGEMENT

Sweeping and Suction System

<i>Assembly/Description</i>	<i>Page</i>
Wide Sweep Arrangement - Left Hand Single Sweep Machines.....	106
Wide Sweep Arrangement - Right Hand Single Sweep Machines	108
Wide Sweep Arrangement - Dual Sweep Machines	110
Wide Sweep Lifting Arrangement	112
Front Brush Arrangement	114
Front Brush Swing Out and Fixed Arrangement.....	116
Side Brush Arrangement	118
Side Brush Swing Out Arrangement	120
Suction Nozzle Arrangement.....	122
Suction Nozzle Lifting Arrangement	124
Standard Wander Hose Assembly.....	124
Overhead Boom Arrangement	126

Item	Part Number	Quantity	Description
Wide Sweep Arrangement - Left Hand Single Sweep Machines			
1	023253	1	Brush cover
2	010248	1	Tensioner, complete with nuts and washers
3	011030	10	Setscrew, M10 x 20mm
4	011075	10	Nut, M10, Nyloc
5	030680	1	Brush bar
NI	010606	2	Carabiner
NI	010525	AR	Chain link
6	023252	1	Tow bar, left hand single sweep
7	011052	2	Setscrew, M12 x 25mm
8	023346	1	Tow bar support bracket, left side Page 42
9	010689	2	Bush
10	011077	2	Nut, M12, Nyloc
11	023347	1	Tow bar support bracket, right side Page 42
12	011031	4	Setscrew, M10 x 25mm
13	011075	4	Nut, M10, Nyloc
14	011405	2	Nut, $\frac{3}{8}$ " UNF, Nyloc
15	011031	1	Setscrew, M10 x 25mm
16	012548	2	Bracket, mounting, shock absorber
17	011075	6	Nut, M10, Nyloc
18	012524	2	Shock absorber
19	011035	3	Setscrew, M10 x 50mm
20	027156	1	Spacer, hex
22	010682	2	End plate
23	011030	4	Setscrew, M10 x 20mm
24	011075	4	Nut, M10, Nyloc
25	010749	1	Motor, brush drive, hydraulic, OMP200 Page 198
NI	040058*	1	Spacer
26	011053	2	Setscrew, M12 x 35mm
27	011077	2	Nut, M12, Nyloc
28	011167	2	Adaptor, M/M, $\frac{1}{2}$ " x $\frac{3}{8}$ " BSP
29	011154	2	Seal, Dowty, $\frac{1}{2}$ " BSP
30	010612	1	Bearing, complete with locking collar
31	005052	1	Grease point
32	011053	2	Setscrew, M12 x 35mm
33	011077	2	Nut, M12, Nyloc
34	011030	5	Setscrew, M10 x 20mm
35	022363	1	Clamp, dust skirt
36	022652	1	Dust skirt
37	022362	1	Hanger, dust skirt
38	011075	5	Nut, M10, Nyloc
39	013648	1	Shaft, brush drive
40	013647	1	Brush core
41	023471	28	Brush disc refill, Polypropylene
42	023472	27	Spacer ring, brush disc
43	013649	1	End cap, brush core
44	011417	4	Screw, socket countersunk, $\frac{3}{8}$ " UNC x 1"
45	013652	1	Tube, brush drive

Notes:-

* This part is required if the drive motor is manufactured by Eaton, please contact Scarab Parts Department.

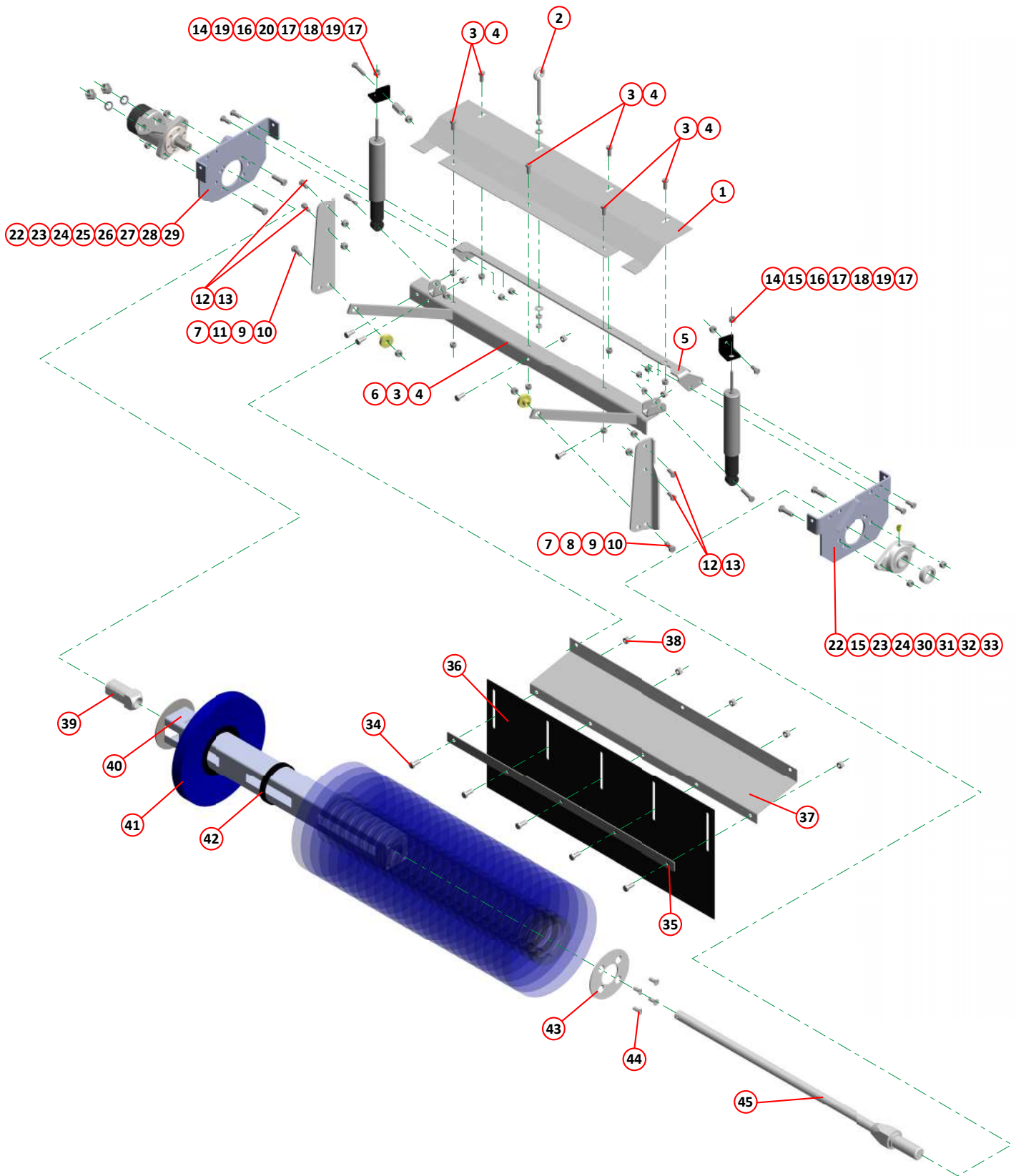

WIDE SWEEP ARRANGEMENT - LEFT HAND SINGLE SWEEP MACHINES

Item	Part Number	Quantity	Description
Wide Sweep Arrangement - Right Hand Single Sweep Machines			
1	023253	1	Brush cover
2	010248	1	Tensioner, complete with nuts and washers
3	011030	10	Setscrew, M10 x 20mm
4	011075	10	Nut, M10, Nyloc
5	030680	1	Brush bar
NI	010606	2	Carabiner
NI	010525	AR	Chain link
6	023252	1	Tow bar, left hand single sweep
7	011052	2	Setscrew, M12 x 25mm
8	023346	1	Tow bar support bracket, left side Page 42
9	010689	2	Bush
10	011077	2	Nut, M12, Nyloc
11	023347	1	Tow bar support bracket, right side Page 42
12	011031	4	Setscrew, M10 x 25mm
13	011075	4	Nut, M10, Nyloc
14	011405	2	Nut, $\frac{3}{8}$ " UNF, Nyloc
15	011031	1	Setscrew, M10 x 25mm
16	012548	2	Bracket, mounting, shock absorber
17	011075	6	Nut, M10, Nyloc
18	012524	2	Shock absorber
19	011035	3	Setscrew, M10 x 50mm
20	027156	1	Spacer, hex
22	010682	2	End plate
23	011030	4	Setscrew, M10 x 20mm
24	011075	4	Nut, M10, Nyloc
25	010749	1	Motor, brush drive, hydraulic, OMP200 Page 198
NI	040058*	1	Spacer
26	011053	2	Setscrew, M12 x 35mm
27	011077	2	Nut, M12, Nyloc
28	011167	2	Adaptor, M/M, $\frac{1}{2}$ " x $\frac{3}{8}$ " BSP
29	011154	2	Seal, Dowty, $\frac{1}{2}$ " BSP
30	010612	1	Bearing, complete with locking collar
31	005052	1	Grease point
32	011053	2	Setscrew, M12 x 35mm
33	011077	2	Nut, M12, Nyloc
34	011030	5	Setscrew, M10 x 20mm
35	022363	1	Clamp, dust skirt
36	022652	1	Dust skirt
37	022362	1	Hanger, dust skirt
38	011075	5	Nut, M10, Nyloc
39	013648	1	Shaft, brush drive
40	013647	1	Brush core
41	023471	28	Brush disc refill, Polypropylene
42	023472	27	Spacer ring, brush disc
43	013649	1	End cap, brush core
44	013652	1	Tube, brush drive
45	011417	4	Screw, socket countersunk, $\frac{3}{8}$ " UNC x 1"

Notes:-

* This part is required if the drive motor is manufactured by Eaton, please contact Scarab Parts Department.

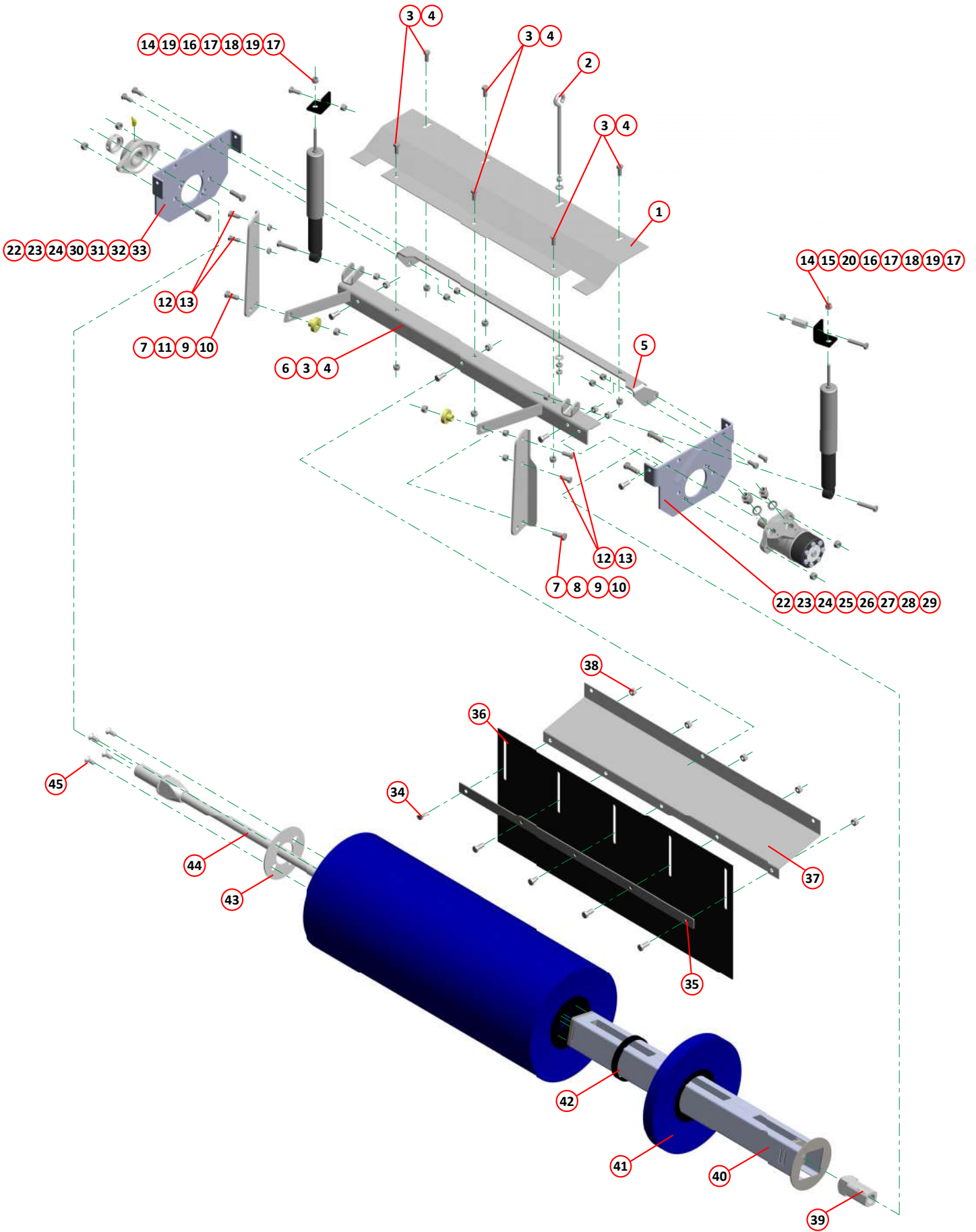

WIDE SWEEP ARRANGEMENT - RIGHT HAND SINGLE SWEEP MACHINES

Item	Part Number	Quantity	Description
Wide Sweep Arrangement - Dual Sweep Machines			
1	030998	1	Brush cover LH
NI	023529	1	Brush cover RH
2	010248	1	Tensioner, complete with nuts and washers
3	011030	9	Setscrew, M10 x 20mm
4	011075	9	Nut, M10, Nyloc
5	030681	1	Brush bar
NI	010606	2	Carabiner
NI	010525	AR	Chain link
6	025609	1	Tow bar, left hand dual sweep Page 42
6	023531	1	Tow bar, right hand dual sweep Page 42
7	011052	2	Setscrew, M12 x 25mm
8	023346	1	Tow bar support bracket, left side Page 42
9	010689	2	Bush
10	011077	2	Nut, M12, Nyloc
11	023347	1	Tow bar support bracket, right side Page 42
12	011031	4	Setscrew, M10 x 25mm
13	011075	4	Nut, M10, Nyloc
14	011405	2	Nut, $\frac{3}{8}$ " UNF, Nyloc
15	011031	1	Setscrew, M10 x 25mm
16	012548	1	Mounting bracket, shock absorber, right hand side
17	025327	1	Mounting bracket, shock absorber, left hand side
18	011075	6	Nut, M10, Nyloc
19	012524	2	Shock absorber
20	011035	3	Setscrew, M10 x 50mm
21	010682	2	End plate
22	011030	4	Setscrew, M10 x 20mm
23	011075	4	Nut, M10, Nyloc
24	023503	1	Motor, brush drive, hydraulic, OMPW200 Page 198
NI	040058*	1	Spacer
25	011031	4	Setscrew, 10 x 25mm
26	011095	4	Spring washer, M10
27	011167	2	Adaptor, M/M, $\frac{1}{2}$ " x $\frac{3}{8}$ " BSP
28	011154	2	Seal, Dowty, $\frac{1}{2}$ " BSP
29	011241	1	Plug, $\frac{1}{4}$ " BSP
30	011150	2	Seal, Dowty, $\frac{1}{4}$ " BSP
31	010612	1	Bearing, complete with locking collar
32	005052	1	Grease point
33	011053	2	Setscrew, M12 x 35mm
34	011077	2	Nut, M12, Nyloc
35	011030	5	Setscrew, M10 x 20mm
36	023533	1	Clamp, dust skirt
37	022652	1	Dust skirt
38	023534	1	Hanger, dust skirt
39	011075	5	Nut, M10, Nyloc
40	013648	1	Shaft, brush drive
41	023528	1	Brush core
42	023471	25	Brush disc refill, Polypropylene
43	023472	24	Spacer ring, brush disc
44	013649	1	End cap, brush core
45	011417	4	Screw, socket countersunk, $\frac{3}{8}$ " UNC x 1"
46	023526	1	Tube, brush drive

Notes:-

* This part is required if the drive motor is manufactured by Eaton, please contact Scarab Parts Department.

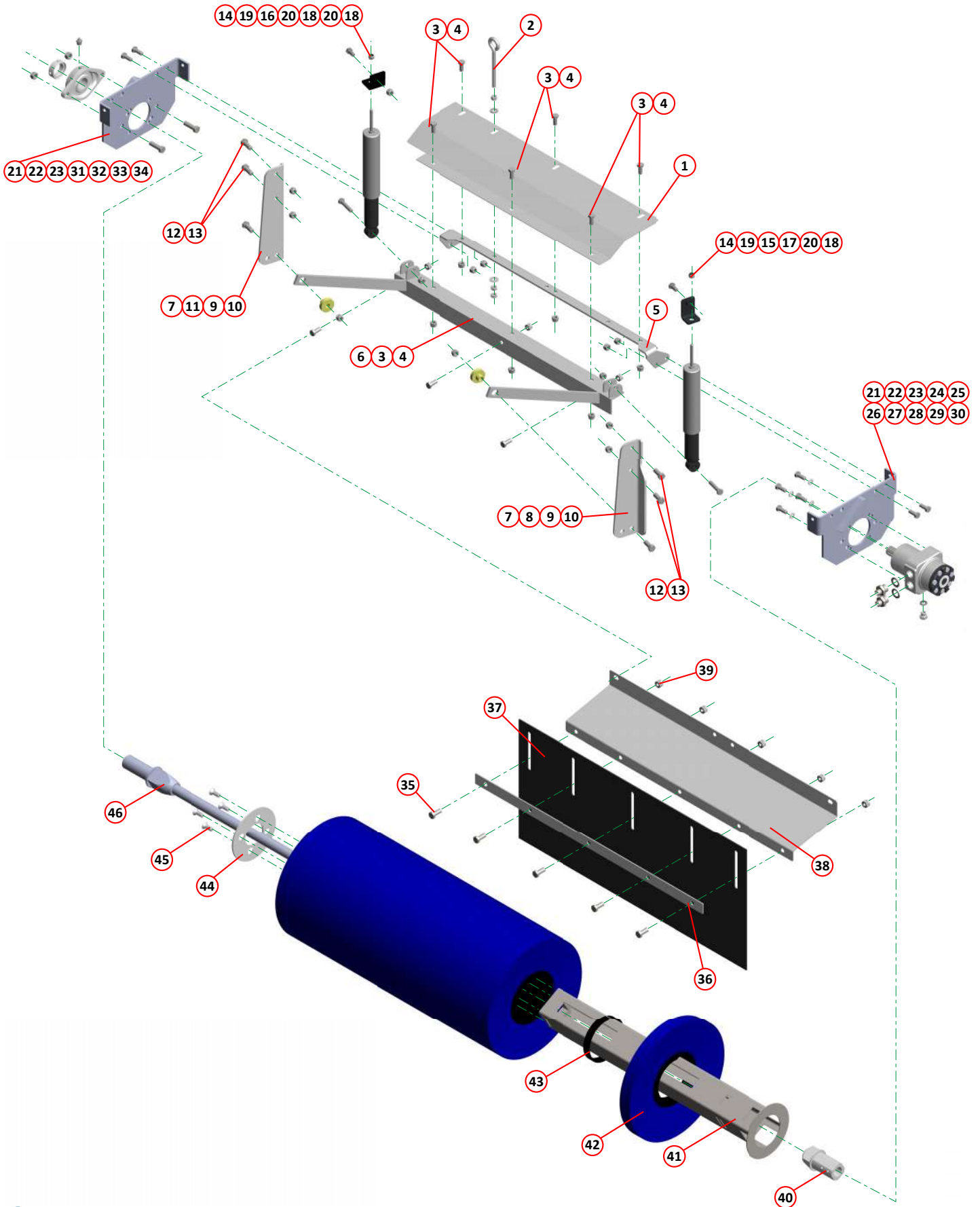

i Left hand dual sweep version illustrated, right hand dual sweep similar.

WIDE SWEEP ARRANGEMENT - DUAL SWEEP MACHINES

Item	Part Number	Quantity	Description
Wide Sweep Lifting Arrangement			
1	013855	1	Bracket, hydraulic ram
	011011	2	. Setscrew, M8 x 25mm
	011073	2	. Nut, M8, Nyloc
2	027115	1	. Ram, hydraulic Page 200
NI	011629	1	. . Seal kit, ram
3	021510	1	. . Bellows
4	010067	1	. . Pin, drilled, ram anchoring
	011102	2	. . . Washer, M20
	011122	2	. . . Pin, split, cotter, $\frac{3}{16}$ " x $1\frac{1}{2}$ "
5	010067	1	. . Pin, drilled, ram/brush link connecting
	011102	2	. . . Washer, M20
	011122	2	. . . Pin, split, cotter, $\frac{3}{16}$ " x $1\frac{1}{2}$ "
6	013853	1	. Bracket, wide sweep lift Page 44
	011011	4	. . Setscrew, M8 x 25mm
	011073	4	. . Nut, M8, Nyloc
7	014231	1	. . Link, brush lift, RH
8	013854	1	. . Link, brush lift, LH
	011102	2	. . . Washer, M20
	011122	1	. . . Pin, split, cotter, $\frac{3}{16}$ " x $1\frac{1}{2}$ "

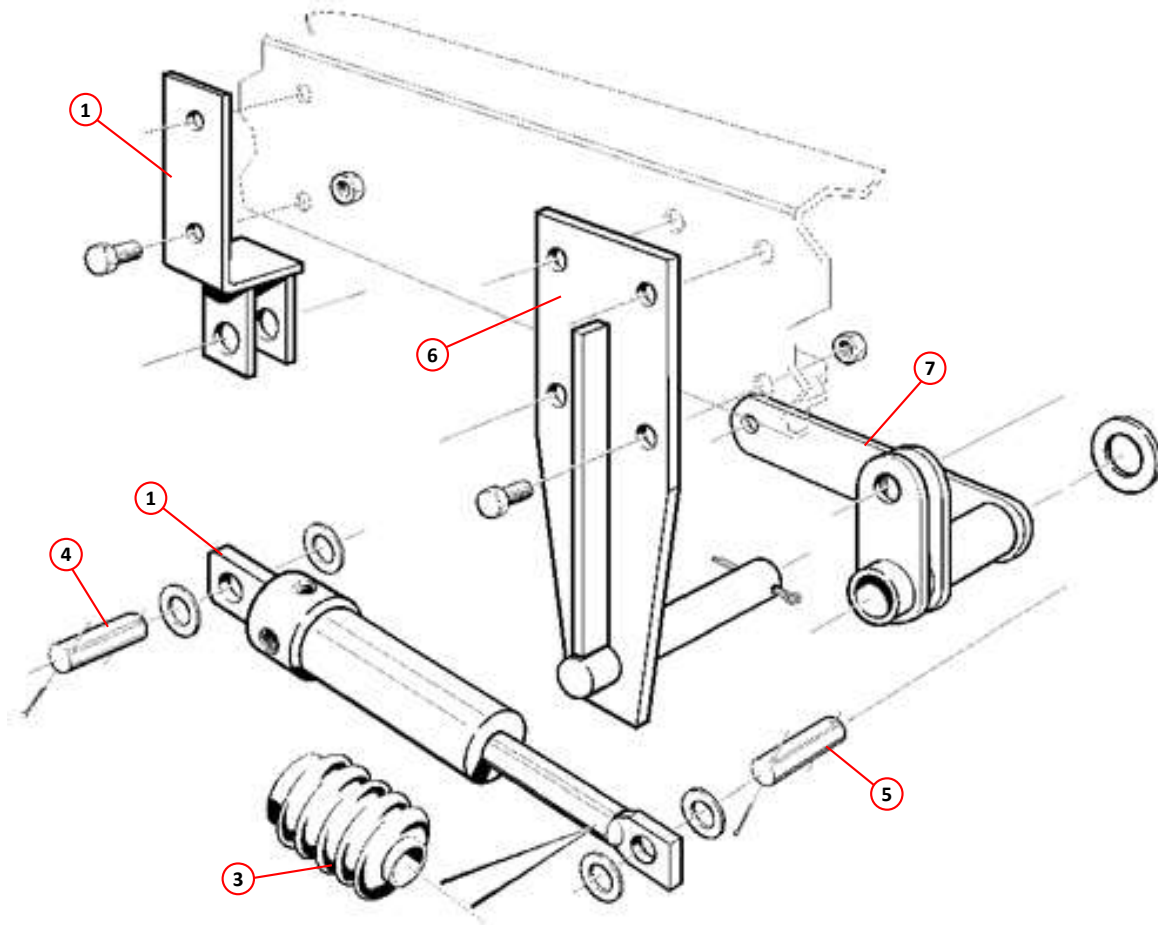

RH Sweep Assembly Illustrated, LH Assembly Similar

WIDE SWEEP LIFTING ARRANGEMENT

Item	Part Number	Quantity	Description
Front Brush Arrangement			
1	013492	1	Pivot block, brush
2	013487	1	. Top link, (turnbuckle)
3	020564	1	. . Spacer, $\varnothing 25\text{mm}$ O/D x $\varnothing 16.5\text{mm}$ I/D x 14mm
4	014129	1	. . Spacer, spring anchor
5	013332	1	. . Bracket, spring anchor
	011133	1	. . . Bolt, M16 x 100mm
	011060	1	. . . Nut, M16, Nyloc
6	020564	1	. . Spacer, $\varnothing 25\text{mm}$ O/D x $\varnothing 16.5\text{mm}$ I/D x 25mm
NI	013493	1	. . Spacer, ram sleeve, $\varnothing 20\text{mm}$ O/D x $\varnothing 16.5\text{mm}$ I/D x 11.3mm
7	020565	1	. . Spacer, $\varnothing 25\text{mm}$ O/D x $\varnothing 16.5\text{mm}$ I/D x 22mm
	011423	1	. . . Bolt, M16 x 110mm
	011060	1	. . . Nut, M16, Nyloc
8	010248	1	. Tensioner (with lock nuts)
9	010521	2	. . Spring, 6
	011077	1	. . . Nut, M12, Nyloc
	011096	2	. . . Washer, M12
10	013494	1	. Link, brush
11	013489	1	. Plate, swivel
12	013488	4	. . Bush
13	034819	2	. . Sleeve
14	010903	1	. . Grease point, straight, $\frac{1}{4}$ " BSP
15	010901	1	. . . Grease point, 135° , $\frac{1}{8}$ " BSP
16	011259	2	. . . Bolt, M12 x 130mm
17	011077	2	. . . Nut, M12, Nyloc
18	027116	1	. Ram, hydraulic, front brush lift Page 202
19	010067	1	. . Pin, Drilled, $\varnothing 20\text{mm}$ x 50mm
	011122	2	. . Pin, split, $\frac{3}{16}$ x $1\frac{1}{2}$
20	010006	1	. Motor, brush drive, hydraulic, OMP315 Page 198
	011069	2	. . Bolt, M12 x 40mm
	011077	1	. . Nut, M12, Nyloc
21	021214	1	. Bracket, motor
	011075	2	. . . Nut, M10, Nyloc
	011094	2	. . . Washer, M10
22	024139	1	. Disc, brush, slotted
NI	040058*	1	. . Spacer, brush hub
	040197	1	. . Washer, safety, Schnorr
	011012	1	. . Screw, M8 x 30mm
	011011	1	. . Setscrew, M8 x 25mm
23	023469	1 Brush, polypropylene, $\varnothing 400\text{mm}$ (with mounting bolts)
	000185	6 Nut, flanged, M8

Notes:-

* This part is required if the drive motor is manufactured by Eaton, please contact Scarab Parts Department.

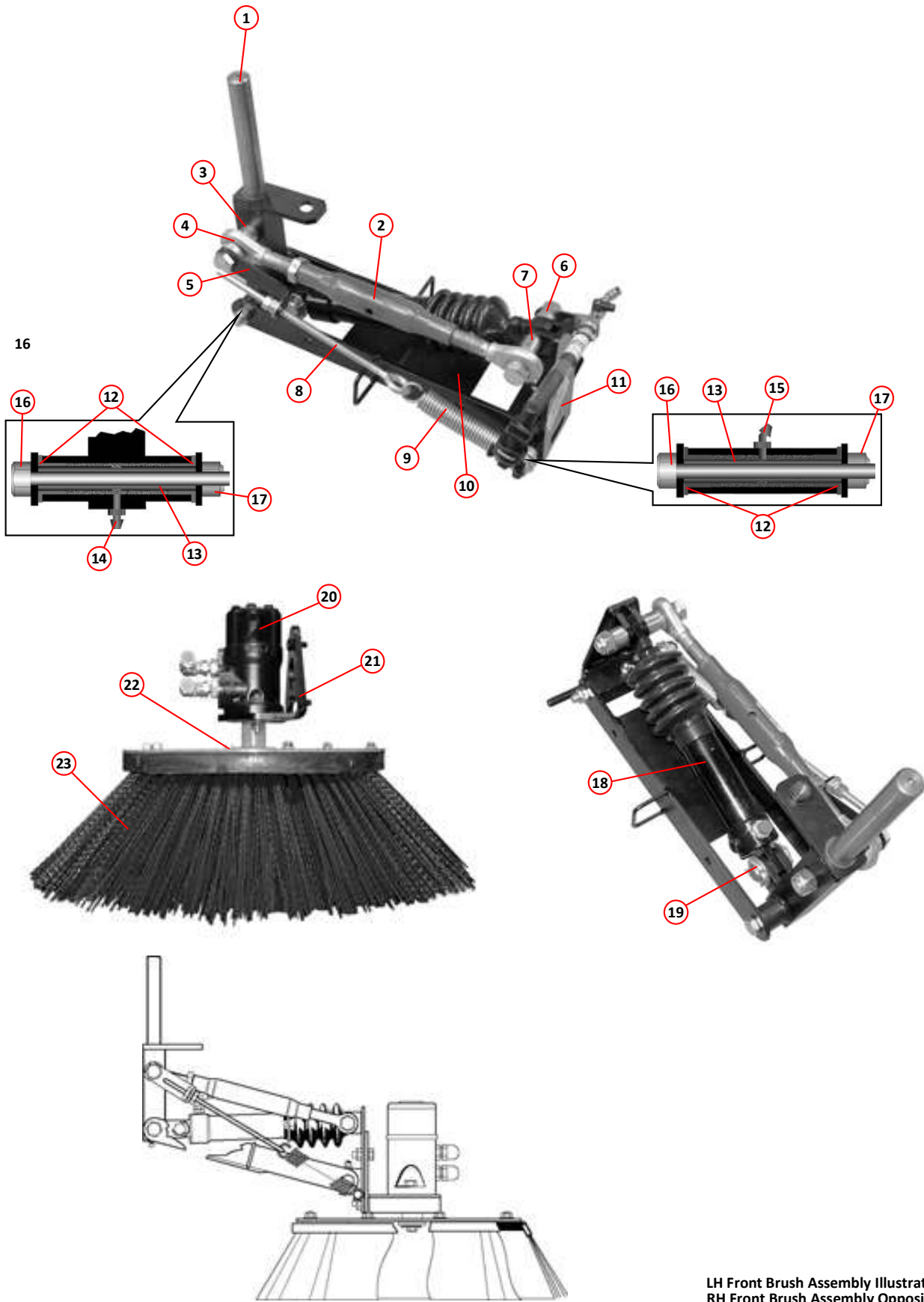

LH Front Brush Assembly Illustrated
RH Front Brush Assembly Opposite

FRONT BRUSH ARRANGEMENT

Item	Part Number	Quantity	Description
Front Brush Swing Out and Fixed Arrangement			
1	040350	AR	Ram, hydraulic, front brush swing out Page 202
2	013497	AR	. Link
	011030	2	. . Setscrew, M10 x 20mm
	011094	2	. . Washer, M10
3	014038	AR	. . Pin, drilled, $\varnothing 20\text{mm}$ O/D x 70mm
	011102	AR	. . Washer, M20
	011122	AR	. . Pin, split, $\varnothing \frac{3}{16}$ " x $1\frac{1}{2}$ "
4	013496	AR	. Lever, pivot
	011262	AR	. . Bolt, M8 x 140mm
	011092	AR	. . Washer, M8
	011073	AR	. . Nut, M8 Nyloc
5	010067	2	. Pin, drilled, $\varnothing 20\text{mm}$ O/D x 50mm long
6	011122	4	. Pin, split, $\varnothing \frac{3}{16}$ " x $1\frac{1}{2}$ "
7	010768	2	. Collar, locking, $\varnothing 1$ " I/D
8	010903	2	. Greasing point, $\frac{1}{8}$ " BSP, straight
9	013662	4	. Bush, brush pivot
10	013486	2	. Strut, stabilising, gas operated
	022484	4	. . Joint, ball, stabilising strut
	011075	2	. . . Nut, M10 Nyloc
11	014904	1	. Link, sliding
	011030	1	. . Setscrew, M10 x 20mm
	010313	1	. . Washer, special, $\varnothing 40\text{mm}$ O/D x $\varnothing 11\text{mm}$ I/D x 5mm
	011095	1	. . Washer, spring, M10

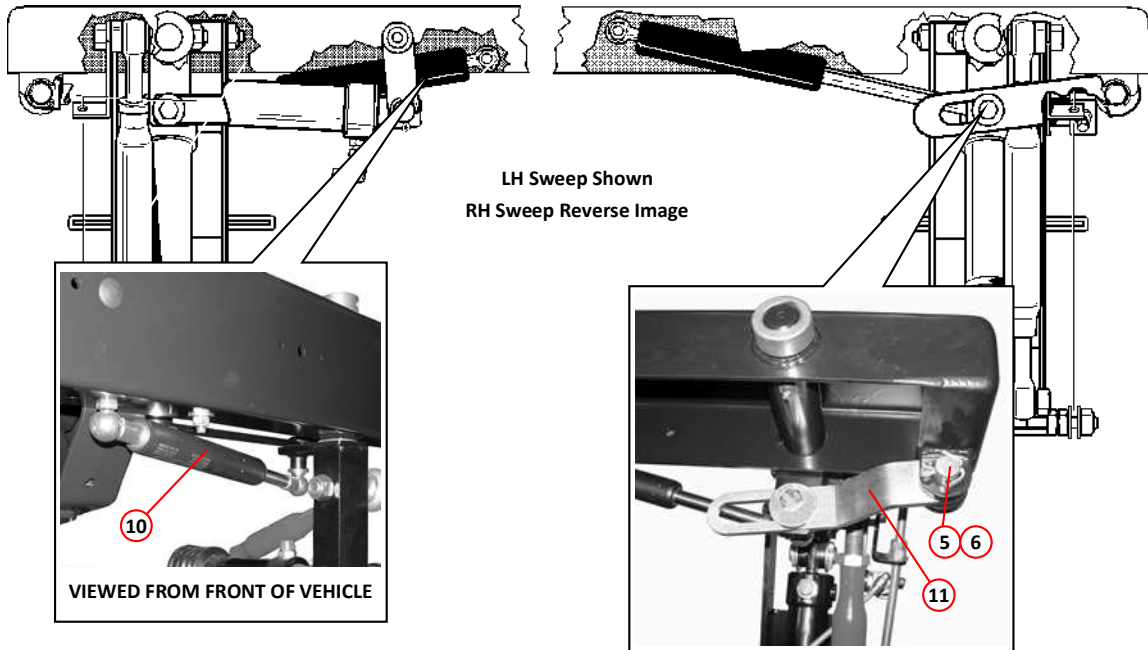
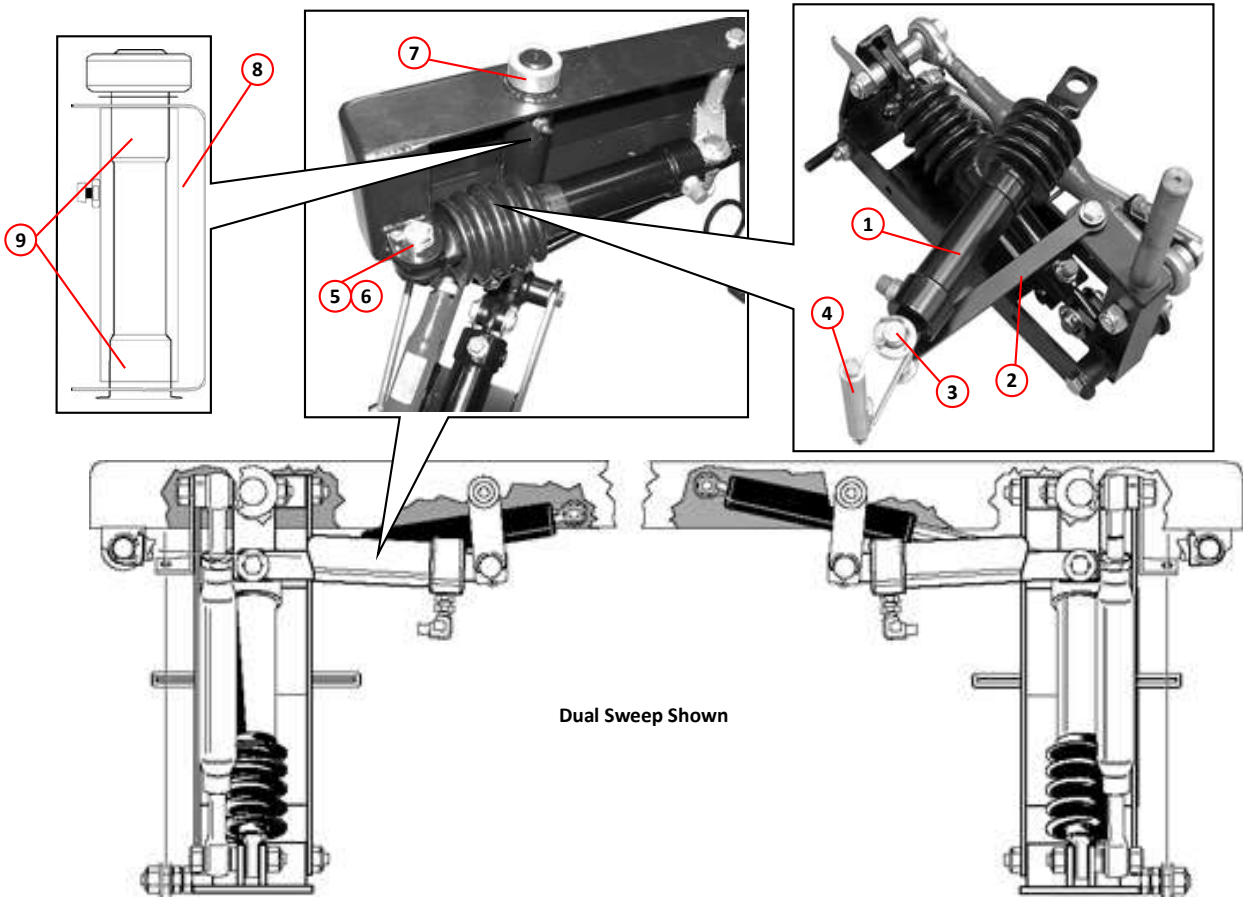

FRONT BRUSH SWING OUT AND FIXED ARRANGEMENT

Item	Part Number	Quantity	Description
Side Brush Arrangement			
1	013484	1	Pivot, brush, LH
NI	014226	1	Pivot, brush, RH
2	013488*	4	. Bush, brush raise
3	013491*	2	. Sleeve, brush raise
4	011259*	3	. Bolt, M12 x 130mm
5	011077*	3	. Nut, M12, Nyloc
6	010903	1	. Greasing point, straight, $\frac{1}{8}$ " BSP
7	013495	1	. . Link, brush raise
8	013489	1	. . Plate, swivel
9	010901	1	. . . Nipple, grease, 135°, $\frac{1}{8}$ " BSP
10	020565	2	. Spacer, \varnothing 25mm O/D x \varnothing 16.5mm I/D x 22mm
NI	013493	1	. . Spacer, ram sleeve, \varnothing 20mm O/D x \varnothing 16.5mm I/D x 11.3mm
11	020564	1	. Spacer, \varnothing 25mm O/D x \varnothing 16.5mm I/D x 25mm
12	013487	1	. Link, top
	011133	1	. . Bolt, M16 x 120mm
	011423	1	. . Bolt, M16 x 110mm
	011060	2	. . Nut, M16, Nyloc
13	027114	1	. Ram, hydraulic, side brush lift Page 202
14	010067	2	. . Pin, Drilled, \varnothing 20mm O/D x 50mm
	011122	4	. . Pin, split, \varnothing $\frac{3}{16}$ x $1\frac{1}{2}$
	011102	2	. . Washer, M20
15	010007	1	. Bracket, brush motor
	011075	2	. . Nut, M10, Nyloc
	011094	2	. . Washer, M10
16	010006	1	. . Motor, hydraulic, OMP315 Page 198
	011069	2	. . . Setscrew, M12 x 40mm
	011077	2	. . . Nut, M12, Nyloc
17	011688	1	. . . Hub, Brush
NI	040058**	1	. . Spacer, brush hub
	040197	1	. . Washer, safety, Schnorr
	011012	1	. . Screw, M8 x 30mm
18	023470	1 Brush, side, steel
19	011011	1 Setscrew, M8 x 25mm
20	010004	1 Washer, special, \varnothing 45mm O/D x \varnothing 9mm I/D x 4mm
21	010005	1 Washer, tab

Notes:-

* Pin and bush kit order part number 024610.

** This part is required if the drive motor is manufactured by Eaton, please contact Scarab Parts Department.

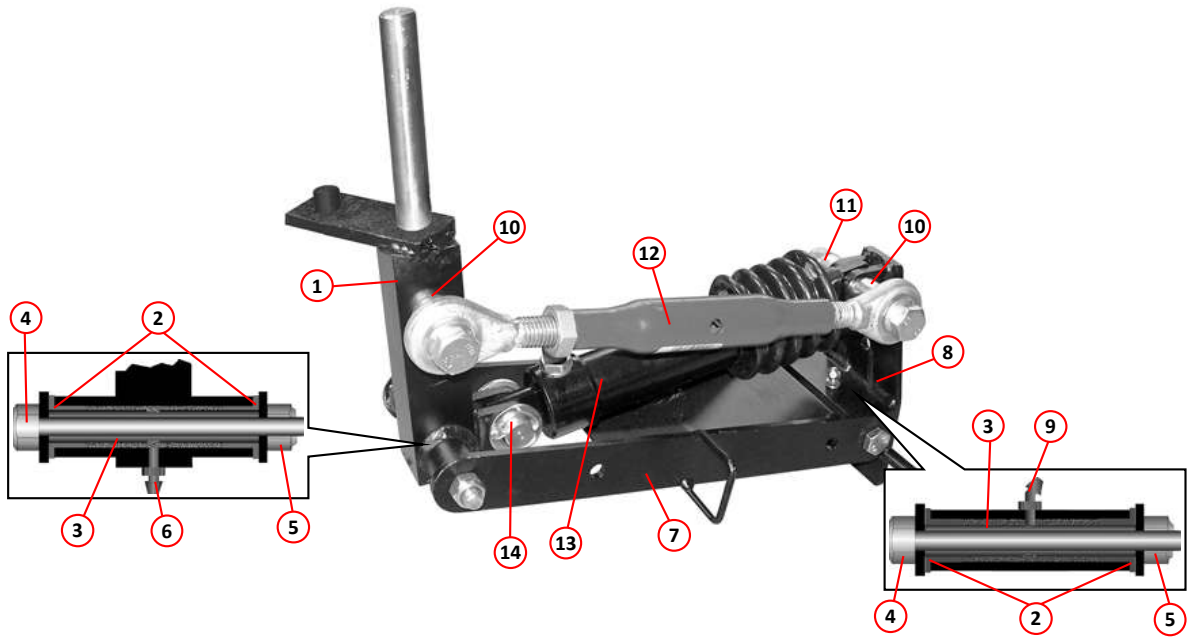

LH Brush Illustrated

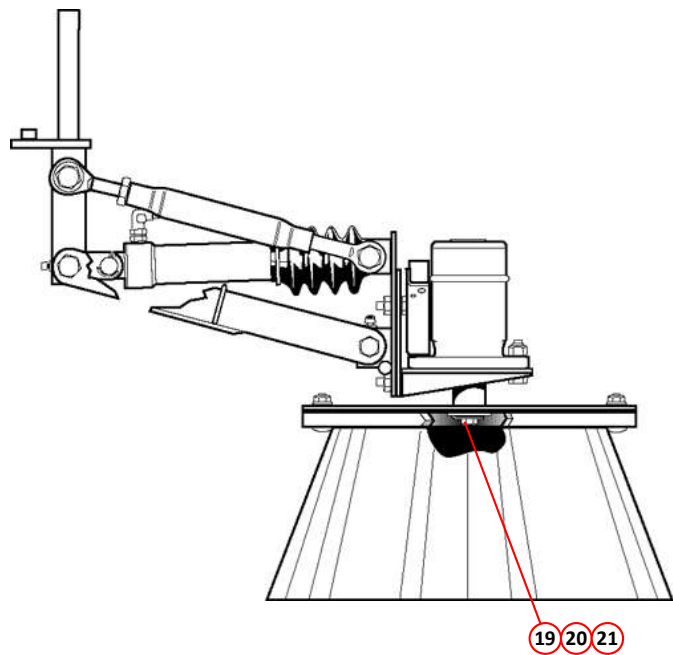

SIDE BRUSH ARRANGEMENT

Item	Part Number	Quantity	Description
Side Brush Swing Out Arrangement			
1	013485	1	Bracket, mounting, side brush, LH
NI	014229	1	Bracket, mounting, side brush, RH
2	022451*	AR	. Spacer, $\phi 20$ mm O/D x $\phi 12.5$ mm I/D x 60mm
	000023	AR	. . Bolt, M10 x 90mm
2A	014508*	AR	. Spacer, $\phi 20$ mm O/D x $\phi 12.5$ mm I/D x 24mm
	011035	AR	. . Setscrew, M10 x 50mm
3	027156*	4	. Spacer, hex
	011031	4	. . Setscrew, M10 x 25mm
4	022484	1	. Ball joint, Strut, stabilising
	011094	2	. . Washer, M10
NI	013486	1	. . Strut, stabilising, gas operated
5	027118	1	. Ram, hydraulic, swing out Page 202
6	010067	2	. Pin, drilled, $\phi 20$ mm O/D x 50mm
	011102	3	. . Washer, M20
	011122	2	. . Pin, split, $\phi \frac{3}{16}$ " x $1\frac{1}{2}$ " long
7	010247	1	. Skirt, rubber
8	014151	1	. . Clamp, skirt
	011011	3	. . . Setscrew, M8 x 25mm
	011073	3	. . . Nut, M8, Nyloc
9	010768	1	. Collar, $\phi 1$ I/D
10	013662	2	. Bush, brush pivot
11	010902	1	. Greasing point, straight, $\frac{1}{8}$ " BSP

Notes:-

- * Dual sweep LH drive. 4 x item 2 per side, 4 x item 3 per side.
- Dual sweep RH drive. 4 x item 2. LH side, 4 x item 2A. RH side, 4 x item 3 per side.
- LH/RH sweep. 4 x item 3, on the appropriate side.

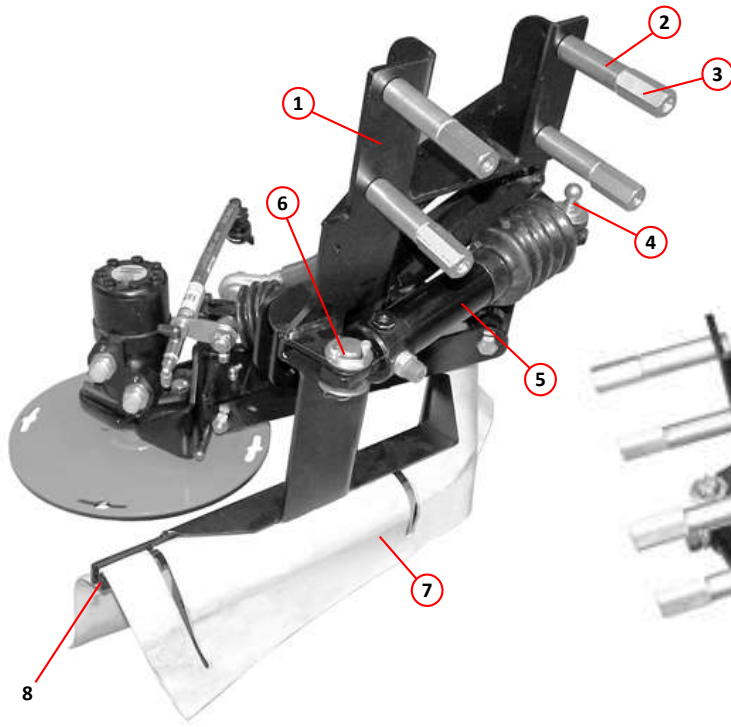

Left Hand



Right Hand

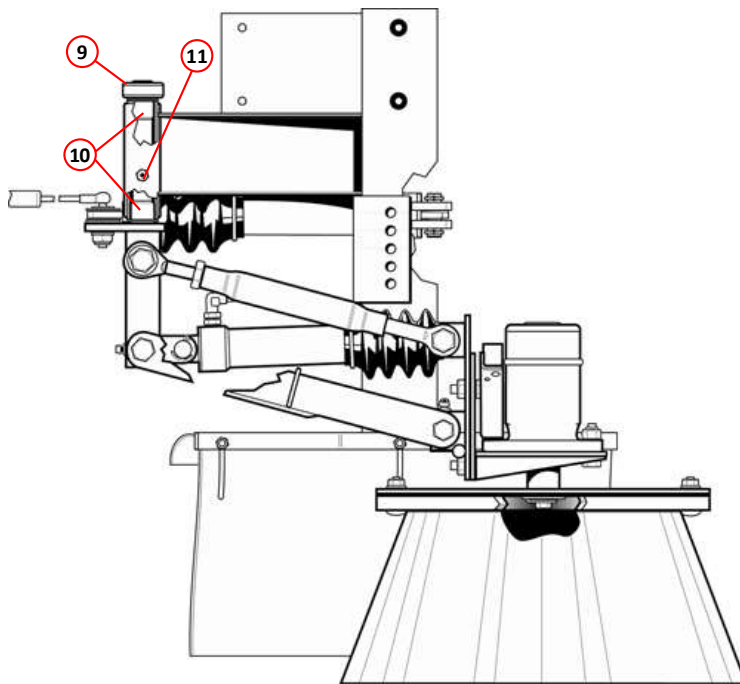

LH Dual Sweep Illustrated

SIDE BRUSH SWING OUT ARRANGEMENT

Item	Part Number	Quantity	Description
Suction Nozzle Arrangement			
1	018207*	1	Suction nozzle, complete assembly, LH
NI	023279*	1	Suction nozzle, complete assembly, RH
2	041186**	1	Suction nozzle, complete assembly, LH
NI	041187**	1	Suction nozzle, complete assembly, RH
3	013902	1	. Carrier, nozzle
	011054	1	. . Setscrew, M12 x 45mm
	011077	1	. . Nut, M12, Nyloc
4	013398	1	. Box, suction nozzle
	000129	4	. . Screw, socket countersunk, M8 x 25mm
NI	023154	1	. Rubber suction hose
NI	014303	1	. Suction tube
	011073	4	. . Nut, M8, Nyloc
5	010525	2	. . Chain, nozzle lift, 8 links in length
6	010606	1	. . . Carabiner
7	013115	2	. Wheel, suction nozzle
	011105	1	. . . Bolt, M12 x 120mm
	011096	3	. . . Washer, M12
	011077	1	. . . Nut, M12, Nyloc
8	013903	1	. Frame, nozzle tilt
9	011592	1	. . Clamp, nozzle flap (rear)
	011011	4	. . . Setscrew, M8 x 25mm
10	013615	2	. . Clamp, nozzle flap (side)
	011011	2	. . . Setscrew, M8 x 25mm
11	011593	1 set	. Nozzle flap, rubber (comprising 1 front, 1 rear, 2 side)
12	011592	1	. . Clamp, nozzle flap (front)
	011073	4	. . .Nut, M8, Nyloc
13	011811	1	. Rod, nozzle tilt
	011092	1	. . Washer, M8
	011072	2	. . Nut, M8
	011073	1	. . Nut, M8, Nyloc
	011042	1	. . Bolt, M10 x 110mm
	011094	4	. . Washer, M10
	011075	1	. . Nut, M10, Nyloc
14	027113	1	. Ram, hydraulic, suction nozzle tilt Page 200
NI	011629	1	. . Seal, ram, repair kit
	011036	2	. . Bolt, M10 x 60mm
	011075	2	. . Nut, M10, Nyloc
15	010521	1	. Spring, coil, nozzle tilt
	011038	1	. . Bolt, M10 x 80mm
	011094	13	. . Washer, M10, (to space-out between carrier and spring)
16	034342	3	. Nozzle assembly, water spray Page 150
	011001	3	. Setscrew, M6 x 16mm
	011091	3	. Washer, spring, M6
17	024647	AR	. Tee, plastic, 6mm, push fit
NI	035733	AR	. . Tube, plastic, 6mm (blue)
18	041029	AR	. Adaptor, straight, 10mm to 6mm, push fit
19	041030	AR	. Tee, plastic, 10mm, push fit
NI	041031	AR	. . Tube, plastic, 10mm (blue)

Notes:-
 * Uses only 6mm water tubing and fittings.
 ** Uses both 6mm and 10mm water tubing and fittings

<i>Item</i>	<i>Part Number</i>	<i>Quantity</i>	<i>Description</i>
Suction Nozzle Lifting Arrangement			
1	027119	1	Ram, hydraulic, suction nozzle lift Page 200
NI	011629	1	Seal kit, ram
2	011152	1	Seal, Dowty, $\frac{1}{4}$ " BSP
3	027804	1	Adaptor, restrictor, M/M, $\frac{1}{4}$ " BSP x $\frac{3}{64}$ " orifice, (orange)
4	014224	1	Bracket, pulley, RH
NI	013904	1	Bracket, pulley, LH
NI	023844	1	Bracket, pulley, LH (dual sweep vehicles only)
5	011096	1	Washer, M12
6	011077	1	Nut, M12, Nyloc
7	011011	4	Setscrew, hex head, M8 x 25mm
8	011073	4	Nut, M8, Nyloc
9	010709	1	Pulley (complete with bush) $\varnothing 3$ " (76.2mm)
10	011035	2	Setscrew, M10 x 50mm
11	011075	2	Nut, M10, Nyloc
12	010248	1	Tensioner (complete with nuts and washers)
13	031379	1	Cable, one-piece, steel with fabric core, $\varnothing 6$ mm, includes tensioner

<i>Item</i>	<i>Part Number</i>	<i>Quantity</i>	<i>Description</i>
Standard Wander Hose Assembly			
1	012488	1	Spigot (mounts to antiluce fasteners on rear door or side access hatch)
2	013537	1	Gasket
3	010119	3.0m	Hose, flexible
4	010519	2	Clamp, worm drive, 135-165mm
5	010587	1	Pipe, nozzle
6	010321	1	Handle, wander hose
	010509	2	. Clip, toggle
	021841	2	. Hook, toggle clip
7	010245	4	Hooks



Right Hand shown, other versions similar

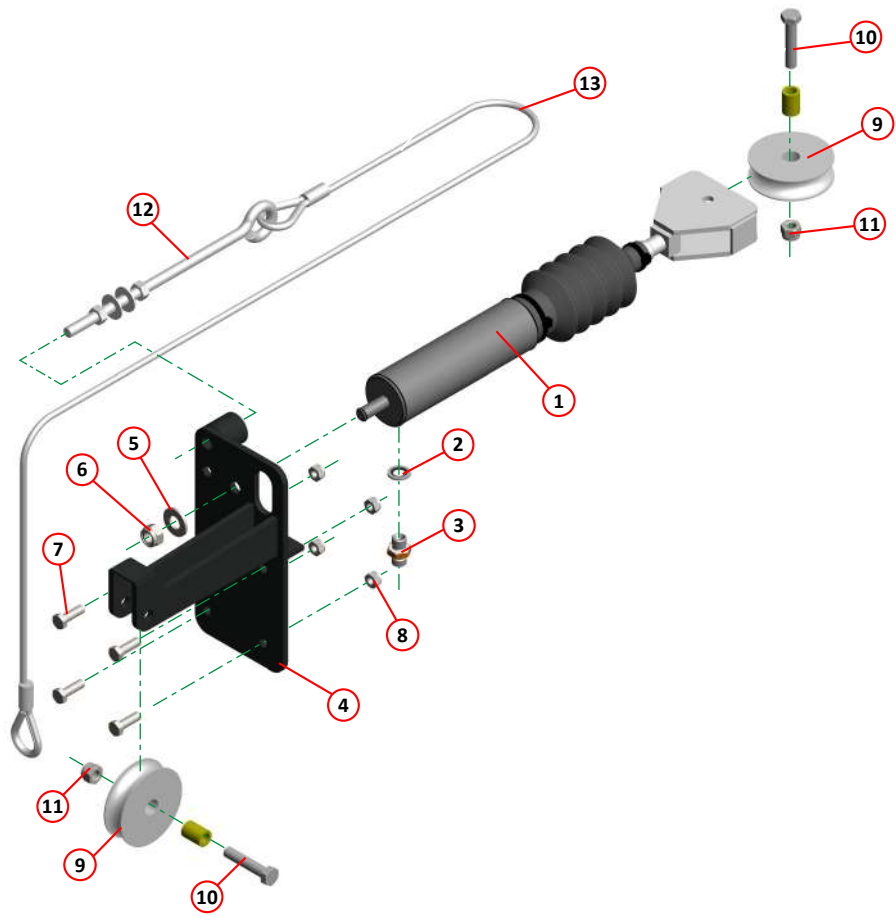

SUCTION NOZZLE LIFTING ARRANGEMENT

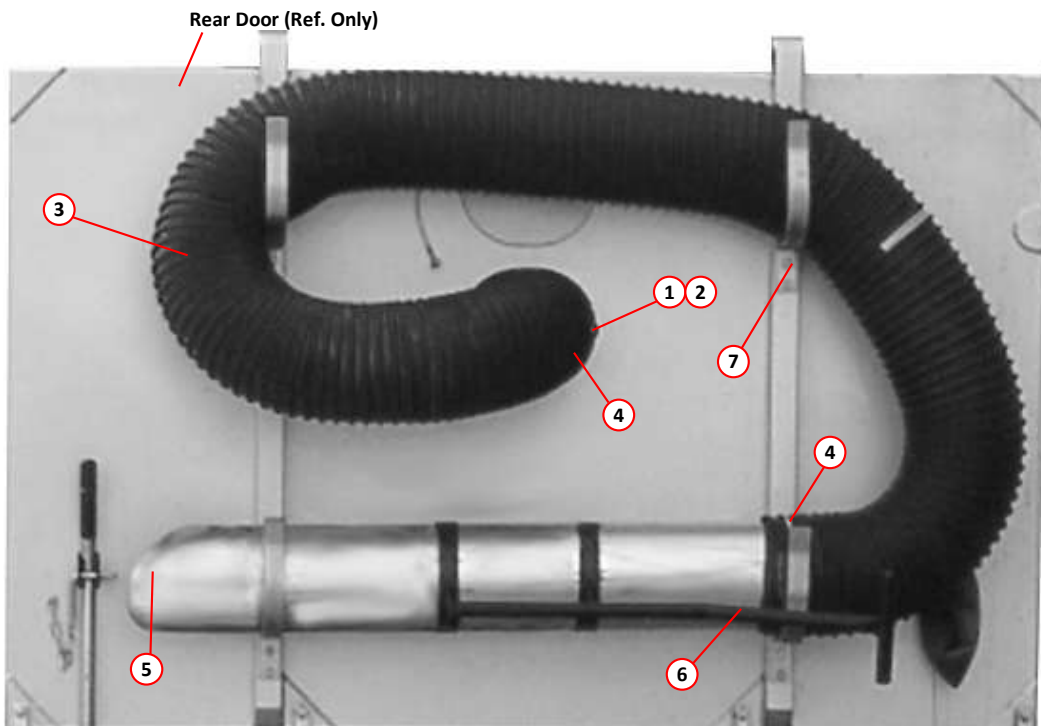

STANDARD WANDER HOSE ASSEMBLY

<i>Item</i>	<i>Part Number</i>	<i>Quantity</i>	<i>Description</i>
Overhead Boom Arrangement			
1	027126	1	Support elbow
2	011808	1	. Clip
3	010746	1	Cover, elbow
4	011079	2	. Wing nut
5	035693	2	Fixing tab
6	035696	1	Housing
6	035697	1	Housing (Hi-Tip)
7	028448	1	Aluminium suction tube 1560mm long
8	023493	1	. Strap, suction tube
9	010950	1	Hose $\frac{3}{8}$ " black
10	010516	2	. Clamp, worm drive, 11-16mm
11	010922	1	. Hose tail, $\frac{1}{4}$ " BSP x $\frac{3}{8}$ " hose
12	010928	1	. Back nut, $\frac{1}{4}$ " BSP
13	011169	1	. Elbow, swivel, $\frac{1}{4}$ " BSP
14	010112	1	. Nozzle
15	012926	1	. Spray jet, LF6-80
16	027125	1	Suction elbow
17	012253	2	. Antiluce, (small)
18	021944	2	. Double wound Grip 'R' Clip
19	020711	1	. Leash cable
20	013577	1	. Swivel spring hook
21	012486	1	. Cap plate
22	023599	1	. Ring pull
23	010526	1	. Chain

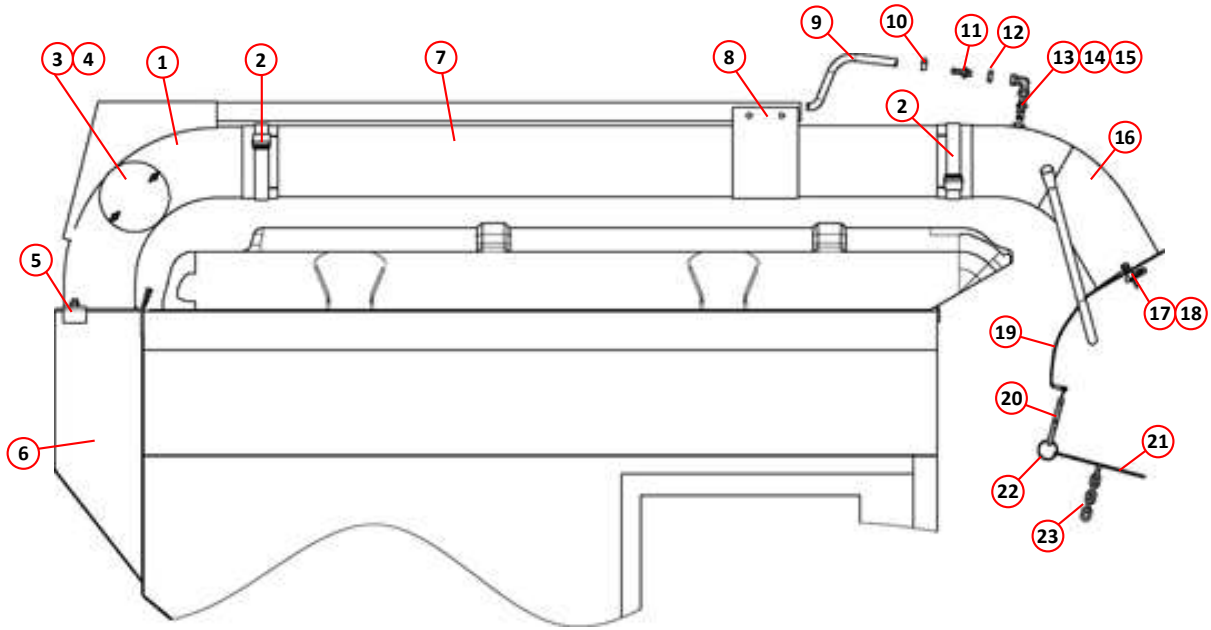

OVERHEAD BOOM ARRANGEMENT

Hopper and Related Equipment

<i>Assembly/Description</i>	<i>Page</i>
Hopper - General Arrangement.....	130
Hopper Rear - General Arrangement	132
Rear Door - General Arrangement	134
Internal Hopper Components	136
Suction Fan Assembly.....	136
Auto Blanking Main Assembly	138
Standard Wander Hose Assembly	140
Wander Hose Manual Blanking Assembly	140
Overhead Boom Arrangement	142
Hi-Tip Hopper and Associated Components.....	144
Hydraulically Operated Rear Door Arrangement.....	146

Item	Part Number	Quantity	Description
Hopper - General Arrangement			
1	025415	1	Hopper complete assembly
2	025960	1	Hopper extension LH
NI	025626	1	Hopper extension RH
3	034590	1	. Extension panel LH Page 84
4	026417	4	. . Bolt (DZUS fastener)
	023229	4	. . Washer (DZUS fastener)
	023231	4	. . Receiver (DZUS fastener)
NI	036853	1	. Extension panel RH Page 84
	026417	4	. . Bolt (DZUS fastener)
	023229	4	. . Washer (DZUS fastener)
	023231	4	. . Receiver (DZUS fastener)
5	025077	1	. Fan plate
6	011075	8	. Nut, M10, Nyloc
7	011424	8	. Washer large M10
8	025240	1	. Impellor
9	025564	1	. Suction Fan motor assembly Page 136, 188
10	024790	1	. Inlet cone
NI	039674	1	. . Fan guard
11	021526	1	. Side loading door LH
NI	021525	1	. Side loading door RH
	000261	2	. . Bolt, M8 x 55mm, stainless steel
	000263	1	. . Nut, M8, Nyloc, stainless steel
12	013599	1	. . Seal, side loading door
13	021523	1	. . Handle, side loading door
	000257	2	. . . Setscrew, M8 x 25mm, stainless steel
	000264	2	. . . Washer, M8, stainless steel
	000263	1	. . . Nut, M8, Nyloc, stainless steel
14	031601	1	. . Catch bracket
	000252	2	. . . Setscrew, M6 x 20mm, stainless steel
	000254	2	. . . Washer, M6, stainless steel
	000253	2	. . . Nut, M6, Nyloc, stainless steel
15	013702	1	. . Antiluce large
16	012486	1	. . Cap plate
	025222	0.5m	. . Titanfast DX78
17	020711	1	. . Leash cable
	000258	1	. . . Setscrew, M8 x 30mm, stainless steel
	000262	2	. . . Nut, M8, stainless steel
	000263	2	. . . Nut, M8, Nyloc, stainless steel
18	012253	4	. Antiluce
19	025436*	1	. Capping LH
NI	040662*	1	. Capping LH (slotted)
NI	025437*	1	. Capping RH
NI	040663*	1	. Capping RH (slotted)
20	013594	AR	. Seal, front aperture
21	011877	1	. Hopper safety prop
22	011757	1	. Hopper safety prop pocket Page 42
23	011577	1	. Hopper lift Ram (standard) Page 204
NI	012203	1	. . Seal kit for hopper ram 011577
24	011640	1	. Hinge pin (hopper lift)
	011013	2	. Setscrew, M8 x 35mm
	011073	2	. Nut, M8, Nyloc
25	033210	1	. Hopper sensor stop
	011043	1	. . Bolt, M10 x 70mm
	011074	2	. . Washer, M10
	011075	1	. . Nut, M10, Nyloc

} Per side loading door

Notes:-
* Please contact Scarab Parts Department regarding these parts.

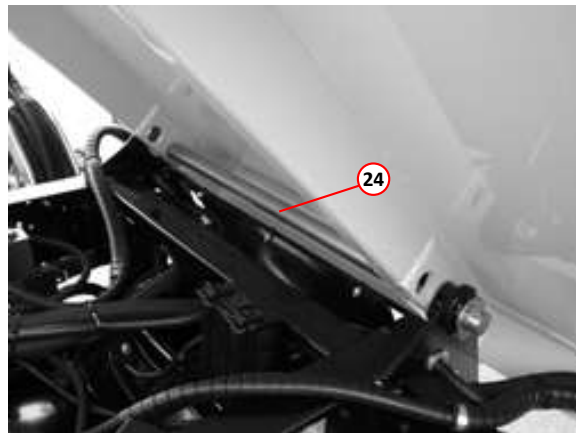
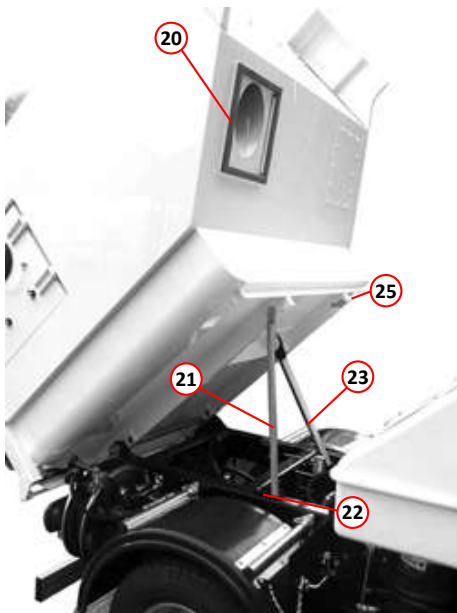
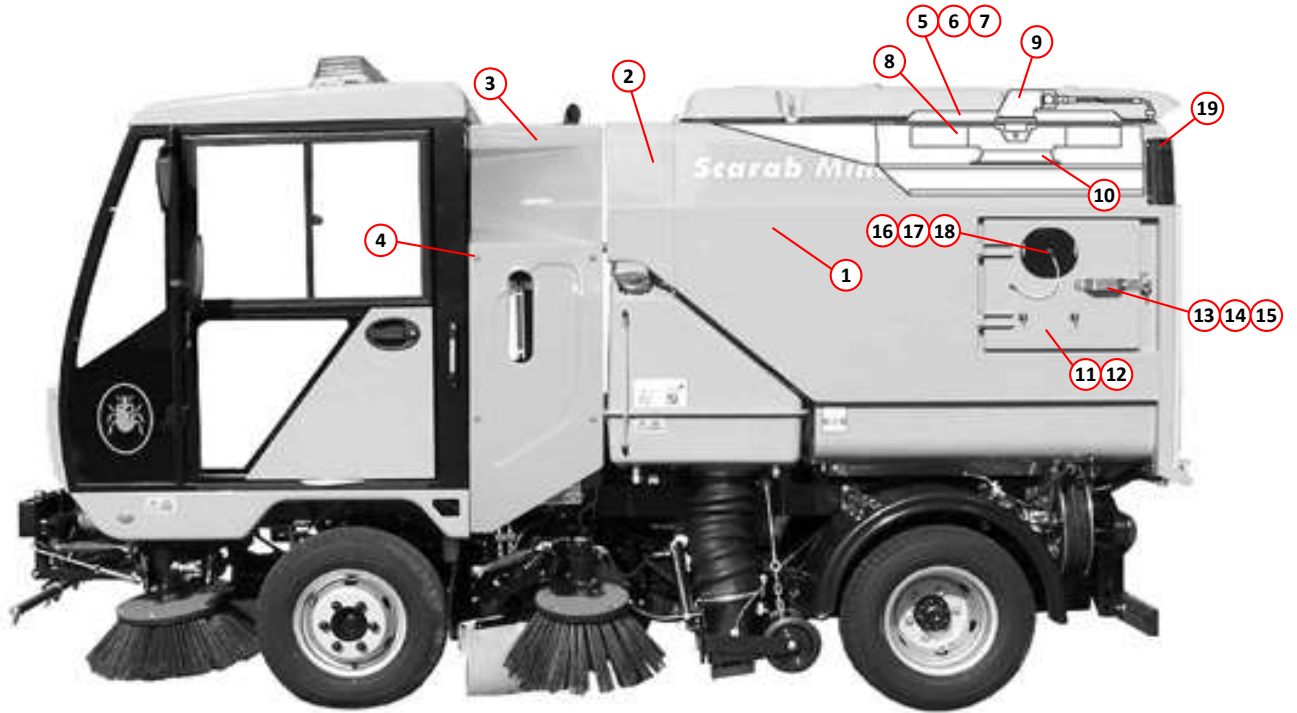

HOPPER GENERAL ARRANGEMENT

<i>Item</i>	<i>Part Number</i>	<i>Quantity</i>	<i>Description</i>
Hopper Rear - General Arrangement			
1	028023	1	Cover, hopper GRP
NI	013952	4.5m	. Seal (goes between hopper cover and hopper top)
NI	025680	5	. Retaining clip
NI	010509	5	. Fastener with hinge
	000286	10	. . Screw, slotted countersunk, M6 x 20mm
	011090	10	. . Washer, M6
	011071	10	. . Nut, M6, Nyloc
2	010304	1	Beacon
3	010297	1	. Bracket, beacon
	011011	2	. Setscrew, M8 x 25mm
	011073	2	. Nut, M8, Nyloc
	030952	1	. Lens cover (spares)
	011496	1	. Bulb (spare) 12 Volt x 21 Watt
4	027923	2	. Cover plate
5	000248	4	. . Plastic hand screw
NI	027924	1	. . Fan protection cover
NI	010502	1	. . Pull handle for cover
NI	000248	2	. . Plastic hand-screw
6	014995	1	Handle rear, door locking
7	014997	1	. Plastic handle grip
8	024147	1	Rear bumper
9	031244	1	Rubber flap (fuel filler dual sweep machines)
10	039336	1	High level brake lightbar Page 224
	000444	2	. Screw, socket cap head, M5 x 12mm
11	038193	4	. . Insulated spacer
	000155	2	. . . Nut, M5, Nyloc
12	040354	1	Rear camera
	000444	2	. Screw, socket cap head, M5 x 12mm
	000155	2	. . Nut, M5, Nyloc
NI	040666	1	. . Camera bracket (only when rear wander hose fitted)
	011010	4	. . . Setscrew, M8 x 20mm
	011092	8 Washer
	011073	4 Nut, M8, Nyloc

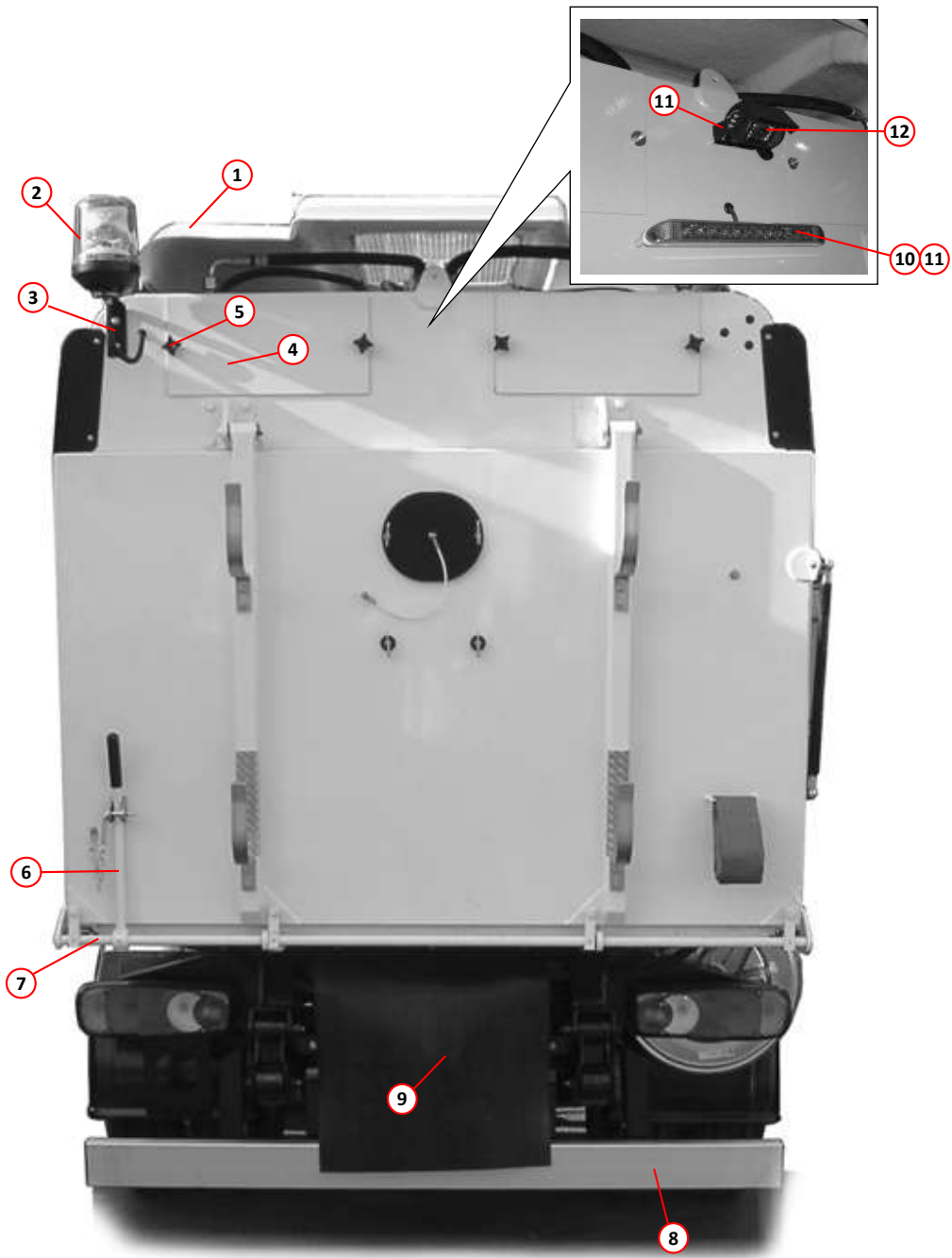

HOPPER REAR ARRANGEMENT

<i>Item</i>	<i>Part Number</i>	<i>Quantity</i>	<i>Description</i>
Rear Door - General Arrangement			
1	014736	1	Rear door
2	039893	1	Seal, rear door
NI	014737	1	Rear door (Hi-Tip)
NI	039897	1	. Seal, rear door (Hi-Tip)
3	025262	2	. Hinge
4	010245	4	. Hook for wander hose
	000259	8	. . Bolt, M8 x 60mm, stainless steel
	000258	8	. . Nut, M8, Nyloc, stainless steel
5	032181	2	. Door rib protector
6	014997	1	. Plastic handle grip
7	010232	1	. Pin, chain and bracket
8	010955	1	Hose, drain
	012927	1	. Jubilee clip
9	020521	1	Gas spring
	036477	1	Gas spring (1.3 and 1.6 hi-tip)
10	012253	4	. Antiluce clips
	021979	2	. . Rubber washer
11	020711	1	. Leash cable
	000258	1	. . Setscrew, M8 x 30mm, stainless steel
	000263	1	. . Nut, M8, stainless steel
	000263	1	. . Nut, M8, Nyloc, stainless steel
12	012486	1	Blanking plate, rear door
	000263	1	. Nut, M8, stainless steel
	000263	1	. Nut, M8, Nyloc, stainless steel
13	020523	1	Prop, rear door
14	034682	1	Handle, bracket, Hi-Tip remote
15	034683	1	. Handle, Hi-Tip remote
16	022816	1	. Locking bar, Hi-Tip remote

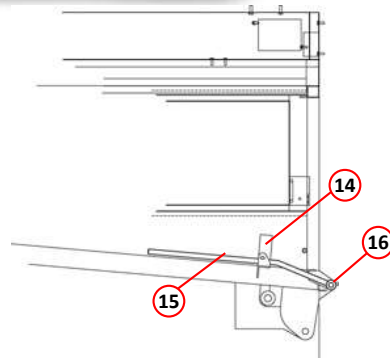
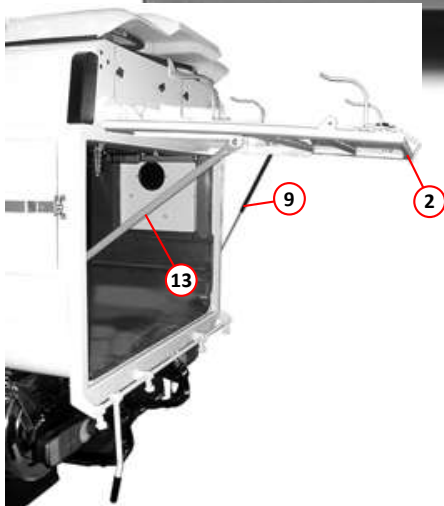
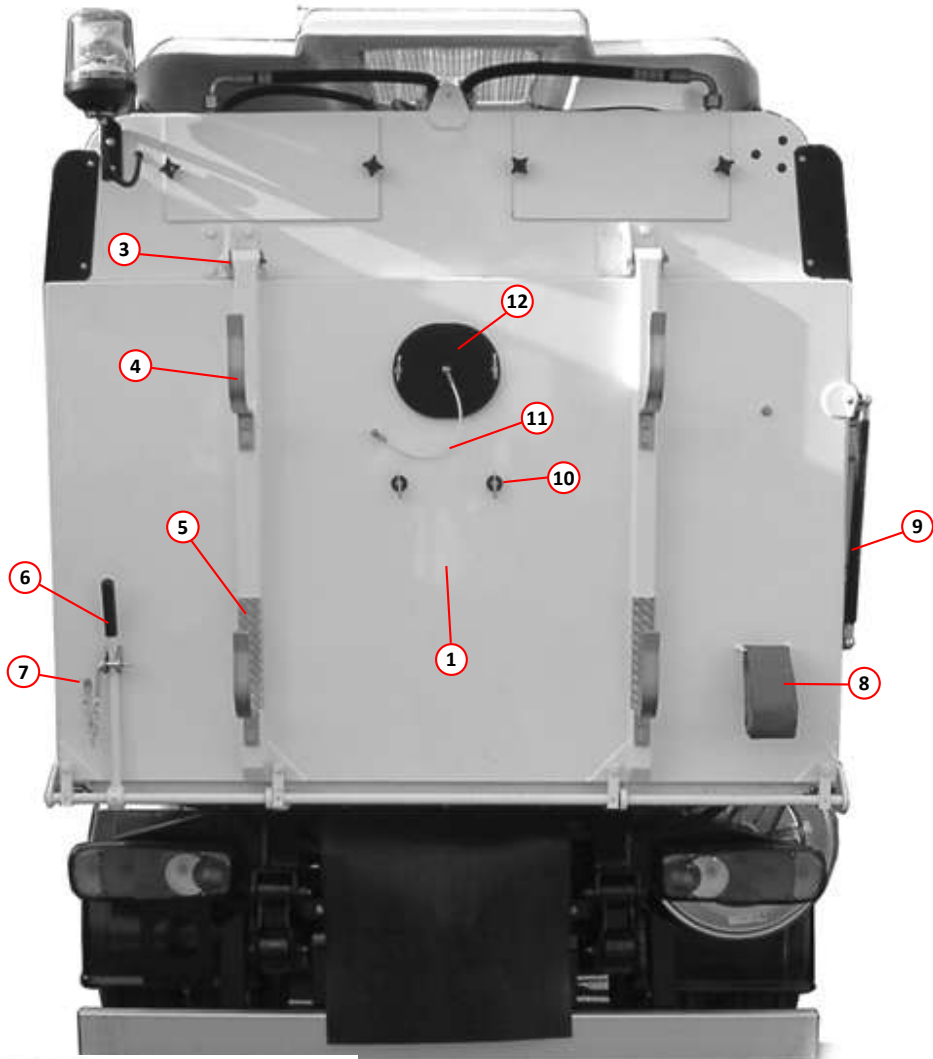

Hi-Tip Remote, rear door locking

REAR DOOR ARRANGEMENT

Item	Part Number	Quantity	Description
Internal Hopper Components			
1	025261	1	Screen
1	025668	1	Screen, fine mesh type (dual sweep machines)
2	025245	3	. Gudgeon pin
3	013506	3	. Pin
4	013507	3	. Linch pin
NI	027744	1	. Handle, screen rear
5	025529	AR	Inlet tube
5	034235	AR	Inlet tube, PU COATED
	000329	13	. Screw, socket button head, M8 x 20mm, stainless steel, per tube
	000263	13	. Nut, M8 Nyloc, stainless steel, per tube
NI	028822	1	Deflector, LH (single sweep)
NI	035586	1	Deflector, LH (single sweep), PU COATED
6	028823	1	Deflector, RH (single sweep)
6	035587	1	Deflector, RH (single sweep), PU COATED
NI	025533	1	Deflector, LH (dual sweep)
NI	034240	1	Deflector, LH (dual sweep), PU COATED
6	025534	1	Deflector, RH (dual sweep)
6	034241	1	Deflector, RH (dual sweep), PU COATED
7	014587	1	Blanking plate
	000329	12	. Screw, socket button head, M8 x 20mm, stainless steel, per tube
	000263	12	. Nut, M8, Nyloc, stainless steel, per tube

Item	Part Number	Quantity	Description
Suction Fan Assembly			
1	025077	1	Fan plate
2	025240	1	. Impellor
3	024790	1	Inlet cone
4	039674	1	. . Fan guard
5	025564	1	. Fan motor assembly Page 130, 188
6	024641	1	. Motor, fan
NI	027237	1	. . Seal Kit, for 024641 VOAC fan motor
NI	024791	1	. . . Washer, VOAC motor
NI	011052	1	. . . Setscrew, hex head, M12 x 30mm
NI	025390	1	. Valve block, VOAC motor
NI	002101	1	. . O-Ring, (base of VOAC motor)
NI	011156	1	. . Seal, Dowty (for plug)
NI	000048	8	. . Screw, socket cap head, M10 x 80mm
NI	011095	8	. Washer, spring, M10
NI	011155	2	. Seal, Dowty, $\frac{3}{4}$ " BSP
NI	011247	1	. Seal, Dowty, M18
NI	011248	1	. Adaptor, M18 x $\frac{3}{8}$ " BSP
NI	011172	1	. Elbow, swivel, $\frac{3}{8}$ " BSP
NI	010921	1	. Hose Stem $\frac{3}{8}$ " x $\frac{3}{8}$ " BSP
NI	010928	1	. Nut, brass $\frac{3}{8}$ " BSP
NI	011161	2	. Adaptor, $\frac{3}{4}$ " BSP
NI	002076	1	. Plug M12 x 1
NI	025184	1	Speed sensor lead
NI	004226	1	. Plug
NI	004227	1	. Seal
NI	004228	1	. Seal
NI	014157	1	Hose $\frac{5}{8}$ " x 4350mm - fan return
NI	001070	1	Hose $\frac{5}{8}$ " x 2230mm - fan feed
NI	013514	1	Fan scraper Page 90

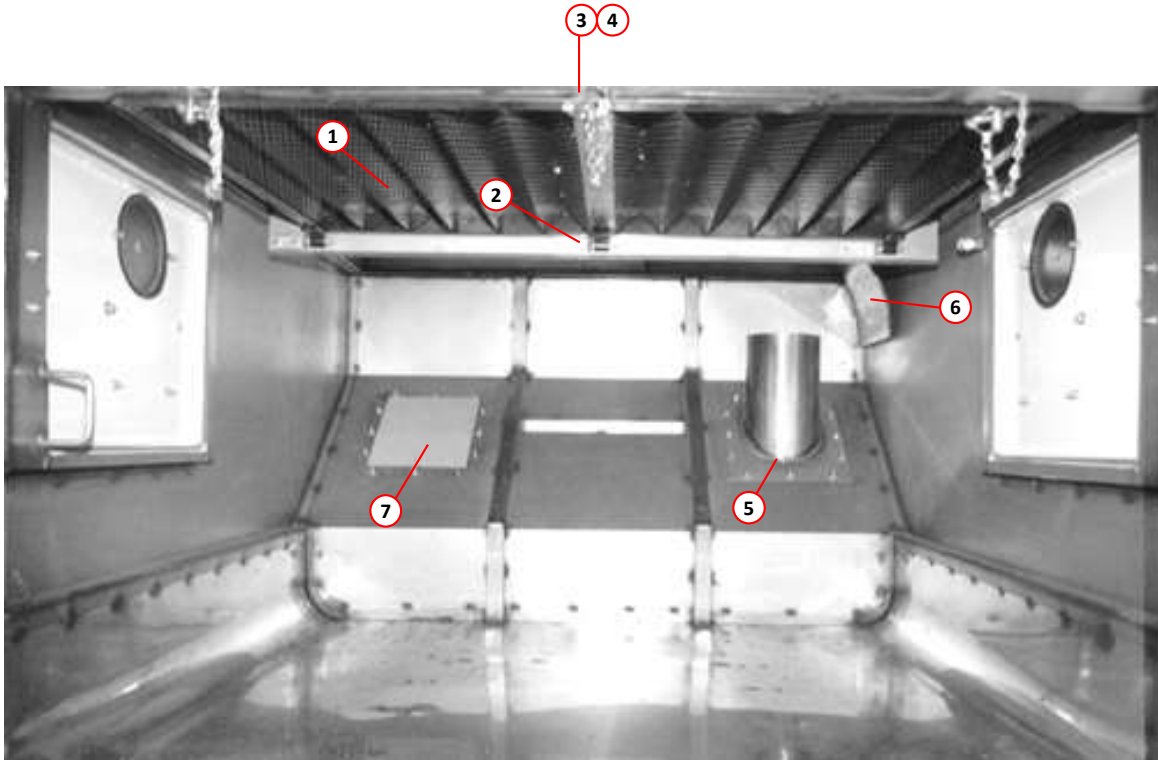

INTERNAL HOPPER COMPONENTS

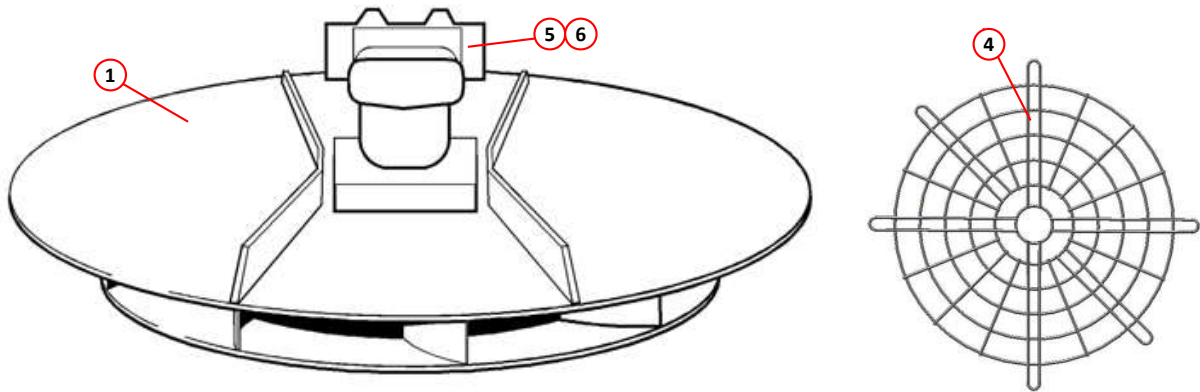
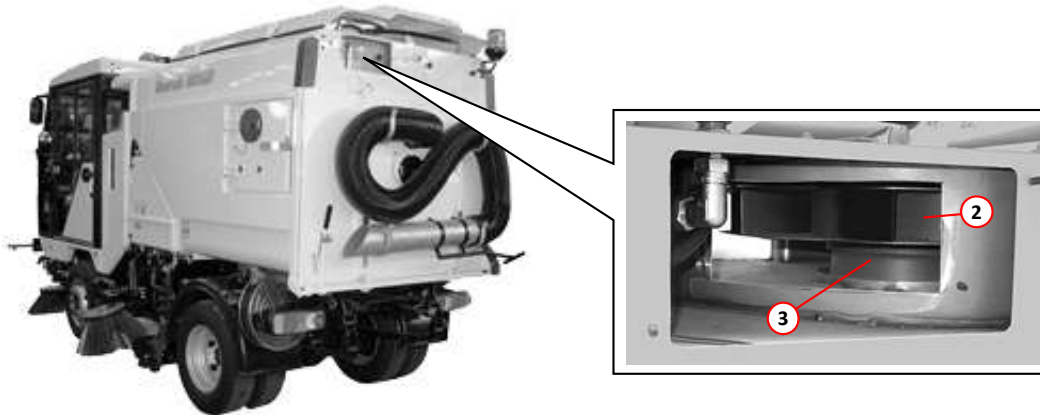

SUCTION FAN ASSEMBLY

Item	Part Number	Quantity	Description
Auto Blanking Main Assembly			
1	025531	1	Mounting plate, LH
NI	025532	1	Mounting plate, RH
	000257	5	. Setscrew, M8 x 25mm, stainless steel
	000263	5	. Nut, M8, stainless steel
	000264	5	. Washer, M8, stainless steel
	000273	1	. Setscrew, M12 x 25mm, stainless steel
	000277	1	. Washer, M12, stainless steel
	000275	1	. Nut, M12, Nyloc, stainless steel
NI	013488	4	. Bush
2	025530	2	. Flap
2	034237	2	. Flap, PU COATED
3	025526	1	. . Flap arm, LH
4	025527	1	. . Flap arm, RH
5	028822	1	. Deflector, LH
6	028823	1	. Deflector, RH
	011051	4	. . Setscrew, M12 x 25mm
	011096	16	. . Washer, M12
	011076	4	. . Nut, M12, Nyloc
7	022350	2	. Ram, hydraulic Page 204
	011122	2	. . Split pin
	011135	2	. . Washer, M16
8	014469	2	. Clevis M12
9	025528	2	. Lever
	000211	2	. . Nut M12 x 1. 25
	011031	2	. . Setscrew, M10 x 25mm
10	010991	2	. Hose, rubber, $\frac{1}{4}$ " BSP x 550mm
11	010981	2	. Hose, rubber, $\frac{1}{4}$ " BSP x 711mm
12		2	. Inlet tube Page 136
13		1	Valve control, hydraulic, (dual sweep shown) Page 210
	011010	2	. Setscrew, hex head, M8 x 20mm
	011073	2	. Nut, M8 Nyloc
14	001147	1	. Hose, rubber, $\frac{1}{4}$ " BSP x 500mm, 90° ends
15	001107	2	. Hose, rubber, $\frac{1}{4}$ " BSP x 1300mm, straight + 90° ends
15	010987	2	. Hose, rubber, $\frac{1}{4}$ " BSP x 1660mm, straight + 90°ends (1.3 Hi-Tip)
16	001101	2	. Hose, rubber, $\frac{1}{4}$ " BSP x 1125mm, straight + 90° ends
16	001106	2	. Hose, rubber, $\frac{1}{4}$ " BSP x 1820mm, straight + 90° ends (1.3 Hi-Tip)
17	001106	1	. Hose, rubber, $\frac{1}{4}$ " BSP x 1820mm, straight + 90° ends
18	001148	1	. Hose, rubber, $\frac{1}{4}$ " BSP x 400mm, 90° ends
19	010958	AR	. Pipe, rubber, $\frac{3}{8}$ " bore
20	010516	1	. Clamp, worm drive, 11-16mm

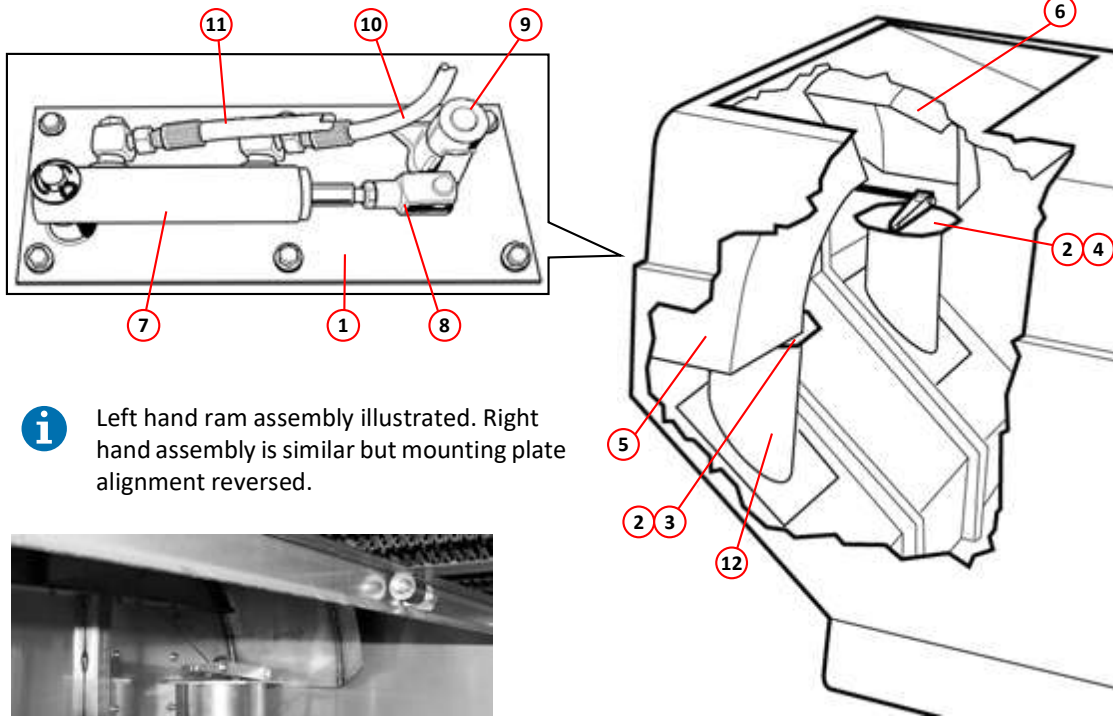

i Left hand ram assembly illustrated. Right hand assembly is similar but mounting plate alignment reversed.

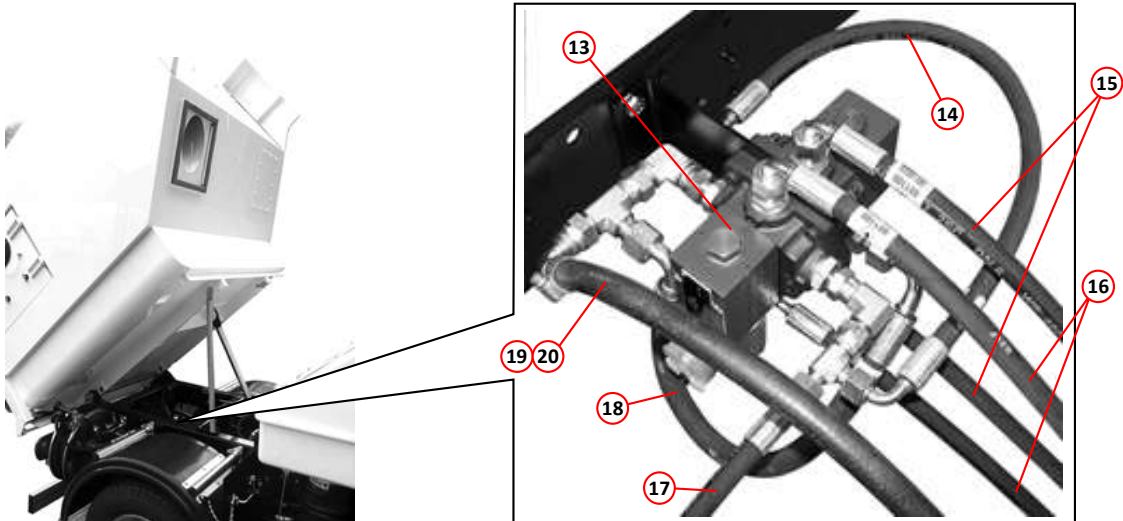

AUTO BLANKING ASSEMBLY

<i>Item</i>	<i>Part Number</i>	<i>Quantity</i>	<i>Description</i>
Standard Wander Hose Assembly			
1	012488	1	Spigot (mounts to antiluce fasteners on rear door or side access hatch)
2	013537	1	Gasket
3	010119	3.0m	Hose, flexible
4	010519	2	Clamp, worm drive, 135-165mm
5	010587	1	Pipe, nozzle
6	010321	1	Handle, wander hose
	010509	2	. Clip, toggle
	021841	2	. Hook, toggle clip
7	010245	4	Hooks
	011017	8	. Bolt, M8 x 60mm
NI	032181	4	. . Door rib protect

<i>Item</i>	<i>Part Number</i>	<i>Quantity</i>	<i>Description</i>
Wander Hose Manual Blanking Assembly			
1	026819	1	Spigot, wander hose
2	026818	1	Blanking flap
3	026817	2	Gasket spacer strip
4	013507	1	Pin and chain

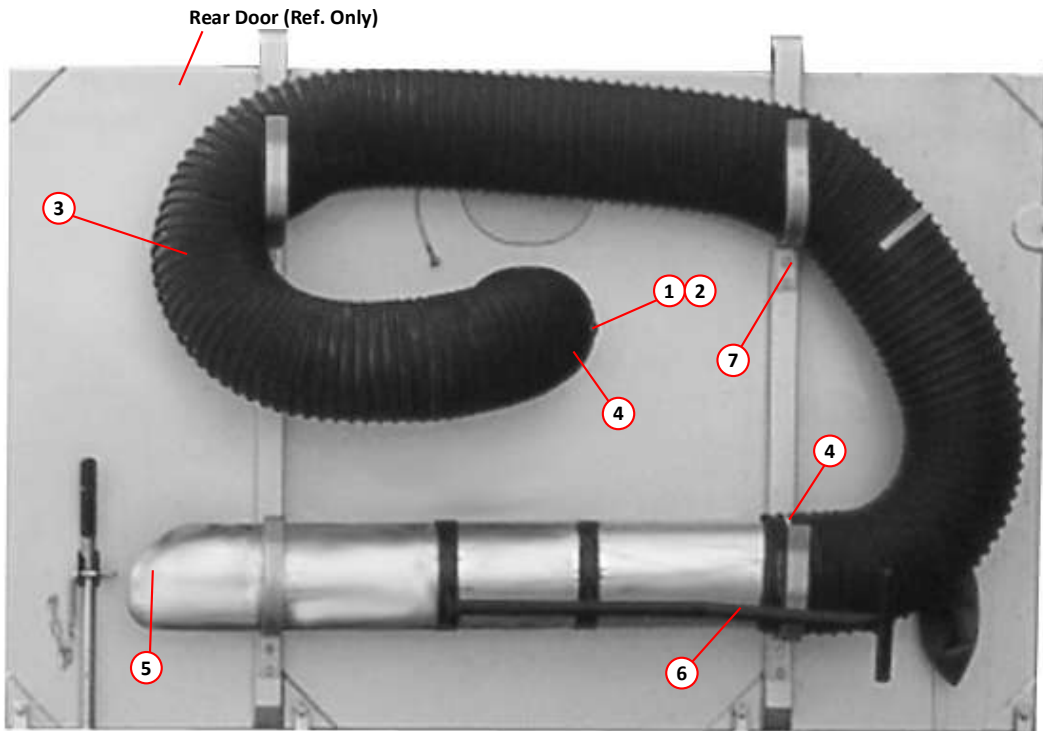

STANDARD WANDER HOSE ASSEMBLY

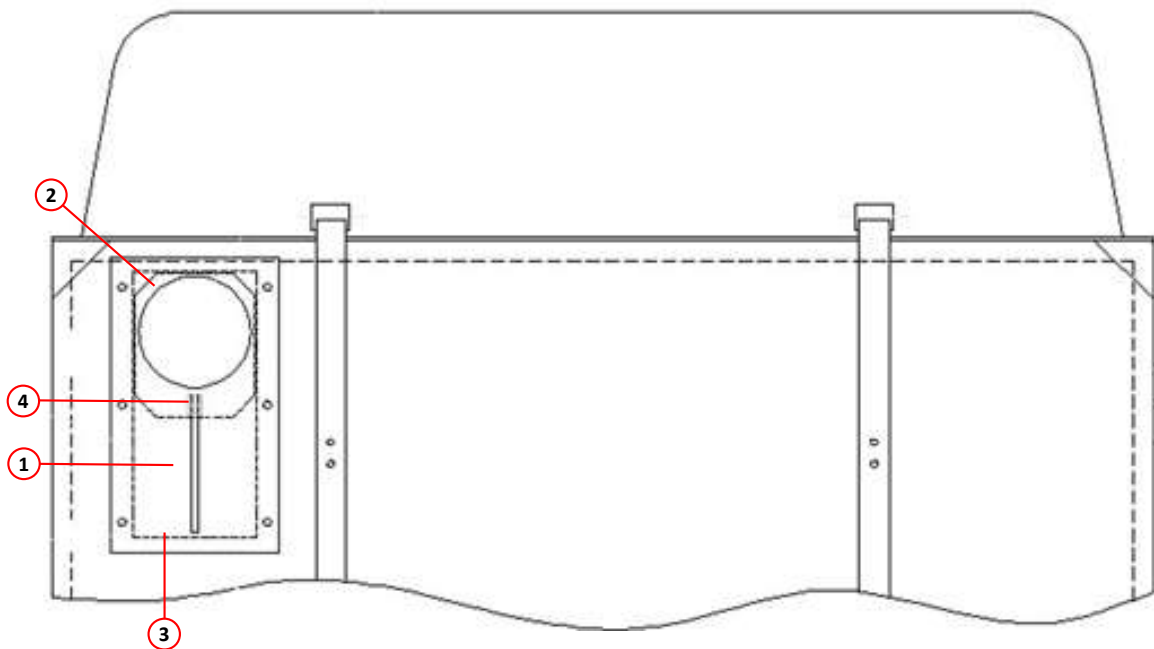

WANDER HOSE MANUAL BLANKING ASSEMBLY

<i>Item</i>	<i>Part Number</i>	<i>Quantity</i>	<i>Description</i>
Overhead Boom Arrangement			
1	027126	1	Support elbow
2	011808	1	. Clip
3	010746	1	Cover, elbow
4	011079	2	. Wing nut
5	035693	2	Fixing tab
6	035696	1	Housing
6	035697	1	Housing (Hi-Tip)
7	028448	1	Aluminium suction tube 1560mm long
8	023493	1	. Strap, suction tube
9	010950	1	Hose $\frac{3}{8}$ " black
10	010516	2	. Clamp, worm drive, 11-16mm
11	010922	1	. Hose tail, $\frac{1}{4}$ " BSP x $\frac{3}{8}$ " hose
12	010928	1	. Back nut, $\frac{1}{4}$ " BSP
13	011169	1	. Elbow, swivel, $\frac{1}{4}$ " BSP
14	010112	1	. Nozzle
15	012926	1	. Spray jet, LF6-80
16	027125	1	Suction elbow
17	012253	2	. Antiluce, (small)
18	021944	2	. Double wound Grip 'R' Clip
19	020711	1	. Leash cable
20	013577	1	. Swivel spring hook
21	012486	1	. Cap plate
22	023599	1	. Ring pull
23	010526	1	. Chain

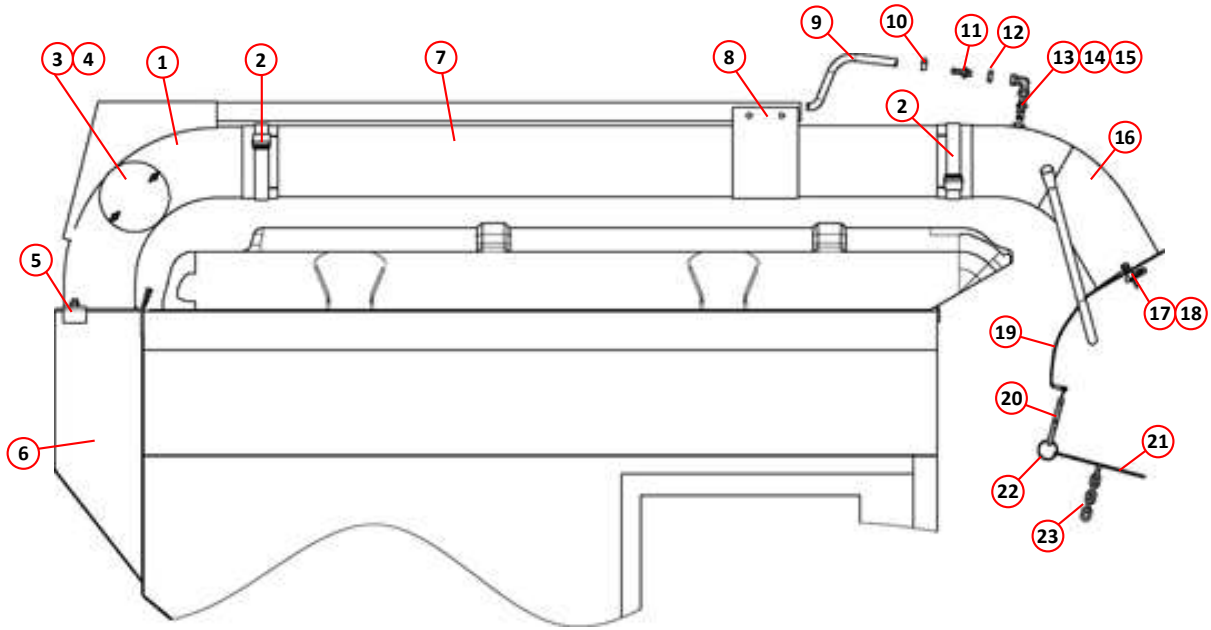

OVERHEAD BOOM ARRANGEMENT

<i>Item</i>	<i>Part Number</i>	<i>Quantity</i>	<i>Description</i>
Hi-Tip Hopper and Associated Components			
1	025643	1	Hopper (Hi-Tip 1.3)
1	026270	1	Hopper (Hi-Tip 1.6)
2	026720	2	. Hopper lift ram, (Hi-Tip 1.3) Page 204
2	026719	2	. Hopper lift ram, (Hi-Tip 1.6) Page 204
3	011952	1	. Top link (Hi-Tip 1.3)
3	020112	1	. Top link (Hi-Tip 1.6)
4	023495	2	. Link (Hi-Tip 1.3)
4	020231	1	. Link (Hi-Tip 1.6)
5	014709	1	. Sub frame (Hi -Tip 1.3)
5	020056	1	. Sub frame (Hi -Tip 1.6)
	011031	10	. . Setscrew, M10 x 25mm
	011075	10	. . Nut, M10, Nyloc
6	014722	2	. Trunnion plate LH
7	014721	2	. Trunnion plate RH
	011031	7	. . Setscrew, M10 x 25mm
	011032	4	. . Setscrew, M10 x 20mm
8	014723	1	. Rear support Bracket
	011032	4	. . Setscrew, M8 x 30mm
	011075	4	. . Nut, M10, Nyloc
9	020113	2	. Outrigger
10	011974	2	. . Outrigger leg
	000184	2	. . . Bolt, M16 x 120mm
	011060	2	. . . Nut, M16, Nyloc
	011031	2	. . . Setscrew, M8 x 35mm
	011075	2	. . . Nut, M8, Nyloc
11	013138	2	. Link pin
12	*	2	. Linch pin and chain
13	*	2	. Fixing chain
14	042160	1	. Bracket, rear light, right hand (Hi-Tip 1.6) Page 48
NI	042159	1	. Bracket, rear light, left hand (Hi-Tip 1.6) Page 48
15	034562	1	. Rear chute assembly

Notes:-

* Please contact Scarab Parts Department regarding these items.

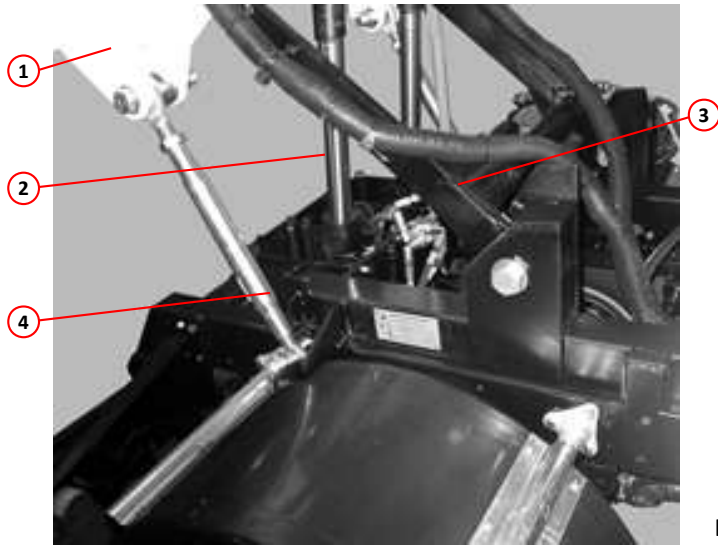

HI-TIP ASSEMBLY

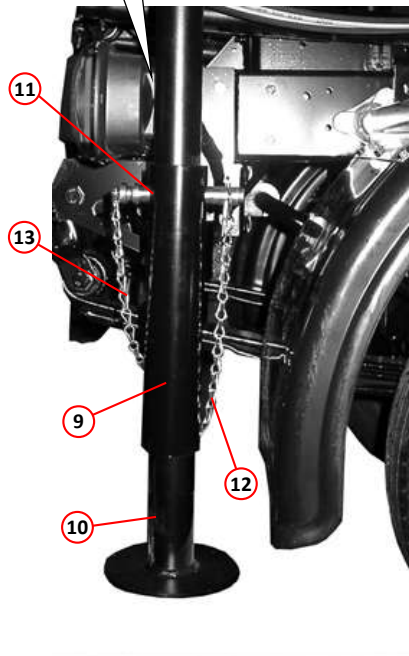
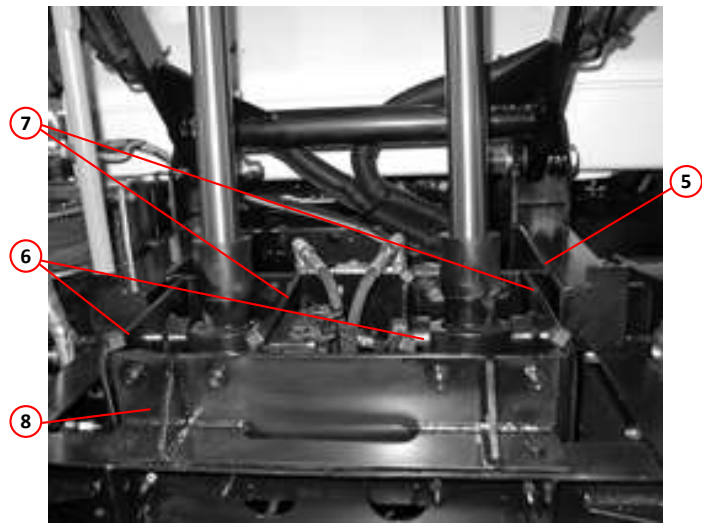
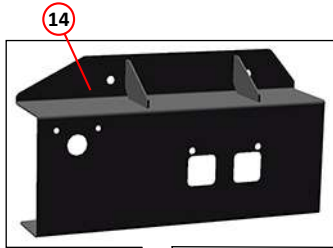

OUTRIGGER

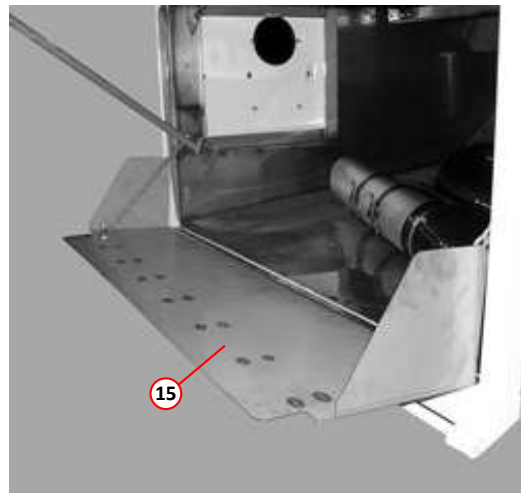

REAR CHUTE

Item	Part Number	Quantity	Description
Hydraulically Operated Rear Door Arrangement			
1	022511	1	Ram, hydraulic, rear door open/close Page 204
2	030539	1	. Support, ram
NI	033273	1	. Support, ram (low height variants only)
NI	040673	1	. Support , ram with camera mount (from May 2013 on)
NI	040354	1	. . Rear camera Page 132,223
	000257	6	. . Setscrew, M8 x 25mm, stainless steel
	000262	6	. . Nut, M8, Nyloc, stainless steel
3	014038	1	. Pin, swivel, $\varnothing 20\text{mm}$ x 70mm
	011122	2	. . Pin, split, $\frac{3}{16}$ " x $1\frac{1}{2}$ "
	011102	AR	. . Washer, M20
4	014038	1	. Pin, swivel, $\varnothing 20\text{mm}$ x 90mm
	011122	2	. . Pin, split, $\frac{3}{16}$ " x $1\frac{1}{2}$ "
	011102	AR	. . Washer, M20
5	030540	1	. Plate, ram
	000257	5	. . Setscrew, M8 x 25mm, stainless steel
	000262	5	. . Nut, M8, Nyloc, stainless steel
6	011317	2	. Hose, rubber, $\frac{1}{4}$ " BSP x 295mm, (straight ends)
7	011269	2	. . Adaptor, bulkhead, M/M, $\frac{1}{4}$ " BSP
8	001106	2	. Hose, rubber, $\frac{1}{4}$ " BSP x 1820mm, (straight + 90° end)
9	011187	2	. . Elbow, M/M, $\frac{1}{4}$ " BSP
10	001037	2	. Hose, rubber, $\frac{1}{4}$ " BSP x 2650mm, (straight + 90° end)
11	030544	2	. Stiffener, vertical
12	030545	1	. Stiffener, horizontal
	000257	5	. . Setscrew, M8 x 25mm, stainless steel
	000262	5	. . Nut, M8, Nyloc, stainless steel
13	012582	1	Valve, check Page 208
14	023569	1	Valve, control Page 206
15	010958	AR	. Pipe, rubber, $\frac{3}{8}$ " bore
16	010516	2	. . Clamp, worm drive, size, 11-16mm
17	025599	1	. Valve, flow and pressure Page 208
18	010987	1	. . Hose, rubber, $\frac{1}{4}$ " BSP x 1660mm long, (straight ends)
19	011000	AR	. . Pipe, rubber, $\frac{5}{8}$ " bore
20	010517	2	. . . Clamp, worm drive, 18-25mm

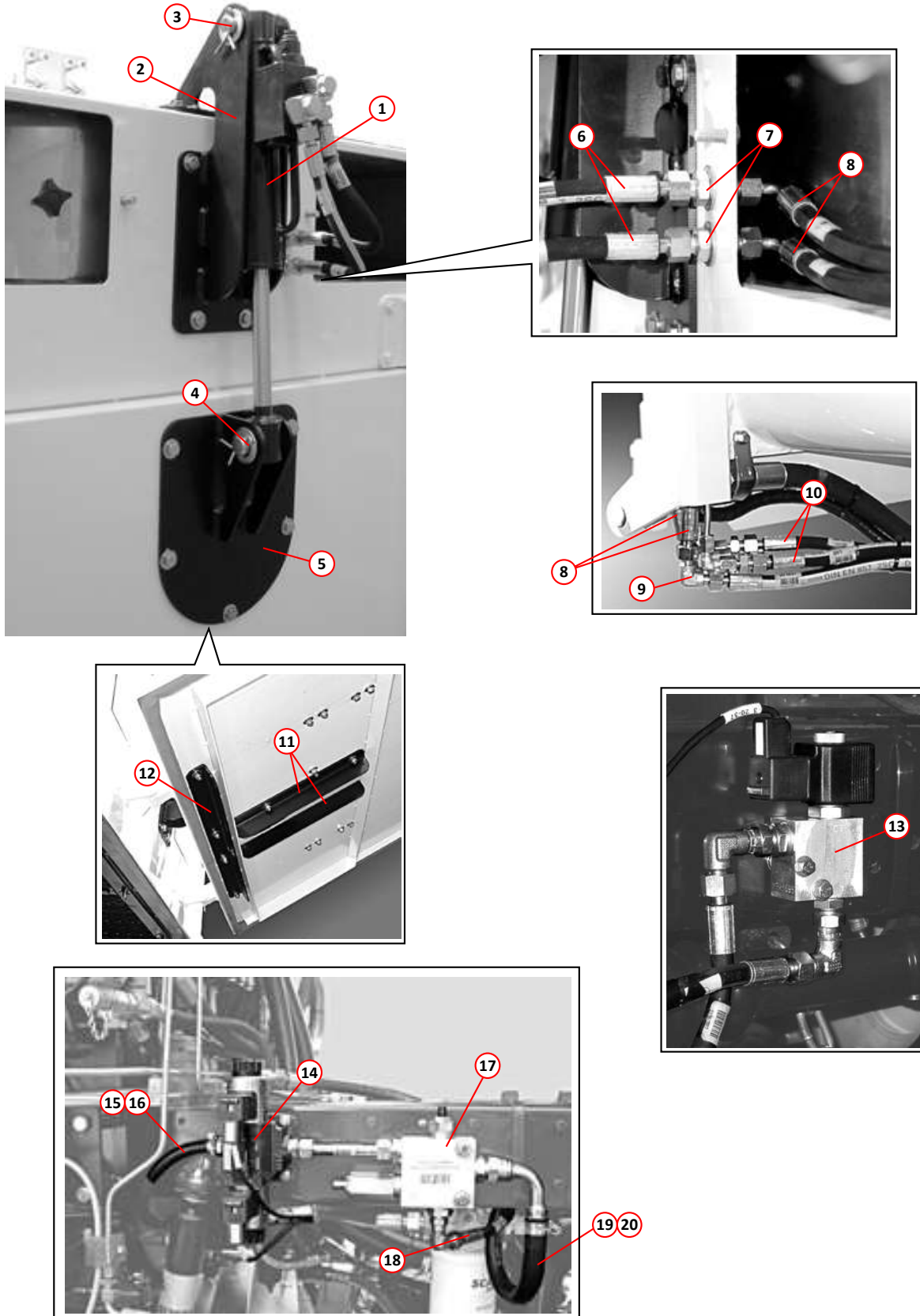

HYDRAULICALLY OPERATED REAR DOOR ARRANGEMENT

Washing and Dust Suppression

<i>Assembly/Description</i>	<i>Page</i>
Water Tank Arrangement	150
Hydrant Filler Kit and Mounting Items	152
Low Pressure Water Pump Assembly	154
Water Valve Arrangement	154
Low Pressure Water Filter Assembly	156
6 Nozzle Low Pressure Spray Bar Assembly	156
3 Nozzle Low Pressure Spray Bar Assembly	156
Low Pressure Water Spray Jet, Front and Side Brush	158
Low Pressure Water Spray Jet, Fixed Type	158
High Pressure Water Pump - Arrangement	160
High Pressure Water Pump - Components	162
High Pressure Water Hose End Stowage Arrangement	164
Detergent Feed Valve (Hand Lance)	164
Detergent Bottle and Feed Valve (Water Boom)	164
Fan Wash Assist Arrangement	166
High Pressure Spray System - Layout	168
Automatic Hose Reel - Components	168
High Pressure Water Boom Arrangement	170
High Pressure Front Spray Bar Assembly	172
High Pressure Front Spray Bar Mount	172

Item	Part Number	Quantity	Description
Water Tank Arrangement			
1	014678	1	Water tank
2	014040	1	. Hydrant filler assembly
	000254	4	. . Washer, M6, stainless steel
	000253	4	. . Nut, M,6 Nyloc, stainless steel
3	013661	1	. . Cap, filler
NI	020896	1	. Disc, rubber (located centrally on top face of tank)
	011115	4	. . Screw, Posidriv, self-tapping, No. 10 x $\frac{1}{2}$ "
4	014303	AR	. Suction tube
	000256	6	. . Setscrew, M8 x 20mm, stainless steel
	000329	2	. . Screw, socket button head, M8 x 20mm, stainless steel
	000270	8	. . Washer, M8, stainless steel
5	010951	0.5m	. . Hose, PVC clear, $\frac{3}{8}$ " bore
NI	010964	2	. . . O-Clips $\frac{9}{16}$ "
6	010912	2	. . . Elbow, galvanised, M/M, $\frac{1}{4}$ " BSP
NI	010922	2	. . . Hose tail, $\frac{1}{4}$ " BSP x $\frac{3}{8}$ "
7	023154	1	. . Suction hose
	012932	2	. . . Clamp, worm drive, 135-165mm
8	014278	1	. Bracket tank base, LH
	011092	3	. . Washer, M8
	011073	3	. . Nut, M8, Nyloc
	011055	1	. . Bolt, M12 x 65mm
	011096	2	. . Washer, M12
	011077	1	. . Nut, M12, Nyloc
9	014279	1	. Bracket tank base, RH
	011092	3	. . Washer, M8
	011073	3	. . Nut, M8, Nyloc
	011055	1	. . Bolt, M12 x 65mm
	011096	2	. . Washer, M12
	011077	1	. . Nut, M12, Nyloc
10	013462	2	. Bracket, rubber buffer mounting
	011051	4	. . Setscrew, M12 x 25mm
	011077	4	. . Nut, M12, Nyloc
11	014693	2	. Rubber buffer
	011034	4	. . Setscrew, M10 x 40mm
	011075	4	. . Nut, M10, Nyloc
	011094	4	. . Washer M10
12	030597	1	Filter assembly, water Page 156
13	011161	3	. Adaptor, M/M, $\frac{3}{4}$ " BSP
	011155	3	. Seal, dowty, $\frac{3}{4}$ " BSP
14	011168	1	. Adaptor, M/M, $\frac{1}{2}$ " BSP
15	002149	1	. Blanking cap, $\frac{1}{2}$ " BSP
16	002011	1	. Blanking cap, $\frac{3}{4}$ " BSP
17	034342	3	Water spray nozzle Page 122
	011001	3	. Setscrew, M6 x 16mm
	011091	3	. Washer, spring, M6
18	024647*	AR	. Tee, plastic, 6mm, push fit
NI	035733*	AR	. . Tube, plastic, 6mm (blue)
NI	041029*	AR	. Adaptor, straight, 10mm to 6mm, push fit
NI	041030*	AR	. Tee, plastic, 10mm, push fit
NI	041031*	AR	. . Tube, plastic, 10mm (blue)

Notes:-

* Please check if you require only 6mm or a combination of 6mm and 10mm water tube and fittings for suction nozzle dust suppression system, before ordering parts. See Page 122.

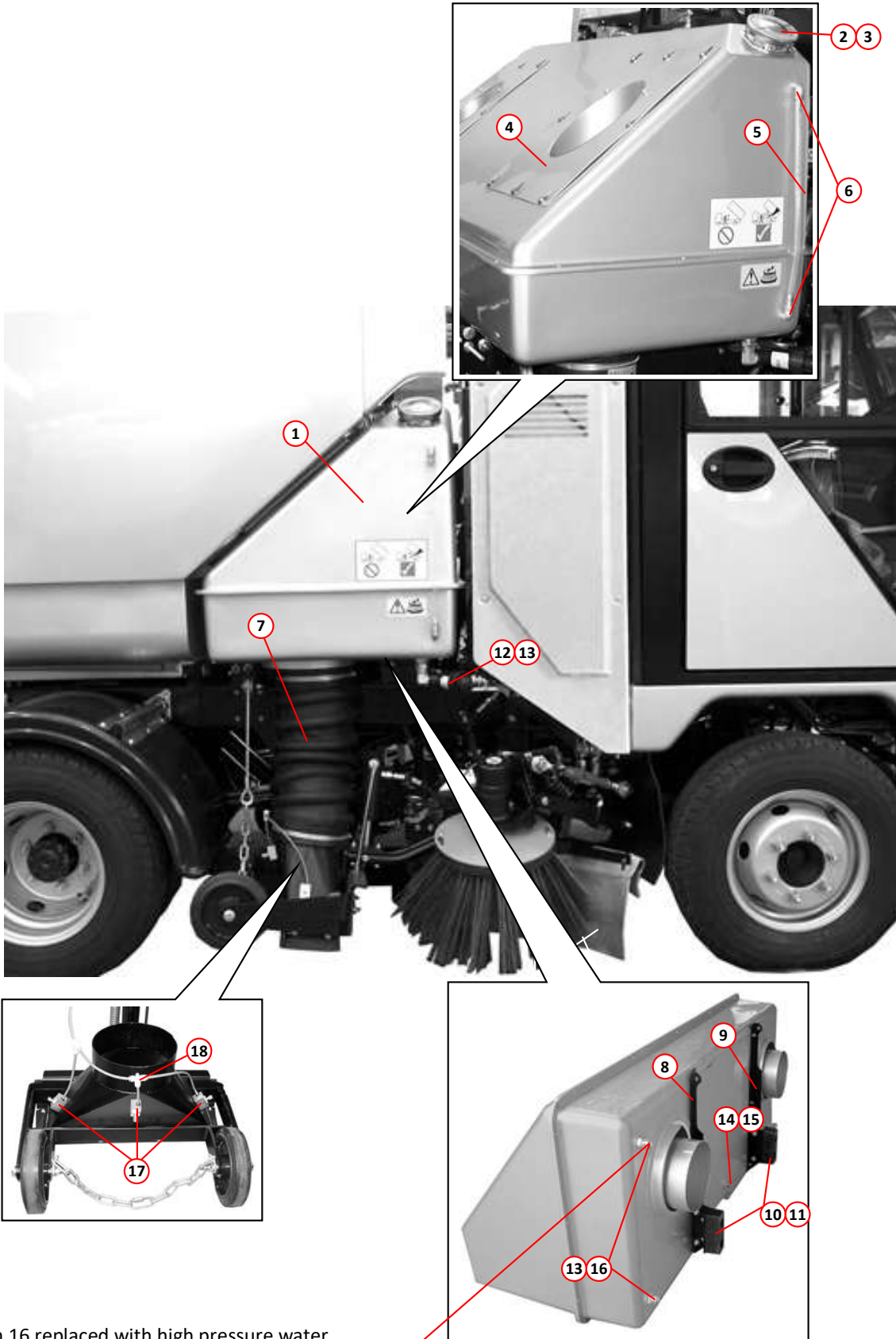

Item 16 replaced with high pressure water filter (Page 168), when high pressure pump is fitted

WATER TANK ARRANGEMENT

<i>Item</i>	<i>Part Number</i>	<i>Quantity</i>	<i>Description</i>
Hydrant Filler Kit and Mounting Items			
1	020484	2	Bracket, standpipe mounting
NI	036248*	1	. Locking plate , to enable fitment of padlock to secure item 3
	011010	4	. Bolt, M8 x 20mm
	011073	5	. Nut, M8
2	020483	2	. Strap, Standpipe mounting
	000021	2	. . Bolt, M6 x 40mm
	011071	2	. . Nut, M6, Nyloc
3	010509	2	. Catch
	011002	4	. . Screw M6 x 16mm
	011071	2	. . Nut, M6, Nyloc
4	014547	1	Hydrant hose
5	013171	1	. Hydrant hose tail
6	014546	1	. Hydrant male Insert
7	014544	1	Hydrant standpipe
8	014545	1	Hydrant key and bar
9	013840	1	Filler cap assembly
10	013169	1	. Hydrant thread adaptor
11	010918	1	. . Elbow, M/F, galvanised, $\frac{3}{4}$ " BSP
	011104	1	. . Washer, 1

Notes:-

* Optional if lockable stowage is required.

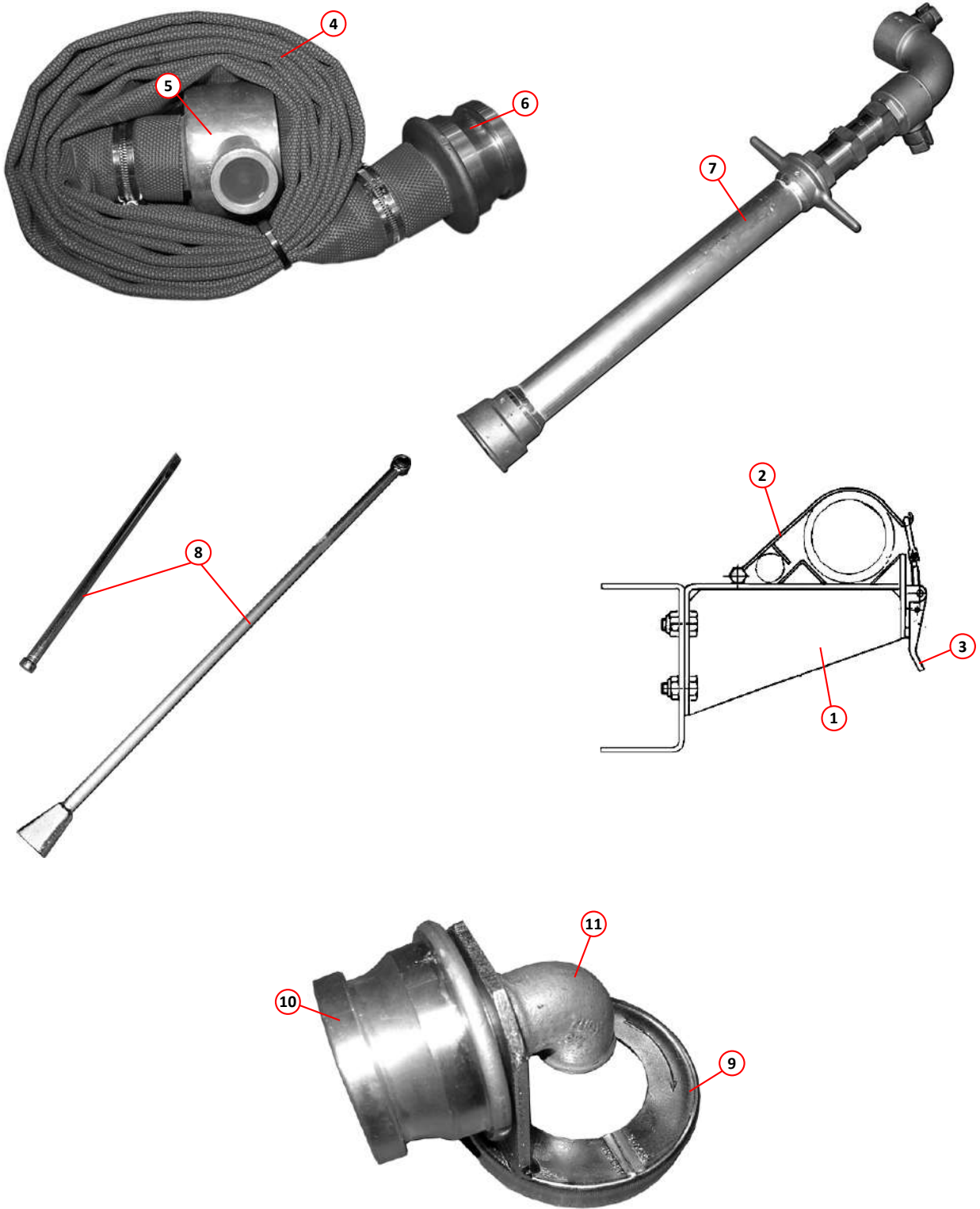

HYDRANT MOUNTING PARTS & MOUNTING ITEMS

Item	Part Number	Quantity	Description
Low Pressure Water Pump Assembly			
1	037160	1	Water services hanger plate Page 52
2	037161	1	. Bracket, water services, hanger plate, rear
	011075	4	. . Nut, M8, Nyloc
3	037162	1	. Bracket, water services, hanger plate, front
	011075	4	. . Nut, M8, Nyloc
4	026866	1	. Electric water pump Page 50,223
	011001	4	. . Setscrew, M6 x 20mm
	011090	4	. . Washer, M6
NI	026723	1	. . Elbow (suction)
NI	002108	AR	. . Hose, plastic reinforced, $\frac{3}{4}$ " bore
5	031510	1	. . Tee, plastic
NI	010518	4	. . . Clamp, worm drive, 30-40mm
6	026723	1	. . Elbow (delivery)
NI	001015	AR	. . Hose, rubber 12mm bore
NI	010516	2	. . . Clamp, worm drive, 11-16mm
NI	028176	1	. Blanking flange
	026891	1	. Diaphragm replacement kit
	026892	1	. Valve replacement kit

Item	Part Number	Quantity	Description
Water Valve Arrangement			
1	040877	1	Water valve 12 Volt, 3 way (complete, less fittings)
NI	040879	1	Water valve 12 Volt, 4 way (complete, less fittings)
NI	040881	1	Water valve 12 Volt, 5 way (complete, less fittings)
	000052	4	. . Setscrew, M5 x 16mm
2	034627	AR	. Solenoid, + coil 12 Volt
3	034626	AR	. Coil, 12 Volt, 8 Watts
4	011159	2	. Adaptor, M/M, $\frac{1}{2}$ " BSP
	011153	2	. . Seal, Dowty, $\frac{1}{2}$ "
5	011205	1	. Elbow, F/F, $\frac{3}{8}$ " BSP
6	010914	1	. Adaptor, F/F, $\frac{1}{2}$ " x $\frac{3}{8}$ " BSP
7	011172	1	. Elbow, M/F, $\frac{3}{8}$ " BSP
8	026869	1	. Hose tail, $\frac{3}{8}$ " BSP x $\frac{1}{2}$ " hose
9	010914	1	. Adaptor, M/M, $\frac{1}{2}$ " x $\frac{3}{8}$ " BSP
10	030741	1	. Pressure regulating valve
11	025181	1	. Hose tail, $\frac{1}{2}$ " BSP x $\frac{3}{4}$ " hose
6	041031	AR	. . Tube, nylon, \varnothing 10mm (blue)
NI	035733	AR	. . Tube, nylon, \varnothing 6mm (blue)
NI	034624	AR	. Diaphragm replacement kit
NI	041030	AR	. Tee, 10mm equal, push-in
NI	041029	AR	. Adaptor, 10mm to 6mm, push-in

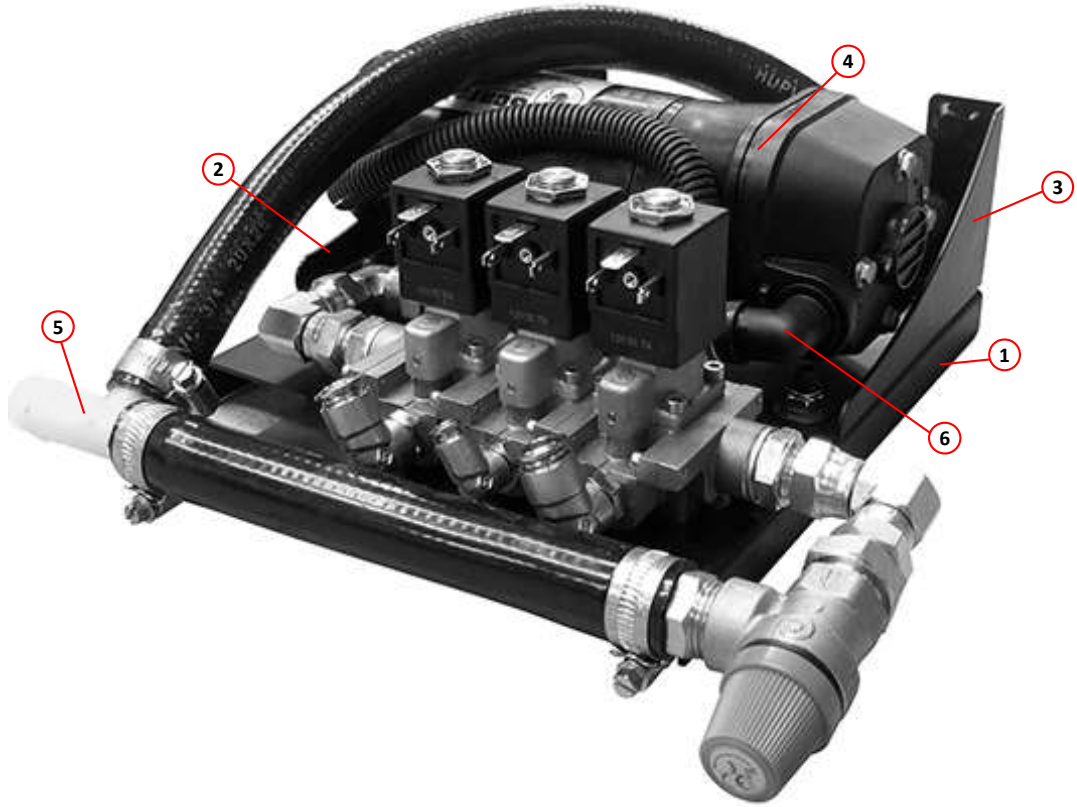

LOW PRESSURE WATER PUMP ASSEMBLY

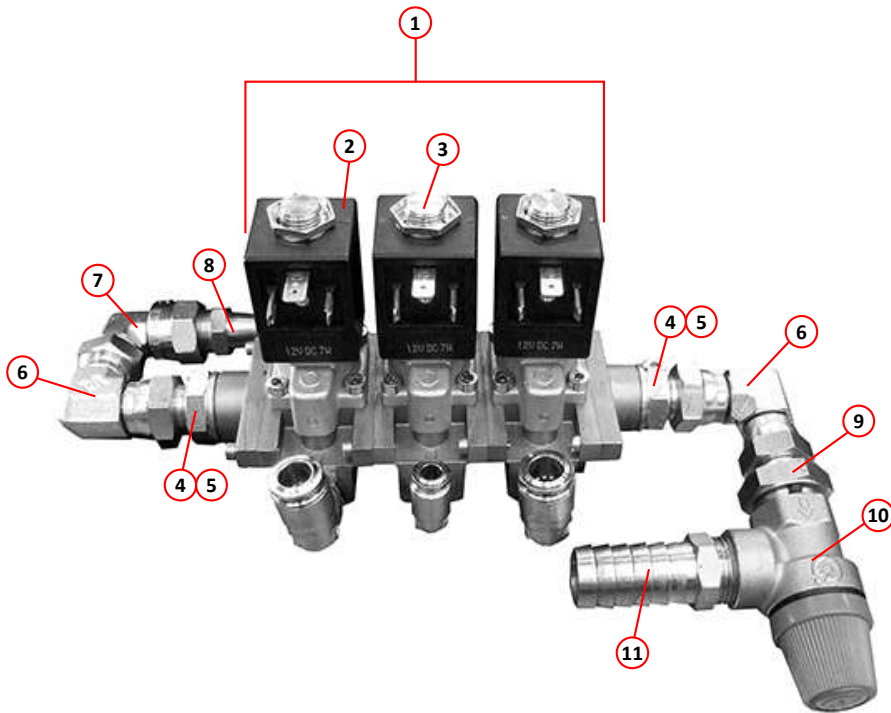

WATER VALVE ARRANGEMENT

<i>Item</i>	<i>Part Number</i>	<i>Quantity</i>	<i>Description</i>
			Low Pressure Water Filter Assembly
	025290	1	Filter assembly complete with elbow, reducing bush and hose tail
1	010121	1	Filter, water strainer
2	010962	1	. Reducing bush, M/F, $\frac{3}{4}$ " to $\frac{1}{2}$ " BSP
3	025181	1	. . Hose tail, $\frac{1}{2}$ " BSP to $\frac{3}{4}$ " hose
4	011174	1	. Elbow, swivel, M/F, $\frac{3}{4}$ " BSP

<i>Item</i>	<i>Part Number</i>	<i>Quantity</i>	<i>Description</i>
			6 Nozzle Low Pressure Spray Bar Assembly
1	040809	1	Spray bar, 6 nozzles, plastic (complete)
2	031417	2	Clamp
	011031	4	. Setscrew, M10 x 25mm
	011075	4	. Nut, M10, Nyloc
3	040810	1	Mounting bracket
4	028761		Carrier Page 160
5	041029	1	Adaptor, $\frac{1}{2}$ " BSPP to 10mm push-In
6	041031	AR	Tube, nylon, \varnothing 10mm (blue)
7	030633	3	Filter
8	030636	3	Washer, rubber
9	030637	3	Spray jet (red)
10	030746	3	Nozzle cap

<i>Item</i>	<i>Part Number</i>	<i>Quantity</i>	<i>Description</i>
			3 Nozzle Low Pressure Spray Bar Assembly
1	030203	1	Spray bar, 3 nozzles, plastic (complete)
2	031418	3	Nozzle holder
3	030636	3	Washer, rubber
4	030633	3	Filter
5	030637	3	Spray jet (red)
6	030635	3	Nozzle cap
7	031417	2	Clamp
8	031995	1	Adaptor, $\frac{1}{4}$ " BSP female x 6mm tube, push-in
NI	035773	AR	Tube, plastic, 6mm (blue)
9	028761	1	Carrier Page 160
	011031	4	Setscrew, M10 x 25mm
	011075	4	Nut, M10, Nyloc



WATER FILTER ASSEMBLY

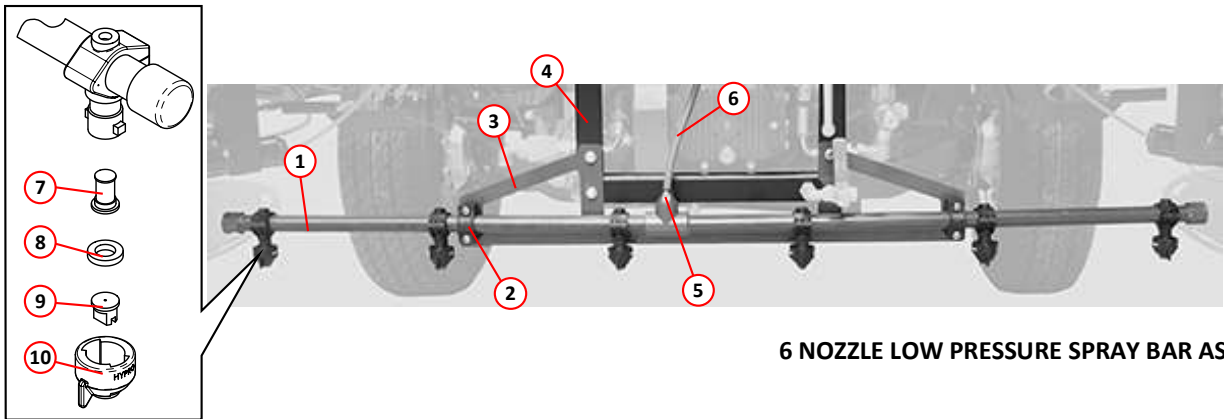

6 NOZZLE LOW PRESSURE SPRAY BAR ASSEMBLY

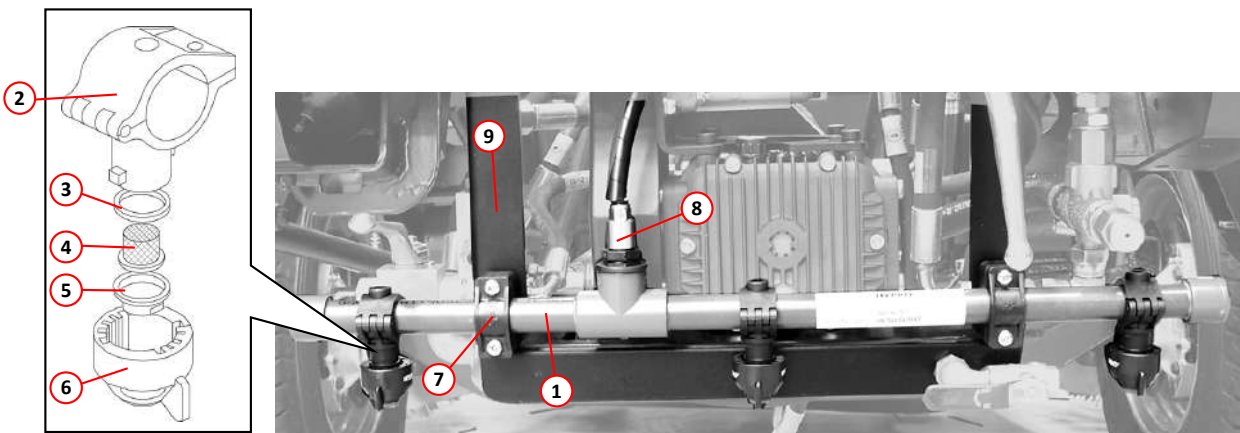

3 NOZZLE LOW PRESSURE SPRAY BAR ASSEMBLY

<i>Item</i>	<i>Part Number</i>	<i>Quantity</i>	<i>Description</i>
Low Pressure Water Spray Jet, Front and Side Brush			
1	031995	1	Adaptor, $\frac{1}{4}$ " BSP female x 6mm tube, push fit
2	035668	1	. Nozzle mount, LH
NI	035667	1	. Nozzle mount, RH
3	010922	1	. Hose tail, $\frac{1}{4}$ " BSP male x $\frac{3}{8}$ " tube
4	030663	1	. Hose, rubber, $\frac{3}{8}$ " x 120mm
5	030747	1	. Elbow, nozzle
6	030636	1	. Washer, rubber
7	030748	1	. Spray jet (blue)
8	030746	1	. Nozzle cap
9	030633	1	. Filter
10	031072	1	. O-Clip 15/18
11	033433	1	. . Valve, ball, $\frac{1}{4}$ " BSP

<i>Item</i>	<i>Part Number</i>	<i>Quantity</i>	<i>Description</i>
Low Pressure Water Spray Jet, Fixed Type			
1	023203	1	Elbow, $\frac{1}{4}$ " BSP male x 6mm tube, push fit
2	030892	1	Bracket, spray nozzle (fixed)
3	033433	1	Valve, ball, $\frac{1}{4}$ " BSP
4	030769	1	Nozzle body, straight
5	030636	1	Washer rubber
6	030633	1	Filter
7	030748	1	Spray jet
8	030746	1	Nozzle cap

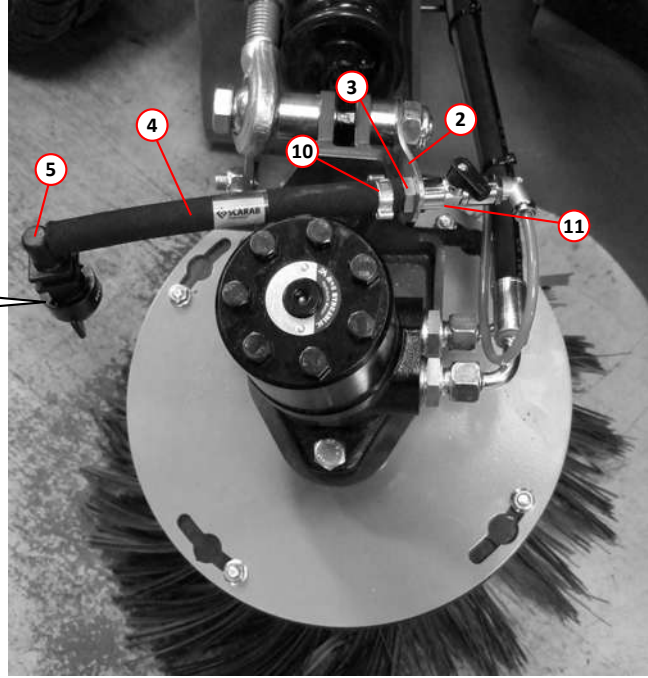
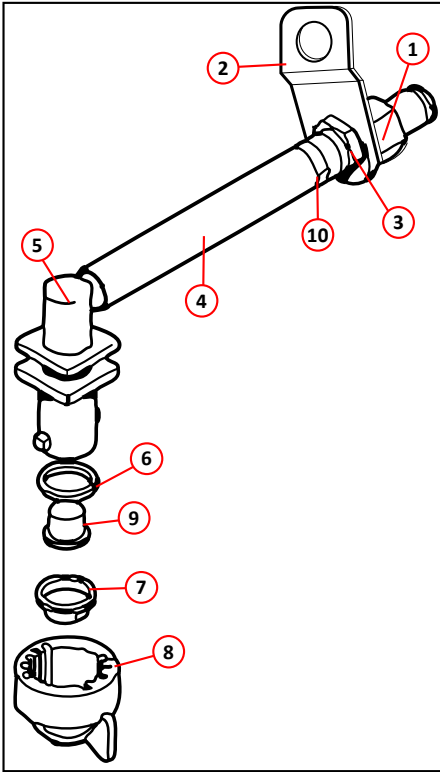

WATER SPRAY JET - FRONT AND SIDE BRUSH

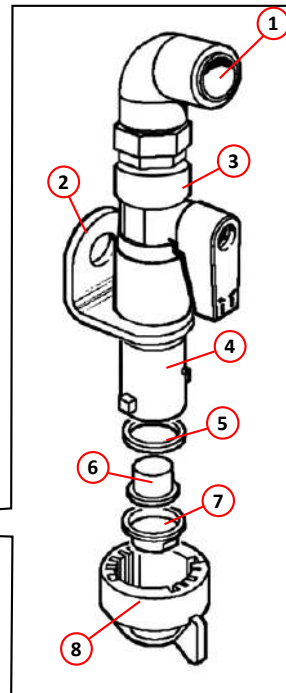

WATER SPRAY JET - FIXED TYPE

Item	Part Number	Quantity	Description
High Pressure Water Pump - Arrangement			
1	028761	1	Carrier Page 156
2	014449	1	. Motor bracket
3	021315	1	. Motor, hydraulic, 15cc, 1MR015 Page 196
4	014867	1	. Pump, High-pressure, RK21.15HN
	000136	8	. . Screw, socket cap head, M8 x 16mm
	011068	4	. . Setscrew, M6 x 35mm
	011090	4	. . Washer, M6
	011071	4	. . Nut, M6, Nyloc
5	034308	1	. High pressure spray bar hose
6	011199	1	. Adaptor, M/M, $\frac{1}{4}$ " BSP
7	011152	1	. . Seal, Dowty, $\frac{1}{4}$ " BSP
8	011257	1	. Valve, ball, $\frac{1}{4}$ " BSP
9	011199	3	. Adaptor, M/M, $\frac{3}{8}$ " x $\frac{1}{4}$ " BSP
10	011223	1	. Tee, swivel, M/M/F, $\frac{3}{8}$ " BSP
11	011205	2	. Elbow, swivel, F/F, $\frac{3}{8}$ " BSP
12	011159	2	. Adaptor, M/M, $\frac{3}{8}$ " BSP
13	011153	1	. . Seal, Dowty, $\frac{3}{8}$ " BSP
14	010599	1	. Valve, unloader
15	002008	1	. Adaptor, bulkhead, M/M, $\frac{3}{8}$ " BSP
16	011135	1	. . Washer, M16
17	010930	2	. Hose tail, $\frac{3}{8}$ " BSP x $\frac{5}{8}$ " tube
18	011743	1	. Valve, ball, $\frac{1}{4}$ " BSP
19	010910	2	. Elbow, galvanised, M/F, $\frac{1}{4}$ " BSP
20	011269	2	. Adaptor, bulkhead, M/M, $\frac{1}{4}$ " BSP
21	014455	1	. Drive belt cover
	011090	2	. . Washer, M6
	011071	2	. . Nut, M6, Nyloc
22	001121	1	. Hose, rubber, $\frac{1}{4}$ " BSP x 270mm, straight and 90° ends
23	025599	1	. Power steering regulator valve Page 196
24	010959	1	. Tube, rubber, 1" bore
	010518	2	. . Clamp, worm drive, 30-40mm
25	001148	1	. Hose rubber, $\frac{3}{8}$ " BSP x 400mm, 90° ends
26	011000	1	. Tube, rubber, $\frac{5}{8}$ " bore x 450mm
	010517	2	. . Hose clamp, worm drive, 18-25mm
27	001243	1	. Hose, rubber, $\frac{1}{4}$ " BSP
28	010931	1	. Hose tail, $\frac{3}{4}$ " x 1" hose
29	010917	1	. Elbow, galvanised, M/F, $\frac{3}{4}$ " BSP
30	010919	1	. Tee, galvanised, M/M/M, $\frac{3}{4}$ " BSP
31	010946	1	. Adaptor, reducing, galvanised, M/F, $\frac{3}{4}$ " x $\frac{3}{8}$ " BSP
32	010962	1	. Adaptor, reducing, galvanised, M/F, $\frac{3}{4}$ " x $\frac{1}{2}$ " BSP
33	011173	1	. Elbow, swivel, M/F, $\frac{1}{2}$ " BSP
34	011160	1	. Adaptor, M/M, $\frac{1}{2}$ " BSP
35	011154	4	. . Seal, Dowty, $\frac{1}{2}$ " BSP
36	011165	1	. Adaptor, M/M, $\frac{1}{2}$ " x $\frac{1}{4}$ " BSP
37	014703	1	. Pulley, toothed, 40-8-20
38	014453	1	. . Taper lock bush, 1610 x 24
	011994	2	. . Key, rectangular, 8 x 6 x 25 round ends
	014447	1	. . Sleeve
39	014454	1	. Belt, toothed, 560mm long
40	012529	1	. Pulley, toothed, 32-8-20
41	010575	1	. . Taper lock bush, 1610 x 30
	000068	1	. . . Washer, $\frac{7}{16}$ "
	000014	1	. . . Nut, $\frac{7}{16}$ " UNF, Nyloc

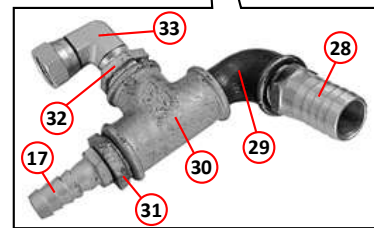
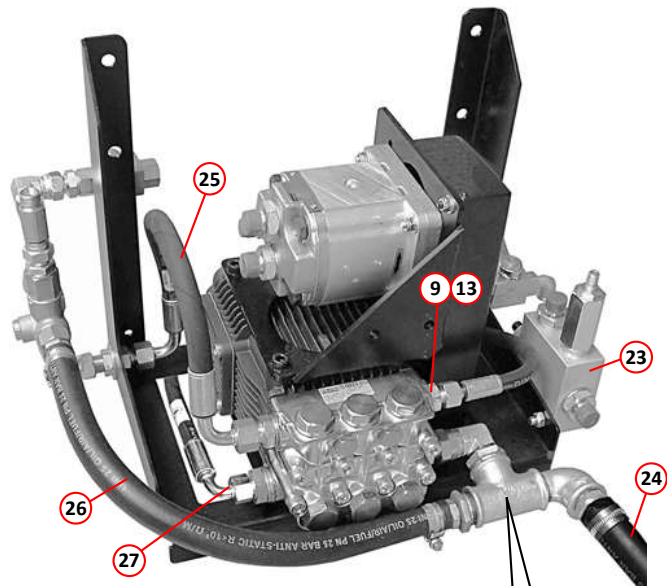
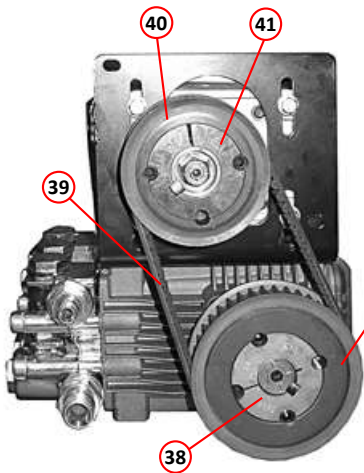
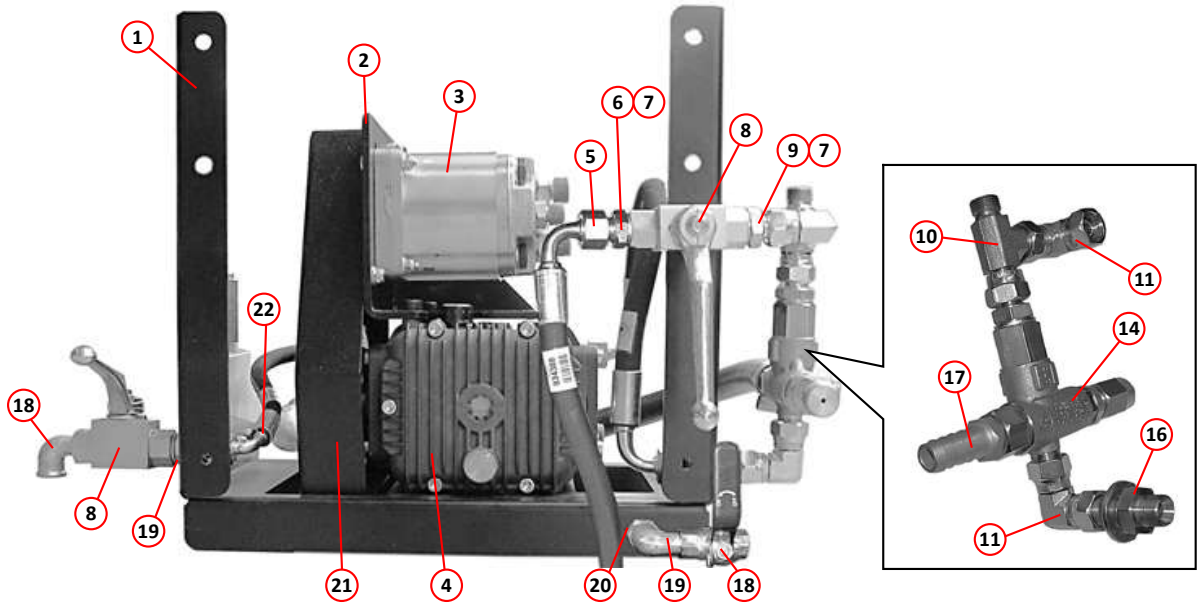

HIGH PRESSURE WATER PUMP - ARRANGEMENT

<i>Item</i>	<i>Part Number</i>	<i>Quantity</i>	<i>Description</i>
High Pressure Water Pump - Components			
1	014867	1	Pump 21 litre high pressure (RK21.15HN)
2	014867SE	1	Pump 21 litre high pressure (service exchange unit)
3	013554	1	Poppet Valve Kit 1828
4	014462	1	Water Valve Kit 1855
5	021237	1	Water Seal Kit 1888
6	021236	6	Seal, O-ring
7	021238	1	Head
8	021268	6	Valve plug
9	021239	2	Plug
10	021240	2	Seal, O-ring
11	021241	3	Bearing gasket $\varnothing 22$
12	021242	3	Piston guide bush
13	021243	1	Closed bearing support
14	028705	2	Bearing
15	021245	1	Pump body complete with end cap and O-ring for end cap
16	021246	1	Oil filler plug
17	021247	3	Piston seal nut
18	021248	3	Washer
19	021249	3	Piston, $\varnothing 22$
20	021250	3	Separation disc
21	021251	3	Seal, O-ring
22	021252	3	Drive piston
23	021253	3	Pin
24	021254	3	Connecting rod
25	021255	1	Circlip
26	021256	1	Oil level plug
27	021257	1	O-ring
28	021258	1	Rear cap
29	021259	1	Eccentric shaft
30	021260	1	Key
31	021261	1	Plug
32	021262	1	Open bearing support
33	021263	2	O-Ring
34	021264	1	Plug
35	021265	1	Seal, O-ring
36	021266	1	Lining 0.1
36	021267	1	Lining 0.2
37	014448	2	Bracket, mounting

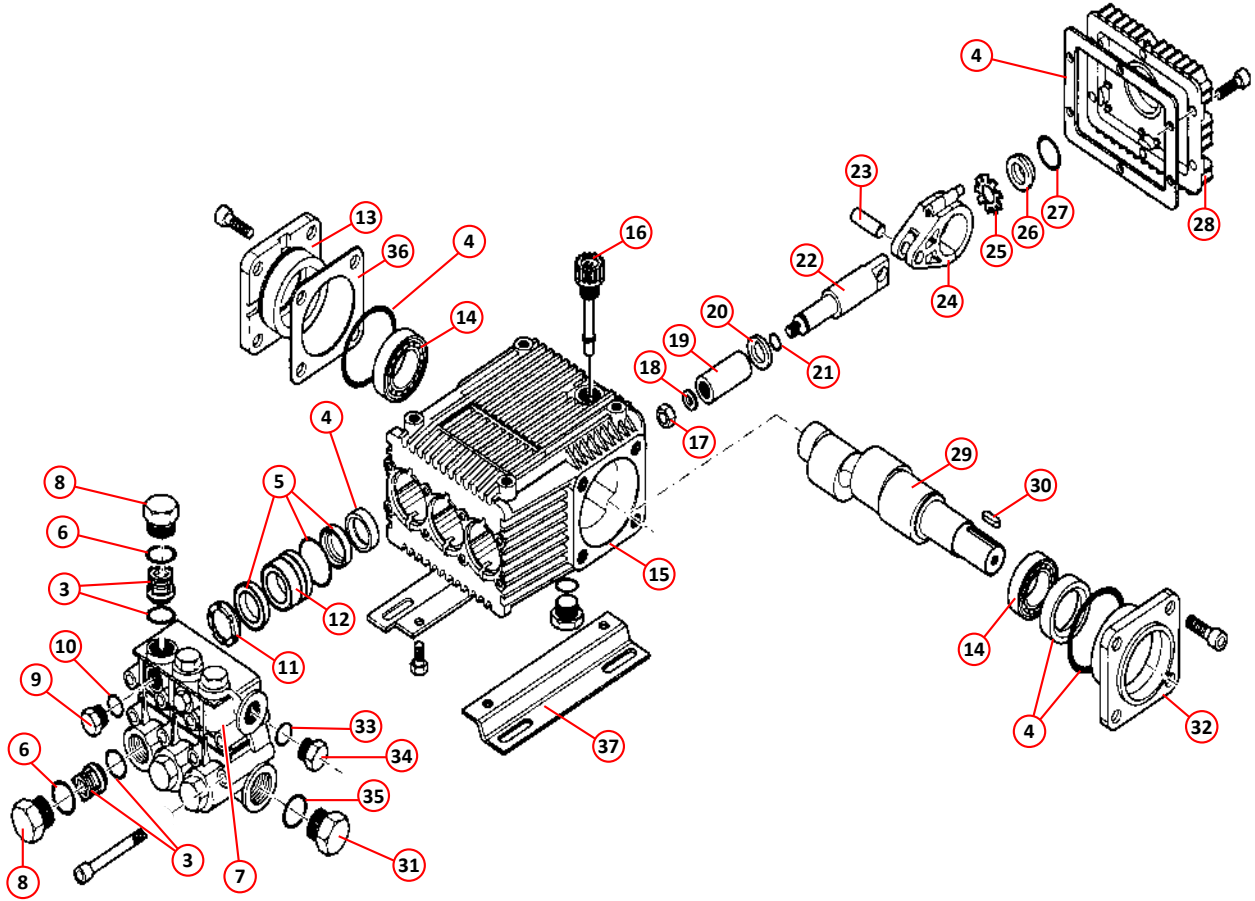

HIGH PRESSURE WATER PUMP - COMPONENTS

<i>Item</i>	<i>Part Number</i>	<i>Quantity</i>	<i>Description</i>
High Pressure Water Hose End Stowage Arrangement			
	020451	1	Automatic Hose Reel Page 168
1	012548	1	Bracket, quick release coupling support
	011011	1	. Setscrew, M8 x 25mm
	011073	1	. Nut, M8, Nyloc
2	002008	1	. Adaptor, bulkhead, M/M, $\frac{3}{8}$ " BSP
3	023359	1	. Coupling, quick release, $\frac{3}{8}$ " BSP, (male)
4	023360	1	. . Coupling, quick release, $\frac{3}{8}$ " BSP, (female)
5	011159	1	. . . Adaptor, M/M, $\frac{3}{8}$ " BSP
6	011167	1	. . . Seal, dowty, $\frac{3}{8}$ " BSP
7	011167	1	. Adaptor, M/M, $\frac{3}{8}$ " x $\frac{1}{2}$ " BSP

<i>Item</i>	<i>Part Number</i>	<i>Quantity</i>	<i>Description</i>
Detergent Feed Valve (Hand Lance)			
8	013573	1	Nozzle injector
9	002173	1	. Adaptor, M/F, $\frac{3}{8}$ " BSP
10	011214	1	. Adaptor, F/F, $\frac{3}{8}$ " BSP
11	011167	1	. Adaptor, M/M, $\frac{3}{8}$ " x $\frac{1}{2}$ " BSP
12	013575	AR	. Tube, silicon

<i>Item</i>	<i>Part Number</i>	<i>Quantity</i>	<i>Description</i>
Detergent Bottle and Feed Valve (Water Boom)			
13	012548	1	Bracket, valve support
	011010	1	. Setscrew, M8 x 25mm
	011073	1	. Nut, M8, Nyloc
14	010393	1	Bracket, bottle support
NI	022451	4	. Spacer
	011410	4	. . Bolt, M8 x 75mm
	011073	4	. . Nut, M8, Nyloc
15	013553	1	. Bottle, detergent
16	013575	AR	. Tube, silicon
17	013575	1	. . Strap, bungee
18	013573	1	Nozzle, injector
19	011214	1	. Adaptor, F/F, $\frac{3}{8}$ " BSP
20	002008	1	. Adaptor, bulkhead, M/M, $\frac{3}{8}$ " BSP
21	011171	1	. Elbow, swivel, M/F, $\frac{3}{8}$ " BSP

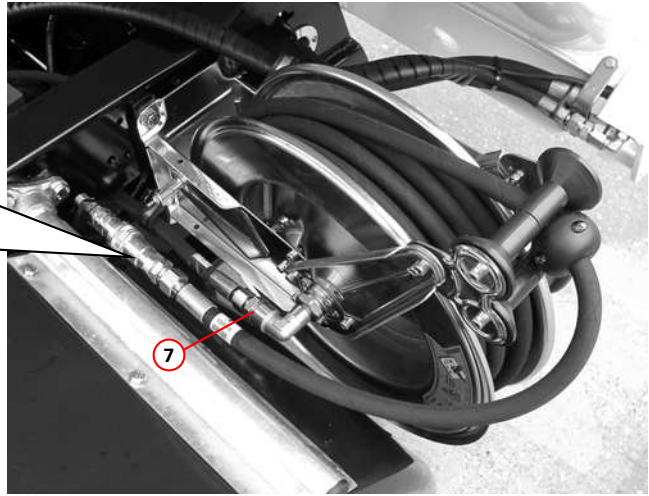
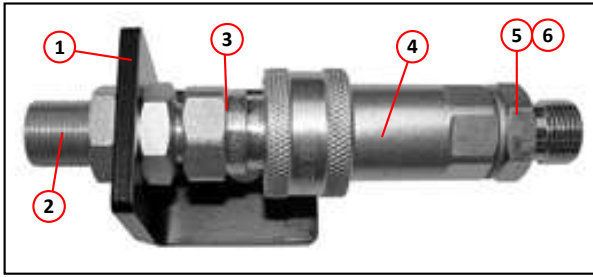

HIGH PRESSURE WATER HOSE END STORAGE ARRANGEMENT

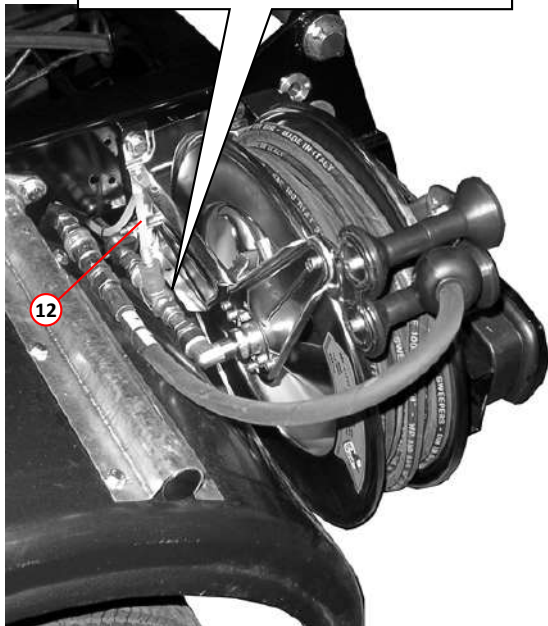
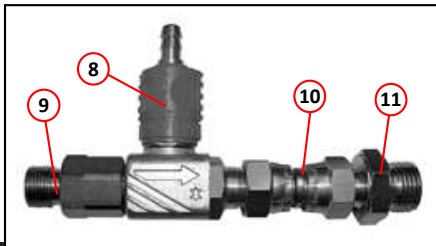

DETERGENT FEED VALVE (HAND LANCE)

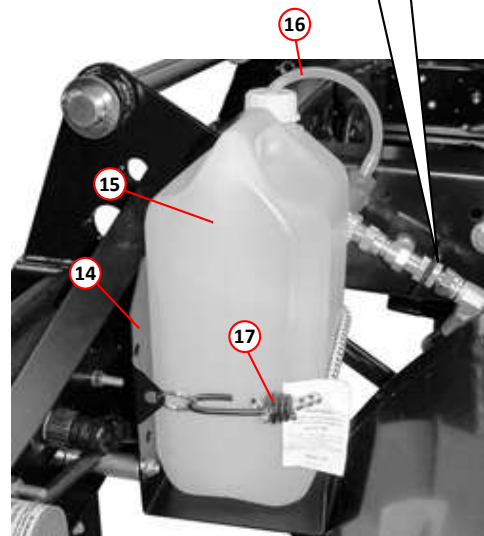
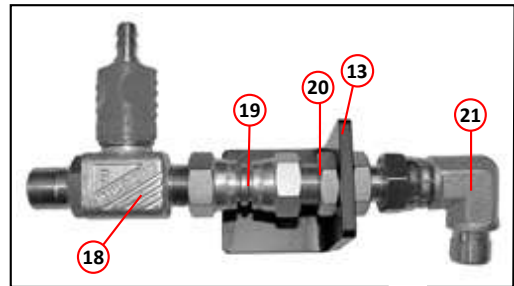

DETERGENT BOTTLE AND FEED VALVE (WATER BOOM)

Item	Part Number	Quantity	Description
			Fan Wash Assist Arrangement
	020451	1	Automatic Hose Reel Page 168
1	011233	1	Tee, $\frac{3}{8}$ " BSP, M/M/F
2	011167	1	. Adaptor, M/M, $\frac{3}{8}$ " x $\frac{1}{2}$ " BSP
3	011171	1	. Elbow, swivel, M/F, $\frac{3}{8}$ " BSP
4	011309	1	. . Hose, 432mm x $\frac{3}{8}$ " BSP, straight ends
5	011199	1	. . . Adaptor, M/M, $\frac{3}{8}$ " x $\frac{1}{4}$ " BSP
	011152	1 Seal, dowty, $\frac{1}{4}$ " BSP
6	011257	1 Valve, ball, F/F, $\frac{1}{4}$ " BSP
	011152	1 Seal, dowty, $\frac{1}{4}$ " BSP
7	011269	1 Adaptor, bulkhead, M/M, $\frac{1}{4}$ " BSP
	011096	2 Washer, M12
8	012548	1 Bracket, ball valve support
	011010	1 Setscrew, M8 x 25mm
	011073	1 Nut, M8, Nyloc
9	001002	1	Hose, 3700mm x $\frac{3}{8}$ " BSP, straight ends
10	011172	1	. Elbow, swivel, M/F, $\frac{1}{4}$ " BSP
11	011269	1	. . Adaptor, bulkhead, $\frac{1}{4}$ " BSP
	011096	2	. . . Washer, M12
12	011172	1	. . Elbow, swivel, M/F, $\frac{1}{4}$ " BSP
13	011317	1	. . . Hose, 295mm x $\frac{1}{4}$ " BSP
12	011172	1 Elbow, swivel, M/F, $\frac{1}{4}$ " BSP
15	011269	1 Adaptor, bulkhead, $\frac{1}{4}$ " BSP
	011096	2 Washer, M12
16	010911	1 Boss, $\frac{1}{4}$ " BSP
17	011158	1 Adaptor, M/M, $\frac{1}{4}$ " BSP
18	010912	1 Elbow, galvanised, F/F, $\frac{1}{4}$ " BSP
19	030507	1 Spray jet assembly, LF6-80

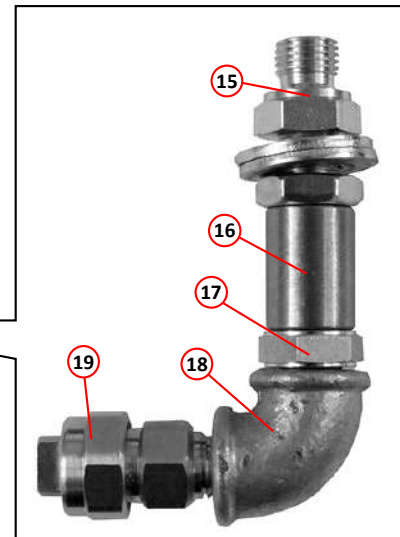
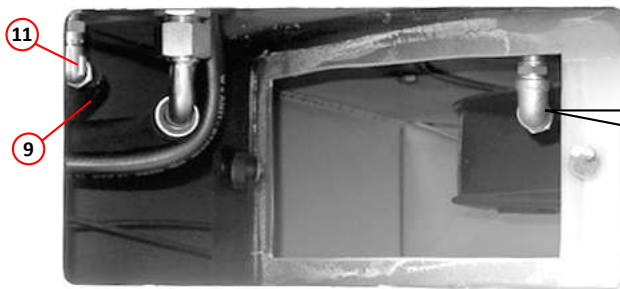
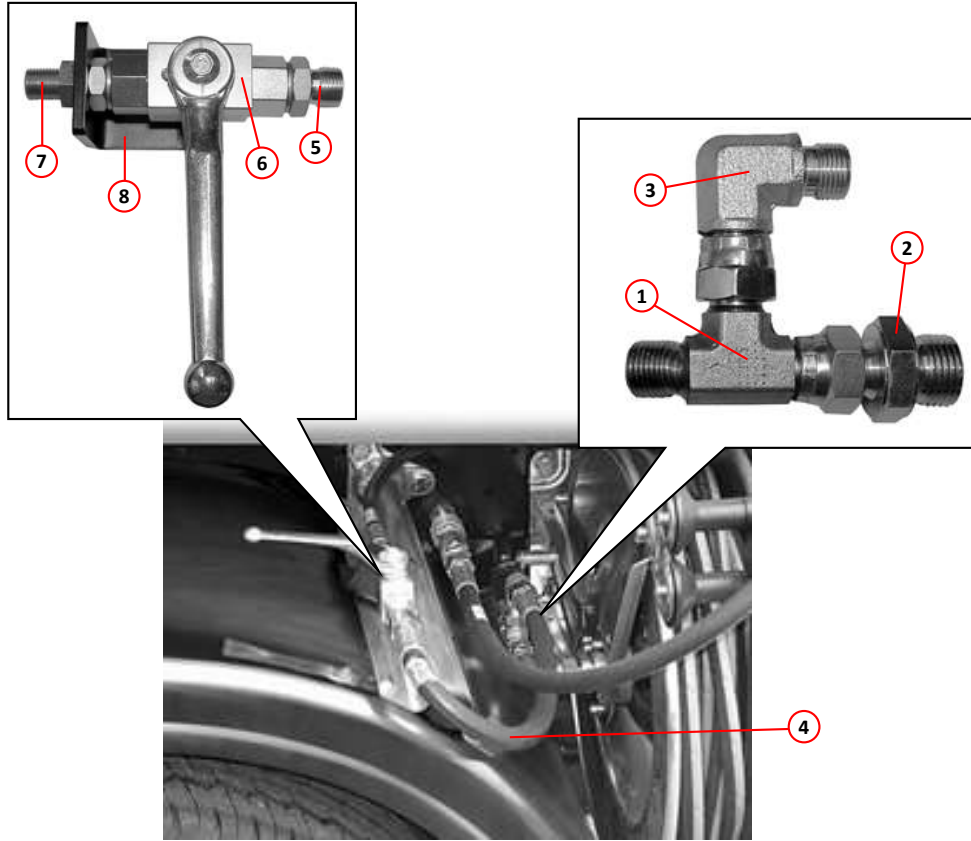

FAN WASH ASSIST ARRANGEMENT

<i>Item</i>	<i>Part Number</i>	<i>Quantity</i>	<i>Description</i>
High Pressure Spray System - Layout			
1	015017	1	. High pressure pump assembly Page 160,172
2	028761	1	. . Carrier, high-pressure pump (located behind front spray bar)
3	010748	1	. Lance, (mounted in cab, beneath front of seats) Page 90
NI	014666	1	. . Jet for lance
4	011159	1	. . Adapter, M/M, $\frac{3}{8}$ " BSP
5	024463	1	. . . Swivel joint
	025290	1	Filter assembly complete with elbow and hose tail
6	010121	1	. Filter, water strainer
7	011174	1	. . Elbow
8	010931	1	. . Adaptor $\frac{3}{4}$ " BSP x 1" hose tail
9	010959	1.4 m	. . Hose
	010518	2	. . . Clamp, worm drive, 30-40mm
10	011301	1	. . Hose assembly
NI	020451	1	. Hose reel, automatic

<i>Item</i>	<i>Part Number</i>	<i>Quantity</i>	<i>Description</i>
Automatic Hose Reel - Components			
1	020451	1	Automatic hose reel, complete, less hose Page 164,166
2	024230	1	. Swivel elbow assembly
3	025238	1	. . Roller assembly
4	026217	1	. . Clamp
5	026753	1	. . Spring, coiled (used on stainless steel reels only)
6	026754	1	. . Spring, tension
NI	010601	13.0m	. . Hose, reinforced
7	030570	1	. . Ratchet

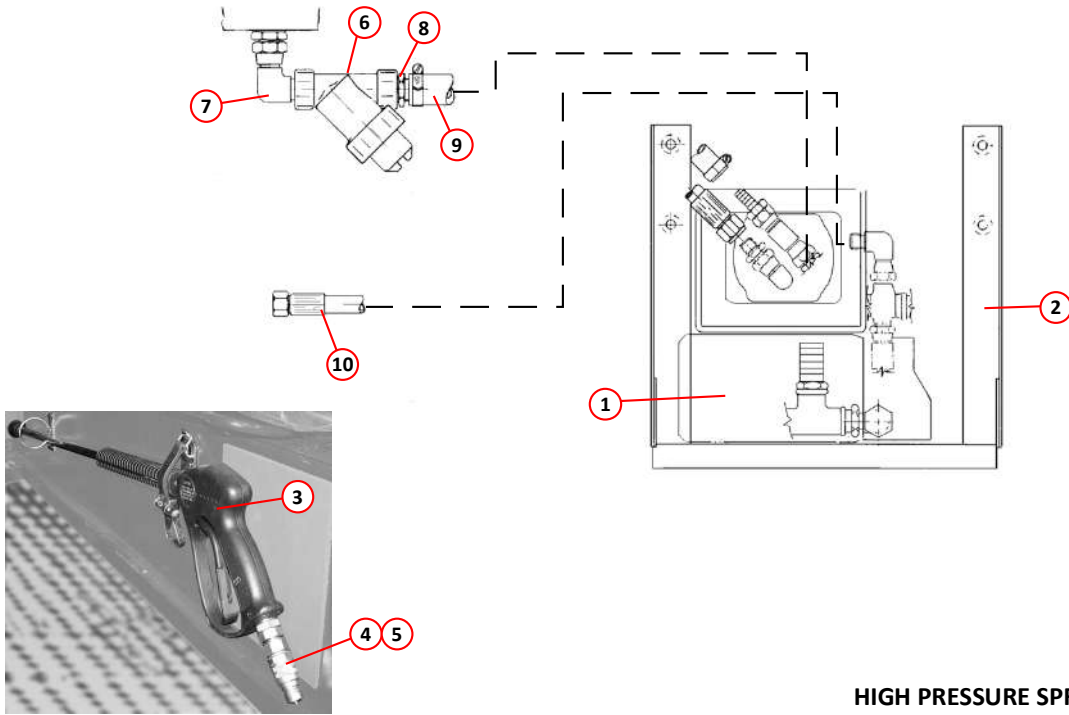

HIGH PRESSURE SPRAY SYSTEM - LAYOUT

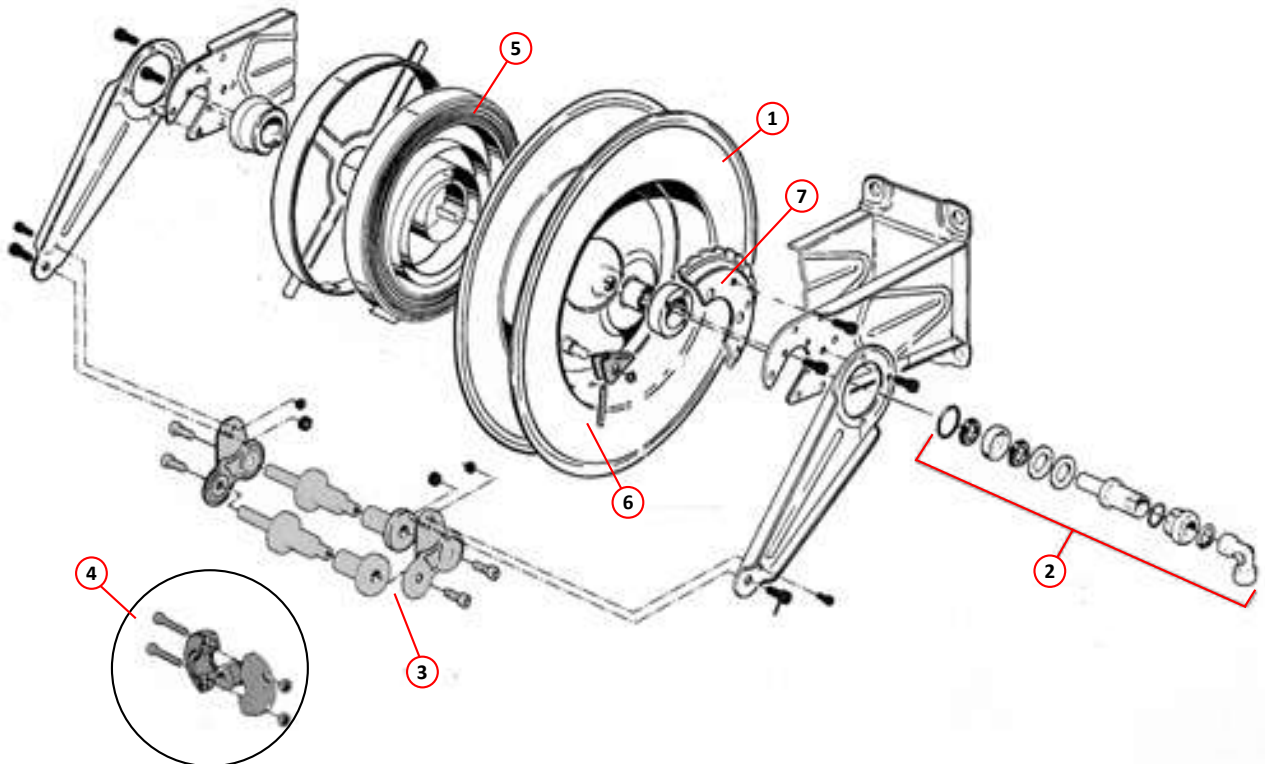

AUTOMATIC HOSE REEL - COMPONENTS

Item	Part Number	Quantity	Description
High Pressure Water Boom Arrangement			
1	027952	1	Carrier, hose reel
	014796	1	. Bolt, pivot
	010903	1	. . Greasing point, straight, $\frac{1}{8}$ " BSP
	011060	1	. Nut, M16, Nyloc
	011135	2	. Washer, M16
NI	013012	2	. Bush
NI	014799	2	. Spacer sleeve
2	023538	1	. Hose reel, retracting
	000205	4	. . Setscrew, M14 x 25mm
	011127	4	. . Nut, M14, Nyloc
3	011160	1	. . Adaptor, M/M, $\frac{1}{2}$ " BSP
4	027945	1	. Main Support Post (universal joint)
5	010903	1	. . Greasing point, straight, $\frac{1}{8}$ " BSP
6	011173	1	. . Elbow, swivel, $\frac{1}{2}$ " BSP
NI	011154	1	. . . Seal, Dowty, $\frac{1}{2}$ " BSP
7	011160	1	. . . Adaptor, M/M, $\frac{1}{2}$ " BSP
8	010970	1	. . . Hose, rubber, $\frac{1}{2}$ " BSP x 460mm, straight ends
9	027947	1	. Bracket, water boom support
10	010903	2	. . Greasing point, straight, $\frac{1}{8}$ " BSP
11	010422	1	. . Joint, rotating, $\frac{1}{2}$ " BSP
12	011160	1	. . . Adaptor, M/M, $\frac{1}{2}$ " BSP
NI	011154	1	. . . Seal, Dowty, $\frac{1}{2}$ " BSP
13	027950	1	. . Plate, reinforcing
	011032	6	. . . Setscrew, M10 x 30mm
	011075	6	. . . Nut, M10, Nyloc
14	027949	1	. Support bar, hose
NI	011724	9	. . Spacer, 20mm x 12.5mm x 11mm
	011055	3	. . Bolt, M12 x 65mm
	011051	4	. . Setscrew, M12 x 25mm
	011077	7	. . Nut, M12, Nyloc
15	013486	2	. Gas strut
	011075	4	. . Nut, M10, Nyloc
16	027948	1	. Hook, stowage, water boom
	011032	4	. . Setscrew, M10 x 30mm
	011075	4	. . Nut, M10, Nyloc
17	023360	1	. Coupling, quick-release, female, $\frac{3}{8}$ " BSP
18	011159	1	. . Adaptor, M/M, $\frac{3}{8}$ " BSP
NI	011153	1	. . Seal, Dowty, $\frac{3}{8}$ " BSP
19	023359	1	. Coupling, quick-release, male, $\frac{3}{8}$ " BSP
NI	011153	1	. . Seal, Dowty, $\frac{3}{8}$ " BSP
20	011199	1	. . Adaptor, M/M, $\frac{3}{8}$ " BSP x $\frac{1}{4}$ " BSP
21	028155	1	. . Bracket, hose retainer
22	011257	1	. . Valve, ball, high-pressure $\frac{1}{4}$ " BSP
NI	011152	1	. . . Seal, Dowty, $\frac{1}{4}$ " BSP

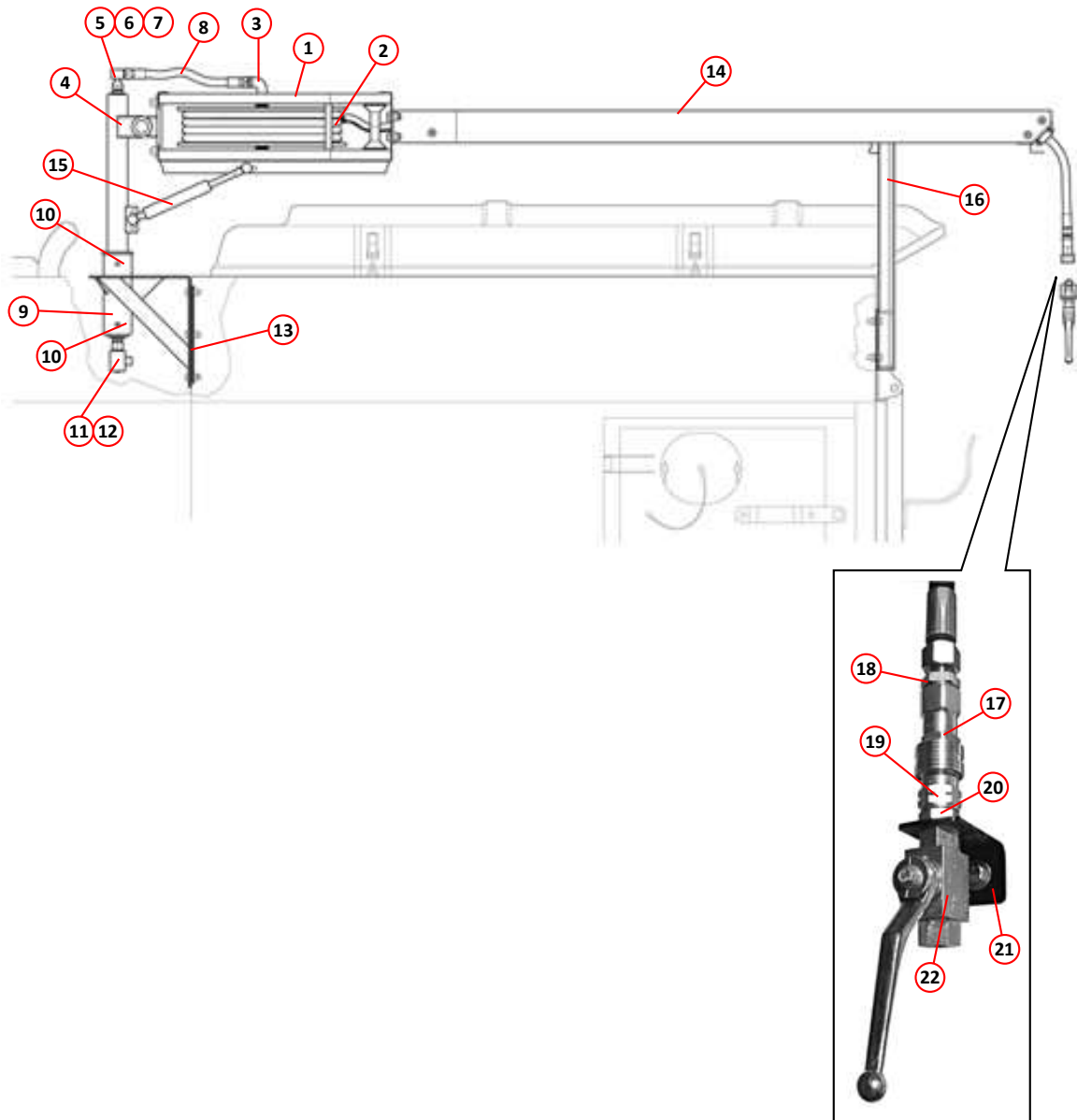

HIGH PRESSURE WATER BOOM ARRANGEMENT

<i>Item</i>	<i>Part Number</i>	<i>Quantity</i>	<i>Description</i>
High Pressure Front Spray Bar Assembly			
1		1	Pump, high pressure, assembly Page 160,168
2	034073	1	Spray bar
3	023148	2	. U-bolt
4	002169	2	. Banjo bolt, $\frac{1}{2}$ " BSP
	011154	2	. . Seal, dowty $\frac{1}{2}$ " BSP
5	010112	5	. Nozzle body (brass)
6	012316	5	. Spray jet LF4-80 (brass)
7	030951	5	. Nozzle cap (brass)

<i>Item</i>	<i>Part Number</i>	<i>Quantity</i>	<i>Description</i>
High Pressure Front Spray Bar Mount			
1	034074	1	Centre pivot
2	028007	1	Clamp plate
3	000299	2	M6 grip nut with insert
4	011071	2	Nut, M6, Nyloc
5	027982	4	Pipe clamp block 25mm single
6	027990	2	Pipe clamp top plate
7	026173	1	Plastic Plug \varnothing 25.4mm (black)

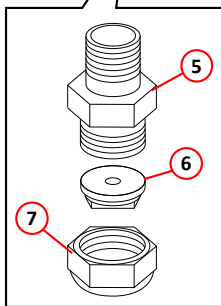
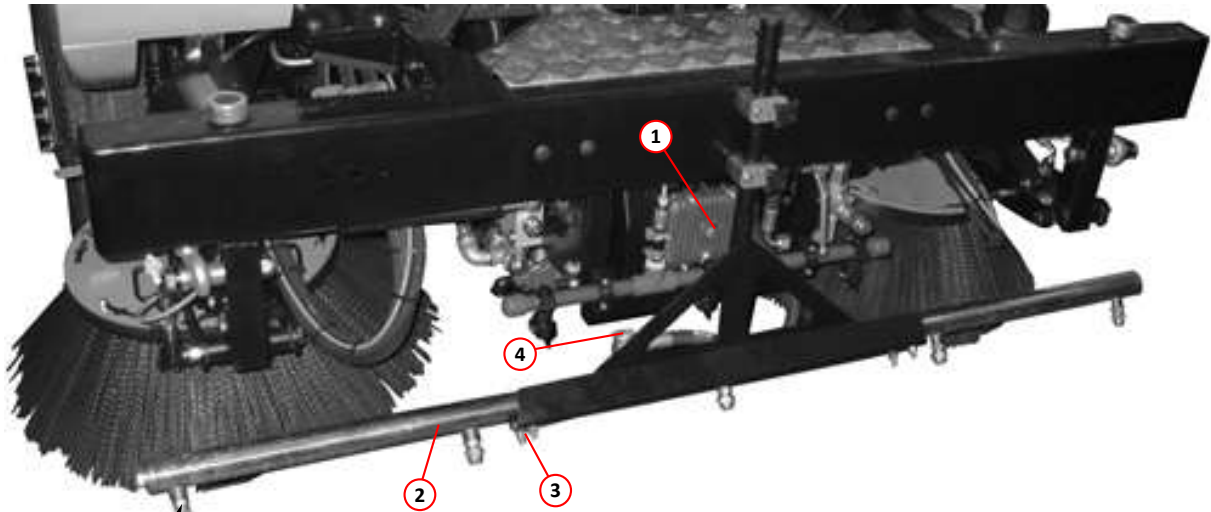

HIGH-PRESSURE FRONT SPRAY BAR

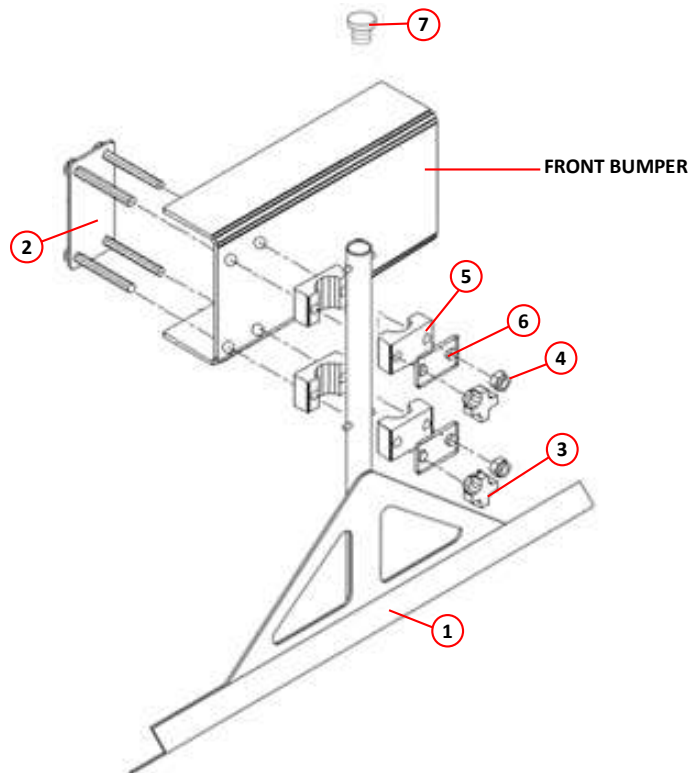

HIGH-PRESSURE FRONT SPRAY BAR MOUNT

Hydraulic Systems

<i>Assembly/Description</i>	<i>Page</i>
Main Control Valve Block (Hydraforce)	176
Brush Control Valve Block (Hydraforce)	178
Main Control Valve Block (pre Hydraforce)	180
Brush Control Valve Block (pre Hydraforce)	182
Front Brush "Stop When Raised" Valve Components	182
Transmission Pump Assembly	184
Suction Fan Pump Assembly	186
Suction Fan Valve Block Assembly (Hydraforce)	186
Suction Fan Motor Assembly	188
Gear Pump Assembly	190
Complete Transmission Assembly	190
Radiator/Cooler Assembly	192
Manifold Assembly	192
Oil Tank Assembly	194
Suction Filter Assembly (Chassis Mounted)	194
Power Steering Regulator Valve	196
Power Steering Regulator Valve (Hydraforce)	196
High Pressure Water Pump Drive Motor	196
Wide Sweep Brush Motor	198
Side/Front Brush Motor	198
Ram - Suction Nozzle Lift	200
Ram - Suction Nozzle Tilt	200
Ram - Wide Sweep Lift	200
Ram - Front Brush Lift	202
Ram - Front Brush Swing Out	202
Ram - Side Brush Lift	202
Ram - Side Brush Swing Out	202
Ram - Hopper Lift	204
Ram - Auto Blanking	204
Ram - Rear Door Open/Close	204
Ram - Cab Lift Assist	204
Rear Door Flow Valve and Pressure Control Assembly (Hydraforce)	206
Rear Door Check Valve (Hydraforce)	206
Rear Door Flow Valve and Pressure Control Assembly	208
Rear Door Check Valve	208
Auto Blanking Valve Single Sweep Assembly	210
Auto Blanking Valve Dual Sweep Assembly	210
Steel Pipes	212
Rubber Hoses - LH Sweep Machines Only	212
Rubber Hoses - RH Sweep Machines Only	213
Rubber Hoses - Dual Sweep Machines Only	213
Rubber Hoses - Common to LH, RH and Dual Sweep Machines	213

<i>I</i> Item	<i>Part Number</i>	<i>Quantity</i>	<i>Description</i>
Main Control Valve Block (Hydraforce)			
1	041227	1	Manifold, main valve block
2	041218	10	. Cartridge (SV08-30)
NI	041246	10	. . Seal kit (SV08-30)
3	041225	12	. .Coil, 12v/17.2 Watt
4	041219	1	. Cartridge (SV08-21)
NI	041247	1	. . Seal kit (SV08-21)
5	041216	1	. Cartridge (SV08-24)
NI	041244	1	. . Seal kit (SV08-24))
6	041217	2	. Cartridge (SV10-47D)
NI	041245	2	. . Seal kit (SV10-47D)
7	041224	4	. . Coil, 12v/20.5 Watt
8	041215	2	. Cartridge (SV10-47C)
NI	041243	2	. . Seal kit (SV10-47C)
9	041221	1	. Relief valve (RV08-20H, 120 Bar)
NI	041249	1	. . Seal kit (RV08-20H)
10	041220	1	. Relief valve (RV10-20H, 170 Bar)
NI	041248	1	. . Seal kit (RV10-20H)
11	041226	1	. Check valve, CV06
12	041222	1	. Check valve, PC10
13	011152	14	. Dowty seal, $\frac{1}{4}$ " BSP
14	020902	14	. Male stud, 6mm x $\frac{1}{4}$ " BSP
15	002190	2	. Banjo, $\frac{1}{4}$ " x 6mm
16	002191	1	. Test point 6mm
17	041223	1	. Plug, SAE 6
18	011242	2	. Plug, $\frac{3}{8}$ " BSP
19	011153	5	. Dowty seal, $\frac{3}{8}$ " BSP
20	002077	1	. Banjo, $\frac{3}{8}$ " BSP AB01-06
21	011166	1	. Adaptor, $\frac{3}{4}$ " BSP x $\frac{1}{2}$ " BSP
22	011160	1	. Adaptor, $\frac{1}{2}$ " BSP
23	011154	2	. Dowty seal, $\frac{1}{2}$ " BSP
NI	041228	AR	Cavity plug, 2-way, blocked (cartridge blanking plug)
24	025160	2	Male stud, 6mm x $\frac{3}{8}$ " BSP
25	020903	1	Male stud, 12mm x $\frac{3}{8}$ " BSP

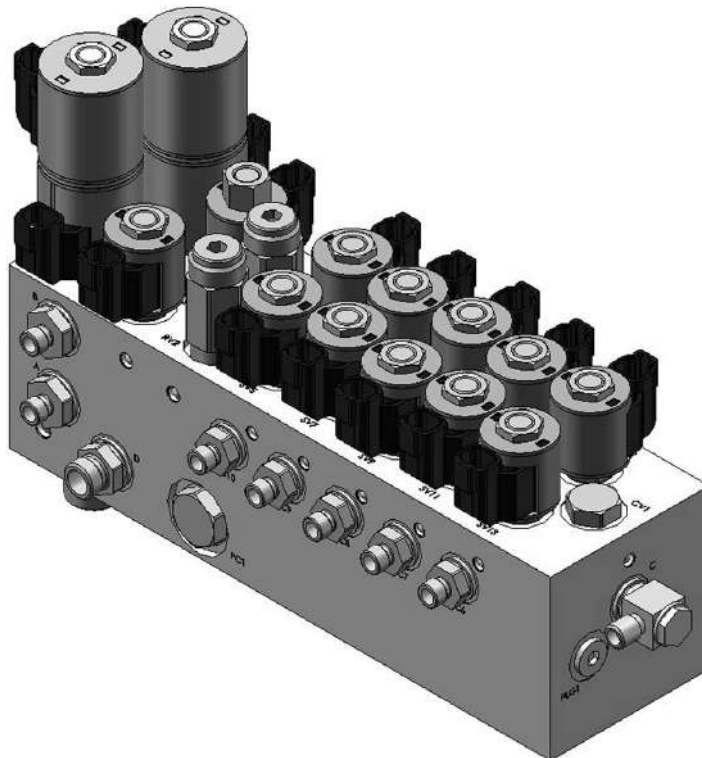

MAIN CONTROL VALVE BLOCK

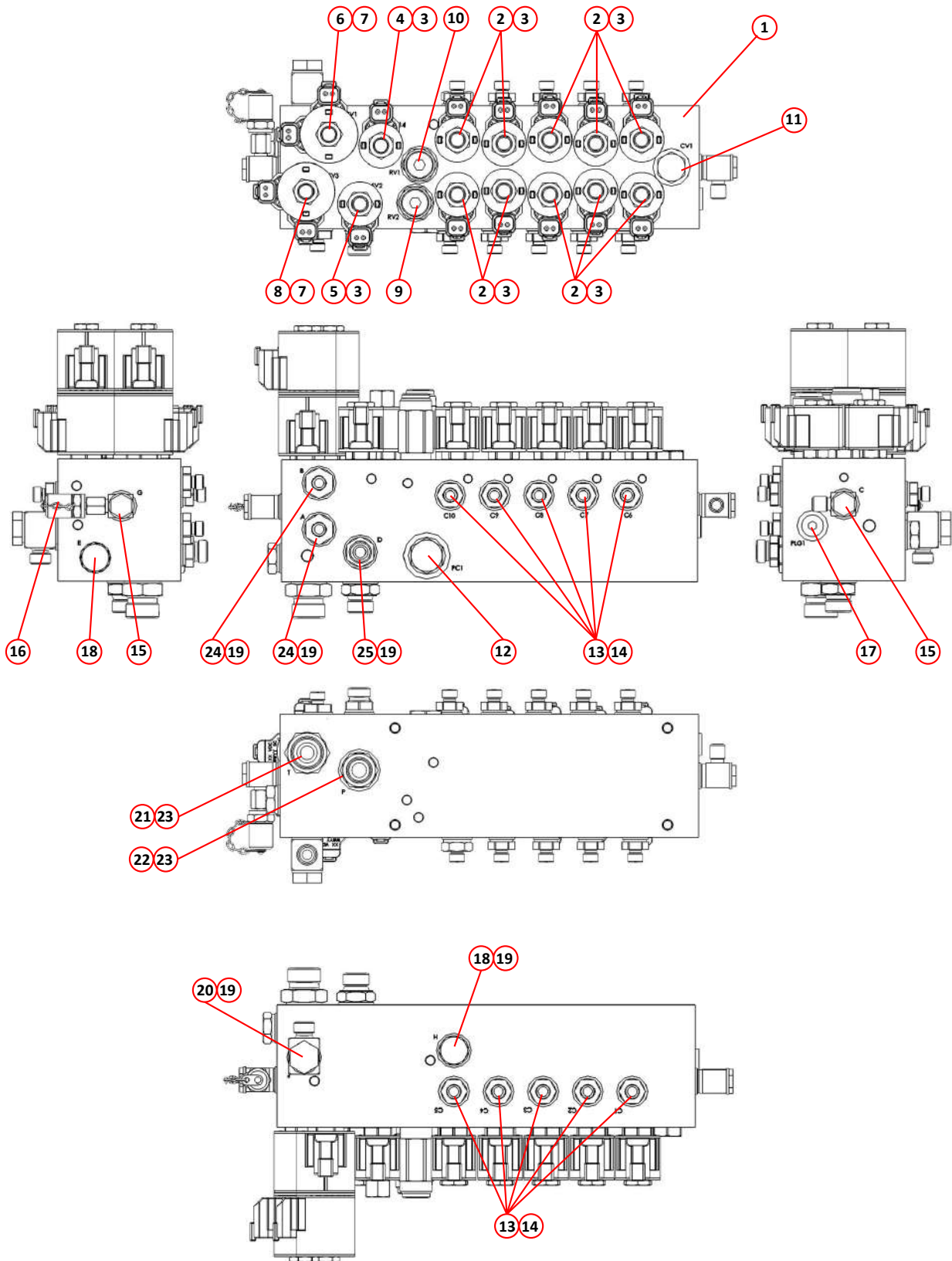

The above illustrations show completely populated blocks with all options fitted. When an option is not fitted the relevant cartridge and coil will be removed and the appropriate blanking plug will be inserted.

MAIN CONTROL VALVE BLOCK

<i>I</i>	<i>Item</i>	<i>Part Number</i>	<i>Quantity</i>	<i>Description</i>
				Brush Control Valve Block (Hydraforce)
	1	041236	1	Manifold, brush control valve block
	2	041233	4	. Cartridge (SV10-20)
NI		041256	4	. . Seal kit (SV10-20)
	3	041235	4	. . Coil, 12v/20.5 Watt. FL
	4	041219	4	. Cartridge (SV08-30)
NI		041246	10	. . Seal kit (SV08-30)
	5	041234	4	. . Coil, 12v/17.2 Watt. FL
	6	011242	1	. Plug, $\frac{3}{8}$ " BSP
	7	011153	10	. Dowty seal, $\frac{3}{8}$ " BSP
	8	011159	1	. Adaptor, $\frac{3}{4}$ " BSP
	9	020903	8	. Male stud, 12mm x $\frac{3}{4}$ " BSP

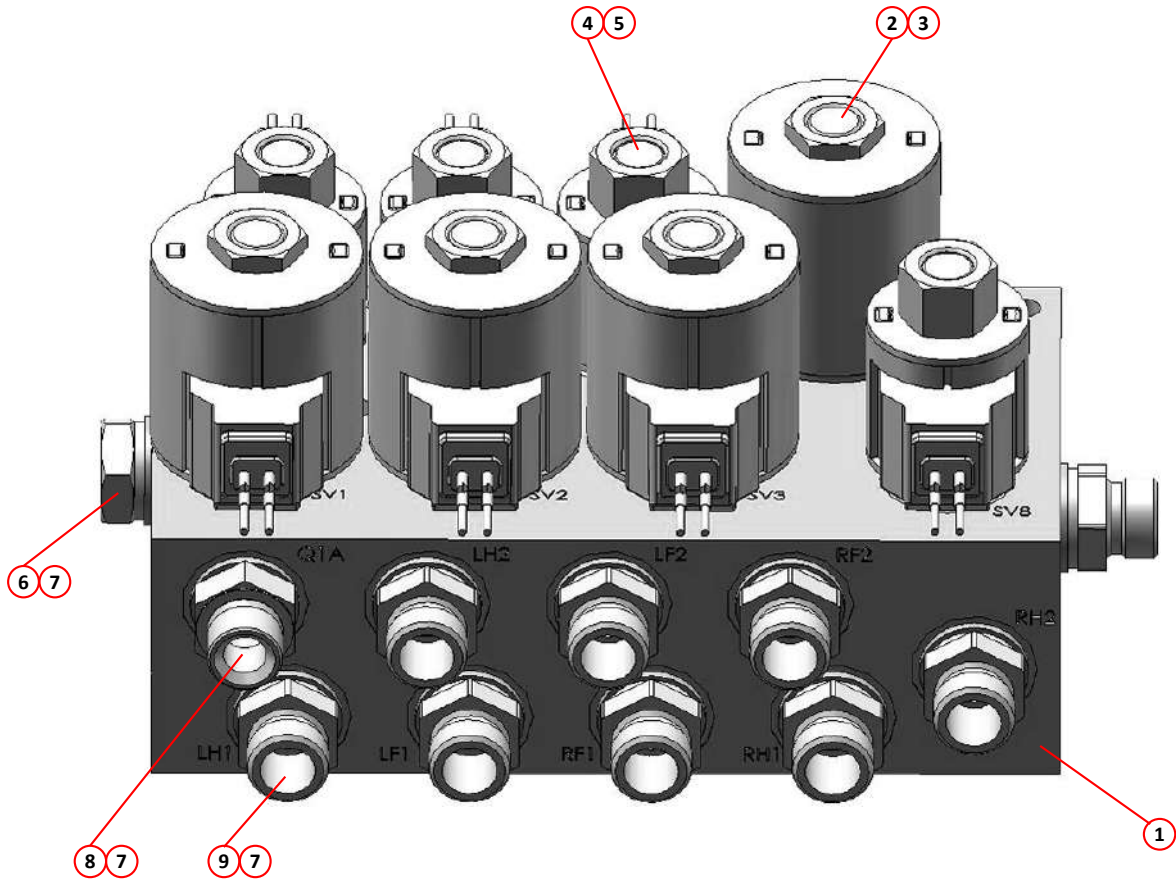

i The above illustration shows a completely populated block with all options fitted. When an option is not fitted the relevant cartridge and coil will be removed and the appropriate blanking plug will be inserted.

BRUSH CONTROL BLOCK

<i>Item</i>	<i>Part Number</i>	<i>Quantity</i>	<i>Description</i>
Main Control Valve Block (pre Hydraforce)			
1	025121	1	Valve block, main control Page 50
2	014663	10	. Solenoid (GS023300N)
3	014655	10	. . Coil, 14 Watt
4	025891	1	. Solenoid (GS041300N)
5	021753	1	. . Coil, 19 Watt
6	021744	1	. Solenoid (GS042100N)
7	021768	1	. . Coil, 28 Watt
8	020005	1	. Solenoid (GS045300N)
9	004208	2	. . Coil, 18 Watt
10	004186	1	. Solenoid (GS045200N)
11	004208	2	. . Coil, 18 Watt
12	033918	1	. Relief valve, brush lift (AO2B2HZ1-120N)
13	033917	1	. Relief valve, main (AO4B2PT32-170N)
NI	032823	2	. . Relief valve cap
NI	004205	1	Check valve (D04B2-21N)
NI	004295	1	. Pilot piston (PP045P)

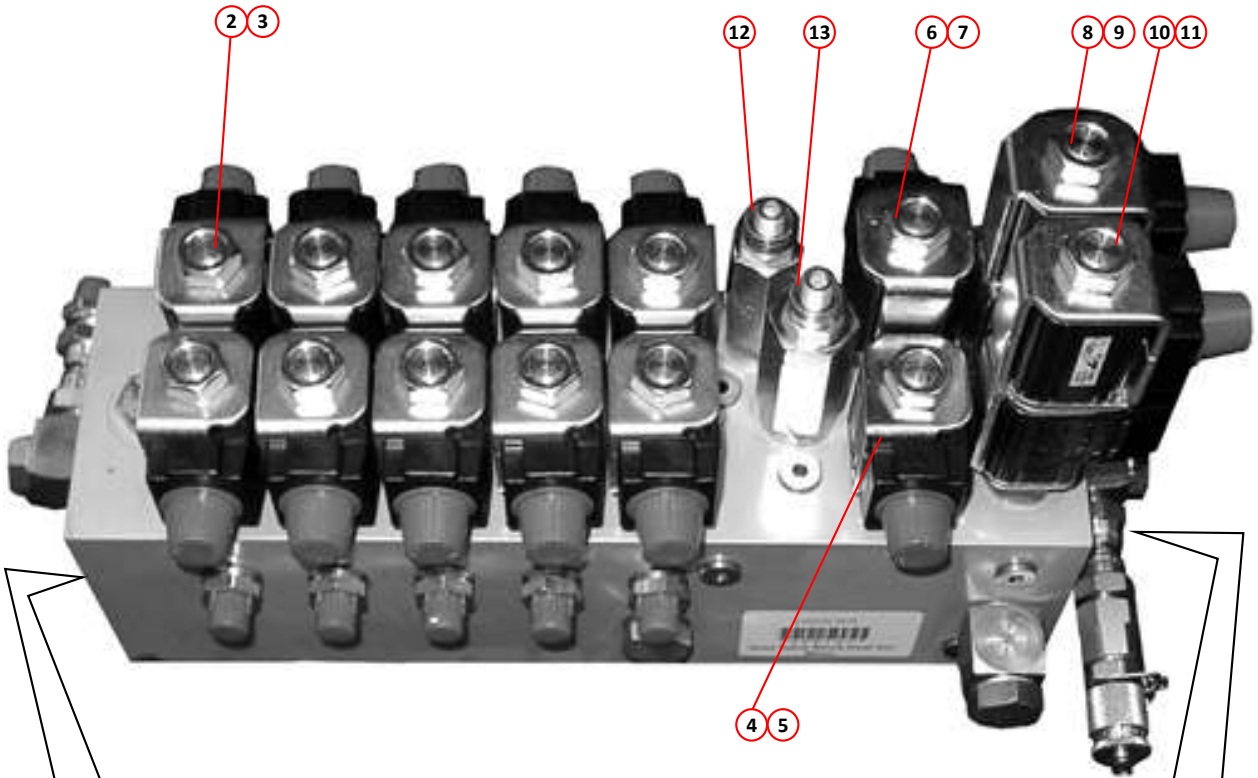

Dual Sweep Version Shown

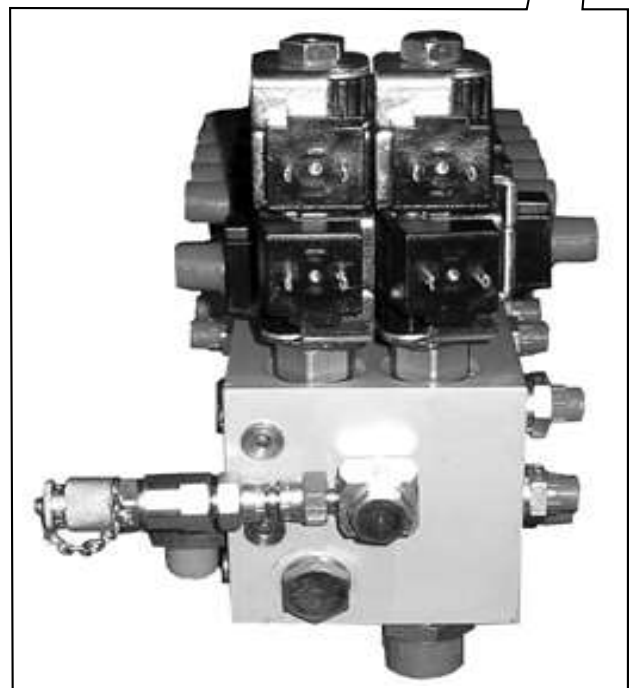
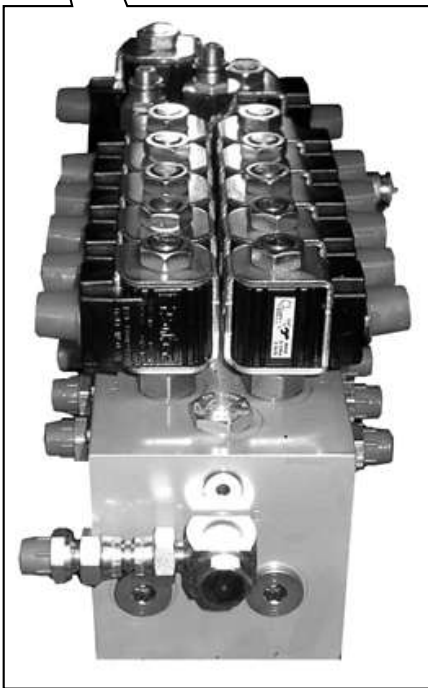

VALVE BLOCK - MAIN CONTROL

<i>Item</i>	<i>Part Number</i>	<i>Quantity</i>	<i>Description</i>
Brush Control Valve Block (pre Hydraforce)			
1	025119	1	Valve block - brush control, 4-spool, sterling BSK15696-B Page 50
2	014661	4	. Solenoid valve GS041200N
3	025890	4	. Solenoid valve GS040200N
4	021753	8	. Solenoid coil, CCP 19 Watt, 12 Volt
NI	011153	11	. Seal, Dowty $\frac{3}{8}$ "
NI	011159	3	. Adaptor, $\frac{3}{8}$ " BSP, M/M
NI	020903	7	. Stud, male, 12 x $\frac{3}{8}$ " BSP
NI	011242	1	. Plug, $\frac{3}{8}$ " BSP
NI	000141	2	. Screw, socket cap head, M6 x 80mm

<i>Item</i>	<i>Part Number</i>	<i>Quantity</i>	<i>Description</i>
Front Brush "Stop When Raised" Valve Components			
NI	025890	2	Valve - GS040200N
NI	014661	2	Valve - GS041200N]
NI	021753	4	Coil 12 Volt / 19 Watt
NI	028234	1	Wiring loom - front brush stop

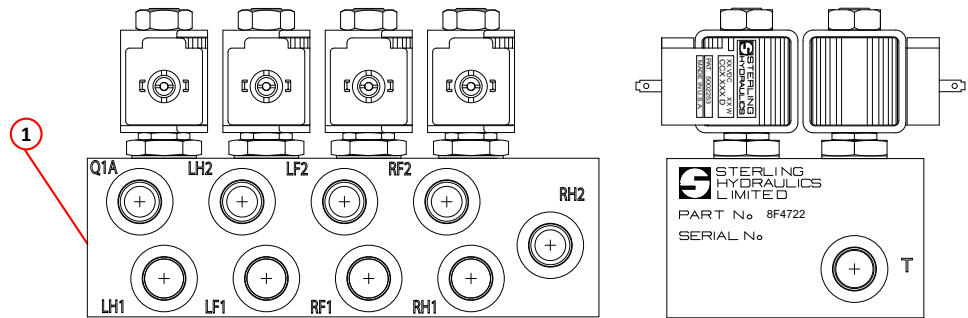
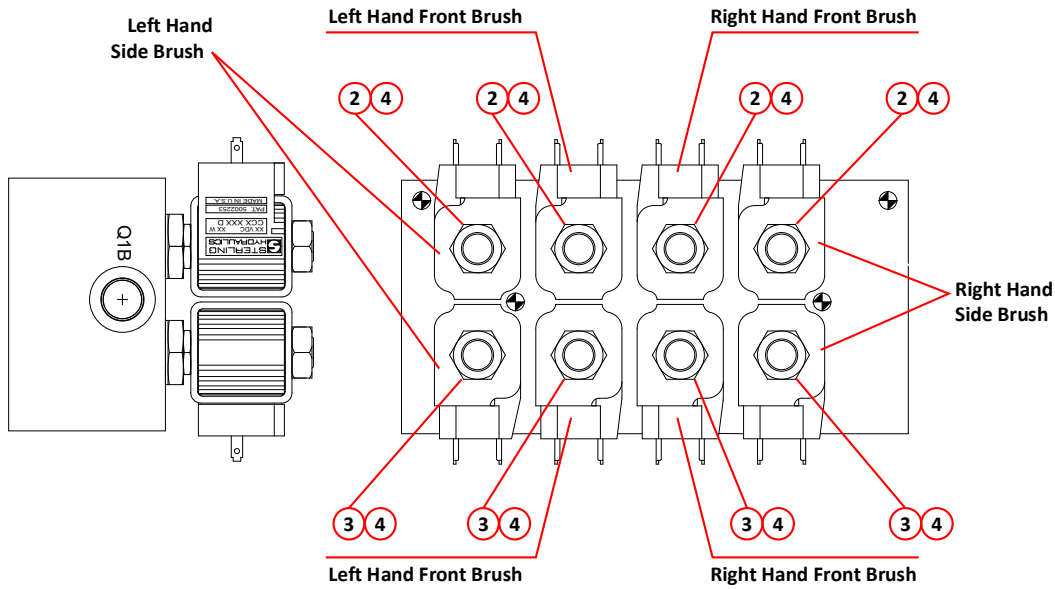

Left or right side brush valve positions will be blanked off according to build configuration unless sweeper is dual sweep.

For special build configurations not covered here, i.e. utilising either of the spare side brush positions, please refer to your Scarab Distributor or to the Scarab Parts Department, stating Sweeper Serial Number and details of any non-standard fittings.

VALVE BLOCK - BRUSH CONTROL

Item	Part Number	Quantity	Description
Transmission Pump Assembly			
1	024516	1	Pump, transmission
NI	024516(SE)	1	Pump, transmission, (service exchange unit)
2	011190	1	. Adaptor, $1\frac{1}{16}$ " UNF (SAE) x $\frac{3}{4}$ " BSP
3	002084	1	. . Hose tail, $\frac{3}{4}$ " BSP x 1" hose
4	011319	1	. Hose, rubber, $1\frac{1}{16}$ " BSP, straight end and 90°
5	011226	3	. Adaptor, M/M, $\frac{7}{8}$ " UNF (SAE) x $\frac{1}{2}$ " BSP
6	011167	1	. . Elbow, swivel, $\frac{1}{2}$ " BSP x $\frac{5}{8}$ " hose
7	013887	1	. Valve, relief, $\frac{1}{4}$ " BSP
8	011152	4	. . Seal, Dowty, $\frac{1}{4}$ " BSP
9	011158	3	. . Adaptor, M/M, $\frac{1}{4}$ " BSP
10	011169	1	. . Elbow, swivel, F/F, $\frac{1}{4}$ " BSP
11	011264	2	. . Adaptor, M/M, $\frac{9}{16}$ " UNF (SAE) x $\frac{1}{4}$ " BSP
12	032884	1	. Drive hub
13	026655	2	. Valve, Reverse/Forward drive
14	026775	4	. . Cap, plastic, cap head cover
15	002112	1	. Adaptor, swivel, M/F, $\frac{1}{4}$ " BSP
16	014655	1	. Coil, 12 Volt (pre Hydraforce)
17	013888	1	. Valve, Reverse, $\frac{1}{4}$ " BSP (pre Hydraforce)
NI	025728*	1	. Seal, O-ring, adaptor plate with (SLOTTED FIXING HOLES)
NI	036829*	1	. Seal, O-ring, adaptor plate with (ROUND FIXING HOLES)
18	041560	1	Reverse valve, with block, solenoid and coil (Hydraforce)
19	041640	1	Valve block, $\frac{3}{8}$ " BSP (Hydraforce)
20	041225	1	Coil, 12V 17.2 Watts-ELZ (for Hydraforce)
21	041643	1	Solenoid valve, SF08-21 (for Hydraforce)
22	011153	2	Dowty Seal, $\frac{3}{8}$ " BSP
23	011199	1	Adaptor, $\frac{3}{8}$ " BSP x $\frac{1}{4}$ " BSP
24	002215	1	Adaptor, swivel, M/F, $\frac{3}{8}$ " BSP x $\frac{1}{4}$ " BSP
25	025040	1	Restrictor $\frac{1}{32}$, $\frac{9}{16}$ x $\frac{1}{4}$ " BSP (with o ring)
26	041559	1	Relief valve, with block and valve (Hydraforce)
27	041640	1	Valve block, $\frac{3}{8}$ " BSP (Hydraforce)
28	041641	1	Relief valve (Hydraforce)
29	011153	2	Dowty Seal, $\frac{3}{8}$ " BSP
30	011199	2	Adaptor, $\frac{3}{8}$ " BSP x $\frac{1}{4}$ " BSP
31	011169	1	Elbow, swivel, F/F, $\frac{1}{4}$ " BSP
32	011264	2	Adaptor, M/M, $\frac{9}{16}$ " UNF (SAE) x $\frac{1}{4}$ " BSP (with o ring)

Notes:-

* When ordering check the flange plate fixing hoses. If in doubt contact Scarab Parts Department.

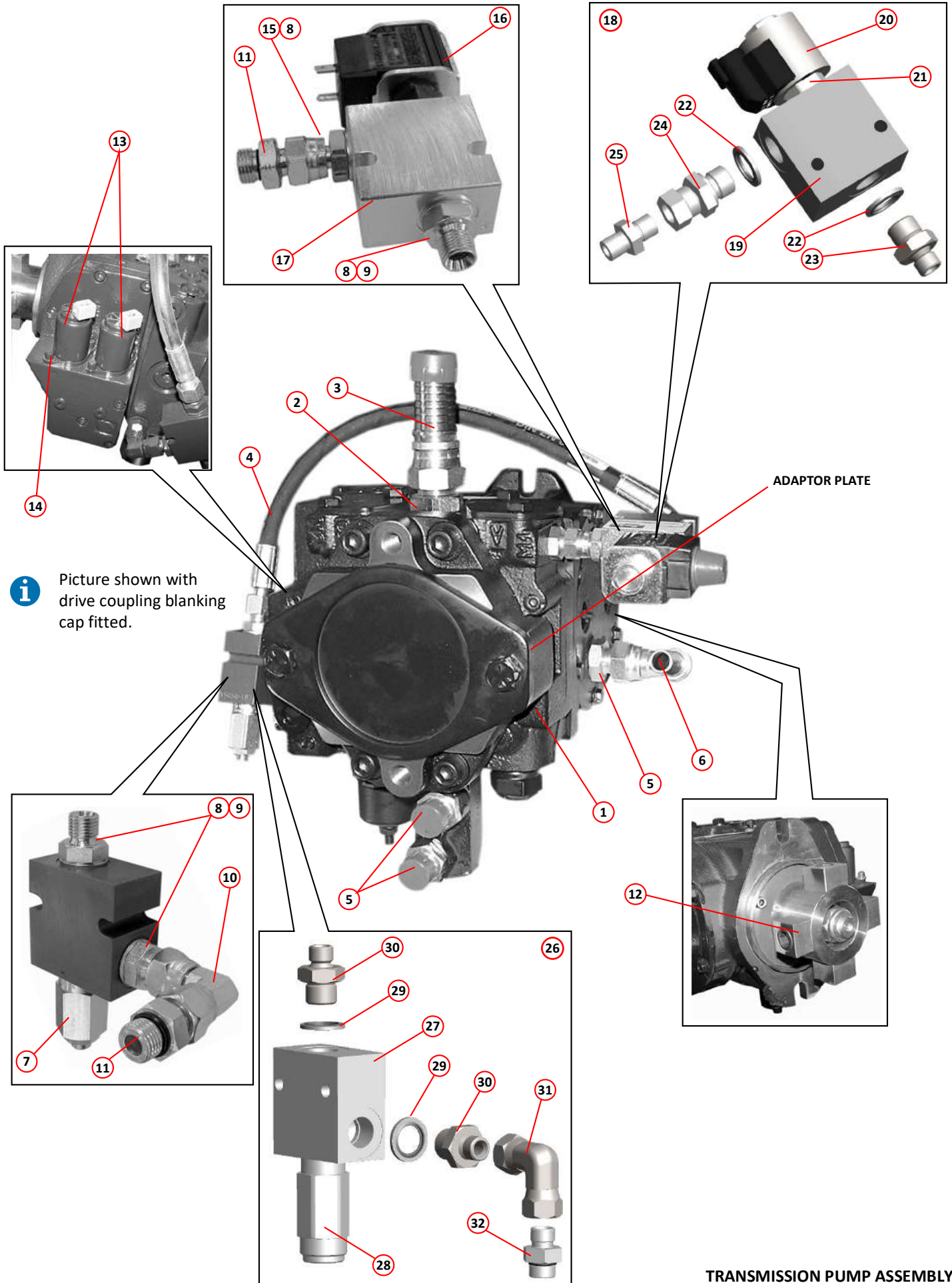

i Picture shown with drive coupling blanking cap fitted.

TRANSMISSION PUMP ASSEMBLY

Item	Part Number	Quantity	Description
Suction Fan Pump Assembly			
1	038977	1	Suction fan pump, LS45 - SAUER (remote mounted valve)
2	040162	1	Suction fan pump, LS45 - SAUER (direct mounted valve)
3	039392	1	. Valve, DFR
4	011227	1	. . Adaptor, M/M, $\frac{7}{16}$ " UNF (SAE) x $\frac{1}{4}$ " BSP
NI	011171	1	. . Elbow, swivel, M/F, $\frac{1}{4}$ " BSP
5	001105	1	. . . Hose, $\frac{1}{4}$ " BSP x 400mm, straight and 90° connectors
6	002192*	1	. . Test point, $\frac{7}{16}$ " UNF (SAE)
7	002200	1	. Adaptor, M/M, $\frac{1}{8}$ " x 12 to $\frac{1}{2}$ " BSP, complete with O-ring
NI	002086	1	. . Elbow, swivel, $\frac{1}{2}$ " BSPF x 1" hose
8	011226	1	. Adaptor, M/M, $\frac{7}{8}$ " UNF (SAE) x $\frac{1}{2}$ " BSP, complete with O-ring
9	002198	1	. Adaptor, M/M, $\frac{5}{16}$ " x 12 to $\frac{3}{4}$ " BSP, complete with O-ring
10	011213	1	. . Elbow, swivel, F/F, $\frac{3}{4}$ " BSP
11	011193	1	. . . Adaptor, reducer, M/M, 1" BSP x $\frac{3}{4}$ " BSP
12	011156	1 Seal, Dowty, 1" BSP
13	026264	1 Flange, 1 SAE, 1" BSP, 3000 PSI, threaded
14	013689	1	. Valve, suction fan
	011037	4	. . Bolt, high tensile, M10 x 65mm (remote mounted valve)
	011107	4	. . Screw, socket cap head, $\frac{3}{8}$ " UNC x 2 $\frac{1}{2}$ " long (direct mounted valve)
15	011231	1	. Elbow, flanged, $\frac{1}{2}$ " (SAE) x 1" Hose (direct mounted valve)
16	011230	1	. . Flange, split, $\frac{1}{2}$ " (SAE) (direct mounted valve)
	011108	4	. . . Screw, socket cap head, $\frac{1}{2}$ " UNC x 1 $\frac{1}{2}$ " long (direct mounted valve)
17	014655	1	. . Coil, 12 Volt, 14W, CCS012D
18	014654	1	. . . Solenoid, GS020100N
19	011242	1	. . Plug, $\frac{3}{8}$ " BSP
20	011153	1	. . . Seal, Dowty, $\frac{3}{8}$ " BSP
21	011163	1	. . Adaptor, M/M, $\frac{1}{8}$ " BSP x $\frac{1}{4}$ " BSP
22	011151	1	. . . Seal, Dowty, $\frac{1}{8}$ " BSP
23	001101	1 Hose, $\frac{1}{4}$ " BSP x 1125mm, straight and 90° connectors
24	011161	1	. . Adaptor, M/M, $\frac{3}{4}$ " BSP
25	011155	1	. . . Seal, Dowty, $\frac{3}{4}$ " BSP
26	014157	1 Hose, $\frac{5}{8}$ " x 2230mm with $\frac{3}{4}$ " BSP straight connectors
27	011199	1	. . Adaptor, M/M, $\frac{3}{8}$ " BSP x $\frac{1}{4}$ " BSP
28	011153	1	. . . Seal, Dowty, $\frac{3}{8}$ " BSP
29	011244	1	. . Plug, $\frac{3}{4}$ " BSP
30	011155	1	. . . Seal, Dowty, $\frac{3}{4}$ " BSP

Item	Part Number	Quantity	Description
Suction Fan Valve Block Assembly (Hydraforce)			
	041562	1	Valve block, suction fan control, with coil, solenoid and orifice plug
31	041628	1	Manifold
32	042481	1	Orifice plug 4.80mm
33	041626	1	'O' Ring
34	042482	1	Solenoid valve, SV08-22 HF
35	041225	1	Coil 12v/17.2 Watts
36	041237	1	Coil nut
37	011155	1	Seal, Dowty, $\frac{3}{4}$ " BSP
38	011161	1	Adaptor, M/M, $\frac{3}{4}$ " BSP
39	011151	1	Seal, Dowty, $\frac{1}{8}$ " BSP
40	011163	1	Adaptor, M/M, $\frac{1}{8}$ " BSP x $\frac{1}{4}$ " BSP
41	011107	4	Socket cap head screw, $\frac{3}{8}$ " UNC x 2 $\frac{1}{2}$ " long
42	011153	1	Seal, Dowty, $\frac{3}{8}$ " BSP
43	011242	1	Plug, $\frac{3}{8}$ " BSP
44	011155	1	Seal, Dowty, $\frac{3}{4}$ " BSP
45	011244	1	Plug, $\frac{3}{4}$ " BSP
46	011151	1	Seal, Dowty, $\frac{1}{8}$ " BSP
47	011163	1	Adaptor, M/M, $\frac{1}{8}$ " BSP x $\frac{1}{4}$ " BSP
NI	041226	1	Seal kit

Notes:-

* Test point could be in a different port on the DFR valve.

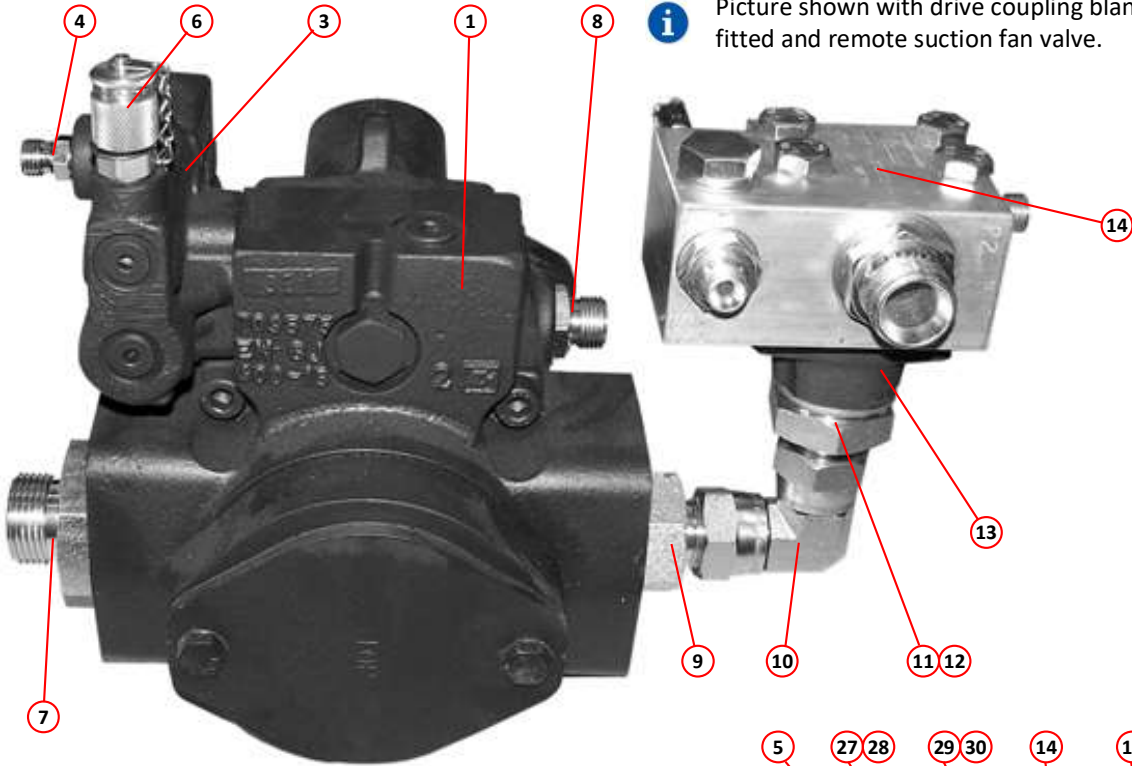

i Picture shown with drive coupling blanking cap fitted and remote suction fan valve.

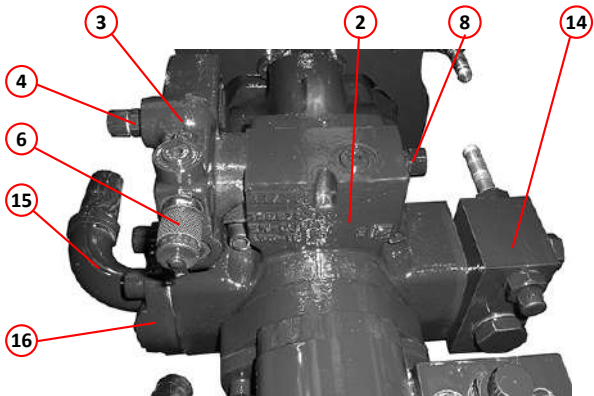

i Picture shows suction fan pump with direct mounted suction fan valve.

SUCTION FAN PUMP ASSEMBLY

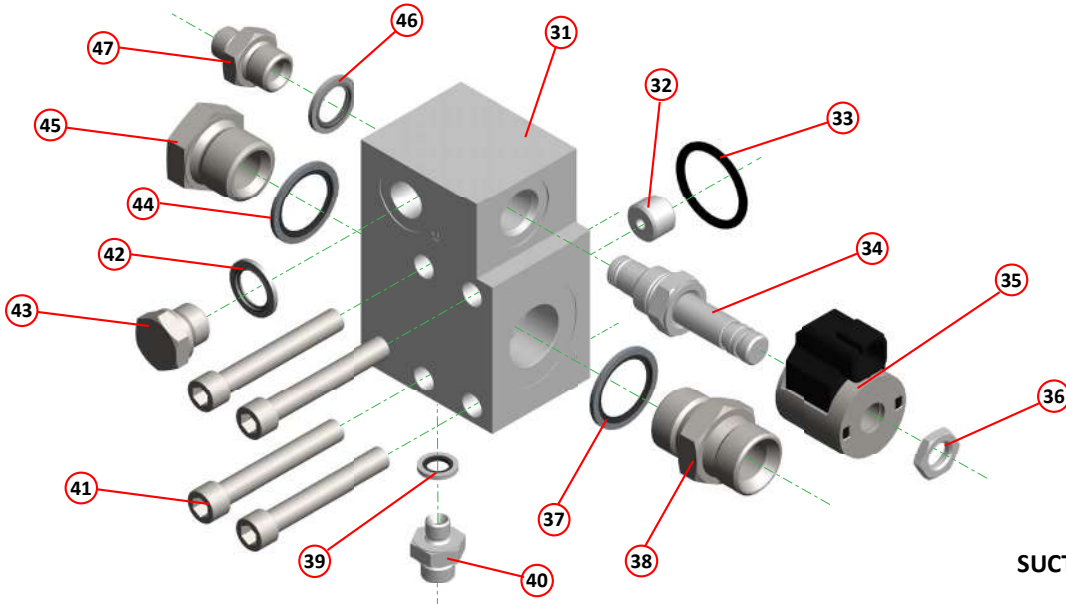
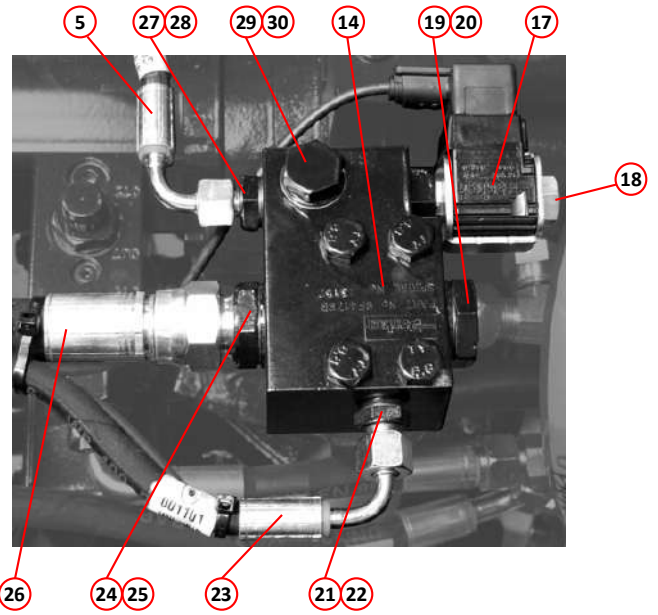

SUCTION FAN VALVE BLOCK (HYDRAFORCE)

Item	Part Number	Quantity	Description
Suction Fan Motor Assembly			
1	024641	1	Fan MotorPage 130, 136
NI	000343	2	. Bolt, socket cap, M14 x 50mm
NI	011127	2	. . Nut, M14, Nyloc
2	011052	1	. Fan mounting bolt, M12 x 30mm
3	024791	1	. . Cap washer VOAC motor
4	041564	1	. Anti-cavitation valve block (Hydraforce)
4	035967	1	. Anti-cavitation valve block (non-Hydraforce)
5	013523	2	. . O Ring, 25mm ID 3.5mm dia section
6	000048	8	. . Setscrew, socket cap head, M10 x 80mm
7	011095	8	. . . Spring washer, M10
8	011161	2	. . Adaptor, M/M, $\frac{3}{4}$ " BSP
9	011155	2	. . . Seal, Dowty, $\frac{3}{4}$ " BSP
10	011248	1	. . Adaptor, M/M, M18 x $\frac{3}{8}$ " BSP
11	011247	1	. . . Seal, Dowty, M18 BSP
12	010921	1	. . . Hose tail, $\frac{3}{8}$ " BSP nut x $\frac{3}{8}$ " hose

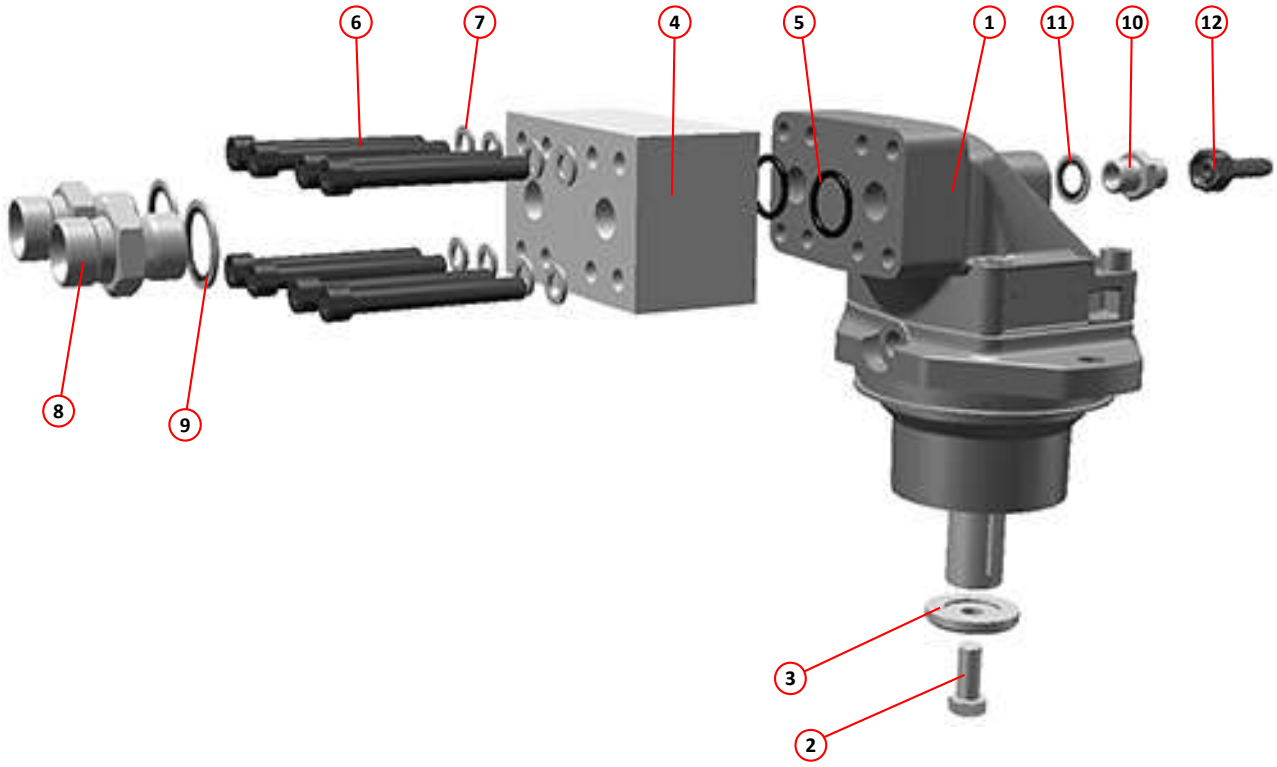

SUCTION FAN MOTOR ASSEMBLY

<i>Item</i>	<i>Part Number</i>	<i>Quantity</i>	<i>Description</i>
Gear Pump Assembly			
1	024592	1	Gear pump (double)
2	027056	1	. Elbow, suction
	013518	1	. . Seal, O-ring
	011011	4	. . Setscrew, M8 x 25mm
	011093	4	. . Washer, spring, M8
3	024537	1	. Valve, flow control
NI	024486	1	. Seal, O-ring, kit
	000227	4	. . Bolt, M8 x 110mm
	011093	4	. . Washer, spring, M8
	011092	4	. . Washer, M8
4	011160	1	. Adaptor, M/M, $\frac{1}{2}$ " BSP
5	011154	2	. . Seal, Dowty, $\frac{1}{2}$ "
6	011242	1	. Plug, $\frac{3}{8}$ " BSP
7	011153	2	. . Seal, Dowty, $\frac{3}{8}$ " BSP
8	011167	1	. Adaptor, M/M, $\frac{1}{2}$ " x $\frac{3}{8}$ " BSP
9	011172	1	. Elbow, swivel, M/F, $\frac{3}{8}$ " BSP

<i>Item</i>	<i>Part Number</i>	<i>Quantity</i>	<i>Description</i>
Complete Transmission Assembly			
1	032569	1	Bracket, transmission support, LH
2	035670	1	Bracket, transmission support, RH
3	013409	4	Mounting, rubber
	011075	4	. Nut, M10, Nyloc
	011074	8	. Washer, M10
4	037142	1	Cross member

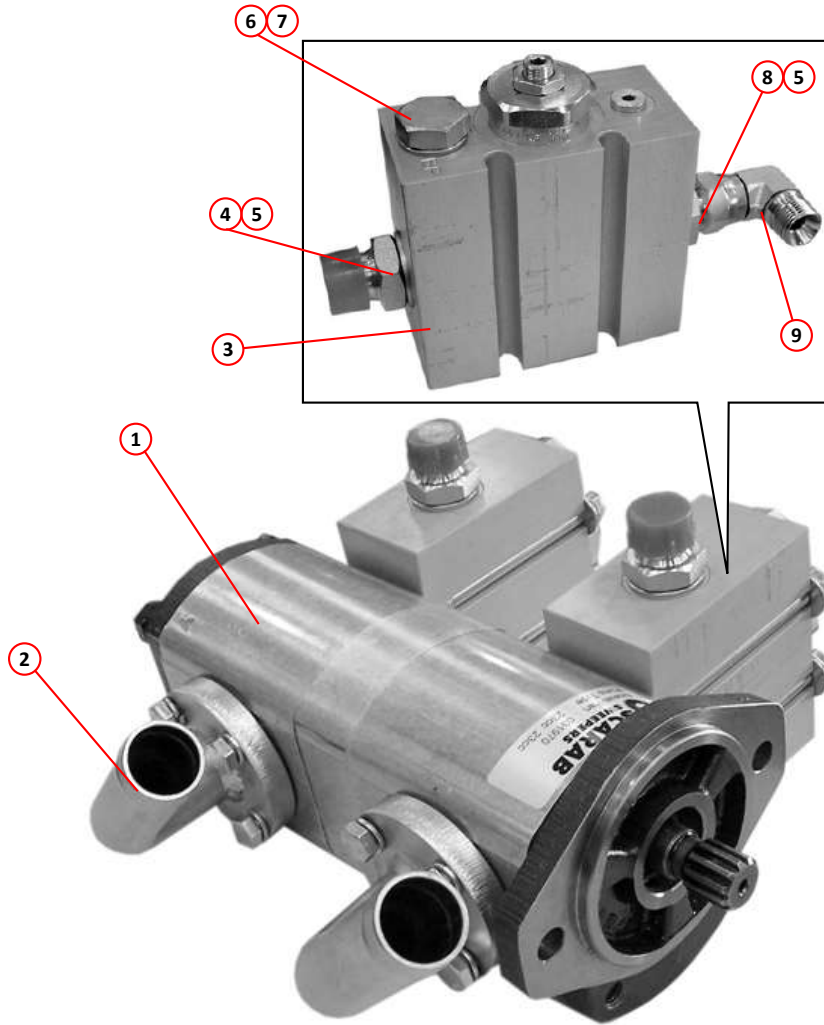

GEAR PUMP ASSEMBLY

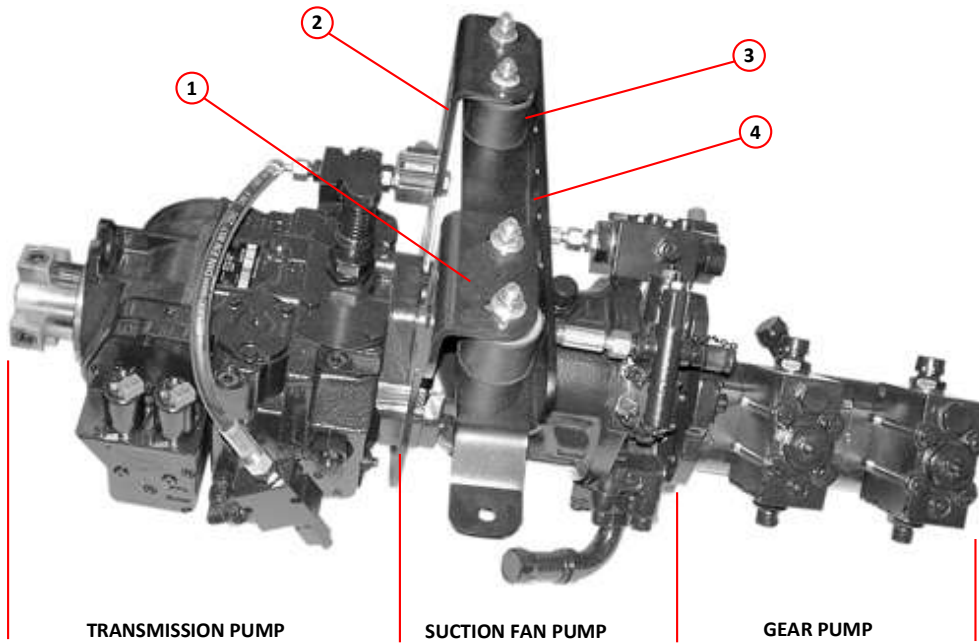

TRANSMISSION PUMP

SUCTION FAN PUMP

GEAR PUMP

COMPLETE TRANSMISSION ASSEMBLY

Item	Part Number	Quantity	Description
Radiator/Cooler Assembly			
1	037143	1	Radiator/Cooler (complete), less motor Page 16,
NI	046275	1	Fan and Hub Kit only
NI	037703	1	. Partition
2	025372	1	. Hydraulic motor 14cc
3	011167	1	. . Adaptor, M/F, $\frac{1}{2}$ " x $\frac{3}{8}$ " BSP
4	011154	2	. . Seal, Dowty, $\frac{1}{2}$ " BSP
5	011233	1	. . Tee, swivel, M/M/F, $\frac{3}{8}$ " BSP
6	001252	1	. . Hose, rubber, $\frac{3}{8}$ " BSP x 2540mm, straight and 90° ends
7	010910	1	. Elbow, galvanised, M/F, $\frac{1}{4}$ " BSP
8	003010	1	. . Hose tail, $\frac{1}{4}$ " BSPT x $\frac{3}{8}$ " bore pipe
9	011160	1	. Adaptor, M/M, $\frac{1}{2}$ " BSP
10	002110	1	. . Tee, swivel, M/M/F, $\frac{1}{2}$ " x $\frac{3}{8}$ " x $\frac{1}{2}$ " BSP
11	011234	1	. . Elbow, hose tail swivel, $\frac{1}{2}$ " BSP x $\frac{5}{8}$ " bore pipe
12	001184	1	. Pipe, rubber, $\frac{5}{8}$ " bore x 1720mm
13	010517	2	. . Clamp, worm drive, size 18-25mm
14	001204	1	. . Pipe, rubber, $\frac{3}{8}$ " bore x 800mm
15	010516	2	. . Clamp, worm drive, 11-16mm
16	011308	1	. Hose, rubber, $\frac{3}{8}$ " BSP x 500mm, straight ends
17	001220	1	. Hose, rubber, $\frac{3}{8}$ " BSP x 410mm, straight and 90° ends
18	037227	1	. Valve, flow control, cooler
	011068	2	. . setscrew, M6 x 35mm
	011091	2	. . Washer, spring, M6
	011090	2	. . Washer, M6
NI	037425	1	. . Bracket, flow control valve
	011001	2	. . . Setscrew, M6 x 16mm
	011091	2	. . . Washer, M6
19	001253	1	. Hose, rubber, $\frac{3}{8}$ " BSP x 3250mm, straight and 90° ends
20	002084	1	. Hose tail, $\frac{3}{4}$ " BSP x 1" hose
21	010959	1	. Pipe, rubber, 1" x 350mm
22	014828	2	. . Clamp, worm drive, 25-40mm, high-torque
23	002154	1	. Tee, M/M/M, $\frac{3}{4}$ " x $\frac{3}{4}$ " x $\frac{3}{8}$ " BSP
24	001220	1	. Hose, rubber, $\frac{3}{8}$ " BSP x 410mm, straight and 90° ends
25	001219	1	. Hose, rubber, $\frac{3}{4}$ " BSP x 861mm, straight ends
26	001238	1	. Hose, rubber, $\frac{5}{8}$ " bore x 420mm, $\frac{3}{4}$ " BSP, straight and 90° ends

Item	Part Number	Quantity	Description
Manifold Assembly			
27	025148	1	Manifold, oil return
28	021575	1	. Pipe, rubber, 2" bore x 230mm
29	028778	4	. . Clamp, worm drive, 40-70mm, high-torque
	011001	3	. . . Setscrew, M6 x 16mm
	011071	3	. . . Nut, M6, Nyloc
30	026868	1	. . Bracket, manifold
	011001	2	. . . Setscrew, M6 x 16mm
	011071	2	. . . Nut, M6, Nyloc
31	027742	1	Manifold, oil tank feed
32	022442	1	. Pipe, rubber, 2" bore x 280mm
	010959	1	. Pipe, rubber, 1" x 350mm
	011001	3	. . . Setscrew, M6 x 16mm
	011071	3	. . . Nut, M6, Nyloc

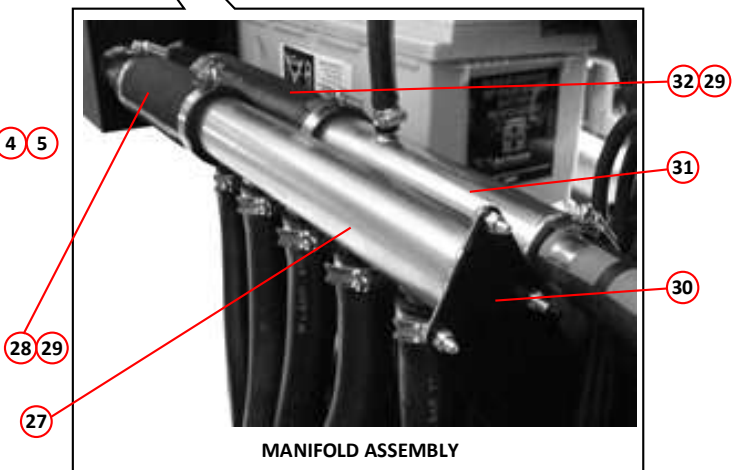
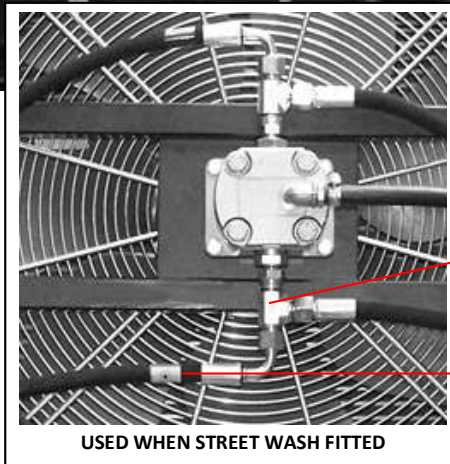
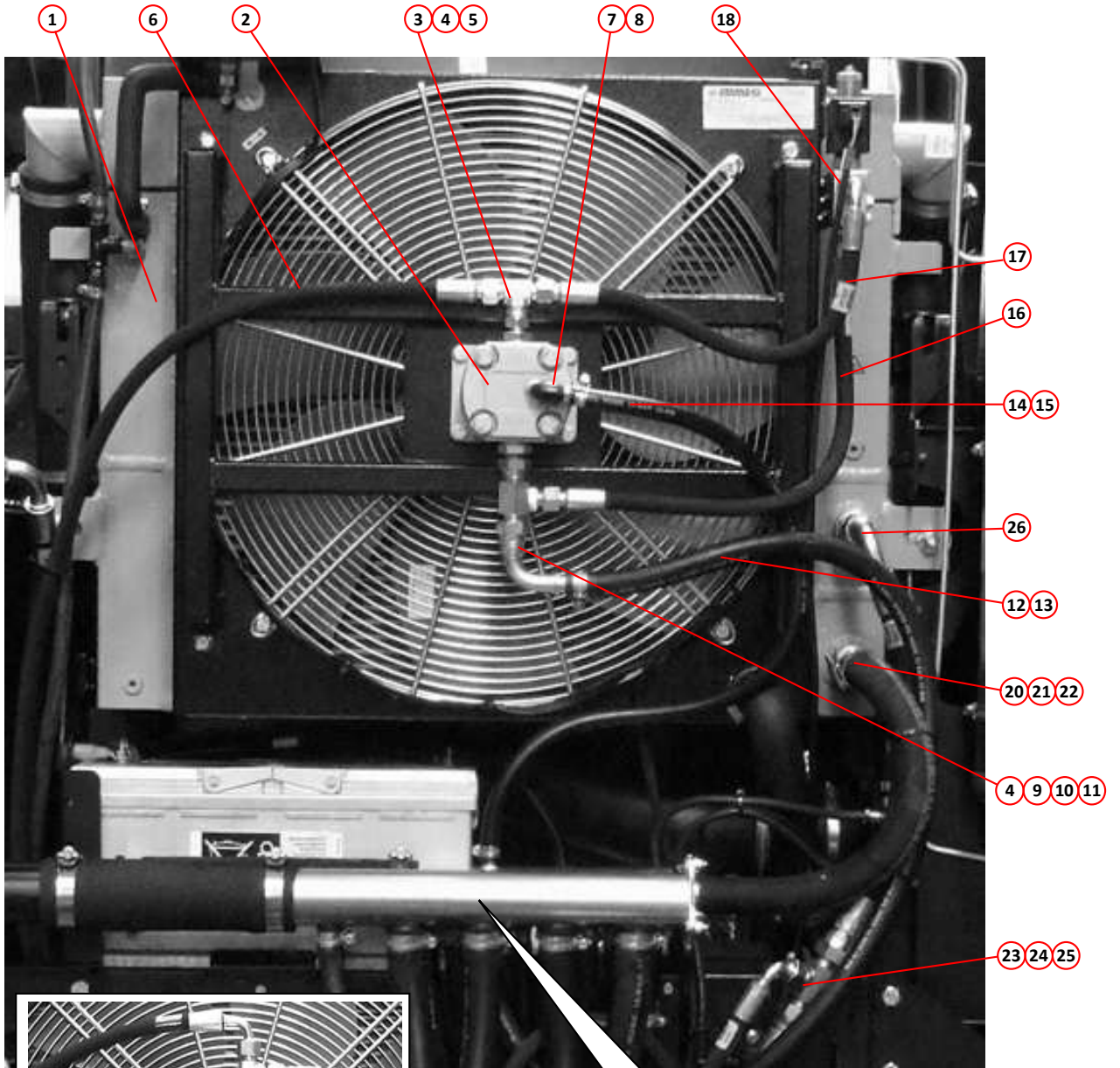

RADIATOR/COOLER ASSEMBLY

Item	Part Number	Quantity	Description
Oil Tank Assembly			
1	038521	1	Oil tank
2	023155	1	. Gauge, fluid level
NI	036794	2	. . Washer, rubber sealing
3	038529	1	. Gasket, oil tank
4	038522	1	. Lid, oil tank
NI	038523	1	. Lid, oil tank. (Used when Teal wash fitted)
	000252	24	. . Setscrew, M6 X 20mm, stainless steel
	000339	24	. . Washer, shake proof, M6
5	020689	1	. Adaptor, M/F, $\frac{1}{4}$ " x $\frac{1}{4}$ " BSP
6	011156	1	. . Seal, Dowty 1 BSP
7	020688	1	. Filter, breather
8	011152	1	. . Seal, Dowty, $\frac{1}{4}$ " BSP
9	038538	1	. Filter, return (complete)
NI	011972	1	. . Filter, return, element only
10	011161	1	. Adaptor, $\frac{3}{4}$ " BSP, M/M
11	011174	1	. Elbow, swivel, M/F, $\frac{3}{4}$ " BSP
12	020687	1	. Filter, Suction element
13	010305	1	. Magnet (Inside Tank)
14	003006	1	. Adaptor, galvanised, M/F, $\frac{3}{4}$ " x $\frac{1}{4}$ " BSP
15	010944	1	. Adaptor, M/M, $\frac{1}{4}$ " BSP, galvanised
16	011743	1	. Valve, ball, $\frac{1}{4}$ " BSP
17	010910	1	. Elbow, M/F, $\frac{1}{4}$ " BSP, galvanised
18	011241	1	. Plug $\frac{1}{4}$ " BSP
NI	028760	1	Label - oil tank
NI	034549	1	Label, hydraulic oil level

Item	Part Number	Quantity	Description
Suction Filter Assembly (Chassis Mounted)			
	021730	1	Filter, suction (complete)
1	021038	1	. Filter, suction element
2	021731	1	. Filter, suction head
	011022	4	. . Setscrew, hex head, $\frac{3}{8}$ " UNC x $\frac{3}{4}$ "
	011406	4	. . Washer, spring, $\frac{3}{8}$ "
NI	040215	1	. Bracket, support suction filter
3	001075	1	. Hose, rubber, $\frac{1}{2}$ " x 500mm, straight and 90° ends
4	001076	1	. Hose, rubber, $\frac{1}{2}$ " x 600mm, straight and 90° ends
5	011265	2	. . Adaptor, $1\frac{1}{16}$ " UNF (SAE) x $\frac{3}{4}$ " long, complete with O-ring

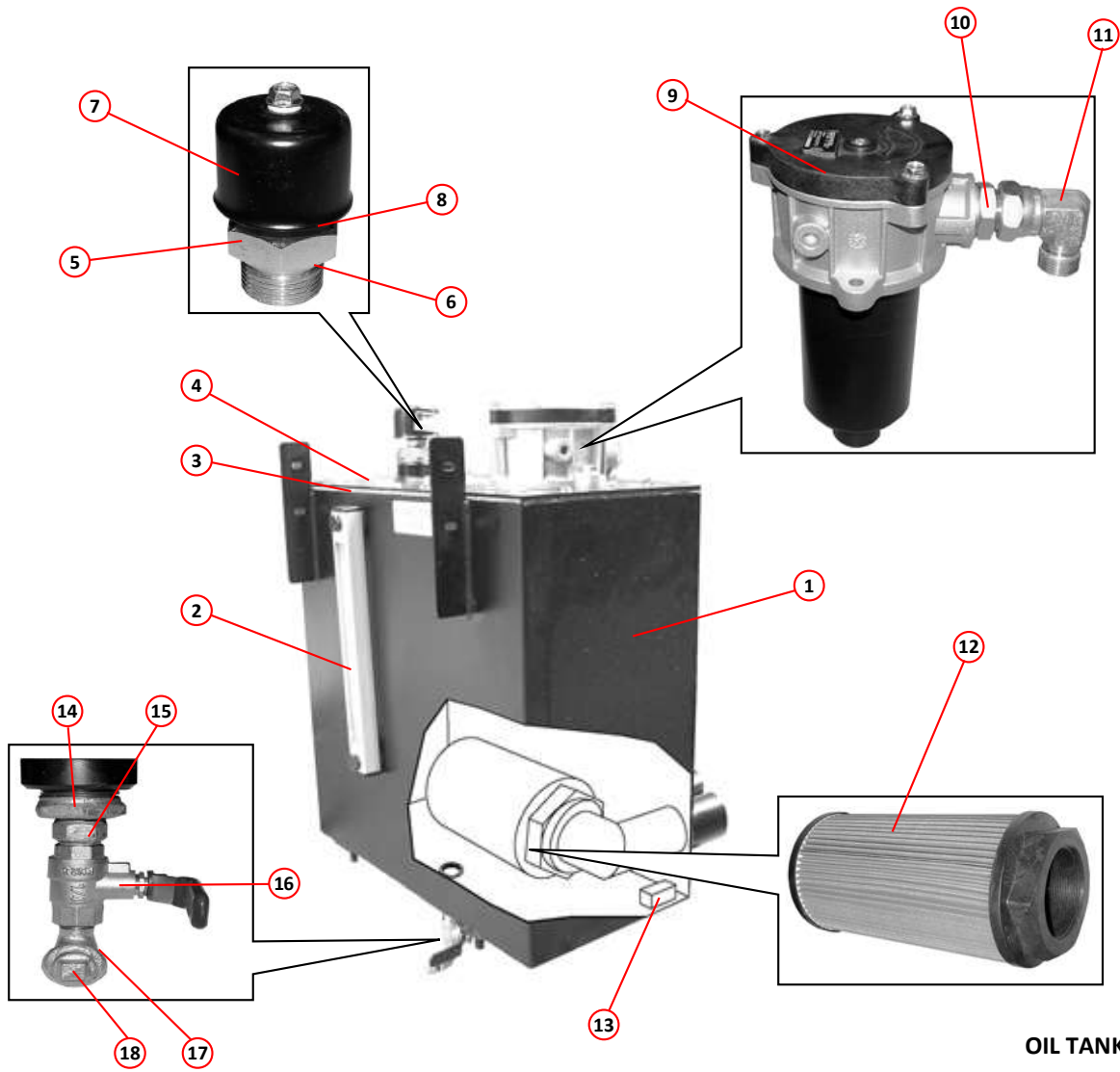

OIL TANK ASSEMBLY

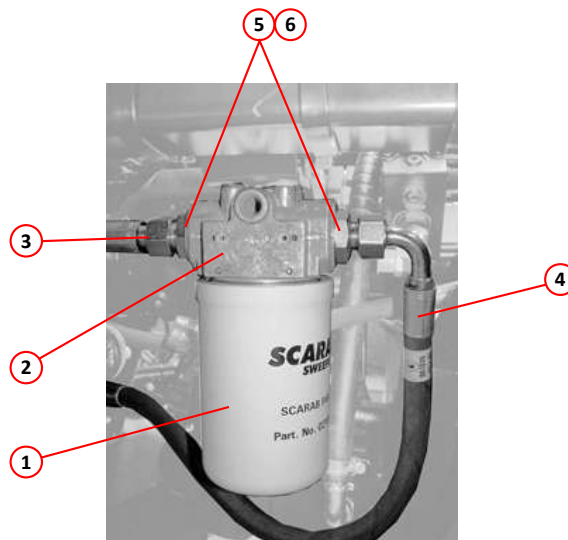

SUCTION FILTER ASSEMBLY

Item	Part Number	Quantity	Description
Power Steering Regulator Valve			
1	025599	1	Valve, regulator Page 160
2	011167	2	. Adaptor, M/M, $\frac{1}{2}$ " x $\frac{3}{8}$ " BSP
3	011160	1	. Adaptor, M/M, $\frac{1}{2}$ " BSP
4	011154	3	. . Seal, Dowty, $\frac{1}{2}$ " BSP
	000009	2	. Bolt, M8 x 55mm
	011092	2	. Washer, M8
	011073	2	. Nut, M8, Nyloc

Item	Part Number	Quantity	Description
Power Steering Regulator Valve (Hydraforce)			
	041561	1	Valve regulator, power steering pump complete (items 1,2 & 3)
1	041618	1	Manifold
2	041619	1	Relief valve, RV10-20
3	041620	1	Flow regulator valve, FR10-39
4	011167	2	Adaptor, M/M, $\frac{1}{2}$ " x $\frac{3}{8}$ " BSP
5	011160	1	Adaptor, M/M, $\frac{1}{2}$ " BSP
6	011154	3	Seal, Dowty, $\frac{1}{2}$ " BSP
7	000009	2	Bolt, M8 x 55mm
8	011092	2	Washer, M8
9	011073	2	Nut, M8, Nyloc
NI	041621	1	Seal kit, relief valve
NI	041622	1	Seal kit, flow regulator

Item	Part Number	Quantity	Description
High Pressure Water Pump Drive Motor			
1	021315	1	Motor, hydraulic, 15cc, 1MR015 Page 160
2	011158	1	. Adaptor, M/M, $\frac{1}{4}$ " BSP
3	011150	1	. Seal, Dowty, $\frac{1}{4}$ " BSP
4	011167	2	. Adaptor, M/M, $\frac{1}{2}$ " x $\frac{3}{8}$ " BSP
5	011154	2	. Seal, Dowty, $\frac{1}{2}$ " BSP

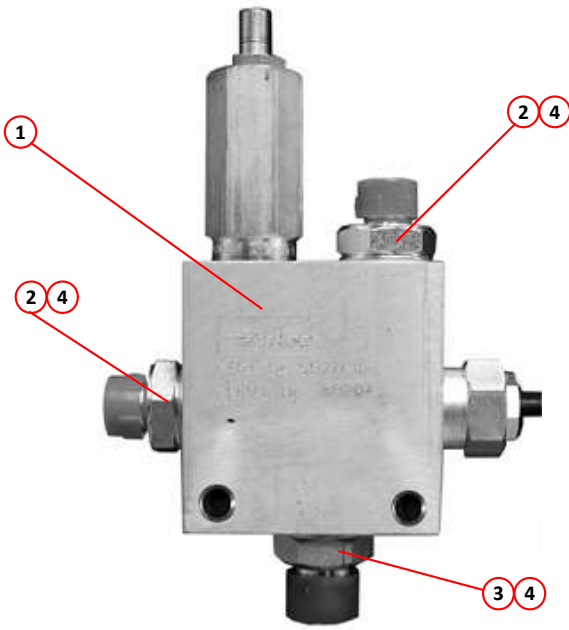

POWER STEERING REGULATOR VALVE

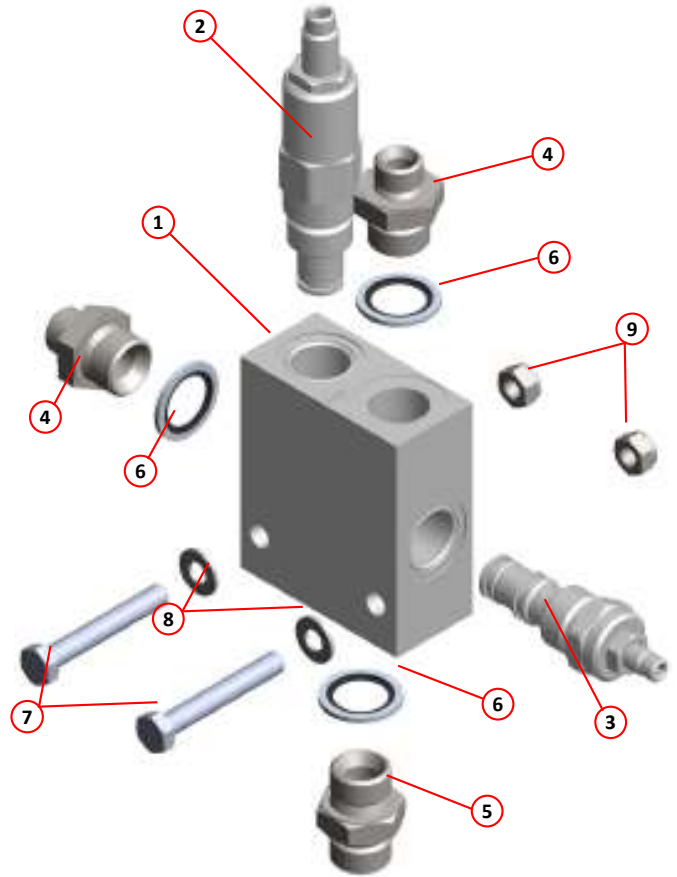

POWER STEERING REGULATOR VALVE (HYDRAFORCE)

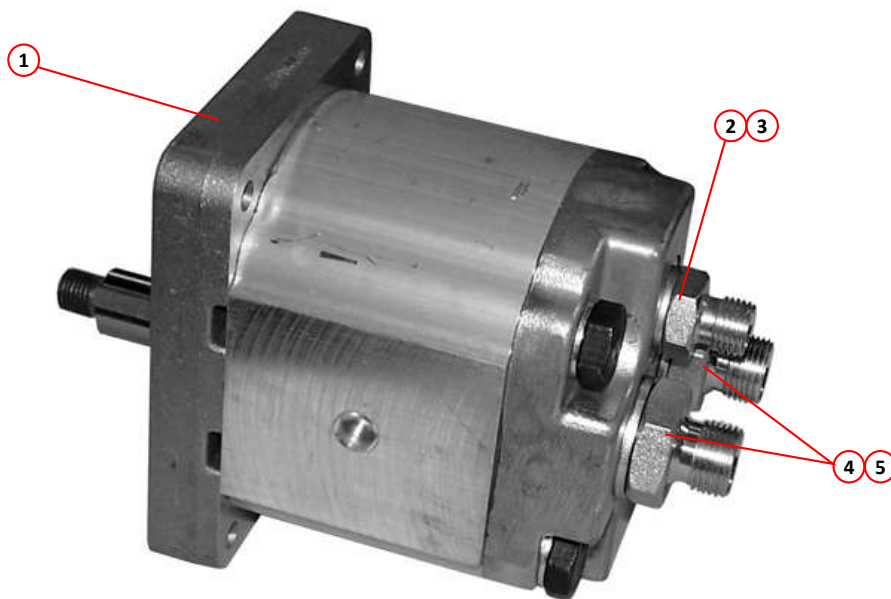

HIGH PRESSURE PUMP DRIVE MOTOR

Item	Part Number	Quantity	Description
Wide Sweep Brush Motor			
1	010749	1	Motor, hydraulic, OMP 200 (Single sweep) Page 106,108
NI	*	1	. Seal, motor, repair kit, OMP 200
2	023503	1	Motor, hydraulic, OMPW 200 (Dual sweep) Page 110
NI	*	1	. Seal, motor, repair kit, OMPW 200
3	011167	2	. Adaptor, M/M, $\frac{1}{2}$ " x $\frac{3}{8}$ " BSP
4	011154	2	. Seal, Dowty, $\frac{1}{2}$ " BSP
5	011241	1	. Plug, $\frac{1}{4}$ " BSP
6	011150	1	. Seal, Dowty, $\frac{1}{4}$ " BSP

Item	Part Number	Quantity	Description
Side/Front Brush Motor			
1	010006	1	Motor, hydraulic, OMP 315 Page 114,118
NI	*	1	. Seal, motor, repair kit, OMP 315
NI	027825	1	. Seal, dust, motor shaft
2	011167	2	. Adaptor, M/M, $\frac{1}{2}$ " x $\frac{3}{8}$ " BSP
3	011154	2	. Seal, Dowty, $\frac{1}{2}$ " BSP
4	011172	2	. Elbow, swivel, M/F, $\frac{3}{8}$ " BSP

Notes:-
 * Please contact Scarab Parts Department regarding these parts.

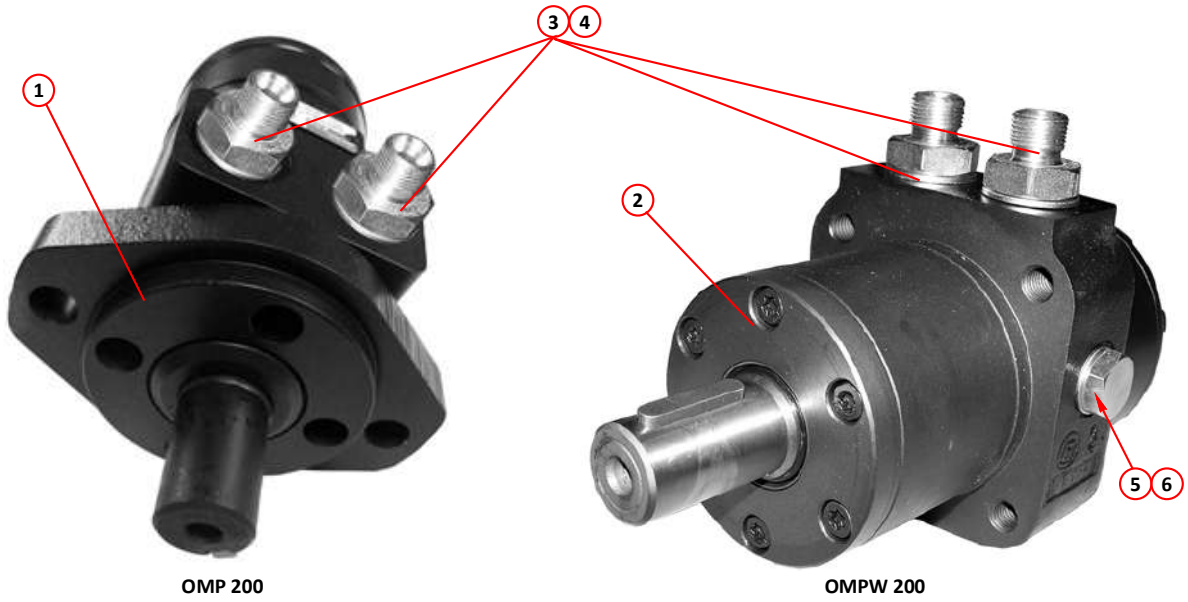

WIDE SWEEP MOTORS

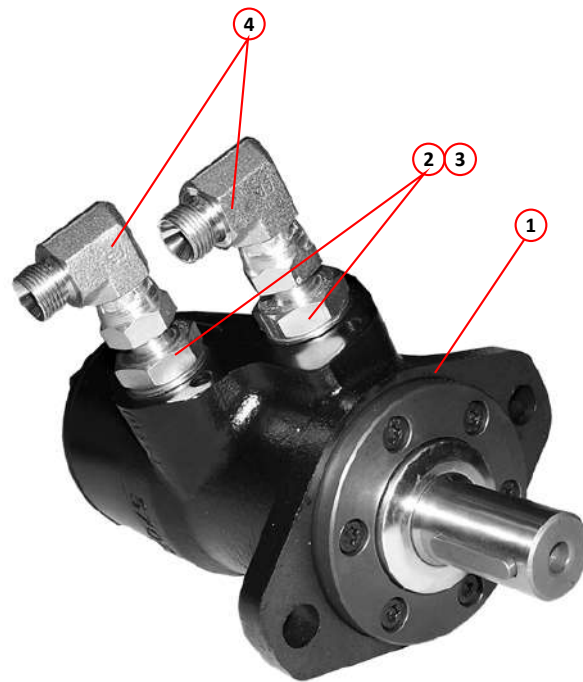

SIDE/FRONT BRUSH MOTOR

<i>Item</i>	<i>Part Number</i>	<i>Quantity</i>	<i>Description</i>
Ram - Suction Nozzle Lift			
1	027119	1	Ram, hydraulic Page 124
2	014473	1	. Bellows
3	027804	1	. Adaptor, restrictor, M/M, $\frac{1}{4}$ " BSP x $\frac{3}{64}$ " orifice, (orange)
4	011152	1	. Seal, Dowty, $\frac{1}{4}$ " BSP

<i>Item</i>	<i>Part Number</i>	<i>Quantity</i>	<i>Description</i>
Ram - Suction Nozzle Tilt			
1	027113	1	Ram, hydraulic Page 122
2	027188	1	. Adaptor, restrictor, M/M, $\frac{1}{4}$ " BSP x 0.6mm orifice, (green)
3	011152	1	. Seal, Dowty, $\frac{1}{4}$ " BSP

<i>Item</i>	<i>Part Number</i>	<i>Quantity</i>	<i>Description</i>
Ram - Wide Sweep Lift			
1	027115	1	Ram, hydraulic Page 112
2	014473	1	. Bellows
3	027188	1	. Adaptor, restrictor, M/M, $\frac{1}{4}$ " BSP x 0.6mm orifice, (green)
4	011152	1	. Seal, Dowty, $\frac{1}{4}$ " BSP
5	024682	2	. Bush, 25 x 20 x 10mm

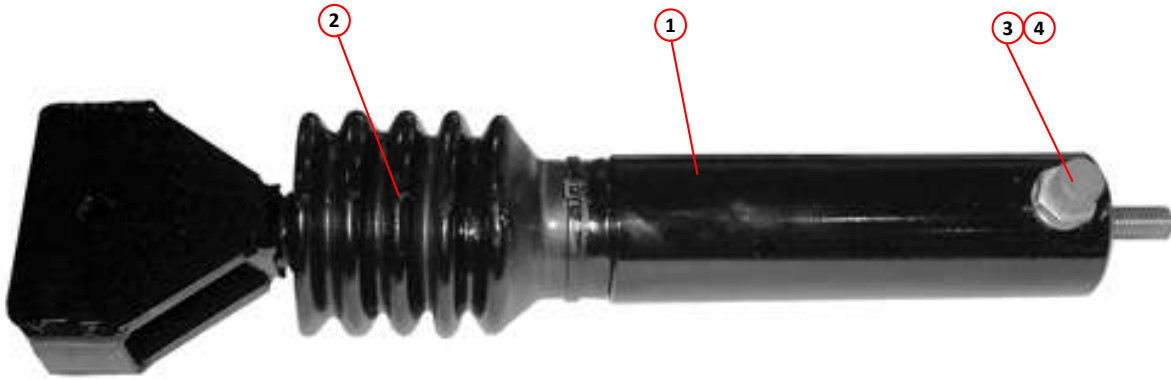

RAM - SUCTION NOZZLE LIFT

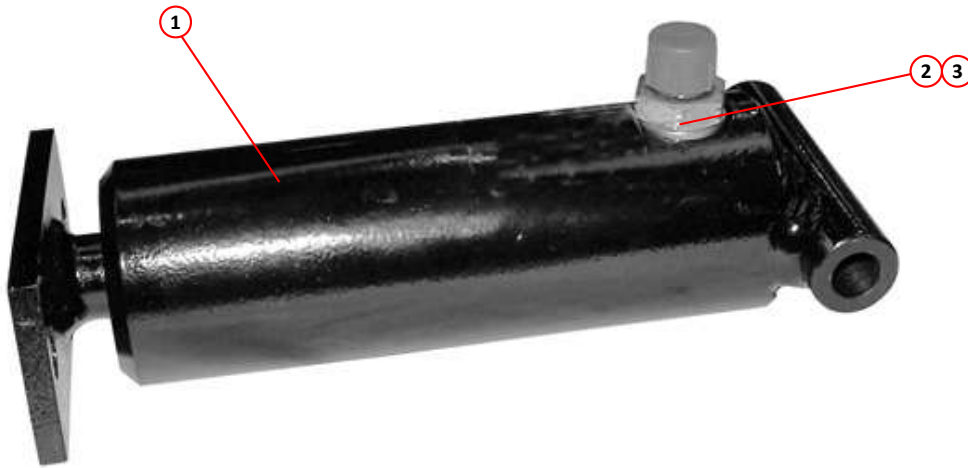

RAM - SUCTION NOZZLE TILT

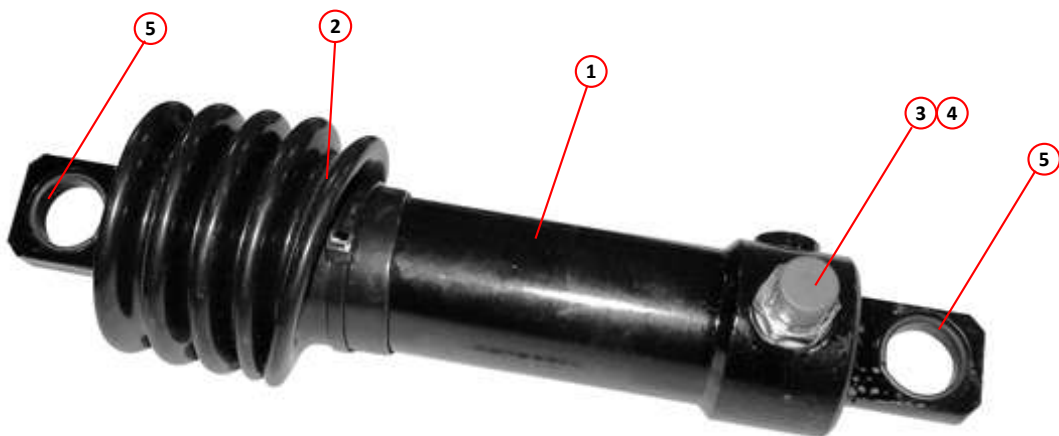

RAM - WIDE SWEEP LIFT

<i>Item</i>	<i>Part Number</i>	<i>Quantity</i>	<i>Description</i>
Ram - Front Brush Lift			
1	027116	1	Ram, hydraulic, complete Page 114
2	021510	1	. Bellows
3	027188	1	. Adaptor, restrictor, M/M, $\frac{1}{4}$ " BSP x 0.6mm orifice, (green)
4	011152	1	. Seal, Dowty, $\frac{1}{4}$ " BSP
5	024682	2	. Bush, 25 x 20 x 10mm

<i>Item</i>	<i>Part Number</i>	<i>Quantity</i>	<i>Description</i>
Ram - Front Brush Swing Out			
1	040350	1	Ram, hydraulic, complete Page 116
2	014473	1	. Bellows
3	027188	1	. Adaptor, restrictor, M/M, $\frac{1}{4}$ " BSP x 0.6mm orifice, (green)
4	011152	1	. Seal, Dowty, $\frac{1}{4}$ " BSP
5	024682	2	. Bush, 25 x 20 x 10mm

<i>Item</i>	<i>Part Number</i>	<i>Quantity</i>	<i>Description</i>
Ram - Side Brush Lift			
1	027114	1	Ram, hydraulic, complete Page 118
2	014473	1	. Bellows
3	027188	1	. Adaptor, restrictor, M/M, $\frac{1}{4}$ " BSP x 0.6mm orifice, (green)
4	011152	1	. Seal, Dowty, $\frac{1}{4}$ " BSP
5	024682	2	. Bush, 25 x 20 x 10mm

<i>Item</i>	<i>Part Number</i>	<i>Quantity</i>	<i>Description</i>
Ram - Side Brush Swing Out			
1	027118	1	Ram, hydraulic, complete Page 120
2	014473	1	. Bellows
3	027188	1	. Adaptor, restrictor, M/M, $\frac{1}{4}$ " BSP x 0.6mm orifice, (green)
4	011152	1	. Seal, Dowty, $\frac{1}{4}$ " BSP
5	024682	2	. Bush, 25 x 20 x 10mm

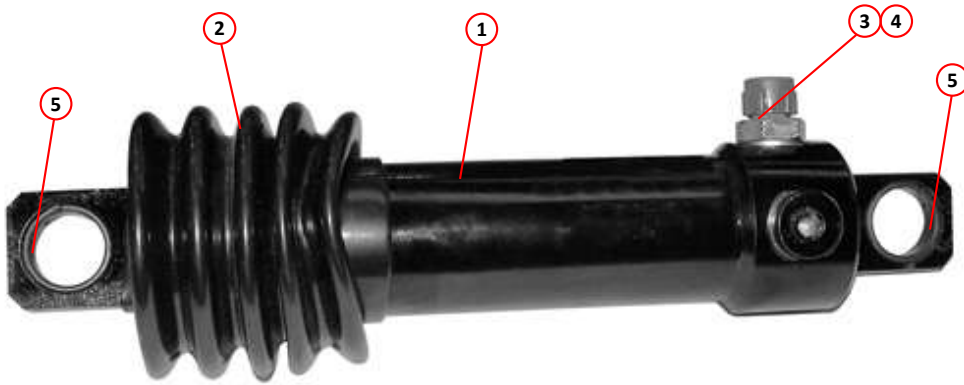

RAM - FRONT BRUSH LIFT

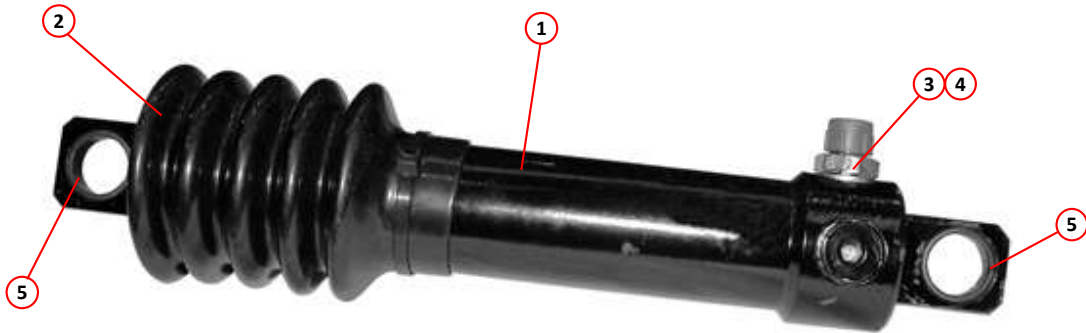

RAM - FRONT BRUSH SWING OUT

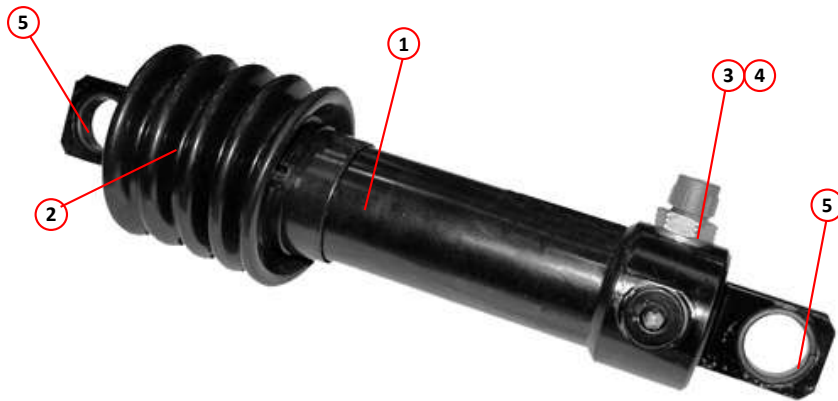

RAM - SIDE BRUSH LIFT

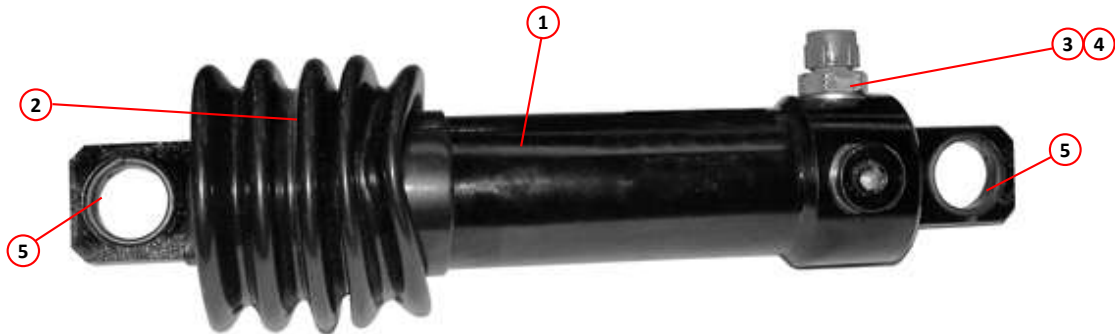

RAM - SIDE BRUSH SWING OUT

Item	Part Number	Quantity	Description
Ram - Hopper Lift			
1	011577	1	Ram, hydraulic (standard) Page 130
NI	012203	1	. Seal, ram (011577), repair kit
NI	026720	2	Ram, hydraulic (Hi-tip 1.3) Page 144
NI	026719	2	Ram, hydraulic (Hi-tip 1.6) Page 144
2	011158	2	. Adaptor, M/M, $\frac{1}{4}$ " BSP
3	011152	2	. Seal, Dowty, $\frac{1}{4}$ " BSP

Item	Part Number	Quantity	Description
Ram - Auto Blanking			
1	022350	AR	Ram, hydraulic Page 138
NI	022776	1	. Seal, repair kit
2	002017	2	. Adaptor, banjo, M/M, $\frac{1}{4}$ " BSP
3	011152	4	. Seal, Dowty, $\frac{1}{4}$ " BSP
4	000211	1	. Nut, hex, clevis locking
5	014469	1	. Clevis
6	023269	1	. . Retaining pin, clevis
7	023270	1	. . Clip, clevis retaining pin

Item	Part Number	Quantity	Description
Ram - Rear Door Open/Close			
1	022511	1	Ram, hydraulic Page 146
NI	022777	1	. Seal, repair kit
2	002017	2	. Adaptor, banjo, M/M, $\frac{1}{4}$ " BSP
3	011152	4	. Seal, Dowty, $\frac{1}{4}$ " BSP

Item	Part Number	Quantity	Description
Ram - Cab Lift Assist			
1	032810	1	Ram, hydraulic Page 96
NI	011629	1	. Seal, repair kit
2	011152	1	. Seal, Dowty, $\frac{1}{4}$ " BSP
3	033748	1	. . Adaptor, restrictor, M/M, 0.5mm, $\frac{1}{4}$ " BSP (Gold)
4	011152	1	. Seal, Dowty, $\frac{1}{4}$ " BSP
5	011269	1	. . Adaptor, bulkhead, M/M, $\frac{1}{4}$ " BSP



RAM - HOPPER LIFT

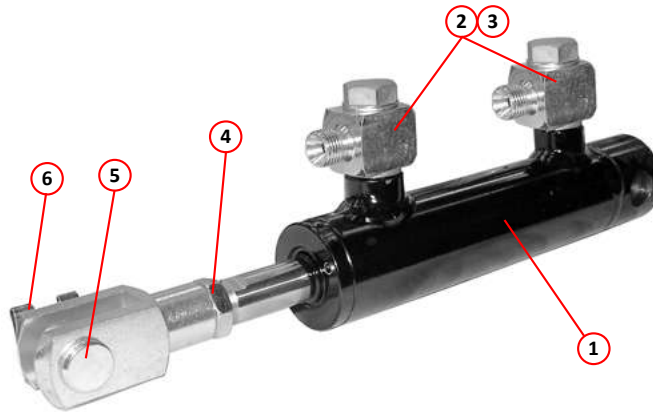

RAM - AUTO BLANKING

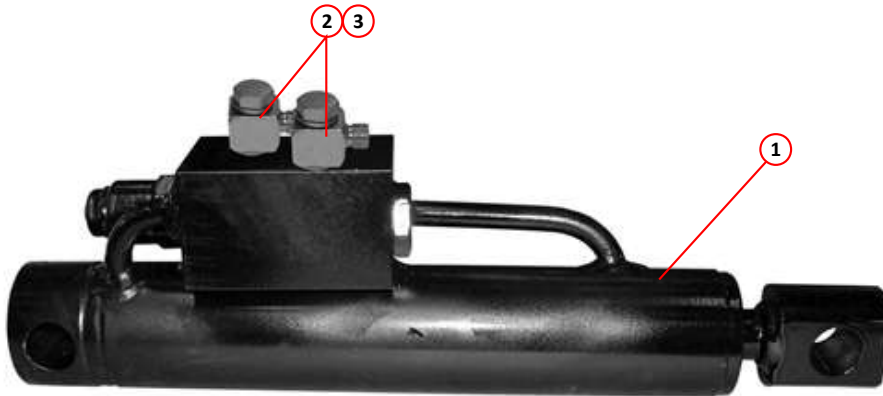

RAM - REAR DOOR OPEN CLOSE

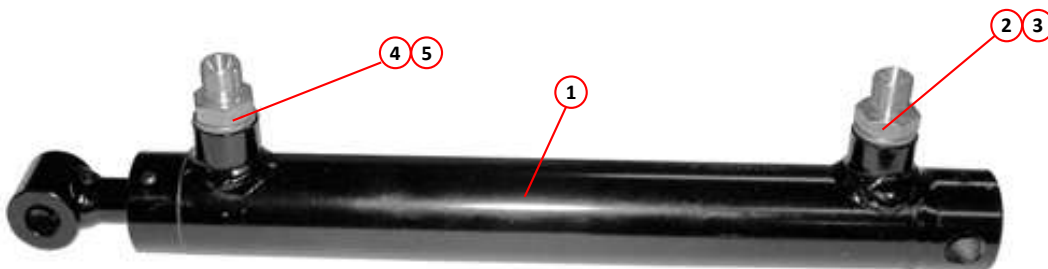

RAM - CAB LIFT ASSIST

Item	Part Number	Quantity	Description
Rear Door Flow Valve and Pressure Control Assembly (Hydraforce)			
1	038018	1	Cetop sub plate
2	023569	1	Valve, control 'E' spool, 12 Volt Page 146
3	026049	2	Coil, solenoid, 12 Volt x 30 Watt (2.5 amps)
4	000137	4	Socket cap head screw, M5 x 50mm
5	011153	4	Seal, Dowty, $\frac{3}{8}$ " BSP
6	010923	1	Hose tail, $\frac{3}{8}$ " BSP x $\frac{3}{8}$ " hose
7	011159	2	Adaptor, M/M, $\frac{3}{8}$ " BSP
8	020903	2	Male stud, $\frac{3}{8}$ " BSP x 12mm steel tube
9	032503	1	Tube, assembly, includes 'O'-rings
10	002107	1	Male stud, $\frac{1}{2}$ " BSP x 12mm steel tube
11	011154	3	Seal, Dowty, $\frac{1}{2}$ " BSP
	041561	1	Valve, relief and flow regulator (inc. manifold, relief and flow regulator valves). . . . Page 146
12	041618	1	Manifold
13	041619	1	Relief valve, RV10-20
14	041621	1	Seal kit, relief valve
15	041620	1	Flow regulator valve, FR10-39
16	041622	1	Seal kit, flow regulator
17	011165	1	Adaptor, M/M, $\frac{1}{2}$ " x $\frac{1}{4}$ " BSP
18	011171	1	Elbow, swivel, M/F, $\frac{1}{4}$ " BSP
19	011160	1	Adaptor, M/M, $\frac{1}{2}$ " BSP
20	011234	1	Hose tail, 90°, $\frac{1}{2}$ " BSP x $\frac{5}{8}$ " hose

Item	Part Number	Quantity	Description
Rear Door Check Valve (Hydraforce)			
	041557	1	Valve regulator, door check (inc. manifold, solenoid and coil) Page 146
1	041609	1	Manifold
2	041610	1	Solenoid valve, SV08-20 N/C
3	041225	1	Coil 12V/17.2 Watts
4	041237	1	Coil nut
5	011152	2	Seal, Dowty, $\frac{1}{4}$ " BSP
6	011158	2	Adaptor, M/M, $\frac{1}{4}$ " BSP
7	011171	2	Elbow, swivel, M/F, $\frac{1}{4}$ " BSP

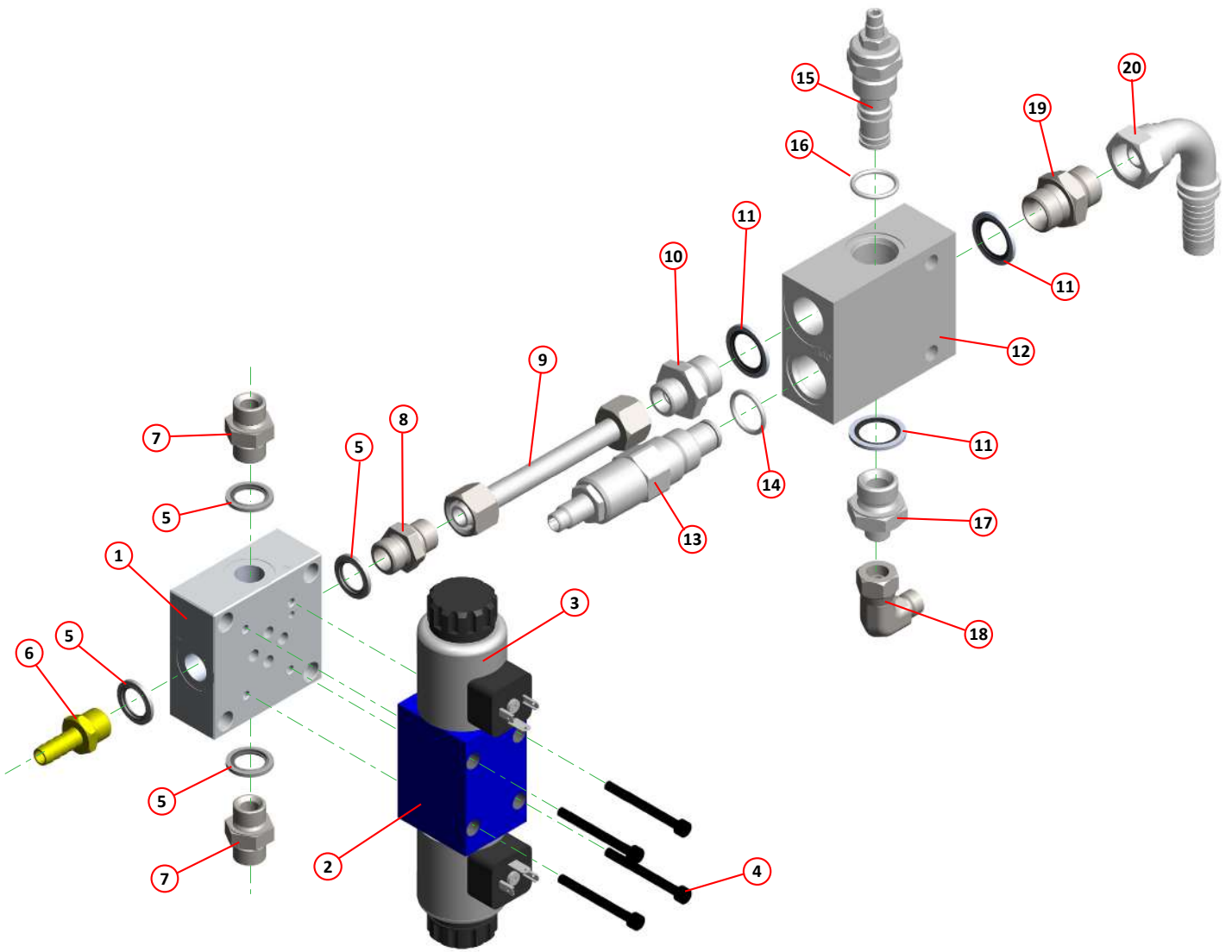

REAR DOOR FLOW VALVE AND PRESSURE CONTROL ASSEMBLY (HYDRAFORCE)

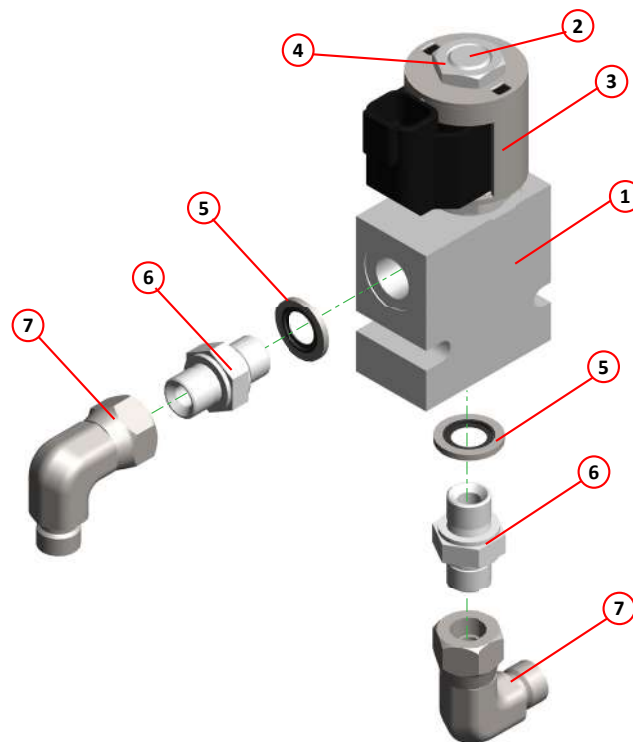

REAR DOOR CHECK VALVE (HYDRAFORCE)

Item	Part Number	Quantity	Description
Rear Door Flow Valve and Pressure Control Assembly (pre-Hydraforce)			
1	038018	1	Cetop sub plate
2	023569	1	Valve, control 'E' spool, 12 Volt Page 146
3	026049	2	. Coil, solenoid, 12 Volt x 30 Watt (2.5 amps)
4	010923	1	. Hose tail, $\frac{3}{8}$ " BSP x $\frac{3}{8}$ " hose
5	011153	4	. Seal, Dowty, $\frac{3}{8}$ " BSP
NI	011159	2	. Adaptor, M/M, $\frac{3}{8}$ " BSP
6	020903	1	. Male stud, $\frac{3}{8}$ " BSP x 12mm steel tube
7	032503	1	. Tube, assembly
8	002107	1	. Male stud, $\frac{1}{2}$ " BSP x 12mm steel tube
9	011154	4	. Seal, Dowty, $\frac{1}{2}$ " BSP
10	025599	1	. Valve, flow and pressure Page 146
11	01110	1	. Adaptor, M/M, $\frac{1}{2}$ " BSP
12	011234	1	. Hose tail, 90°, $\frac{1}{2}$ " BSP x $\frac{5}{8}$ " hose
13	011165	1	. Adaptor, M/M, $\frac{1}{2}$ " x $\frac{1}{4}$ " BSP
14	011171	1	. Elbow, swivel, M/F, $\frac{1}{4}$ " BSP

Item	Part Number	Quantity	Description
Rear Door Check Valve (pre-Hydraforce)			
1	012582	1	Valve, check Page 146
2	022483	1	. Coil, solenoid, 12 Volt x 14 Watt
3	011158	2	. Adaptor, M/M, $\frac{1}{4}$ " BSP
4	011171	2	. Elbow, swivel, M/F, $\frac{1}{4}$ " BSP
5	011152	2	. Seal, Dowty, $\frac{1}{4}$ " BSP

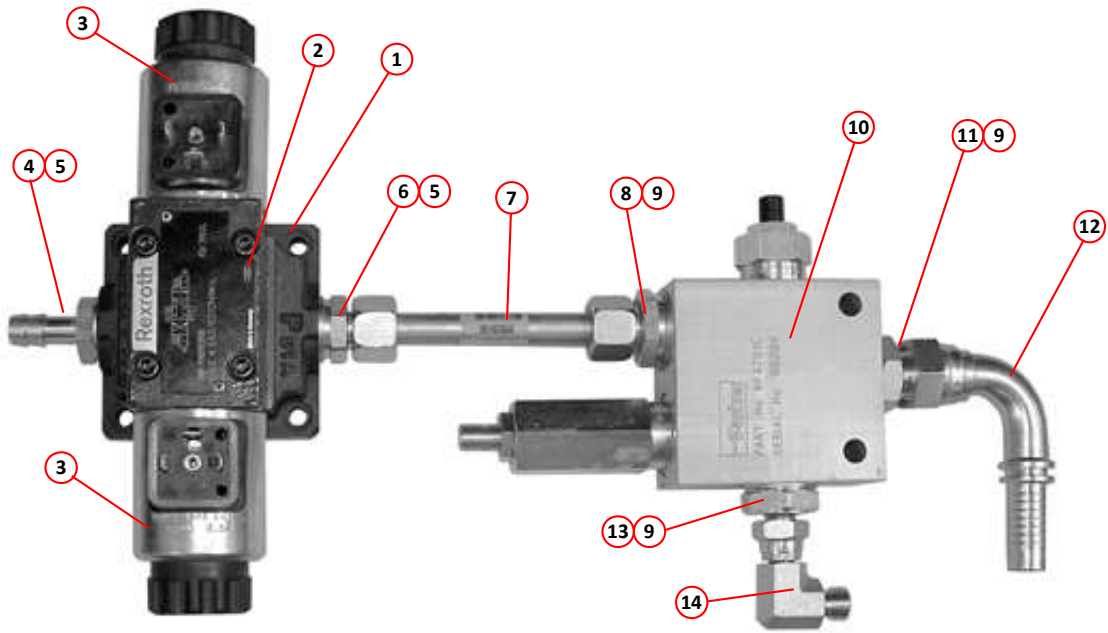

REAR DOOR FLOW VALVE AND PRESSURE CONTROL ASSEMBLY

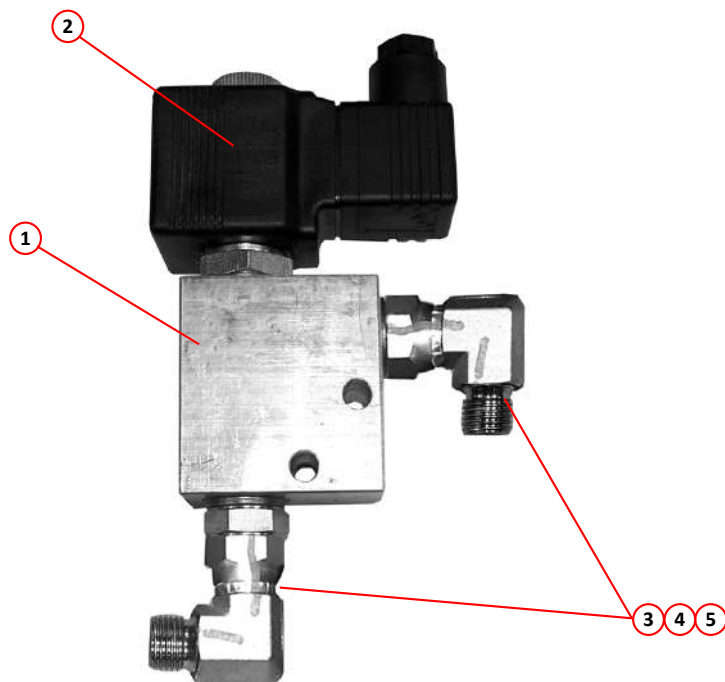

REAR DOOR CHECK VALVE
Hydraulic Systems

<i>Item</i>	<i>Part Number</i>	<i>Quantity</i>	<i>Description</i>
Auto Blanking Valve Single Sweep Assembly			
1	021810	1	Mounting bracket
2	038018	1	Cetop, sub plate
3	000120	4	Bolt, M6 x 45mm
4	011090	4	Plain washer, M6
5	011071	4	Nut, Nyloc, M6
6	011153	4	Seal, Dowty, $\frac{3}{8}$ " BSP
7	011159	1	Adaptor, M/M, $\frac{3}{8}$ " BSP
8	011223	1	Elbow, swivel, $\frac{3}{8}$ " BSP x $\frac{3}{8}$ " hose
9	011199	3	Adaptor, M/M, $\frac{3}{8}$ " x $\frac{1}{4}$ " BSP
10	011171	1	Elbow, swivel, M/F, $\frac{1}{4}$ " BSP
11	023820	1	Valve, control "D" spool, 12 Volt
12	000137	4	Socket cap head screw, M5 x 50mm

<i>Item</i>	<i>Part Number</i>	<i>Quantity</i>	<i>Description</i>
Auto Blanking Valve Dual Sweep Assembly			
1	021810	1	Mounting bracket
2	038018	2	Cetop, sub plate
3	011006	4	Screw, socket cap head, M6 x 70mm
4	011090	4	Plain washer, M6
5	011071	4	Nut, Nyloc, M6
6	011153	8	Seal, Dowty, $\frac{3}{8}$ " BSP
7	011199	6	Adaptor, M/M, $\frac{3}{8}$ " x $\frac{1}{4}$ " BSP
8	011159	1	Adaptor, M/M, $\frac{3}{8}$ " BSP
9	011172	1	Elbow, swivel, M/F, $\frac{3}{8}$ " BSP
10	011223	1	Tee, swivel, nut on run, $\frac{3}{8}$ " BSP
11	002048	1	Elbow, swivel, $\frac{3}{8}$ " BSPF x $\frac{3}{8}$ " hose
12	011171	1	Elbow, swivel, M/F, $\frac{1}{4}$ " BSP
13	011206	1	Tee, swivel, nut on run, $\frac{1}{4}$ " BSP
14	023820	2	Valve, control "D" spool, 12 Volt
15	000137	8	Socket cap head screw, M5 x 50mm

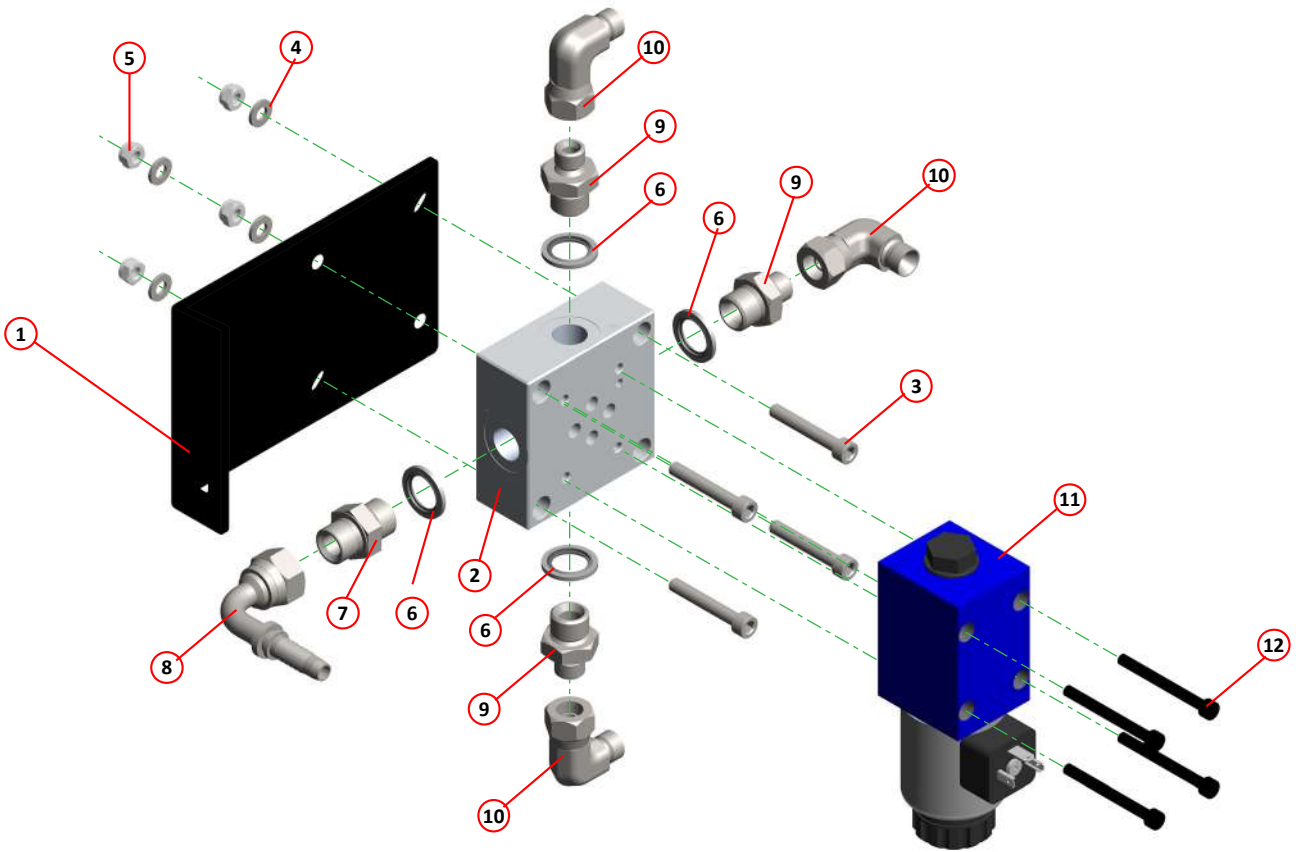

AUTO BLANKING VALVE SINGLE SWEEP ASSEMBLY

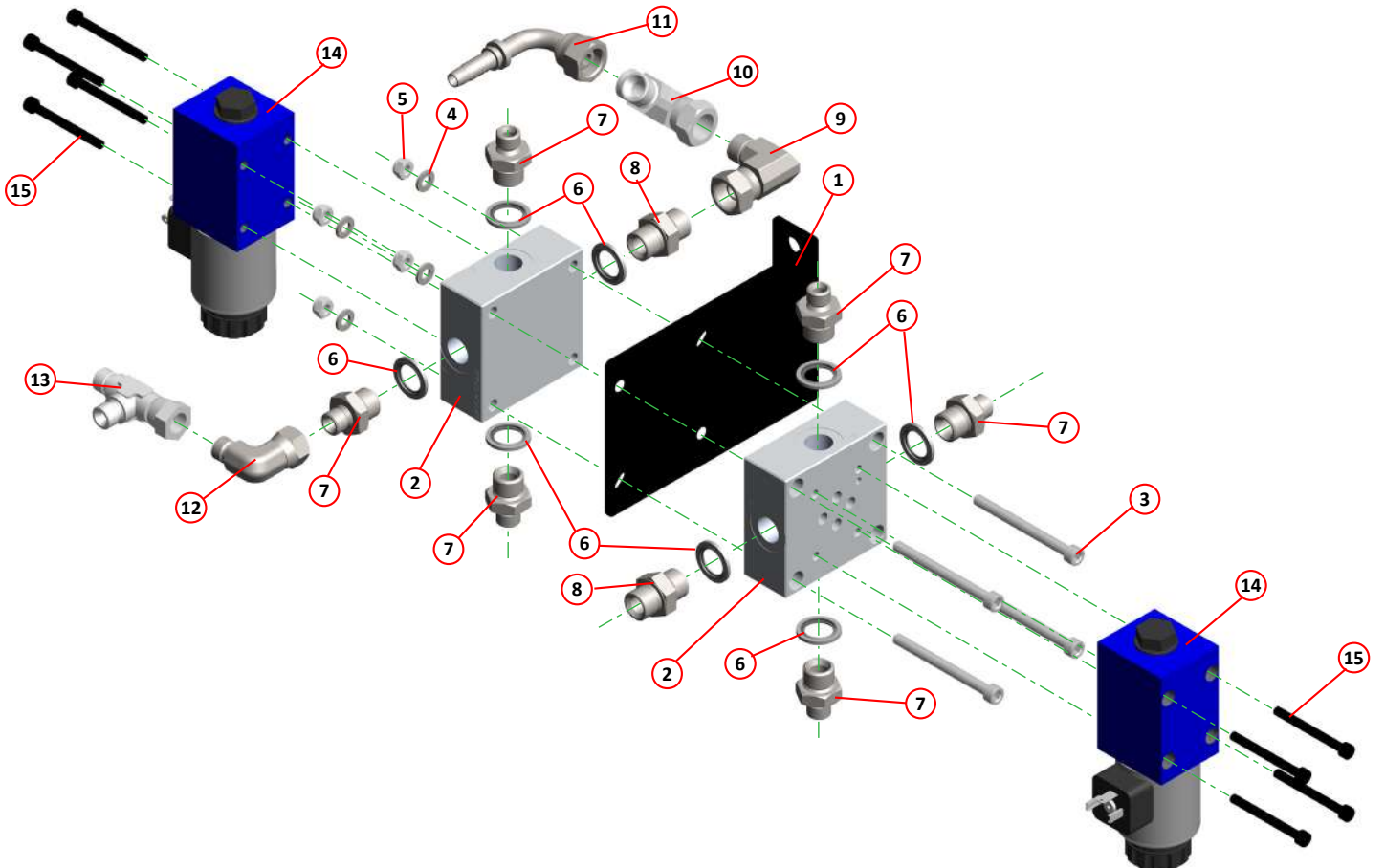

AUTO BLANKING VALVE DUAL SWEEP ASSEMBLY

<i>Part Number</i>	<i>Quantity</i>	<i>Description - From - To</i>
Steel Pipes		
033245	1	Hydraulic Pipe - LF1- LH Front Brush
033246	1	Hydraulic Pipe - LF2 -LH Front Brush
033251	1	Hydraulic Pipe - C1- LH Front Brush Lift
033252	1	Hydraulic Pipe - C2 - LH Front Brush Swing
027696	1	Hydraulic Pipe - Valve Block LH1 - LH Side Brush
027697	1	Hydraulic Pipe - Valve Block LH2 - LH Side Brush
026903	1	Hydraulic Pipe - Block - LH Side Block
026904	1	Hydraulic Pipe - LH2 - LH Side Brush
026922	1	Hydraulic Pipe - C7 - LH Side Brush Lift
026917	1	Hydraulic Pipe - C9 - LH Nozzle
033545	1	Hydraulic Pipe - C6 - LH/RH Nozzle Tilt
033547	1	Hydraulic Pipe - C6 - LH Nozzle Tilt
033548	1	Hydraulic Pipe - C6 - LH Nozzle Tilt (Dual Sweep)
026899	1	Hydraulic Pipe - D - High Pressure Pump
026902	1	Hydraulic Pipe - High Pressure Pump Return
033247	1	Hydraulic Pipe - RF1 - RH Front Brush
033248	1	Hydraulic Pipe - RF2 - RH Front Brush
033249	1	Hydraulic Pipe - C4 - RH Front Brush Lift
026909	1	Hydraulic Pipe - C4 - RH Front Brush Lift
033250	1	Hydraulic Pipe - C5 - RH Front Brush Swing
026910	1	Hydraulic Pipe - C5 - RH Front Brush Swing
026906	1	Hydraulic Pipe - RH1 - RH Side Brush
026907	1	Hydraulic Pipe - RH2 - RH Side Brush
026911	1	Hydraulic Pipe - C3 RH Side Brush Swing
026916	1	Hydraulic Pipe - C10 - RH Nozzle
033546	1	Hydraulic Pipe - C6 - RH Nozzle Tilt
027694	1	Hydraulic Pipe - Wide Sweep - Manifold
026908	1	Hydraulic Pipe - T - Wide Sweep
026905	1	Hydraulic Pipe - Wide Sweep Return
027695	1	Hydraulic Pipe - Block - Wide Sweep
026923	1	Hydraulic Pipe - C8 - Wide Sweep Lift
026914	1	Hydraulic Pipe - A - Hopper
026915	1	Hydraulic Pipe - B - Hopper
026918	1	Hydraulic Pipe - Fan Pump - C

<i>Part Number</i>	<i>Quantity</i>	<i>Description - From - To</i>
Rubber Hoses - LH Sweep Machines Only		
001081	2	Hose $\frac{3}{8}$ " x 650 (90/90°) - Side Brush
001130	1	Hose $\frac{1}{4}$ " x 265 (ST/90°) - Wide Sweep Lift
001105	1	Hose $\frac{1}{4}$ " x 400 (ST/90°) - S/Pipe - Nozzle Lift
001105	1	Hose $\frac{1}{4}$ " x 400 (ST/90°) - Nozzle Lift
001108	1	Hose $\frac{1}{4}$ " x 750 (ST/90°) - Block - Fan Pump
001120	1	Hose $\frac{3}{8}$ " x 432 (ST/90°) - S/Pipe - Tee
001088	2	Hose $\frac{3}{8}$ " x 580 (ST/90°) - S/Pipe - Wide Sweep
001227	1	Hose $\frac{3}{8}$ " x 680 (ST/90°) - Restrictor - Steering Box
001227	1	Hose $\frac{3}{8}$ " x 680 (ST/90°) - Box - Return Manifold

Part Number	Quantity	Description - From - To
Rubber Hoses - RH Sweep Machines Only		
001082	2	Hose $\frac{3}{8}$ " x 700 (90°/90°) - Side Brush
001105	1	Hose $\frac{1}{4}$ " x 400 (ST/90°) - Wide Sweep Lift
001108	1	Hose $\frac{1}{4}$ " x 750 (ST/90°) - S/Pipe - Fan Pump
010980	1	Hose $\frac{1}{4}$ " x 432 (ST/90°) - Hopper Valve - S/Pipe
001024	1	Hose $\frac{1}{4}$ " x 770 (ST/90°) - Hopper Ram - S/Pipe
011340	1	Hose $\frac{1}{4}$ " x 3000 (ST/90°) - Street Wash Valve - Front Spray Bar
001090	1	Hose $\frac{3}{8}$ " x 880 (ST/90°) - Sweep/Wash Valve - G/Pump
001226	1	Hose $\frac{3}{8}$ " x 530 (ST/90°) - Restrictor - Steering Box
001226	1	Hose $\frac{3}{8}$ " x 530 (ST/90°) - Box - Return Manifold

Part Number	Quantity	Description - From - To
Rubber Hoses - Dual Sweep Machines Only		
001019	2	Hose $\frac{3}{8}$ " x 820 (ST/90°) S/Pipe - Wide Sweep
001105	1	Hose $\frac{3}{8}$ " x 400 (ST/90°) S/Pipe - Wide Sweep Lift

Part Number	Quantity	Description - From - To
Rubber Hoses - Common to LH, RH and Dual Sweep Machines		
001070	1	Hose $\frac{5}{8}$ " x 4350 (ST/90°) - Fan Return
001075	1	Hose $\frac{1}{2}$ " x 500 (ST/90°) - Sauer Pump -Filter
001076	1	Hose $\frac{1}{2}$ " x 600 (ST/90°) - Sauer Pump - Filter
001163	4	Hose $\frac{3}{8}$ " x 1030 (ST/90°) - Front Brush Motor
001085	1	Hose $\frac{3}{8}$ " x 4300 (ST/90°) - High Pressure Pump - Hose Reel
011342	1	Hose $\frac{3}{8}$ " x 2540 (ST/90°) - Cooler Motor - G/Pump 2
001167	1	Hose $\frac{3}{8}$ " x 1200 (ST/ST) - Cooler Motor - Restrictor
001084	1	Hose $\frac{3}{8}$ " x 2330 (ST/90°) - Restrictor - Air Con Pump
011342	1	Hose $\frac{3}{8}$ " x 2540 (ST/90°) - Air Con Pump - Tee
001088	1	Hose $\frac{3}{8}$ " x 580 (ST/90°) - Tee - Sweep Wash Valve
011342	1	Hose $\frac{3}{8}$ " x 2540 (ST/90°) - Air Con Pump - Restrictor
001100	2	Hose $\frac{1}{4}$ " x 460 (ST/90°) - Front Brush Swing
001101	2	Hose $\frac{1}{4}$ " x 1125 (ST/90°) - Front Brush Lift
001105	1	Hose $\frac{1}{4}$ " x 400 (ST/90°) - DFR Valve - Suction Fan Valve

Electrical System

<i>Assembly/Description</i>	<i>Page</i>
Electrical Components - Cab	216
Fuse Panel Assembly and Associated Parts	218
Node 4	220
Node 7	220
Node 8	220
Electrical - Wiring Looms	222
Electrical - In Cab	223
Electrical - Switches	223
Electrical - Gantry/Chassis/Hopper	223
Electrical - Head, Rear and Marker Lamps	224
Electrical - Work Lamps, Beacons and Light Bars	224

<i>Item</i>	<i>Part Number</i>	<i>Quantity</i>	<i>Description</i>
Electrical Components - Cab			
1		1	Keypad, main control panel complete Page 86,223
2	037575*	1	. Keypad & enclosure assembly
3	037053	1	. Enclosure, back
4	037055	1	. . Fixing plate, main control panel
	000304	8	. . . Screw, socket button-head, M4 x 10mm long
	000134	8	. . . Nut, M4 Nyloc
5		1	Auxiliary control panel Page 86,223
6		1	Auxiliary control panel, new fan symbols Page 86,223
7	038103*	1	. Keypad & enclosure assembly
8	037608*	1	. Keypad & enclosure assembly, new fan symbols
9	036873	1	. Multi-function switch
10	037057	1	. Support plate
11	037056	1	. Back plate, LH mounting
11	037058	1	. Back plate, RH mounting
	000380	5	. . Screw, socket button head, M5 x10mm long
12	042354	1	Display screen (programmed) Page 86,223
13	036799**	3	Node, cabinet module (CR2012) Page 88,223
14	038985**	3	Node, E9G212, cabinet module (CR2012) Page 88,223
15	039060	2	LED current source Page 88,223
16	040717	1	Camera monitor. Page 90
17	***	1	Hopper controller complete Page 88,223
18	044294	1	Hopper controller, complete includes holster Page 88

Notes:-

* The keypad and its enclosure are factory bonded and must be purchased as such.

** Please contact Scarab Parts Department regarding these nodes.

*** As of March 2016 if you have one of these controllers then please order item 18 instead.

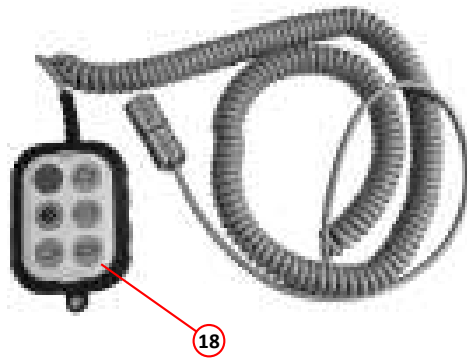
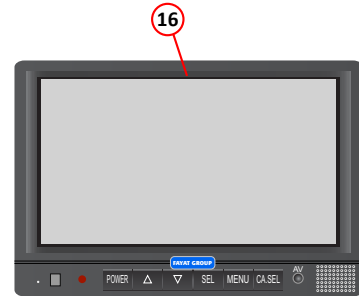
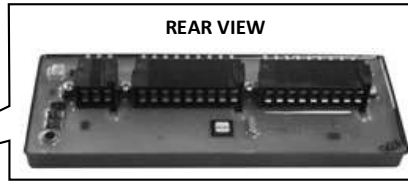
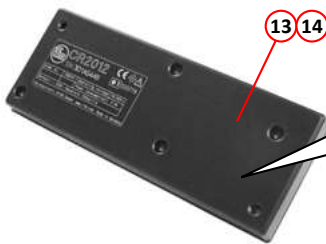
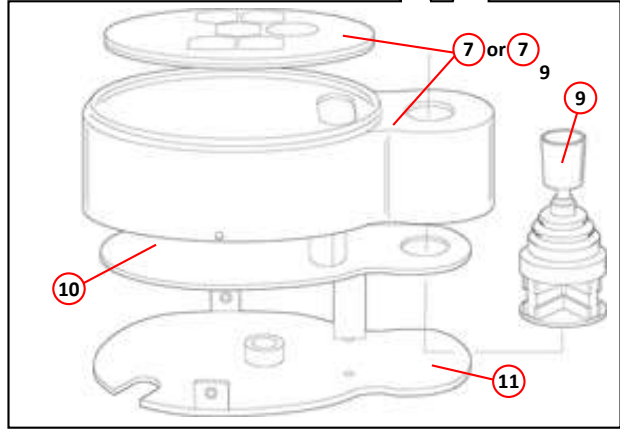
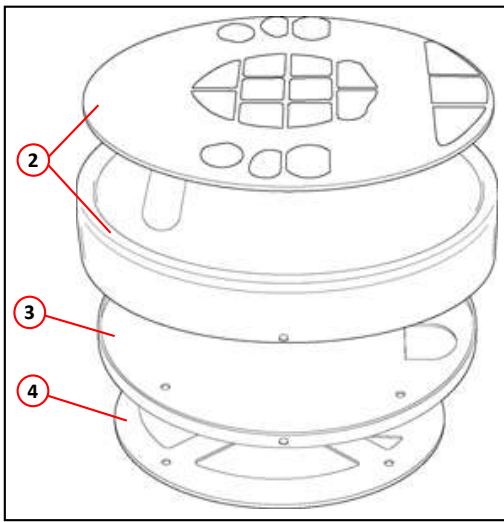

ELECTRICAL COMPONENTS - CAB

Item	Part Number	Quantity	Description
Fuse Panel Assembly and Associated Parts			
1	011768	1	Relay, crossover, 12 Volt 30 Amp
2	011768	1	Relay, crossover, 12 Volt 30 Amp
3	011768	1	Relay, crossover, 12 Volt 30 Amp
4	038558	1	Relay, directional indicator, 12 Volt
5	011768	1	Relay, crossover, 12 Volt 30 Amp
6	011768	1	Relay, crossover, 12 Volt 30 Amp
7	011768	1	Relay, crossover, 12 Volt 30 Amp
8	011768	1	Relay, crossover, 12 Volt 30 Amp
9	032804	1	Relay, 12 Volt 70 Amp with diode
10	032804	1	Relay, 12 Volt 70 Amp with diode
11	032804	1	Relay, 12 Volt 70 Amp with diode
12	032804	1	Relay, 12 Volt 70 Amp with diode
13	011768	1	E Fuses Relay, crossover, 12 Volt 30 Amp
14	031668	1	Intermittent wash/wipe control unit
NI	038891	1	Fuse/relay panel frame. LH drive Page 88
15	038892	1	Fuse/relay panel frame. RH drive (shown) Page 88
NI	039065	1	. 12volt to 5volt power supply (behind fuse board) Page 88,223
16	031996	1	. Fuse holder, 6-way (Spares)
17	*		. Fuses
	004485	4	. . 2 Amp, blade type
	014286	21	. . 5 Amp, blade type
	014288	5	. . 10 Amp, blade type
	014289	11	. . 15 Amp, blade type
	014290	2	. . 20 Amp, blade type
	014292	3	. . 30 Amp, blade type
18	042336	1	Node 03, Mobile Controller CR0020 (programmed) Page 88,223
NI	039116	1	Label, fuse and relay information. LH drive
NI	039117	1	Label, fuse and relay information. RH drive
NI	038816	1	Wiring loom, Node 03, Cab Page 222

Notes:-

* Does not identify spare or option fuses.

For left hand drive machines the layout of the fuses is reversed i.e. the columns are A, B, C, D, E.

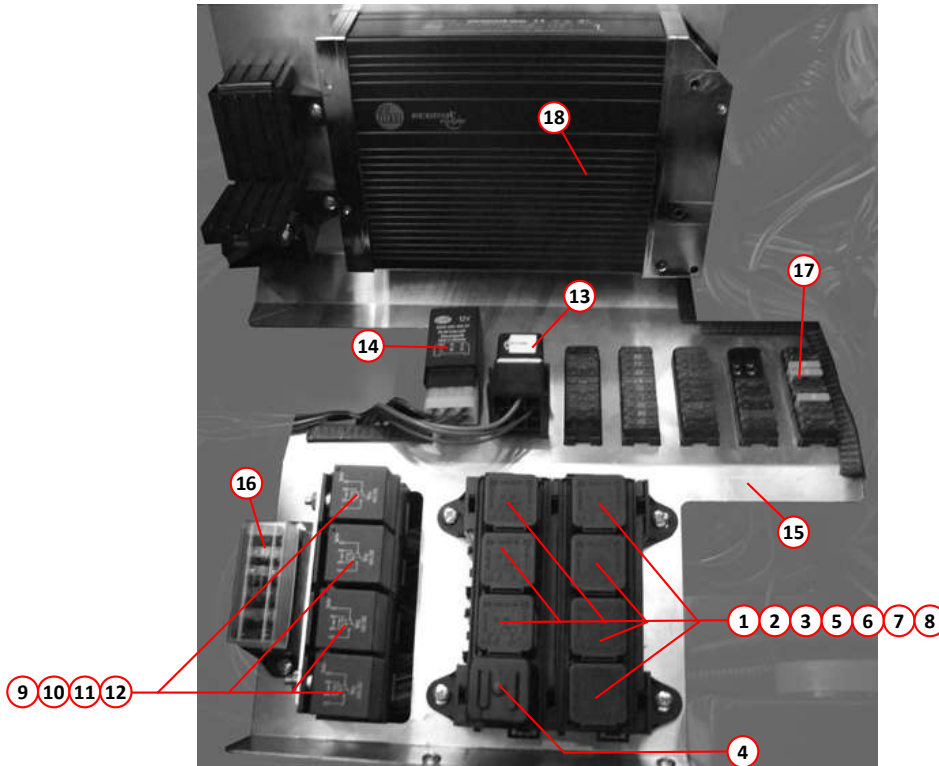

RIGHT HAND DRIVE

		FUSES					
		E	D	C	B	A	
14	13	30A	OPTION	5A	5A	30A	1
		15A	OPTION	5A	5A	5A	2
		2A	OPTION	5A	5A	5A	3
		2A	OPTION	5A	5A	10A	4
		15A	15A	15A	5A	5A	5
		5A	10A	15A	5A	20A	6
		2A	15A	15A	5A	5A	7
		2A	30A	5A	5A	15A	8
		5A	20A	15A	5A	10A	9
		15A	15A	10A	5A	10A	10

	9	1	5
	10	2	6
	11	3	7
	12	4	8

<p style="text-align: center; margin: 0;">RELAY 12V - 30A - 011768</p> <table style="width: 100%; border: none;"> <tr> <td style="width: 50%; border: none;">1 - BEACON</td> <td style="width: 50%; border: none;">6 - HEATER</td> </tr> <tr> <td style="border: none;">2 - DIPPED BEAM</td> <td style="border: none;">7 - NEUTRAL START</td> </tr> <tr> <td style="border: none;">3 - MAIN BEAM</td> <td style="border: none;">8 - WATER PUMP</td> </tr> <tr> <td style="border: none;">5 - AIR CON</td> <td style="border: none;">13 - E FUSES</td> </tr> </table>	1 - BEACON	6 - HEATER	2 - DIPPED BEAM	7 - NEUTRAL START	3 - MAIN BEAM	8 - WATER PUMP	5 - AIR CON	13 - E FUSES	<p style="text-align: center; margin: 0;">RELAY 12V - 70A (with diode) - 013458</p> <table style="width: 100%; border: none;"> <tr> <td style="width: 50%; border: none;">9 - MAIN</td> <td style="width: 50%; border: none;">10 - GLOW PLUGS</td> </tr> <tr> <td style="border: none;">11 - FUEL HEATER</td> <td style="border: none;">12 - STARTER</td> </tr> </table>	9 - MAIN	10 - GLOW PLUGS	11 - FUEL HEATER	12 - STARTER
1 - BEACON	6 - HEATER												
2 - DIPPED BEAM	7 - NEUTRAL START												
3 - MAIN BEAM	8 - WATER PUMP												
5 - AIR CON	13 - E FUSES												
9 - MAIN	10 - GLOW PLUGS												
11 - FUEL HEATER	12 - STARTER												
<p style="text-align: center; margin: 0;">RELAY 12V - 038558</p> <p style="margin: 0;">4 - DIRECTIONAL INDICATORS</p>	<p style="text-align: center; margin: 0;">RELAY 12V - 031668</p> <p style="margin: 0;">14 - WIPER CONTROL UNIT</p>												

FUSE LIST

- A1 - MAIN
- A2 - CAB INTERIOR LIGHT, ACCESSORY SOCKET
- A3 - SIDE LIGHTS
- A4 - HAZARD LIGHTS & HORN
- A5 - DIRECTIONAL INDICATORS
- A6 - HEADLIGHTS
- A7 - BRAKE LIGHTS
- A8 - F/R LEVER, NODE 03 VBBs AND 5v REG.
- A9 - WIPERS
- A10 - BEACONS
- B1 - LH FRONT SIDE & TAIL LIGHT
- B2 - RH FRONT SIDE & TAIL LIGHT
- B3 - LH MAIN BEAM
- B4 - RH MAIN BEAM
- B5 - LH DIPPED BEAM
- B6 - RH DIPPED BEAM
- B7 - REAR FOG LIGHT
- B8 - REVERSE LIGHT
- B9 - NODE 1.0 AND NODE 1.1
- B10 - NODE 0.0
- C1 - BOSCH ECU IGNITION FEED
- C2 - CLUSTER IGNITION AND ROAD SPEED SENSOR
- C3 - NODE 2 IGNITION FEED
- C4 - HEATER RELAY
- C5 - NODE 3 VBB_o
- C6 - NODE 4 VBB_o
- C7 - KEY SWITCH SUPPLY
- C8 - EOBD, CLUSTER AND NODE 2
- C9 - HEATER
- C10 - WATER PUMP
- D1 - PERMANENT FEED
- D2 - CAMERA FEED
- D3 - IGNITION FEED
- D4 - IGNITION FEED
- D5 - FUEL SENSOR, THROTTLE VALVE ACTUATOR & EGR VALVE ACTUATOR POWER
- D6 - ECU POWER
- D7 - ECU POWER
- D8 - STARTER COIL
- D9 - FUEL HEATER
- D10 - NODE 4 VBB_r
- E1 - E FUSES
- E2 - NODE 7 VBB_o
- E3 - NODE 4 VBBs
- E4 - FAN AND HOPPER SENSNORS
- E5 - NODE 3 VBB_r
- E6 - NODE 7 AND NODE 8 VBBs
- E7 - HOPPER CONTROLLER
- E8 - REVERSE VALVE
- E9 - MOTOR VALVE
- E10 - NODE 8 VBB_o

FUSE PANEL ASSEMBLY CAN bus 3

<i>Item</i>	<i>Part Number</i>	<i>Quantity</i>	<i>Description</i>
Node 4			
1	039163	1	Node mounting bracket Page 52
	011010	4	. Setscrew, hex, M8 x 20mm
	011092	4	. . Washer, M8
	011093	4	. . Washer, spring, M8
2	039164	1	. Node cover bracket Page 52
	011001	4	. . Setscrew, hex, M6 x 16mm
3	042336	1	. Node 04, Mobile Controller CR0020 (programmed) Page 52,223
	000137	4	. . Screw, socket cap head, M5 x 50mm
	000155	4	. . Nut, hex, M5, Nyloc
4	038861	1	. Wiring loom, Node 04 Page 222

<i>Item</i>	<i>Part Number</i>	<i>Quantity</i>	<i>Description</i>
Node 7 - Option			
1	038885	1	Mounting plate for Node 07, Compact Module CR2031 Page 52
	011011	3	. Setscrew, hex, M8 x 25mm
2	038214	1	. Node 07, Compact Module CR2031 Page 52,223
	000422	3	. . Screw, socket cap head, M5 x 25mm
3	039059	AR	. . M12 Plug/Valve Type A (1m long)
4	038228	1	. . Wiring loom, Node 07 Page 222

<i>Item</i>	<i>Part Number</i>	<i>Quantity</i>	<i>Description</i>
Node 8 - Option			
1	039374	1	Mounting plate for Node 08, Compact Module CR2031 Page 46
	011011	3	. Setscrew, hex, M8 x 25mm
2	038214	1	. Node 08, Compact Module CR2031 Page 46,223
	000422	3	. . Screw, socket cap head, M5 x 25mm
3	039059	AR	. . M12 Plug/Valve Type A (1m long)
4	039305	1	. . Wiring loom, Node 08 Page 222

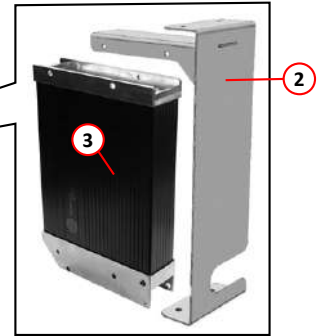
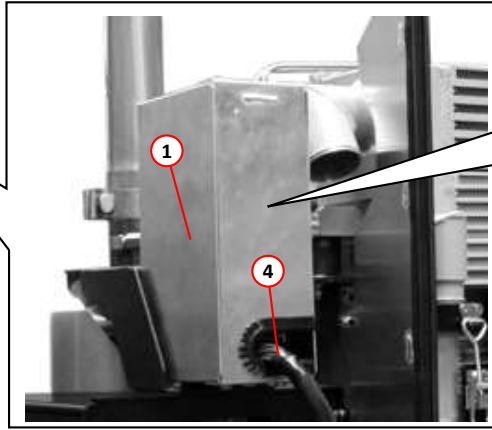
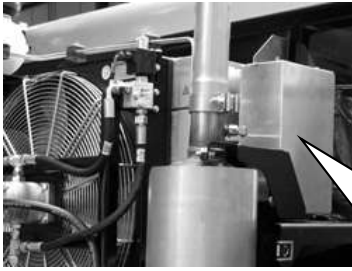

NODE 4

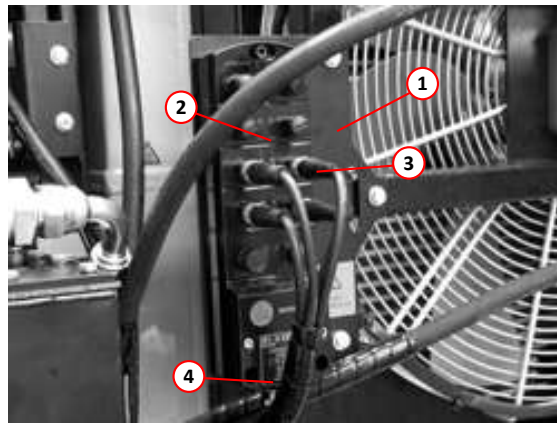

NODE 7 - Option

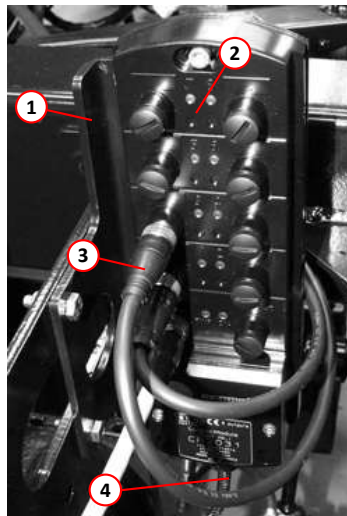

NODE 8 - Option

<i>Part Number</i>	<i>Quantity</i>	<i>Description</i>
Electrical - Wiring Looms		
031400	1	Wiring loom, RH Valeo lights
031399	1	Wiring loom, LH Valeo lights
032846	1	Cable, alternator to starter
032851	1	Cable, battery to cab (positive)
032852	1	Cable, earth point to cab (negative)
032916	1	Wiring loom, Rear Valeo lights
033997	1	Wiring loom - Condenser/Radiator Page 102
036912	1	Wiring loom, Main control panel keypad Page 86
036913	1	Wiring loom, Auxiliary control panel (door pod) Page 86
036916	1	Wiring loom, Display screen Page 86
037075	1	Wiring loom 'K', ECU
037773	1	Cable, earth point to battery (negative)
037774	1	Cable, battery to starter (positive)
038164	1	Wiring loom, Twin core, Tyco, positive
038165	1	Wiring loom, Twin core, Tyco, Earth
038228	1	Wiring loom, Node 07 (option)
038816	1	Wiring loom, Node 03 Page 218
038861	1	Wiring loom, Node 04 Page 220
040964	1	Wiring loom V3, Node 04, Deutsch (Hydraforce)
038925	1	Wiring loom, CAN Fox programming
039000	1	Wiring loom, hopper controls, cab
039305	1	Wiring loom, Node 08 (option)
039035	1	Wiring loom, Hydro Drive
041306	1	Wiring loom, Hydro Drive (Hydraforce)
039059	AR	M12 Plug/Valve Type (A), 1m long
041424	AR	M12 Plug with cable and Deutsch DT 2 Way 1M (Hydraforce)
039257	AR	M12 Plug to M12 Socket jumper, 2m long
039705	AR	M12 Plug with cable and Deutsch DT 2 Way 2M (Hydraforce)
039423	1	Wiring loom, headlights
040718	1	Wiring loom, Rear camera (2.5mtr)
040719	1	Wiring loom, Rear camera (5mtr)
040156	1	Wiring loom, V3 Cab, VM Minor (NSSTA)
040157	1	Wiring Loom, RH Hella Lights, V3 Minor (NSSTA)
040158	1	Wiring Loom, LH Hella Lights, V3 Minor (NSSTA)
040159	1	Wiring Loom, HI Level Brake Light, V3 Minor (NSSTA)
040160	1	Wiring Loom, Reverse Lamp, V3 Minor (NSSTA)
040909	1	Wiring Loom, Euro5 Engine ECU

Part Number	Quantity	Description
Electrical - In Cab		
	1	Main control panel Page 86,216
	1	Auxiliary control panel Page 86,216
	1	Auxiliary control panel, new fan symbols Page 86,216
042354	1	Display screen (programmed) Page 86,216
042336	1	Node 03, Mobile controller CR0020 (programmed) Page 88,218
036799*	3	Node, cabinet module (CR2012) Page 88,216
038985*	3	Node, E9G212, cabinet module (CR2012) Page 88,216
039060	2	LED current source Page 88,216
039065	1	12volt to 5volt power supply (behind fuse board) Page 88,218
031599	1	Radio/CD player
031745	1	Speakers, flush type
013749	1	Interior light
028108	1	Socket 12 volt
013239	4	Pilot lamps (Dash board)
035201	1	Wiper motor Page 88
037074	1	Hopper controller complete Page 88,216
041534	1	Camera splitter Page 90
041289	1	Voltage Stabiliser Page 86

Part Number	Quantity	Description
Electrical - Switches		
032910	2	Handbrake/brake light switch Page 78
032627	1	Sensor, Hopper Raise Page 46
036049	1	Battery isolator
036187	1	. Mounting bracket
024064	1	Load sensor, wobble switch Page 58
031406	2	. Switch, off/on Page 86
031407	1	. Switch, off/on/on Page 86
031408	1	. Switch, hazard warning lights Page 86
038997	1	. Switch, momentary Page 86

Part Number	Quantity	Description
Electrical - Gantry/Chassis/Hopper		
037935**	1	ECU Page 52
042336	1	Node 04, Mobile controller CR0020 (programmed) Page 52,220
038214	1	Node 07, Compact Module CR2031 (option) Page 52,220
038214	1	Node 08, Compact Module CR2031 (option) Page 46,220
037169	1	Battery, 12 Volt 110 Ah
026866	1	. Electric water pump Page 50,154
039336	1	High level brake lightbar Page 132
040354	1	Rear camera Page 132,146

Notes:-

- * Please contact Scarab Parts Department regarding these Nodes.
- ** ECU needs to be matched to engine number, please contact Scarab Parts Department.

<i>Part Number</i>	<i>Quantity</i>	<i>Description</i>
Electrical - Head, Rear and Marker Lamps		
034847	2	Headlight main beam & side light Page 82
011499	2	. Bulb headlight, 12 Volt 55 Watt Page 82
011500	2	. Bulb sidelight, 12 Volt 4 Watt Page 82
034848	2	Headlight dip beam Page 82
011499	2	. Bulb headlight, 12 Volt 55 Watt Page 82
034850	2	Front turn signal Page 82
004416	2	. Bulb front turn signal Page 82
028191	1	Bulb kit (France only)
030668	1	Rear lamp LH (pre April 2013)
030669	1	Rear lamp RH (pre April 2013)
030952	1	Lens, rear lamp (pre April 2013)
014677	1	Socket, connector, rear lamp (pre April 2013)
034187	1	Guard assembly, rear light (pre April 2013) (optional)
038560	1	Rear light cluster, LH (April 2013 - on) Page 48
038561	1	Rear light cluster, RH (April 2013 - on) Page 48
004544	2	Tail light bulb, 12V 10W SE245 (April 2013 - on) Page 48
034849	2	Turn/hazard, side indicator (complete with bulb) Page 82
011487	2	. Capless bulb for side turn indicator Page 82
041494	1	Number plate bulb (bumper conversion)

<i>Part Number</i>	<i>Quantity</i>	<i>Description</i>
Electrical - Work Lamps, Beacons and Light Bars		
038769	AR	LED work lamp
047757	AR	Led work lamp
010304	1	Beacon 12 Volt
011496	AR	. Bulb, spare, LLB 448
022097	AR	. Lens, spare
010297	1	. Bracket, beacon 010304
024173	1	Beacon bar 33
028552	1	Light bar 20
032721	AR	Flashing beacon, LED, 12 Volt
036076*	1	. Attachment plate, LED beacon

Notes:-

* Only required when LED beacons are fitted in conjunction with rear directional arrow sign.

Labels and Decals

Assembly/Description

Page

Safety, Warning & Information Labels and Decals.	226
---	-----

<i>Item</i>	<i>Part Number</i>	<i>Quantity</i>	<i>Description</i>
Safety, Warning & Information Labels and Decals			
1	036222	1	Fuel grade (affixed to the fuel tank)
2	022384	2	Warning, hopper prop (affixed to both sides of vehicle)
3	022383	4	Warning, brush rotation (affixed to both sides of vehicle)
4	021061	1	Sound level (affixed to right rear of cab)
5	028760	1	Hydraulic oil
6	034549	1	Hydraulic oil level
7	034814	1	PM10 (specifies year of manufacture)
8	020028	1	Engine overheating
9	022725	1	Starting and stopping engine
10	014437	1	Headlamp
11	024384	1	Smoke
12	028623	1	First service
13	032477	1	Battery boost charging
14	035886	1	Cab lift
15	033483	1	Fuse and relay information
16	036359	1	Grab handle
17	036665	1	Max height
18	034292	1	Seat belt stowage
19	036223	1	Coolant grade
20	028910	1	Hazard, (hot coolant)
21	036170	AR	Warning, Isolate Battery (affixed to various places)
22	022849	2	Decal, "Scarab Minor" (affixed to both sides of vehicle)
23	042983	AR	Scarab Fayat logo, Black
NI	042984	AR	Scarab Fayat logo, White



Affixed inside cab



Labels and decals are not shown to scale. The wording on the labels may differ in some cases.

Street Wash Equipment

<i>Assembly/Description</i>	<i>Page</i>
Street Wash Spray Bar Arrangement	230
Street Wash Control Valve Assembly	232
Street Wash Diverting Control Valve Assembly	234
Street Wash Spray Bar Control Joystick	234
Street Wash Water Bag Arrangement	236

Item	Part Number	Quantity	Description
Street Wash Spray Bar Arrangement			
1	014977	1	Spray bar
2	014978	1	. Bracket, swivel
	011259	3	. . Bolt, M12 x 130mm
	011077	3	. . Nut, M12, Nyloc
3	010901	3	. Greasing point
4	013491	3	. Sleeve
5	013488	6	. Bush
NI	014979	1	. Mounting plate
NI	014981	2	. Ram pivot
NI	014982	2	. Clamp
NI	014983	2	. U clamp, 1½"
6	012973	1	. Ram, hydraulic, No 1
7	014984	1	. Bracket, pivot
8	013495	1	. Link, lower
9	013011	1	. Top link
10	014988	1	. Bracket, coupling
11	010112	9	. Nozzle body
12	020027	9	. . Spray jet
13	030951	9	. . . Nozzle cap
14	010990	2	. Hose, rubber, ¼" x 600mm, straight ends
15	001100	1	. Hose, rubber, ¼" x 460mm, straight and 90° ends
16	001023	1	. Hose, rubber, ⅜" x 710mm, straight ends
17	001220	1	. Hose, rubber, ⅜" x 410mm, straight and 90° ends
18	010067	6	. Pin 20mm x 50mm
19	011122	12	. Split pin, ⅜" x 1½"
NI	011171	3	. Elbow, swivel, M/F, ¼" BSP
20	012974	2	. Ram No2
21	012539	3	. Restrictor No5
22	011241	2	. Plug ¼" BSP
23	011152	5	. Seal, Dowty, ¼" BSP
24	012983	4	. Coupling, quick release ⅜" BSP
25	002008	4	. Adaptor, bulkhead, M/M, ⅜" BSP
NI	011199	8	. Adaptor, M/M, ¼" x ⅜" BSP
NI	011153	8	. . Seal, Dowty, ⅜" BSP
26	014998	4	. Dust cap
27	014999	4	. Dust cap
28	012253	4	. Antiluce, small
NI	011159	1	. Adaptor, M/M, ⅜" BSP
29	011257	1	. Ball valve ¼" BSP

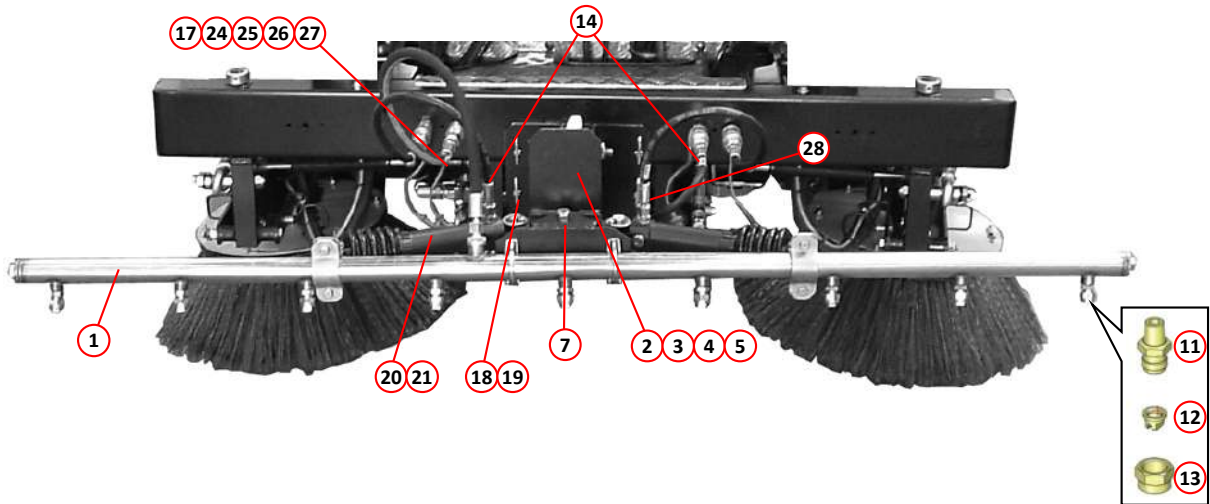
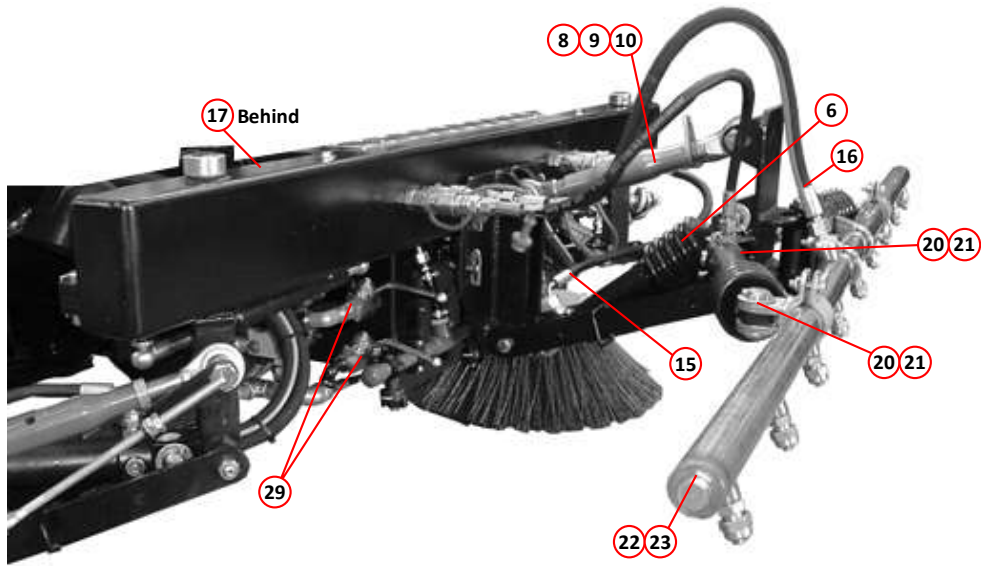

STREET WASH SPRAY BAR ARRANGEMENT

<i>Item</i>	<i>Part Number</i>	<i>Quantity</i>	<i>Description</i>
Street Wash Control Valve Assembly			
1	020380	1	Front mount hydraulics assembly (LH Drive)
1	020381	1	Front mount hydraulics assembly (RH Drive)
2	012582	2	. Valve solenoid, 12 Volt
3	012874	1	. Valve solenoid, 12 Volt
4	020116	1	. Mounting plate
	011006	4	. . Screw, socket cap head, M6 x 70mm
	011070	8	. . Nut, M6, Nyloc
	011014	4	. . Setscrew, M8 x 40mm
	011072	4	. . Nut, M8, Nyloc
	011003	4	. . Setscrew, M6 x 50mm
	000028	3	. . Screw, slotted round head, 2BA x $\frac{1}{2}$ " long
	011078	3	. . Nut, 2BA, Nyloc
	014025	12	. . Spacer
6	011152	2	. Seal, Dowty $\frac{1}{4}$ " BSP
7	011153	7	. Seal, Dowty $\frac{3}{8}$ " BSP
8	011158	2	. Adaptor, $\frac{1}{4}$ " BSP, M/M
9	011199	8	. Adaptor, M/M, $\frac{1}{4}$ " x $\frac{3}{8}$ " BSP
10	011171	4	. Elbow, Swivel, M/F, $\frac{1}{4}$ " BSP
11	002005	4	. Tee, M/M/M, $\frac{1}{4}$ " BSP
12	010958	2.0m	. Pipe, rubber, $\frac{3}{8}$ " bore
13	010516	4	. . Hose clip, worm drive, 11-16mm
14	010922	2	. Hose tail, $\frac{1}{4}$ " BSP x $\frac{3}{8}$ " hose
15	010921	1	. Hose tail, $\frac{3}{8}$ " BSP x $\frac{3}{8}$ " hose
16	010984	3	. Hose, rubber, $\frac{1}{4}$ " BSP x 2972mm, straight ends
17	011317	1	. Hose, rubber, $\frac{1}{4}$ " BSP x 295mm, straight ends
18	010982	1	. Hose, rubber, $\frac{1}{4}$ " BSP x 168mm, straight ends
19	001220	1	. Hose, rubber, $\frac{3}{8}$ " BSP x 410mm, straight and 90° ends
20	011214	3	. Adaptor, F/F, $\frac{3}{8}$ " BSP
21	023810	1	. Valve assembly 'E' Spool
NI	023569	1	. . Valve, control 'E' Spool
NI	021505	1	. . Cetop sub plate
NI	010112	1	. Nozzle, brass

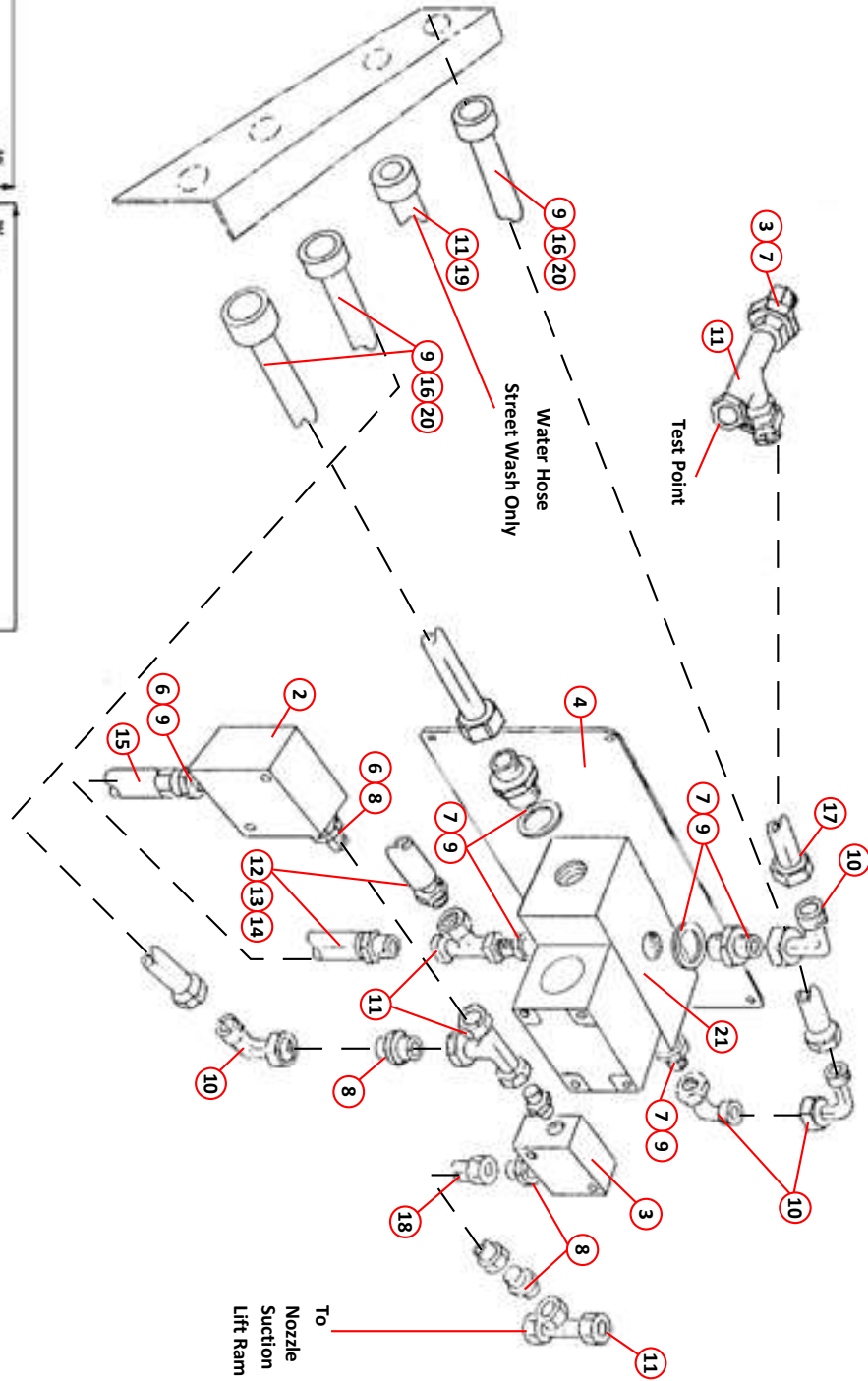
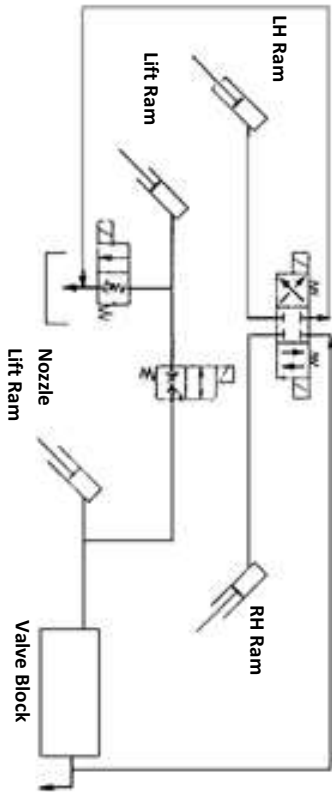

The Street Wash Control Valve Assembly is mounted on the side of the chassis.

CONTROL VALVE ASSEMBLY

<i>Item</i>	<i>Part Number</i>	<i>Quantity</i>	<i>Description</i>
Street Wash Diverting Control Valve Assembly			
1	021810	1	Bracket, mounting
2	038018	1	Cetop sub plate
3	000120	4	Bolt, M6 x 45mm
4	011090	8	Plain washer M6
5	011071	4	Nut, M6, Nyloc
6	023567	1	Valve, control, JA Spool-One S
7	000137	4	Screw, socket cap head, M5 x 50mm
8	011153	4	Seal, Dowty $\frac{3}{8}$ " BSP
9	011242	1	Plug $\frac{3}{8}$ " BSP
10	011167	1	Adaptor, M/M, $\frac{1}{2}$ " X $\frac{3}{8}$ " BSP
11	011234	1	Elbow, hose tail, $\frac{1}{2}$ " BSP to $\frac{5}{8}$ " bore
12	011159	2	Adaptor, M/M, $\frac{3}{8}$ " BSP
13	011172	2	Elbow, swivel, M/F, $\frac{3}{8}$ " BSP

<i>Item</i>	<i>Part Number</i>	<i>Quantity</i>	<i>Description</i>
Street Wash Spray Bar Control Joystick			
1	039654	1	Joystick
2	038791	1	. Joystick mounting pod

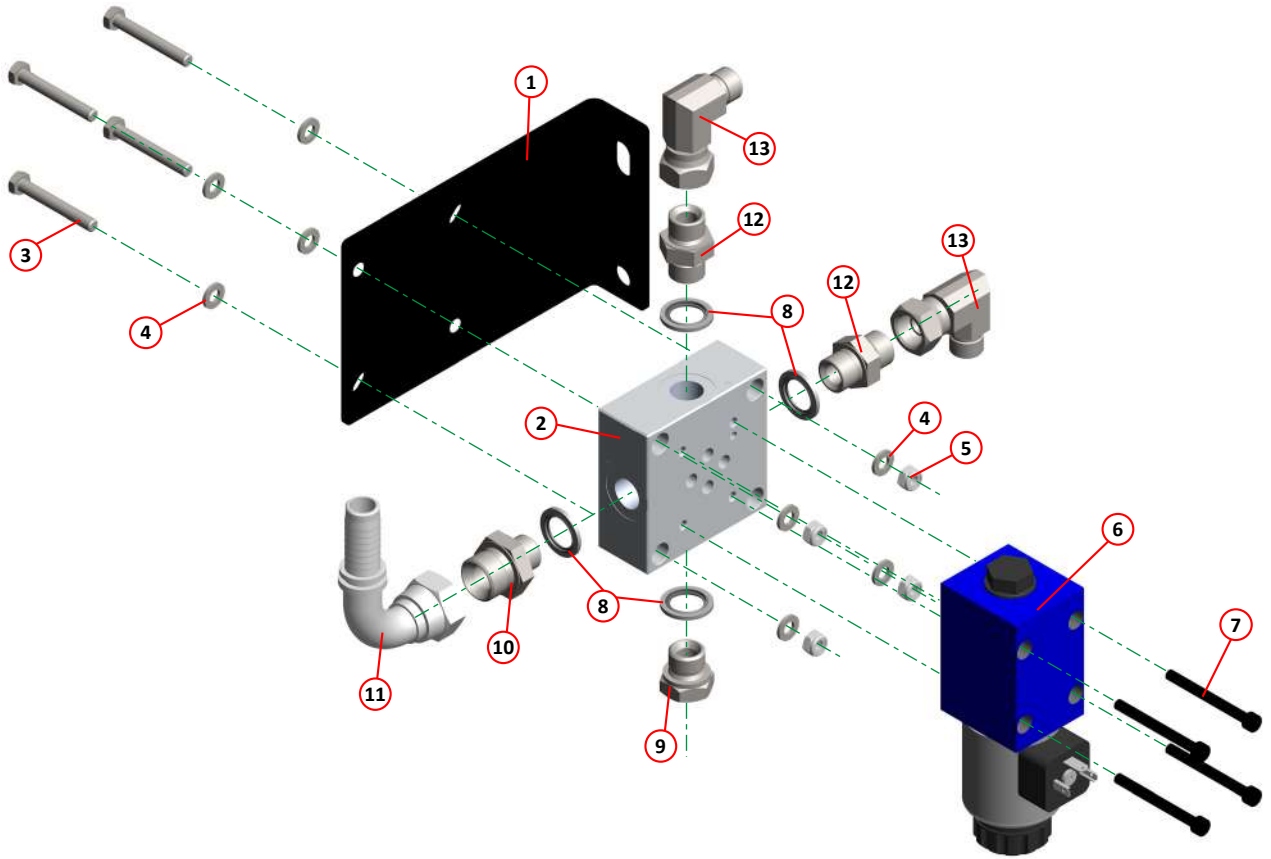

i The Street Wash Diverting Control Valve Assembly is mounted on the trunnion for the hopper lift ram.

STREET WASH DIVERTING CONTROL VALVE ASSEMBLY

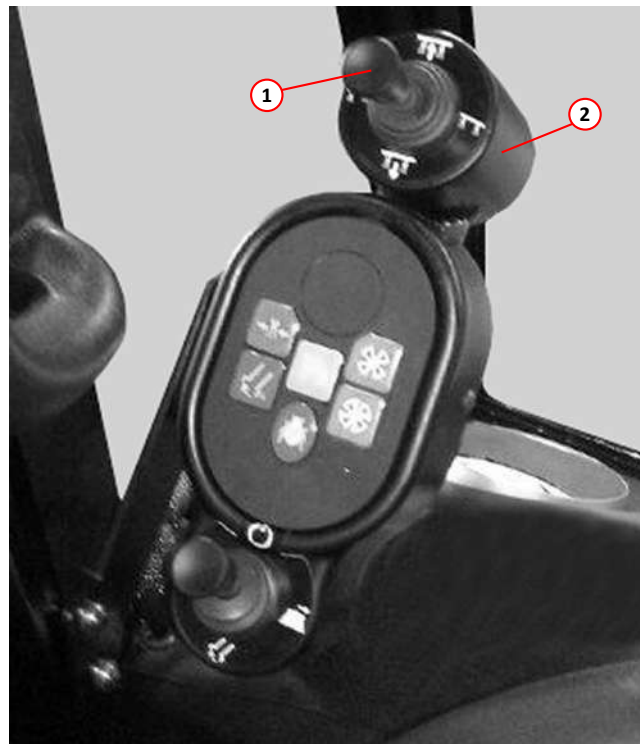

STREET WASH SPRAY BAR CONTROL JOYSTICK

<i>Item</i>	<i>Part Number</i>	<i>Quantity</i>	<i>Description</i>
Street Wash Water Bag Arrangement			
1	014859	1	Frame, lo-tip
1	014444	1	Frame, hi-tip
2	014865	1	. Water bag
2	014865	1	. Water bag, hi-tip
3	014864	4	. Hook
3	014417	2	. Hook, hi-tip
4	020313	2	. Hook
5	014749	1	. Hose coupling, female
6	014789	1	. Hose coupling, male
7	010518	5	. Clamp, worm drive, 25-35mm
8	010959	AR	. . Tube, rubber, 1" bore
9	002152	1	Valve, ball, 3-way
10	011161	3	. Adaptor, M/M, $\frac{3}{4}$ " BSP
11	011156	3	. Seal, Dowty, $\frac{3}{4}$ " BSP
12	021223	1	. Strainer, water filter
13	010931	2	. Hose tail, $\frac{3}{4}$ " BSP x 1" hose
14	012228	1	. Adaptor, M/F, $\frac{3}{4}$ " BSP
15	011174	1	. Elbow, swivel, F/F, $\frac{3}{4}$ " BSP

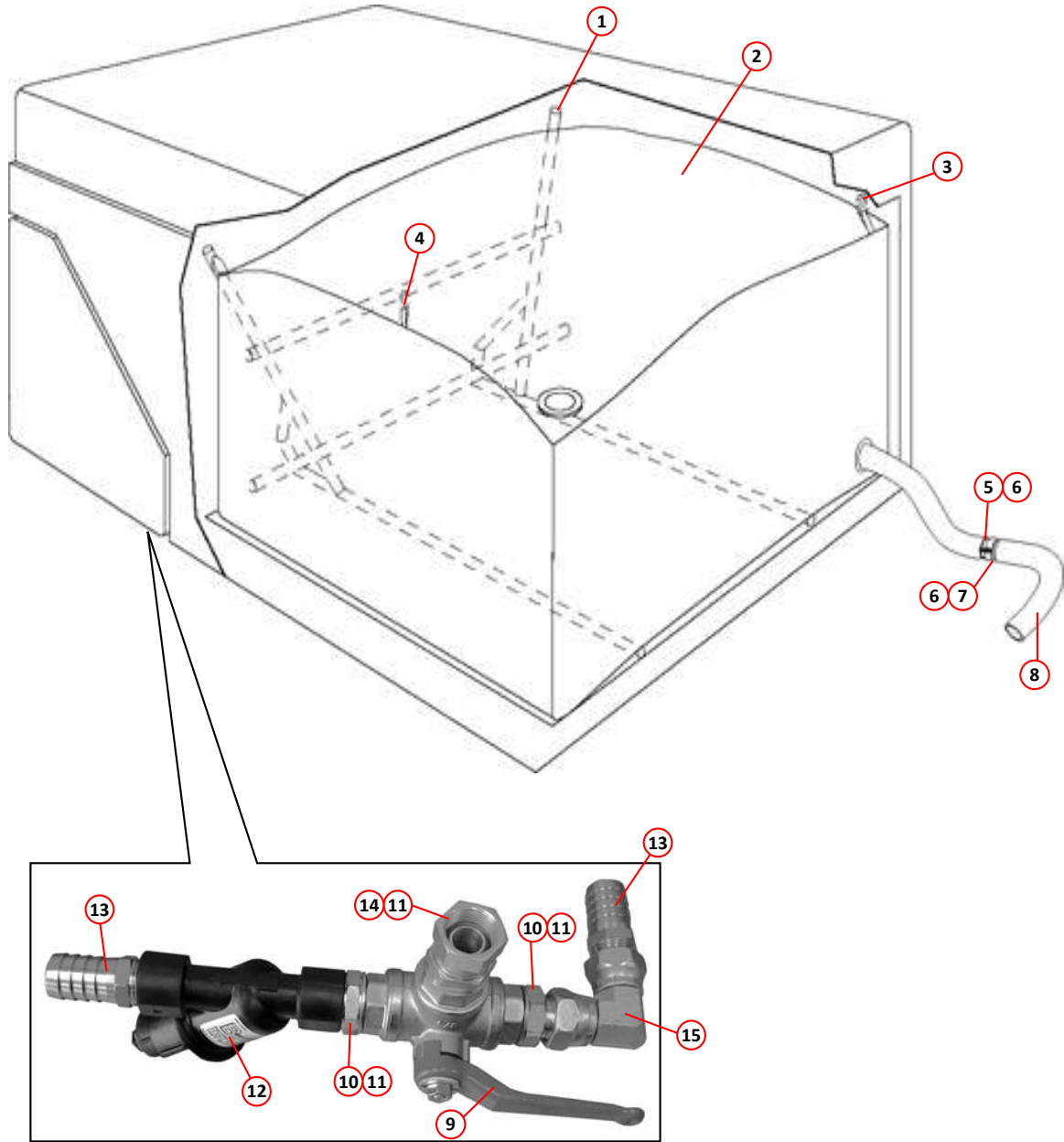

WATER BAG - LO-TIP ARRANGEMENT

