



# M65T SKID MOUNTED ROAD SWEEPER PARTS BOOK





# M65T Parts Book

Part No. SCAZ043469

Issue: 1.3.05 .....20th March 2024

To download the latest version visit [scarab-sweepers.com](http://scarab-sweepers.com)

Scarab Sweepers Limited  
Pattenden Lane - Marden - Kent TN12 9QD, UK  
T: +44 (0)1622 831 006  
E: [scarab@scarab.fayat.com](mailto:scarab@scarab.fayat.com)  
W: [scarab-sweepers.com](http://scarab-sweepers.com)  
Registered in England No. 18923459 - VAT No. GB 374 5002 68  
Registered Office: Pattenden Lane, Marden, Tonbridge, Kent TN12 9QD, UK

# Important Notice To Users

This manual is published by the Technical Publications Department of Scarab Sweepers Limited and every effort is made to ensure that the information it contains is correct at the time of publication. Due to a policy of continuous development, however, the Company reserves the right to alter the specification and to supply when so altered without reference to illustrations and descriptions in this manual.

Parts depicted or mentioned in this manual may or may not be fitted to your particular road sweeper due to various options that may or may not have been selected and does not therefore infer that the part should be fitted to your particular road sweeper or is missing. If in doubt then please contact the Scarab Parts Department for clarification.

It is imperative that the correct model is FULLY identified when procuring replacement parts for your Scarab Sweeper. To avoid unnecessary confusion and delays caused by incorrectly ordered parts, please refer to the Vehicle Serial Number (CE) Plate and take note of the vehicle's number.



**i** The Serial Number Plate is located on the left hand side of the subframe, below the hydraulics cabinet door.

The example shown here is for guidance only.

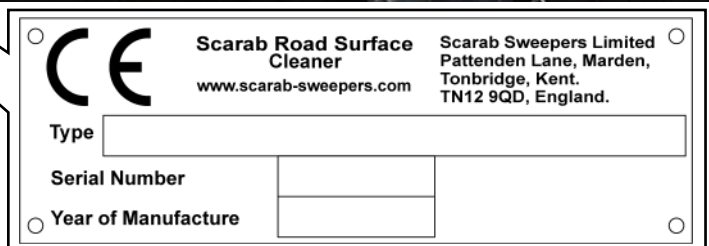

This information **MUST** accompany EVERY parts order to help ensure that the correct parts are supplied.



## Introduction

This parts book has been organised to facilitate ease of use when identifying and procuring replacement parts for the Scarab Sweeper.

The information content has been arranged in a logical manner by creating a number of separate sections, each dealing with a specific aspect or sub-system of the machine, complete with its own table of contents. Where relevant, cross-references from one section to another have been included to enable the user to quickly navigate to the information that gives the required level of detail.

## Using the Parts Lists

The breakdown structure within each parts list reflects the inter-relationship of the various components in an assembly.

The following lists the item, its part number, quantity and description and a page number (📄) if this part is cross referenced elsewhere in his manual. See Figure 1.

Item	Part No	Qty	Description	📄
①	037734	1	Bearing plate central brush (wide sweep)	53
②	038287	1	Central brush (wide sweep) bearing	
③	043059	1	Grease nipple M6 straight	
④	041527	1	Central brush (wide sweep) drive tube single sweep	58

Figure 1: Example of an parts in an assembly

## Item Numbers (Item)

Item numbers are used to cross-refer items from the parts lists to their associated illustrations and vice-versa, except for, attaching parts.

If the illustration of an item is superfluous or not illustrated, then the item number will be listed as not illustrated:- **NI**.

## Part Numbers (Part No)

Not every item will have a part number associated with it because it might be an assembly that is broken down into its components elsewhere or there might be different versions of that item described elsewhere.

If a part number is marked as **TBC** then this means **to be confirmed**. Please contact Scarab Part Department.

## Quantities (Qty)

When a parts quantity has been marked with **As Req** then this means **as required**, for example hose lengths may differ slightly due to the route taken, or you may have one or more of a given part then the quantity will be **as required** due to the quantity of said part that is fitted to a particular sweeper configuration.

## Description

A brief description of the part to further help with identification.

## Page (📄)

Use the number in this column to go to that page to get more information regarding this item/part.

## PDF Version

Includes bookmarks to each chapter and links to other sections from components that are also referenced elsewhere to make navigation throughout the manual easier. For example click a number in the Page (📄) column and it will take you to that page, or click an item in the table of contents to be taken to that page.

## Warranty Statement

1. Scarab Sweepers Limited (hereinafter referred to as the Company) warrants that (subject to the other provisions of the published Terms and Conditions of Sale - available upon request) upon delivery and for a period of 12 months from the date of actual delivery, or 2,000 running hours from the date of actual delivery whichever is sooner, the Goods correspond with their specification at the time of delivery, and will be free from defects in materials and workmanship.
2. The Company does not warrant the condition or quality of any used Goods supplied to the Customer, or other truck manufacturers' chassis cab content or to the auxiliary engine fitted in the Scarab Sweeper or to any other component not manufactured by the Company and any such warranty claims must be submitted to the manufacturer of that component, or their locally appointed agent.
3. The Company shall not be liable for a breach of any of the warranties in condition 1 unless the Customer gives written notice of the defect to the Company, and (if the defect is as a result of damage in transit) to the carrier, within 7 days of the time when the Customer discovers or ought to have discovered the defect.
4. The Company shall not be liable for a breach of any of the warranties in condition 1 if the Customer makes any further use of such Goods after giving such notice, the defect arises because the Customer failed to follow the Company's oral or written instructions as to the storage, installation, commissioning, use or maintenance of the Goods or (if there are none) good trade practice, or the Customer alters or repairs such Goods without the written consent of the Company, or uses non genuine parts to effect a repair.
5. The following consumable items listed are excluded from the Company warranty:
  - all fuel oils,
  - antifreeze,
  - all brush link pivots and bushes,
  - wander hoses, suction nozzles,
  - body inlet ducts, wearing plates,
  - high pressure water pump piston seals and valves,
  - door seals,
  - inlet seals,
  - batteries,
  - tyres,
  - all brushes,
  - lift cables,
  - rubber skirts,
  - suction nozzle wheels,
  - flap trunking,
  - deflectors,
  - screens flaps or blanking plates,
  - water pump diaphragm valves and water jets,
  - all filter strainers and elements,
  - windows,
  - glass mirrors,
  - light bulbs,
  - fuses,
  - brake lining pads,
  - auxiliary drive belts and any other part normally regarded as consumable.
6. Any parts replaced under the terms of this warranty will be covered by the unexpired portion of this warranty.
7. Subject to conditions 3 and 4, if any of the Goods do not conform with any of the warranties in condition 1 the Company shall at its option repair or replace such Goods (or the defective part) or refund the price of such Goods at the pro rata Contract rate provided that, if the Company so requests, the Customer shall, at the Customer's expense, remove the defective Goods or part of such Goods and return the Goods or the part of such Goods which is defective to the Company. Parts replaced under warranty will be delivered by the Company FOB port of exportation.
8. If the Company complies with the terms contained in this statement it shall have no further liability for a breach of any of the warranties in condition 1 in respect of such Goods.
9. No representative or agent of Scarab Sweepers Limited has the authority to add or to vary these Warranty Conditions except with the Company's official confirmation in writing from Scarab Sweepers Limited, head office in Marden Kent, England.

For further information, please refer to the Company's Terms & Conditions of Sale. In the event of conflict between this Warranty Statement and the Company's Terms & Conditions of Sale the latter will prevail.

# Table of contents

<i>Description</i>	<i>Page</i>
Foreword .....	3
Important Notice To Users .....	4
Introduction .....	5
Using the Parts Lists .....	5
Quantities (Qty) .....	5
Warranty Statement .....	6
<b>Table of contents .....</b>	<b>7</b>
<b>List of figures .....</b>	<b>17</b>
<b>Sweeping .....</b>	<b>25</b>
Left hand leg and side brush arrangement .....	26
Left hand leg and central brush mount .....	27
Left hand dummy leg and central brush mount .....	28
Left hand leg, side brush swing in/out cylinder mounting .....	29
Left hand leg, side brush front skirt .....	30
Left hand leg, side brush pipe clamps .....	31
Left hand side brush king post, swing in/out arrangement .....	32
Left hand side brush raise/lower arrangement .....	33
Left hand side brush water jet arrangement .....	34
Right hand leg and side brush arrangement .....	35
Right hand leg and central brush mount .....	36
Right hand dummy leg and central brush mount .....	37
Right hand leg, side brush swing in/out cylinder mounting .....	38
Right hand leg, side brush front skirt .....	39
Right hand leg, side brush pipe clamps .....	40
Right hand side brush, king post, swing in/out arrangement .....	41
Right hand side brush raise/lower arrangement .....	42
Right hand side brush water jet arrangement .....	43
Side brush and motor arrangement .....	44
Central brush (wide sweep) general arrangement .....	46
Central brush (wide sweep) mounting arrangement .....	47
Central brush (wide sweep) support, fixed slew .....	48
Central brush (wide sweep) dual sweep support slewing arrangement .....	49
Central brush (wide sweep) motor end arrangement .....	51
Central brush (wide sweep) bearing end arrangement .....	52
Central brush (wide sweep) motor arrangement .....	53
Central brush (wide sweep) bearing arrangement .....	54
Central brush (wide sweep) skirt arrangement .....	55
Central brush (wide sweep) cover and shaft arrangement .....	56
Central brush (wide sweep), brush and brush core arrangement .....	57
Central brush (wide sweep) extended, general arrangement .....	58
Central brush (wide sweep) extended, support .....	59
Central brush (wide sweep) extended, motor end arrangement .....	60
Central brush (wide sweep) extended, bearing end arrangement .....	61
Central brush (wide sweep) extended, motor arrangement .....	62
Central brush (wide sweep) extended, bearing arrangement .....	63

Central brush (wide sweep) extended, skirt arrangement	64
Central brush (wide sweep) extended cover and shaft	65
Central brush (wide sweep) extended, brush core and shaft	66
Auxiliary side brush, left hand, general arrangement	67
Auxiliary side brush, left hand, carrier	68
Auxiliary side brush, pneumatic cylinder, extend/retract	69
Auxiliary brush, left hand, swing in/out	70
Auxiliary brush, left hand, king post	71
Auxiliary brush, left hand, raise/lower linkage	72
Auxiliary brush, brush and motor assembly	73
Auxiliary brush, left hand, water jet arrangement	74
Auxiliary brush, bracket pipe/hose support	75
Auxiliary brush, speed control valve, brush	76
Auxiliary brush, work lamp	77
<b>Suction</b>	<b>79</b>
Left hand suction nozzle arrangement	81
Left hand suction nozzle hose	82
Left hand suction nozzle lift mechanism	83
Left hand suction nozzle skirt	84
Left hand suction nozzle frame	85
Left hand suction nozzle tilt pivot	86
Left hand suction nozzle tilt ram	87
Left hand suction nozzle tilt return springs	88
Left hand suction nozzle, flaps and skid plate	89
Left hand suction spigot, deflector and blanking arrangement	90
Suction spigot arrangement	91
Suction deflector tube	92
Left hand suction deflector tube, deflectors and auto blanking arrangement	93
Left hand deflector arrangement	94
Deflector swing plate arrangement	95
Left hand auto blanking arrangement	96
Left hand auto blanking	97
Right hand suction nozzle arrangement	98
Right hand suction nozzle hose	99
Right hand suction nozzle lift mechanism	100
Right hand suction nozzle skirt	101
Right hand suction nozzle frame	102
Right hand suction nozzle tilt pivot	103
Right hand suction nozzle tilt ram	104
Right hand suction nozzle tilt return springs	105
Right hand suction nozzle, flaps and skid plate	106
Right hand suction spigot, deflector and blanking arrangement	107
Suction spigot arrangement	108
Suction deflector tube	109
Right hand suction deflector tube, deflectors and auto blanking arrangement	110
Right hand deflector arrangement	111
Deflector swing plate arrangement	112
Right hand auto blanking arrangement	113
Right hand auto blanking	114
Left hand rear wander hose arrangement	115
Left hand rear wander hose, spigot sleeve	116
Left hand rear wander hose, boom	117
Left hand rear wander hose, nozzle stowage	118
Right hand rear wander hose arrangement	119

Right hand rear wander hose, spigot sleeve .....	120
Right hand rear wander hose, boom .....	121
Right hand rear wander hose, nozzle stowage .....	122
Left hand overhead boom suction nozzle arrangement .....	123
Left hand overhead boom carrier inspection hatch and deflector .....	124
Left hand overhead boom elbow and bearing .....	125
Left hand overhead boom suction tube, pivot and cuff .....	126
Left hand overhead boom suction tube, springs .....	127
Left hand overhead boom suction hose and cradle .....	128
Left hand overhead boom locker door components .....	129
Left hand overhead boom stowage components .....	130
Right hand overhead boom suction nozzle arrangement .....	131
Right hand overhead boom carrier access cover and deflector .....	132
Right hand overhead boom elbow and bearing .....	133
Right hand overhead boom suction tube, pivot and cuff .....	134
Right hand overhead boom suction tube, springs .....	135
Right hand overhead boom suction hose and cradle .....	136
Right hand overhead boom locker door components .....	137
Right hand overhead boom stowage components .....	138
Overhead boom extension tubes .....	139
Overhead boom water switch .....	140
PU lined suction components .....	141
<b>Suction fan .....</b>	<b>143</b>
Suction fan arrangement .....	144
Suction fan motor .....	145
Suction fan inlet cone and guard .....	146
Suction fan filter screen .....	147
<b>Hopper and body .....</b>	<b>149</b>
Hopper and body arrangement, external .....	150
Hopper and body arrangement, external .....	151
Hopper unit .....	152
Hopper cover .....	153
Hopper pivot pins and bushes .....	154
Hopper lift ram pivot .....	155
Hopper safety prop roller .....	156
Hopper locker covers .....	157
Hopper capping .....	158
Cover, wander hose duct .....	159
Blanking plugs on hopper rear panel with no rear wander hose .....	160
Hopper rear marker LEDs, hose and wiring clips .....	161
Fan inspection cover, external .....	162
Fan inspection cover, internal .....	163
Fan inspection cover with wash assist, internal .....	164
Locker door, right hand side .....	165
Locker door, left hand side .....	166
Hopper chutes .....	167
Pipework, hopper rear, left hand side .....	168
Pipework, hopper rear, right hand side .....	169
Hopper and body arrangement, internal .....	170
Hopper and body arrangement, internal .....	171
Suction fan inlet cone and guard .....	172

Suction fan filter screen .....	173
Safety latch, suction fan filter screen .....	174
Hopper blanking for single sweep .....	175
Hopper locker items, fan scraper, door safety prop, hydrant filler .....	176
Hydrant filler fittings and mountings .....	177
Rear door arrangement, overview .....	178
Rear door, with right hand inspection/access hatch .....	179
Rear door, with left hand inspection/access hatch .....	180
Hinges, rear door .....	181
Inspection/access hatch, right hand .....	182
Inspection/access hatch, left hand .....	183
Ladder and grab rail, rear door, right hand side .....	184
Ladder and grab rail, rear door, left hand side .....	185
Lay flat hose, rear door, hopper drain .....	186
Rear door open/close/locking arrangement .....	187
Hinge, rear door ram .....	188
Ram, rear door open/close/lock .....	189
Locking bar, rear door .....	190
Locking cam, rear door .....	191
Locking wear plates, rear door .....	192
Rear camera mountings .....	193
Direction sign, rear door mounted .....	194

**Water ..... 195**

Water system layout .....	196
Water tank .....	198
Water tank anti-vibration mountings .....	199
Water tank mounting support plates .....	200
Water level sight tube, water tank .....	201
Lid, water tank .....	202
Fittings, water tank, front .....	203
Drain, water tank .....	204
Drain, water tank, when auxiliary water tank fitted .....	205
Fittings, water tank, rear .....	206
Auxiliary water tank, 650 litre (172 US gallons), mounting location .....	207
Auxiliary water tank, 650 litre (172 US gallons) .....	208
Auxiliary water tank, lower mounting brackets .....	209
Auxiliary water tank, upper mounting braces .....	210
Auxiliary water tank, filler lid .....	211
Auxiliary water tank, sight tube .....	212
Auxiliary water tank, valve fittings .....	213
Water strainer, low pressure .....	214
Water pump, twin diaphragm, low pressure, mounting .....	215
Water pump, twin diaphragm, low pressure, fittings .....	216
Water pump, twin diaphragm, low pressure, components .....	217
Water valves, location .....	218
Water valves, 2-way, mounting .....	219
Water valves, 3-way, mounting .....	220
Water valves, 4-way, mounting .....	221
Water valves, 5-way, mounting .....	222
Water valves, 6-way, mounting .....	223
Water valve components .....	224
Water spray nozzle, twin, left hand side brush .....	225
Water spray nozzle, twin, right hand side brush .....	226

Water spray nozzles, suction nozzle box .....	227
Water spray nozzles, suction spigot .....	228
Front spray bar, low pressure .....	229
Water nozzle, overhead boom suction tube .....	230
High pressure water sy .....	231
Water strainer, high pressure .....	231
Water pump, high pressure 30 LPM, mounting, motor and coupling .....	232
Water pump, high pressure 30 LPM, feed, output and return fittings .....	233
Water pump, high pressure 30 LPM, drainage fittings .....	234
Water pump, high pressure 30 LPM, seal kits .....	235
Front spray bar, combined high pressure/low pressure .....	236
Shut off valve and low pressure non return valve, combined front spray bar .....	237
Hose reel and mounting .....	238
Hand lance and mounting .....	239
Spray bar, high pressure, front of suction nozzle, mounting .....	240
Spray bar, high pressure, front of suction nozzle, water feed and shut off valve .....	241
Spray bar, high pressure, rear of suction nozzle, mounting .....	242
Spray bar, high pressure, rear of suction nozzle, water feed and shut off valve .....	243
Spray bar, high pressure, central brush (wide sweep), mounting, water feed and shut off valve .....	244
Fan wash assist .....	245
<b>Hydraulics .....</b>	<b>247</b>
Combined intercooler/radiator/hydraulic oil cooler .....	248
Hydraulic tank and fittings .....	249
Hydraulic tank and fittings .....	250
Hydraulic suction manifold .....	251
Fan pump and gear pumps, general arrangement .....	252
Fan pump and fittings .....	253
Gear pumps and fittings .....	254
Flow control valves and fittings .....	255
Hydraulic high pressure oil filters and fittings .....	256
Suction fan and suction nozzle tilt control circuits, general arrangement .....	257
Suction fan control circuit .....	258
Suction fan control circuit .....	259
Suction nozzle tilt control valve .....	260
Suction fan motor .....	261
Valve blocks, arrangement .....	262
Main valve block, coils, solenoids, check valves and plugs .....	263
Main valve block, fittings .....	264
Main valve block, pipes and hoses .....	265
Options valve block, coils and solenoids .....	266
Options valve block, fittings, pipes and hoses .....	267
Hopper control valve, coils and solenoids .....	268
Hopper control valve, fittings and hoses .....	269
Hand pump, hopper and rear door .....	270
Ram, dual stage, hopper lift .....	271
Ram, rear door open/close/locking .....	272
Ram, side brush lift .....	273
Ram, suction nozzle tilt .....	274
Motor, side brush .....	275
Motor, central brush (wide sweep) .....	276
Motor, suction fan .....	277



Motor, low pressure water pump .....	278
Motor, high pressure water pump .....	279
Hoses .....	280
Pipes .....	281
Steel pipes, brushes, left hand sweep .....	281
Steel pipes, brushes, left hand sweep .....	282
Clamp blocks, steel pipes, brushes, left hand sweep .....	283
Steel pipes, brushes, right hand sweep .....	284
Clamp blocks, steel pipes, brushes, left hand sweep .....	285
Steel pipes, options block .....	286
Clamp blocks, steel pipes, options block .....	287
Steel pipes, suction fan and rear door open/close/lock .....	288
Clamp blocks, steel pipes, suction fan and rear door open/close/lock .....	289
<b>Pneumatics .....</b>	<b>291</b>
Pneumatic control valves, pre August 2017, 24v system .....	292
Pneumatic control block and valves, high temperature .....	294
5/2 HT spring valve body and 15mm HT solenoid valve .....	296
5/2 HT spring valve body .....	297
15mm HT solenoid valve, .....	298
5/2 pilot/pilot HT valve .....	299
5/3 pilot/pilot HT valve .....	300
Valve, OR gate .....	301
Seals and gaskets .....	302
Breather and relief valves .....	303
Pneumatic regulator and filter .....	304
Pressure regulator valve, central brush (wide sweep) .....	305
Pressure regulator valve side brush and switches for brush pressure (cab mounted) .....	306
Central brush (wide sweep), raise/lower/pressure .....	307
Central brush (wide sweep), slewing .....	308
Suction nozzle, raise/lower .....	309
Side brush, swing in/out .....	310
Side brush, pressure .....	311
Auto blanking .....	312
Auxiliary brush, raise/lower .....	313
Auxiliary brush, left hand, swing in/out .....	314
Auxiliary brush, extend/retract .....	315
Hopper safety prop, kicker .....	316
<b>Electrical .....</b>	<b>317</b>
Electrical components in the cab .....	318
Main control panel .....	318
Auxiliary control panel (door pod) .....	319
Hopper controller remote .....	320
Display screen, operator, programmed .....	320
CR2012 cabinet module, node .....	320
Beacon switch .....	321
Sounder, main control panel .....	321
Camera monitor .....	321
Camera splitter .....	322
Fuses and relays, cab .....	322
Node cabinet .....	323

- Nodes ..... 324
- Relays ..... 324
- Power connection link ..... 324
- Power post ..... 325
- Switch, gantry work light ..... 325
- Fuses, Nodes ..... 326
- Battery junction box ..... 327
- Lights, lamps and cameras ..... 328
  - Work light ..... 328
  - LED marker rear light ..... 328
  - Beacon ..... 328
  - LED beacon ..... 329
  - Cameras ..... 329
- Wiring looms and cables ..... 330
- Switches ..... 330
- Sensors ..... 331
- Fuses ..... 331
- Relays ..... 331

**Engine frame and subframe ..... 333**

- Engine frame ..... 335
  - Engine frame and covers general arrangement ..... 335
  - Covers, engine frame ..... 336
  - Door, left hand side, engine frame ..... 337
  - Door, right hand side, engine frame ..... 338
  - Hydraulic oil tank mounting, engine frame ..... 339
    - Hydraulic tank and fittings ..... 340
    - Hydraulic tank and fittings ..... 341
  - Node and pneumatics cabinet mounting, engine frame ..... 342
    - Node and pneumatics cabinet ..... 343
    - Node and pneumatics cabinet ..... 344
    - Node and pneumatics cabinet ..... 345
  - Fuel tank mounting, engine frame ..... 346
    - Fuel tank, fittings ..... 347
  - Combined intercooler/radiator/hydraulic oil cooler mounting, engine frame ..... 348
  - Safety bar, engine frame ..... 349
  - Battery junction box and hydraulic oil filters mounting, engine frame ..... 350
  - Fuel filters and fuel pump mounting, engine frame ..... 351
  - Hopper raised sensor, engine frame ..... 352
  - Work light, engine frame ..... 353
  - Exhaust stack mounting, engine frame ..... 354
  - Air intake stack mounting, engine frame ..... 355
  - Flow control valve block and hydraulic manifold mountings, engine frame ..... 356
  - Engine cradle and mounts, rear, engine frame ..... 357
  - Engine cradle and mounts, front, engine frame ..... 358
  - Expansion tank mounting, engine frame ..... 359
  - ECU cover mounting, engine frame ..... 360
  - Hydraulic cabinet door fittings, engine frame ..... 361
  - Hydraulic cabinet valve block fittings, engine frame ..... 362
  - End panels, engine frame ..... 363
  - Engine frame ..... 364
  - Subframe general arrangement ..... 365
    - Subframe ..... 366

Subframe and pipe, hose and wiring support brackets .....	367
Hopper safety prop .....	368
Floor plate, subframe and engine frame .....	369
Subframe hopper lift ram mounting .....	370
Access ladder and grab handle, subframe and engine frame .....	371
Subframe to engine frame mounting .....	372
Subframe to chassis mounting general arrangement .....	373
Subframe to chassis mountings, DAF .....	374
Subframe to chassis mountings, position 1, DAF .....	375
Subframe to chassis mountings, position 2, DAF .....	376
Subframe to chassis mountings, position 3, DAF .....	377
Subframe to chassis mountings, position 4, DAF .....	378
Subframe to chassis mountings lateral support, left side, DAF .....	379
Subframe to chassis mountings lateral support, right side, DAF .....	380
Subframe to chassis mountings, SCANIA .....	381
Subframe to chassis mountings, position 1, SCANIA .....	382
Subframe to chassis mountings, position 2, SCANIA .....	383
Subframe to chassis mountings, position 3, SCANIA .....	384
Subframe to chassis mountings, position 4, SCANIA .....	385
Subframe to chassis mountings lateral support, left side, SCANIA .....	386
Subframe to chassis mountings lateral support, right side, SCANIA .....	387
Subframe to chassis mountings, VOLVO .....	388
Subframe to chassis mountings, position 1, VOLVO .....	389
Subframe to chassis mountings, position 2, VOLVO .....	390
Subframe to chassis mountings, position 3, VOLVO .....	391
Subframe to chassis mountings, position 4, VOLVO .....	392
Subframe to chassis mountings lateral support, left side, VOLVO .....	393
Subframe to chassis mountings lateral support, right side, VOLVO .....	394
Subframe to chassis mountings, IVECO .....	395
Subframe to chassis mountings, position 1, IVECO .....	396
Subframe to chassis mountings, position 2, IVECO .....	397
Subframe to chassis mountings, position 3, IVECO .....	398
Subframe to chassis mountings, position 4, IVECO .....	399
Subframe to chassis mountings lateral support, left side, IVECO .....	400
Subframe to chassis mountings lateral support, right side, IVECO .....	401
Subframe to chassis mountings, Mercedes .....	402
Subframe to chassis mountings, position 1, Mercedes .....	403
Subframe to chassis mountings, position 2, Mercedes .....	404
Subframe to chassis mountings, position 3, Mercedes .....	405
Subframe to chassis mountings, position 4, Mercedes .....	406
Subframe to chassis mountings lateral support, left side, Mercedes .....	407
Subframe to chassis mountings lateral support, right side, Mercedes .....	408
Subframe to chassis mountings MAN 18.290 .....	409
Subframe to chassis mountings, position 1, MAN .....	410
Subframe to chassis mountings, position 2, MAN .....	411
Subframe to chassis mountings, position 3, MAN .....	412
Subframe to chassis mountings, position 4, MAN .....	413
Subframe to chassis mountings lateral support, left side, MAN .....	414
Subframe to chassis mountings lateral support, right side, MAN .....	415
Subframe to chassis mountings, Freightliner M2 106 .....	416
Subframe to chassis mountings, position 1, Freightliner .....	417
Subframe to chassis mountings, position 2, Freightliner .....	418
Subframe to chassis mountings, position 3, Freightliner .....	419
Subframe to chassis mountings, position 4, Freightliner .....	420

Subframe to chassis mountings lateral support, left side, Freightliner .....421  
 Subframe to chassis mountings lateral support, right side, Freightliner .....422

**Engine ..... 423**

Engine ..... 424  
 General layout, engine ..... 424  
 Engine cradles and mounts ..... 425  
 Engine mountings ..... 426  
 Cooling fan, engine ..... 427  
 Ancillary belt, alternator and engine speed sensors, engine ..... 428  
 Starter motor, coolant temperature, rail pressure and charge air pressure/temp sensors, engine ..... 429  
 Oil pressure sensor, engine ..... 430  
 Fuel injectors and glow plugs, engine ..... 431  
 DUETZ TCD 3.6 L4 engine ..... 432  
 Fuel pump and filters, engine ..... 433  
 Exhaust stack, engine ..... 434  
 Air intake stack, engine ..... 435  
 Expansion tank, engine ..... 436  
 Combined intercooler/radiator/hydraulic oil cooler, engine ..... 437  
 Other components, engine ..... 438  
 Centaflex coupling and fan pump housing plate, engine ..... 439

**Cab components ..... 441**

Cab components ..... 442  
 General layout, cab components ..... 442  
 Main control panel and operator screen mountings, cab components ..... 443  
 Main control panel and operator screen mountings, cab components, Freightliner M2106 DS ..... 444  
 Auxiliary control panel (door pod) mountings, cab components ..... 445  
 Brush pressure controls, cab components ..... 446  
 Hopper controller remote, mountings, cab components ..... 447  
 CR2012 cabinet module, slave node, mountings, cab components ..... 448  
 Other components, cab components ..... 449

**Labels, decals and badges ..... 451**

Labels, decals and badges ..... 452  
 Warning labels ..... 452  
 Information labels ..... 453  
 Decals and badges ..... 454

**Multi-lingual glossary ..... 455**

Rear Cover ..... 495



# List of figures

<i>Description</i>	<i>Page</i>
1: Example of an parts in an assembly . . . . .	5
2: Left hand leg and side brush arrangement . . . . .	26
3: Left hand leg and central brush mount . . . . .	27
4: Left hand dummy leg and central brush mount . . . . .	28
5: Left hand leg, side brush swing in/out cylinder mounting arm . . . . .	29
6: Left hand leg, side brush front skirt . . . . .	30
7: Left hand leg, side brush pipe clamps . . . . .	31
8: Left hand side brush king, swing in/out post arrangement . . . . .	32
9: Left hand side brush raise/lower arrangement . . . . .	33
10: Left hand side brush water jet arrangement . . . . .	34
11: Right hand leg and side brush arrangement . . . . .	35
12: Right hand leg and central brush mount . . . . .	36
13: Right hand dummy leg and central brush mount . . . . .	37
14: Right hand leg, side brush swing in/out cylinder mounting arm . . . . .	38
15: Right hand leg, side brush front skirt . . . . .	39
16: Right hand leg, side brush pipe clamps . . . . .	40
17: Right hand side brush, king post, swing in/out arrangement . . . . .	41
18: Right hand side brush raise/lower arrangement . . . . .	42
19: Right hand side brush water jet arrangement . . . . .	43
20: Side brush and motor arrangement . . . . .	44
21: Central brush (wide sweep) general arrangement . . . . .	46
22: Central brush (wide sweep) mounting arrangement . . . . .	47
23: Central brush (wide sweep) support, fixed slew . . . . .	48
24: Central brush (wide sweep) dual sweep support slewing arrangement . . . . .	50
25: Central brush (wide sweep) motor end arrangement . . . . .	51
26: Central brush (wide sweep) bearing end arrangement . . . . .	52
27: Central brush (wide sweep) motor arrangement . . . . .	53
28: Central brush (wide sweep) bearing arrangement . . . . .	54
29: Central brush (wide sweep) skirt arrangement . . . . .	55
30: Central brush (wide sweep) cover and shaft arrangement . . . . .	56
31: Central brush (wide sweep), brush and brush core arrangement . . . . .	57
32: Central brush (wide sweep extended), general arrangement . . . . .	58
33: Central brush (wide sweep) Extended, support . . . . .	59
34: Central brush (wide sweep) extended, motor end arrangement . . . . .	60
35: Central brush (wide sweep) extended, bearing end arrangement . . . . .	61
36: Central brush (wide sweep) extended, motor arrangement . . . . .	62
37: Central brush (wide sweep) extended, bearing arrangement . . . . .	63
38: Central brush (wide sweep) extended, skirt arrangement . . . . .	64
39: Central brush (wide sweep) extended cover and shaft . . . . .	65
40: Central brush (wide sweep) extended, brush core and shaft . . . . .	66
41: Auxiliary side brush, left hand, general arrangement . . . . .	67
42: Auxiliary side brush, left hand, carrier . . . . .	68
43: Auxiliary side brush, pneumatic cylinder, extend retract . . . . .	69
44: Auxiliary brush, left hand, swing in/out . . . . .	70
45: Auxiliary brush, left hand, king post . . . . .	71
46: Auxiliary brush, left hand, raise/lower linkage . . . . .	72
47: Auxiliary brush, brush and motor assembly . . . . .	73
48: Auxiliary brush, left hand, water jet arrangement . . . . .	74
49: Auxiliary brush, bracket pipe/hose support . . . . .	75
50: Auxiliary brush, speed control valve, brush . . . . .	76
51: Auxiliary brush, work lamp . . . . .	77
52: Left hand suction nozzle arrangement . . . . .	81
53: Left hand suction nozzle hose . . . . .	82

54: Left hand suction nozzle lift mechanism	83
55: Left hand suction nozzle skirt	84
56: Left hand suction nozzle frame	85
57: Left hand suction nozzle tilt pivot	86
58: Left hand suction nozzle tilt ram	87
59: Left hand suction nozzle tilt return springs	88
60: Left hand suction nozzle, flaps and skid plate	89
61: Left hand suction spigot, deflector and blanking arrangement	90
62: Suction spigot arrangement	91
63: Suction deflector tube	92
64: Left hand suction deflector tube, deflectors and auto blanking arrangement	93
65: Left hand deflector arrangement	94
66: Deflector swing plate arrangement	95
67: Left hand auto blanking arrangement	96
68: Right hand auto blanking	97
68: Left hand auto blanking	97
69: Right hand suction nozzle arrangement	98
70: Right hand suction nozzle hose	99
71: Right hand suction nozzle lift mechanism	100
72: Right hand suction nozzle skirt	101
73: Right hand suction nozzle frame	102
74: Right hand suction nozzle tilt pivot	103
75: Right hand suction nozzle tilt ram	104
76: Right hand suction nozzle tilt return springs	105
77: Right hand suction nozzle, flaps and skid plate	106
78: Right hand suction spigot, deflector and blanking arrangement	107
79: Suction spigot arrangement	108
80: Suction deflector tube	109
81: Right hand suction deflector tube, deflectors and auto blanking arrangement	110
82: Left hand deflector arrangement	111
83: Deflector swing plate arrangement	112
84: Right hand auto blanking arrangement	113
85: Right hand auto blanking	114
85: Right hand auto blanking	114
86: Left hand rear wander hose arrangement	115
87: Left hand rear wander hose, spigot sleeve	116
88: Left hand rear wander hose, boom	117
89: Left hand rear wander hose, nozzle stowage	118
90: Right hand rear wander hose arrangement	119
91: Right hand rear wander hose, spigot sleeve	120
92: Right hand rear wander hose, boom	121
93: Right hand rear wander hose, nozzle stowage	122
94: Left hand overhead suction nozzle arrangement	123
95: Left hand overhead boom carrier inspection hatch and deflector	124
96: Left hand overhead boom elbow and bearing	125
97: Left hand overhead boom suction tube, pivot and cuff	126
98: Left hand overhead boom suction tube, springs and elbow	127
99: Left hand overhead boom suction hose and cradle	128
100: Left hand overhead boom locker door components	129
101: Left hand overhead boom stowage components	130
102: Right hand overhead suction nozzle arrangement	131
103: Right hand overhead boom carrier inspection hatch and deflector	132
104: Right hand overhead boom elbow and bearing	133
105: Right hand overhead boom suction tube, pivot and cuff	134
106: Right hand overhead boom suction tube, springs and elbow	135
107: Right hand overhead boom suction hose and cradle	136
108: Right hand overhead boom locker door components	137



109: Right hand overhead boom stowage components	138
110: Overhead boom extension tubes	139
111: Overhead boom water switch	140
112: PU lined suction components	141
113: Suction fan arrangement	144
114: Suction fan motor	145
115: Suction fan motor	146
116: Suction fan filter screen	147
117: Hopper and body arrangement, external	150
118: Hopper and body arrangement, external	151
119: Hopper unit	152
120: Hopper cover	153
121: Hopper pivot pins and bushes	154
122: Hopper lift ram pivot	155
123: Hopper safety prop roller	156
124: Hopper locker covers	157
125: Hopper capping	158
126: Cover, wander hose duct	159
127: Blanking plugs on hopper with no rear wander hose	160
128: Hopper rear marker LEDs, hose and wiring clips	161
129: Fan inspection cover, external	162
130: Fan inspection cover, internal	163
131: Fan inspection cover with wash assist, internal	164
132: Locker door, right hand side	165
133: Locker door, left hand side	166
134: Hopper chutes	167
135: Pipework, hopper rear, left hand side	168
136: Pipework, hopper rear, right hand side	169
137: Hopper and body arrangement, internal	170
138: Hopper and body arrangement, internal	171
139: Suction fan motor	172
140: Suction fan filter screen	173
141: Safety latch, suction fan filter screen	174
142: Hopper blanking for single sweep	175
143: Hopper locker items, fan scraper, door safety prop, hydrant filler	176
144: Hydrant filler fittings and mountings	177
145: Rear door arrangement, overview	178
146: Rear door, with right hand inspection/access hatch	179
147: Rear door, with left hand inspection/access hatch	180
148: Hinges, rear door	181
149: Inspection/access hatch, right hand	182
150: Inspection/access hatch, left hand	183
151: Ladder and grab rail, rear door, right hand side	184
152: Ladder and grab rail, rear door, left hand side	185
153: Lay flat hose, rear door, hopper drain	186
154: Rear door open/close/locking arrangement	187
155: Hinge, rear door ram	188
156: Ram, rear door open/close/lock	189
157: Locking bar, rear door	190
158: Locking cam, rear door	191
159: Locking wear plates, rear door	192
160: Rear camera mountings	193
161: Direction sign, rear door mounted	194
162: Water system layout	196
163: Water tank	198
164: Water tank anti-vibration mountings	199
165: Water tank mounting support plates	200

166: Water level sight tube, water tank .....	201
167: Lid, water tank .....	202
168: Fittings, water tank, front .....	203
169: Drain, water tank .....	204
170: Drain, water tank, when auxiliary water tank fitted .....	205
171: Fittings, water tank, rear .....	206
172: Auxiliary water tank, 650 litres (172 US gallons), mounting location .....	207
173: Auxiliary water tank, 650 litres (172 US gallons) .....	208
174: Auxiliary water tank, lower mounting brackets .....	209
175: Auxiliary water tank, upper mounting braces .....	210
176: Auxiliary water tank, filler lid .....	211
177: Auxiliary water tank, sight tube .....	212
178: Auxiliary water tank, valve fittings .....	213
179: Water strainer, low pressure .....	214
180: Water pump, twin diaphragm, low pressure, mounting .....	215
181: Water pump, twin diaphragm, low pressure, fittings .....	216
182: Water pump, low pressure, components .....	217
183: Water valves, location .....	218
184: Water valves, 2-way, mounting .....	219
185: Water valves, 3-way, mounting .....	220
186: Water valves, 4-way, mounting .....	221
187: Water valves, 5-way, mounting .....	222
188: Water valves, 6-way, mounting .....	223
189: Water valve components .....	224
190: Water spray nozzle, twin, left hand side brush .....	225
191: Water spray nozzle, twin, right hand side brush .....	226
192: Water spray nozzles, suction nozzle box .....	227
193: Water spray nozzles, suction spigot .....	228
194: Front spray bar, low pressure .....	229
195: Water nozzle, overhead boom suction tube .....	230
196: Water strainer, high pressure .....	231
197: Water pump, high pressure 30 LPM, mounting, motor and coupling .....	232
198: Water pump, high pressure 30 LPM, feed, output and return fittings .....	233
199: Water pump, high pressure 30 LPM, drainage fittings .....	234
200: Water pump, high pressure 30 LPM, seal kits .....	235
201: Front spray bar, combined high pressure/low pressure .....	236
202: Shut off valve and low pressure non return valve, combined front spray bar .....	237
203: Hose reel and mounting .....	238
204: Hand lance and mounting .....	239
205: Spray bar, high pressure, front of suction nozzle, mounting .....	240
206: Spray bar, high pressure, front of suction nozzle, water feed and shut of valve .....	241
207: Spray bar, high pressure, rear of suction nozzle, mounting .....	242
208: Spray bar, high pressure, rear of suction nozzle, water feed and shut off valve .....	243
209: Spray bar, high pressure, central brush (wide sweep), mounting, water feed and shut off valve .....	244
210: Fan wash assist .....	245
211: Combined intercooler/radiator/hydraulic oil cooler .....	248
212: Hydraulic tank and fittings .....	249
213: Hydraulic tank and fittings .....	250
214: Hydraulic suction manifold .....	251
215: Fan pump and gear pumps, general arrangement .....	252
216: Fan pump and fittings .....	253
217: Gear pumps and fittings .....	254
218: Flow control valves and fittings .....	255
219: Hydraulic high pressure oil filters and fittings .....	256
220: Suction fan and suction nozzle tilt control circuits, general arrangement .....	257
221: Suction fan control circuit .....	258
222: Suction fan control circuit .....	259

223: Suction nozzle tilt control valve	260
224: Suction fan motor	261
225: Valve blocks, arrangement	262
226: Main valve block, coils, solenoids, check vales and plugs	263
227: Main valve block, fittings	264
228: Main valve block, pipes and hoses	265
229: Options valve block, coils and solenoids	266
230: Options valve block, fittings, pipes and hoses	267
231: Hopper control valve, coils and solenoids	268
232: Hopper control valve	269
233: Hand pump, hopper and rear door	270
234: Ram, dual stage, hopper lift	271
235: Ram, rear door open/close/locking	272
236: Ram, side brush lift	273
237: Ram, suction nozzle tilt	274
238: Motor, side brush	275
239: Motor, central brush (wide sweep)	276
240: Motor, suction fan	277
241: Motor, low pressure water pump	278
242: Motor, high pressure water pump	279
243: Steel pipes, brushes, left hand sweep	281
244: Steel pipes, brushes, left hand sweep	282
245: Clamp blocks, steel pipes, brushes, right hand sweep	283
246: Steel pipes, brushes, right hand sweep	284
247: Clamp blocks, steel pipes, brushes, left hand sweep	285
248: Steel pipes, options block	286
249: Clamp blocks, steel pipes, options block	287
250: Steel pipes, suction fan and rear door open/close/lock	288
251: Clamp blocks, steel pipes, suction fan and rear door open/close/lock	289
252: Pneumatic control valves, pre August 2017, 24v system	292
253: Pneumatic control block and valves, high temperature	294
254: 5/2 HT spring valve body and 15mm HT solenoid valve	296
255: 5/2 HT spring valve body	297
256: 15mm HT solenoid valve	298
257: 5/2 pilot/pilot HT valve	299
258: 5/2 pilot/pilot HT valve	300
259: Valve, OR gate, high temperature	301
260: Seals and gaskets	302
261: Breather and relief valves	303
262: Pneumatic regulator and filter	304
263: Pressure regulator valve, central brush (wide sweep)	305
264: Pressure regulator valve side brush and switches for brush pressure (cab mounted)	306
265: Central brush (wide sweep), raise/lower/pressure	307
266: Central brush (wide sweep), slewing	308
267: Suction nozzle, raise/lower	309
268: Side brush, swing in/out	310
269: Side brush, pressure	311
270: Auto blanking, right hand side	312
271: Auxiliary brush, raise/lower	313
272: Auxiliary brush, left hand, swing in/out	314
273: Auxiliary brush, extend/retract	315
274: Hopper safety prop, kicker	316
275: Main control panel	318
276: Auxiliary control panel	319
277: Hopper controller remote	320
278: Display screen, operator, programmed	320
279: CR2012 cabinet module, node	320

280: Beacon switch	321
281: Sounder, main control panel	321
282: Camera monitor	321
283: Camera splitter	322
284: Fuses and relays, cab	322
285: Node cabinet	323
286: Nodes	324
287: Relays	324
288: Power connection link	324
289: Power post	325
290: Switch, gantry work light	325
291: Fuses, Nodes	326
292: Battery Junction box	327
293: Work light	328
294: LED rear marker light	328
295: Beacon	328
296: LED beacon	329
297: Cameras	329
298: Engine frame and covers general arrangement	335
299: Covers, engine frame	336
300: Door, left hand side, engine frame	337
301: Door, right hand side, engine frame	338
302: Hydraulic oil tank mounting, engine frame	339
303: Hydraulic tank and fittings	340
304: Hydraulic tank and fittings	341
305: Node and pneumatics cabinet mounting, engine frame	342
306: Node and pneumatics cabinet	343
307: Node and pneumatics cabinet	344
308: Node and pneumatics cabinet	345
309: Fuel tank mounting, engine frame	346
310: Fuel tank, fittings	347
311: Combined intercooler/radiator/hydraulic oil cooler mounting, engine frame	348
312: Safety bar, engine frame	349
313: Battery junction box and hydraulic oil filters mounting, engine frame	350
314: Fuel filters and fuel pump mounting, engine frame	351
315: Hopper raised sensor, engine frame	352
316: Work light, engine frame	353
317: Exhaust stack mounting, engine frame	354
318: Air intake stack mounting, engine frame	355
319: Flow control valve block and hydraulic manifold mountings, engine frame	356
320: Engine mounts, rear, engine frame	357
321: Engine mounts, front, engine frame	358
322: Expansion tank mounting, engine frame	359
323: ECU cover mounting, engine frame	360
324: Hydraulic cabinet door fittings, engine frame	361
325: Hydraulic cabinet valve block fittings, engine frame	362
326: End panels, engine frame	363
327: Engine frame	364
328: Subframe general arrangement	365
329: Subframe	366
330: Subframe and pipe, hose and wiring support brackets	367
331: Hopper safety prop	368
332: Floor plate, subframe and engine frame	369
333: Subframe hopper lift ram mounting	370
334: Access ladder and grab handle, subframe and engine frame	371
335: Subframe to engine frame mounting	372
336: Subframe to chassis mounting general arrangement	373

337: Subframe to chassis mountings, DAF	374
338: Subframe to chassis mountings, position 1, DAF	375
339: Subframe to chassis mountings, position 2, DAF	376
340: Subframe to chassis mountings, position 3, DAF	377
341: Subframe to chassis mountings, position 4, DAF	378
342: Subframe to chassis mountings lateral support, left side, DAF	379
343: Subframe to chassis mountings lateral support, right side, DAF	380
344: Subframe to chassis mountings, SCANIA	381
345: Subframe to chassis mountings, position 1, SCANIA	382
346: Subframe to chassis mountings, position 2, SCANIA	383
347: Subframe to chassis mountings, position 3, SCANIA	384
348: Subframe to chassis mountings, position 4, SCANIA	385
349: Subframe to chassis mountings lateral support, left side, SCANIA	386
350: Subframe to chassis mountings lateral support, right side, SCANIA	387
351: Subframe to chassis mountings, VOLVO	388
352: Subframe to chassis mountings, position 1, VOLVO	389
353: Subframe to chassis mountings, position 2, VOLVO	390
354: Subframe to chassis mountings, position 3, VOLVO	391
355: Subframe to chassis mountings, position 4, VOLVO	392
356: Subframe to chassis mountings lateral support, left side, VOLVO	393
357: Subframe to chassis mountings lateral support, right side, VOLVO	394
358: Subframe to chassis mountings, IVECO	395
359: Subframe to chassis mountings, position 1, IVECO	396
360: Subframe to chassis mountings, position 2, IVECO	397
361: Subframe to chassis mountings, position 3, IVECO	398
362: Subframe to chassis mountings, position 4, IVECO	399
363: Subframe to chassis mountings lateral support, left side, IVECO	400
364: Subframe to chassis mountings lateral support, right side, IVECO	401
365: Subframe to chassis mountings, Mercedes	402
366: Subframe to chassis mountings, position 1, Mercedes	403
367: Subframe to chassis mountings, position 2, Mercedes	404
368: Subframe to chassis mountings, position 3, Mercedes	405
369: Subframe to chassis mountings, position 4, Mercedes	406
370: Subframe to chassis mountings lateral support, left side, Mercedes	407
371: Subframe to chassis mountings lateral support, right side, Mercedes	408
372: Subframe to chassis mountings MAN 18.290	409
373: Subframe to chassis mountings, position 1, MAN	410
374: Subframe to chassis mountings, position 2, MAN	411
375: Subframe to chassis mountings, position 3, MAN	412
376: Subframe to chassis mountings, position 4, MAN	413
377: Subframe to chassis mountings lateral support, left side, MAN	414
378: Subframe to chassis mountings lateral support, right side, MAN	415
379: Subframe to chassis mountings, Freightliner	416
380: Subframe to chassis mountings, position 1, Freightliner	417
381: Subframe to chassis mountings, position 2, Freightliner	418
382: Subframe to chassis mountings, position 3, Freightliner	419
383: Subframe to chassis mountings, position 4, Freightliner	420
384: Subframe to chassis mountings lateral support, left side, Freightliner	421
385: Subframe to chassis mountings lateral support, right side, Freightliner	422
386: General layout, engine	424
387: Engine cradles and mounts	425
388: Engine mountings	426
389: Cooling fan, engine	427
390: Ancillary belt, alternator and engine speed sensors, engine	428
391: Starter motor, coolant temperature, rail pressure and charge air pressure/temp sensors, engine	429
392: Oil pressure sensor, engine	430
393: Fuel injectors and glow plugs	431

## List of figures

394: DEUTZ TCD 3.6 L4 engine	432
395: Fuel pump and filters, engine	433
396: Exhaust stack, engine	434
397: Air intake stack, engine	435
398: Expansion tank, engine	436
399: Combined intercooler/radiator/hydraulic oil cooler, engine	437
400: Centaflex coupling and fan pump housing plate, engine	439
401: General layout, cab components	442
402: Main control panel and operator screen mountings, cab components	443
403: Main control panel and operator screen mountings, cab components, Freightliner M2106 DS	444
404: Auxiliary control (door pod) mountings, cab components	445
405: Hopper controller remote, mountings, cab components	446
406: Hopper controller remote, mountings, cab components	447
407: CR2012 cabinet module, slave node, mountings, cab components	448
408: Warning labels	452
409: Information labels	453
410: Decals and badges	454



# Sweeping

<i>Description</i>	<i>Page</i>
Left hand leg and side brush arrangement . . . . .	26
Left hand leg and central brush mount . . . . .	27
Left hand dummy leg and central brush mount . . . . .	28
Left hand leg, side brush swing in/out cylinder mounting . . . . .	29
Left hand leg, side brush front skirt . . . . .	30
Left hand leg, side brush pipe clamps . . . . .	31
Left hand side brush king post, swing in/out arrangement . . . . .	32
Left hand side brush raise/lower arrangement . . . . .	33
Left hand side brush water jet arrangement . . . . .	34
Right hand leg and side brush arrangement . . . . .	35
Right hand leg and central brush mount . . . . .	36
Right hand dummy leg and central brush mount . . . . .	37
Right hand leg, side brush swing in/out cylinder mounting . . . . .	38
Right hand leg, side brush front skirt . . . . .	39
Right hand leg, side brush pipe clamps . . . . .	40
Right hand side brush, king post, swing in/out arrangement . . . . .	41
Right hand side brush raise/lower arrangement . . . . .	42
Right hand side brush water jet arrangement . . . . .	43
Side brush and motor arrangement . . . . .	44
Central brush (wide sweep) general arrangement . . . . .	46
Central brush (wide sweep) mounting arrangement . . . . .	47
Central brush (wide sweep) support, fixed slew . . . . .	48
Central brush (wide sweep) dual sweep support slewing arrangement . . . . .	49
Central brush (wide sweep) motor end arrangement . . . . .	51
Central brush (wide sweep) bearing end arrangement . . . . .	52
Central brush (wide sweep) motor arrangement . . . . .	53
Central brush (wide sweep) bearing arrangement . . . . .	54
Central brush (wide sweep) skirt arrangement . . . . .	55
Central brush (wide sweep) cover and shaft arrangement . . . . .	56
Central brush (wide sweep), brush and brush core arrangement . . . . .	57
Central brush (wide sweep) extended, general arrangement . . . . .	58
Central brush (wide sweep) extended, support . . . . .	59
Central brush (wide sweep) extended, motor end arrangement . . . . .	60
Central brush (wide sweep) extended, bearing end arrangement . . . . .	61
Central brush (wide sweep) extended, motor arrangement . . . . .	62
Central brush (wide sweep) extended, bearing arrangement . . . . .	63
Central brush (wide sweep) extended, skirt arrangement . . . . .	64
Central brush (wide sweep) extended cover and shaft . . . . .	65
Central brush (wide sweep) extended, brush core and shaft . . . . .	66
Auxiliary side brush, left hand, general arrangement . . . . .	67
Auxiliary side brush, left hand, carrier . . . . .	68
Auxiliary side brush, pneumatic cylinder, extend/retract . . . . .	69
Auxiliary brush, left hand, swing in/out . . . . .	70
Auxiliary brush, left hand, king post . . . . .	71
Auxiliary brush, left hand, raise/lower linkage . . . . .	72
Auxiliary brush, brush and motor assembly . . . . .	73
Auxiliary brush, left hand, water jet arrangement . . . . .	74
Auxiliary brush, bracket pipe/hose support . . . . .	75
Auxiliary brush, speed control valve, brush . . . . .	76
Auxiliary brush, work lamp . . . . .	77



Left hand leg and side brush arrangement

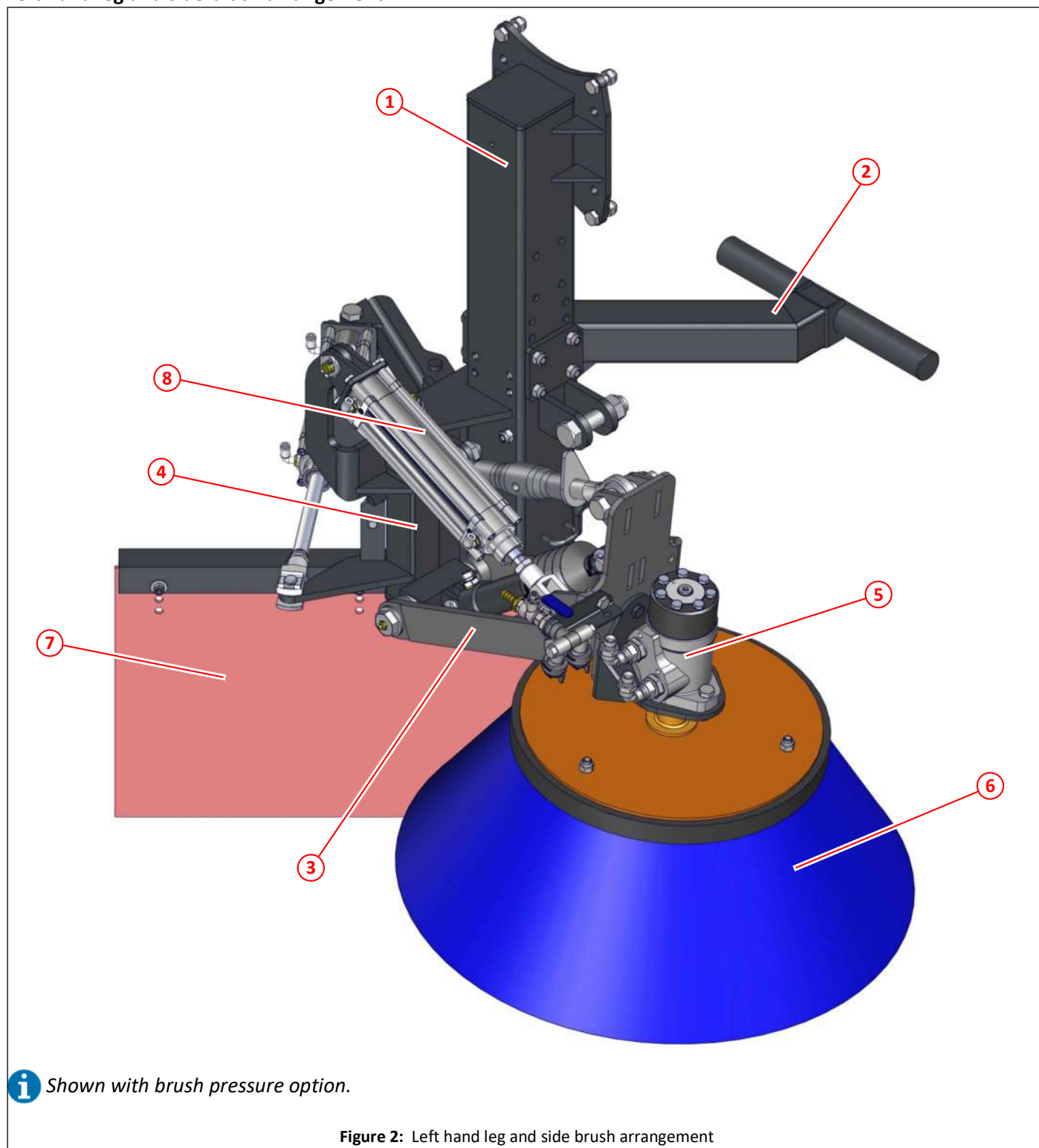

Item	Part No	Qty	Description	
①	034265	1	Left hand leg	27
②	034334	1	Left hand central brush (wide sweep) adjustable mount	27,28
③			Left hand side brush raise/lower assembly	33
④			Left hand side brush king post, swing in/out arrangement	32
⑤			Side brush motor assembly	275
⑥			Side brushes	44
⑦			Front skirt, side brush	30
⑧			Side brush pressure cylinder (option)	311

Left hand leg and central brush mount

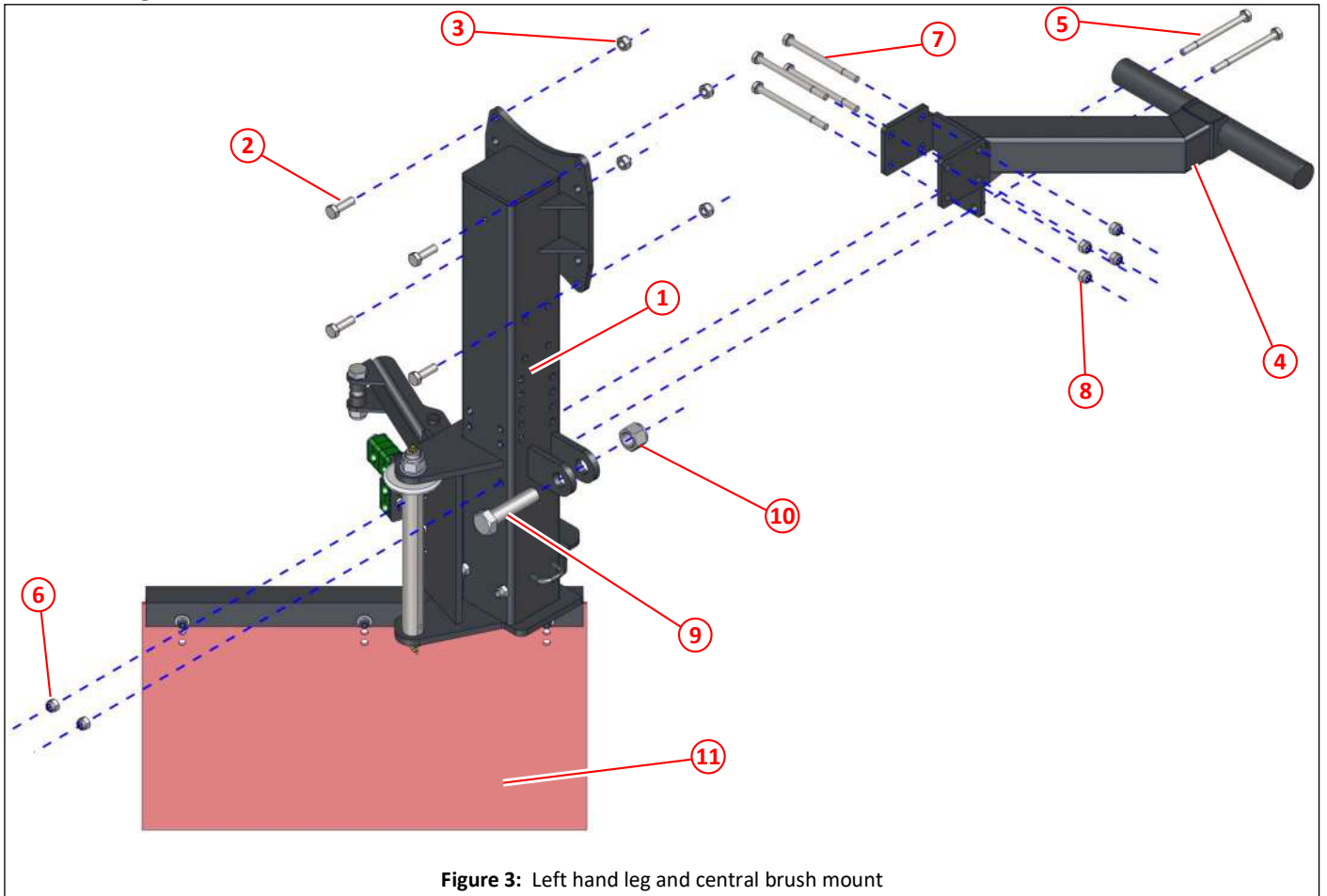

Figure 3: Left hand leg and central brush mount

Item	Part No	Qty	Description	
①	034265	1	Left hand leg	26
②	011053	4	Set screw M12 x 35	
③	011077	4	Nyloc nut M12	
④	034334	1	Left hand central brush (wide sweep) adjustable mount	26,28
⑤	011407	2	Bolt M10 x 120	
⑥	011075	2	Nyloc nut M10	
⑦	000075	4	Bolt M10 x 130	
⑧	011075	4	Nyloc nut M10	
⑨	011118	1	Bolt $\frac{7}{8}$ " UNF x $3\frac{1}{2}$ "	
⑩	011119	1	Nyloc nut $\frac{7}{8}$ " UNF	
⑪			Front skirt, side brush	30

Left hand dummy leg and central brush mount

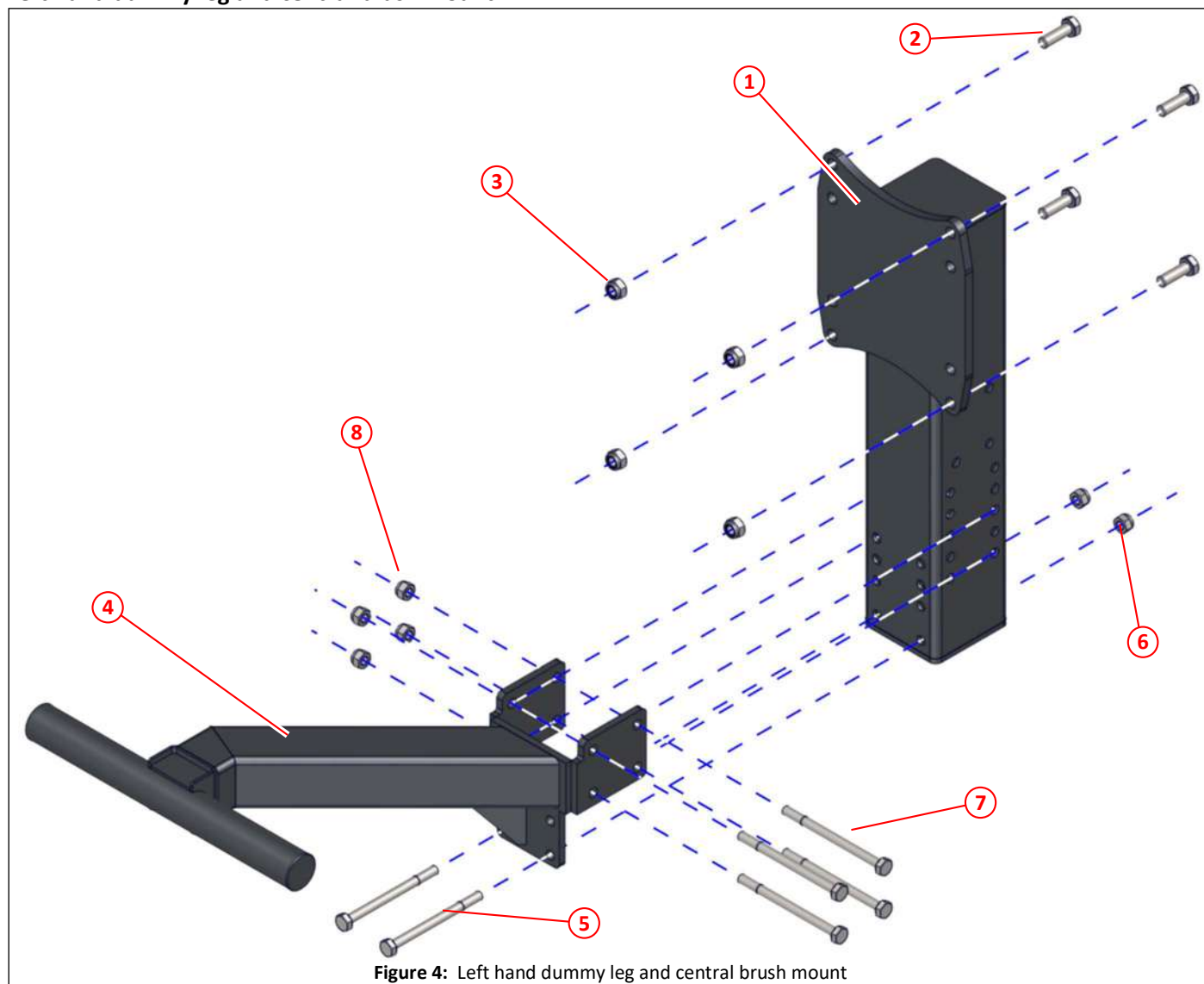

Figure 4: Left hand dummy leg and central brush mount

Item	Part No	Qty	Description	
①	042867	1	Dummy leg	
②	011053	4	Set screw M12 x 35	
③	011077	4	Nyloc nut M12	
④	034334	1	Left hand central brush (wide sweep) adjustable mount	26,27
⑤	011407	2	Bolt M10 x 120	
⑥	011075	2	Nyloc nut M10	
⑦	000075	4	Bolt M10 x 130	
⑧	011075	4	Nyloc nut M10	

Left hand leg, side brush swing in/out cylinder mounting

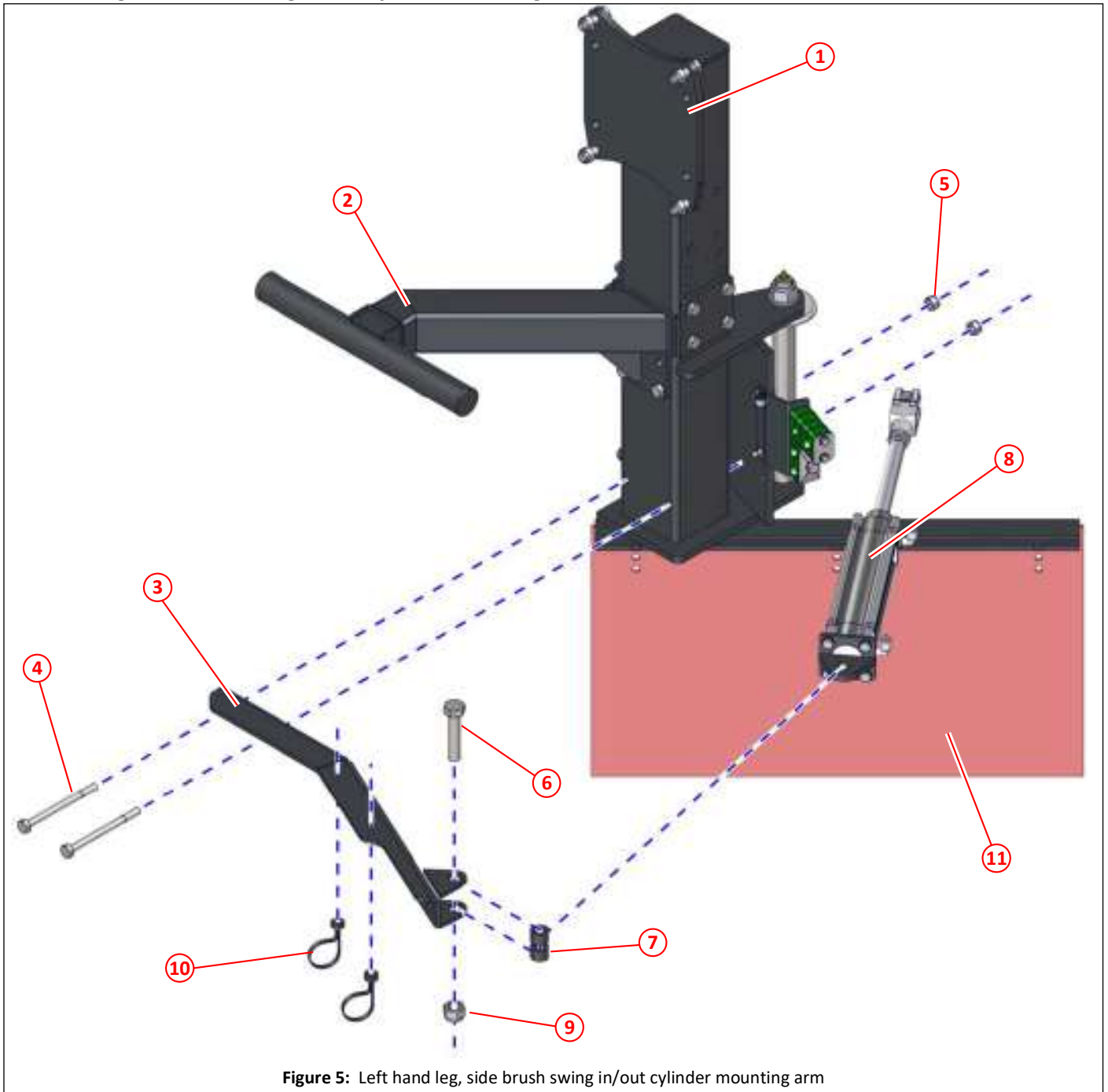

Figure 5: Left hand leg, side brush swing in/out cylinder mounting arm

Item	Part No	Qty	Description	
①	034265	1	Left hand leg	
②	034334	1	Left hand central brush (wide sweep) adjustable mount	26,27
③	021721 *	1	Left hand side brush swing in/out cylinder mounting arm	67
④	011407	2	Bolt M10 x 120	
⑤	011075	2	Nyloc nut M10	
⑥	011260	1	Bolt M16 x 70	
⑦	011000	2	Rubber spacers, 15mm long, ( $\frac{5}{8}$ " hose)	
⑧	022587	1	Pneumatic cylinder, side brush swing in/out, assembly	310
⑨	011060	1	Nyloc nut M16	
⑩	005061	2	Cable tie, round head	
⑪			Front skirt, side brush	30

\*. If an auxiliary brush is fitted please see page 67 for a replacement of this part

Left hand leg, side brush front skirt

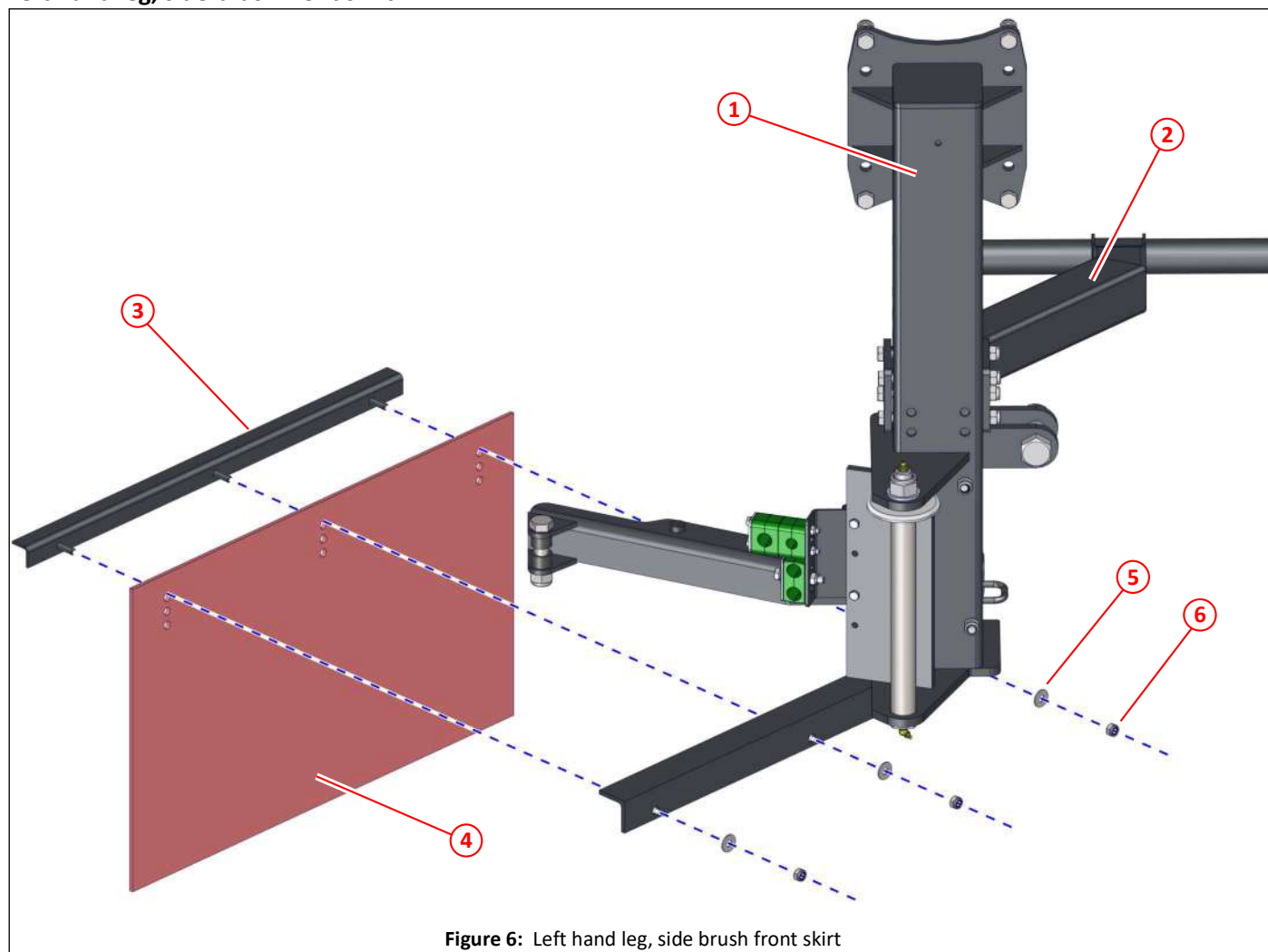

Figure 6: Left hand leg, side brush front skirt

Item	Part No	Qty	Description	
①	034265	1	Left hand leg	26
②	034334	1	Left hand central brush (wide sweep) adjustable mount	26,27
③	010275	1	Skirt clamp	
④	010247	1	Front skirt, side brush, 3-pitch, heavy duty	
⑤	011092	3	Plain washer M8	
⑥	011073	3	Nyloc nut M8	

Left hand leg, side brush pipe clamps

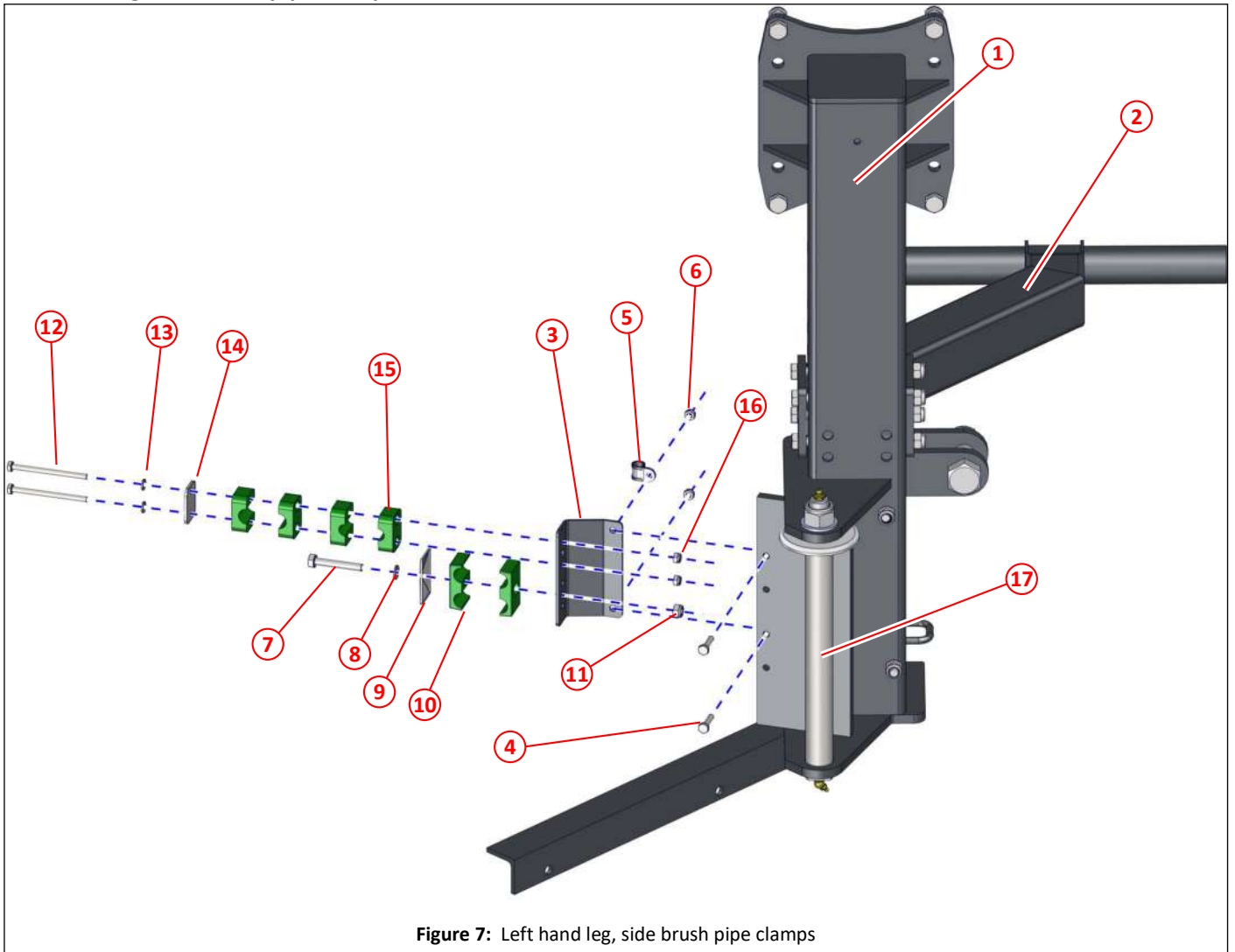

Figure 7: Left hand leg, side brush pipe clamps

Item	Part No	Qty	Description	
①	034265	1	Left hand leg	26,27
②	034334	1	Left hand central brush (wide sweep) adjustable mount	26,27
③	031306	1	Clamp support, lower	
④	011087	2	Set screw M6 x 25	
⑤	021914	1	P-clip ø12, rubber sealed	
⑥	011071	2	Nyloc nut M6	
⑦	011016	1	Set screw M8 x 50	
⑧	011093	1	Spring washer M8	
⑨	031319	1	Clamp plate, flat	
⑩	031318	2	Clamp 3/8" hose, twin	
⑪	011073	1	Nyloc nut M8	
⑫	000221	2	Bolt M6 x 80	
⑬	011091	2	Spring washer M6	
⑭	031317	1	Clamp plate, flat	
⑮	031316	4	Clamp 1/4" hose, single	
⑯	011071	2	Nyloc nut M6	
⑰	013007	1	King pin	32



Left hand side brush king post, swing in/out arrangement

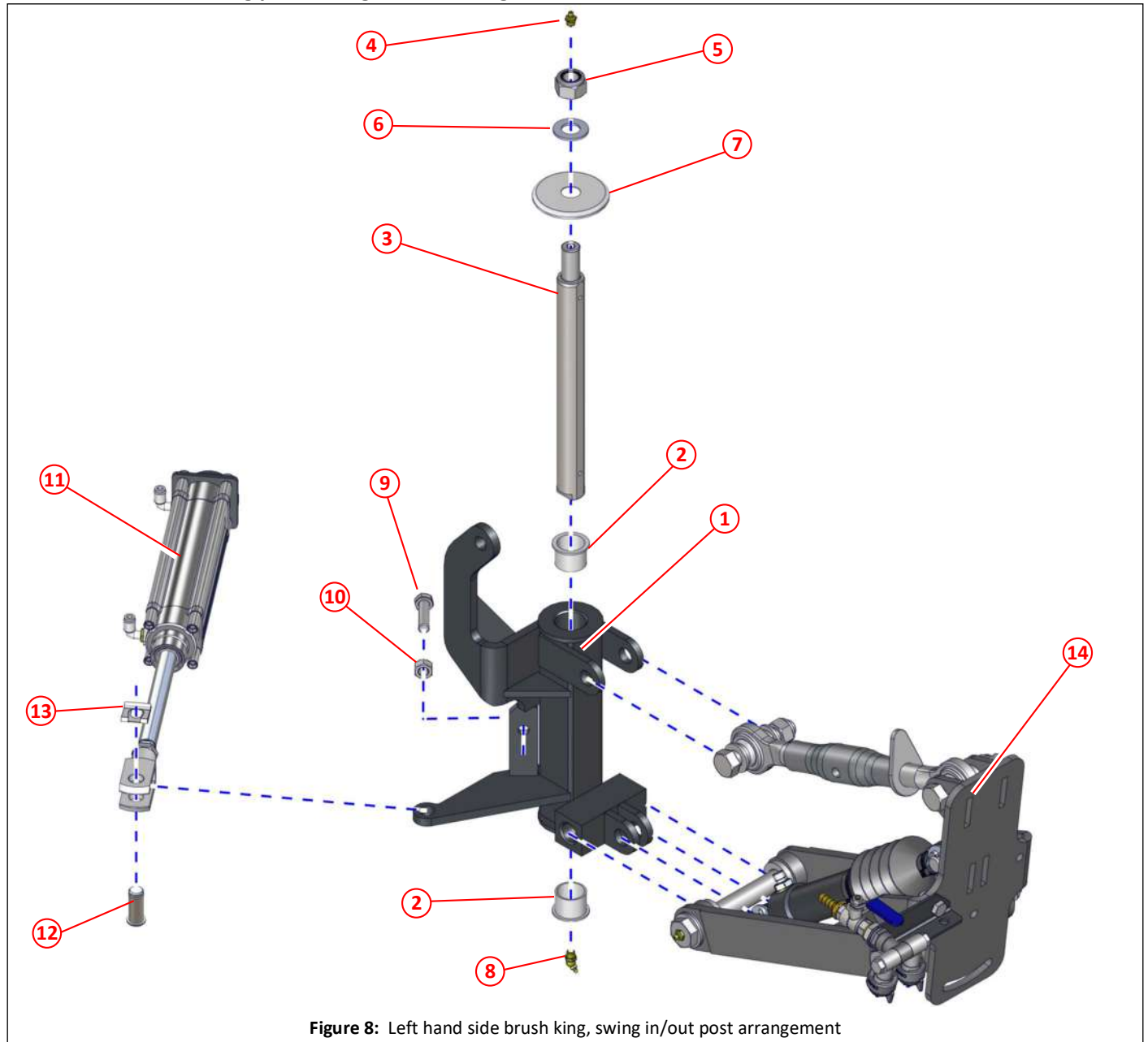

Figure 8: Left hand side brush king, swing in/out post arrangement

Item	Part No	Qty	Description	
①	023120	1	King post, left hand side brush	26
②	013012	2	Bush	
③	013007	1	King pin	31
④	010903	1	Grease nipple $\frac{1}{8}$ " BSP, straight	
⑤	011082	1	Nyloc nut M20	
⑥	011102	1	Plain washer M20	
⑦	013013	1	Dirt shield	
⑧	010901	1	Grease nipple $\frac{1}{8}$ " BSP, 135°	
⑨	011054	1	Set screw M12 x 45	
⑩	011076	1	Full nut M12	
⑪	022587	1	Pneumatic cylinder, side brush swing in/out, assembly	310
⑫	022673	1	Clevis pin	
⑬	022674	1	Clip, retaining, M16	
⑭			Side brush raise/lower assembly	33



Left hand side brush raise/lower arrangement

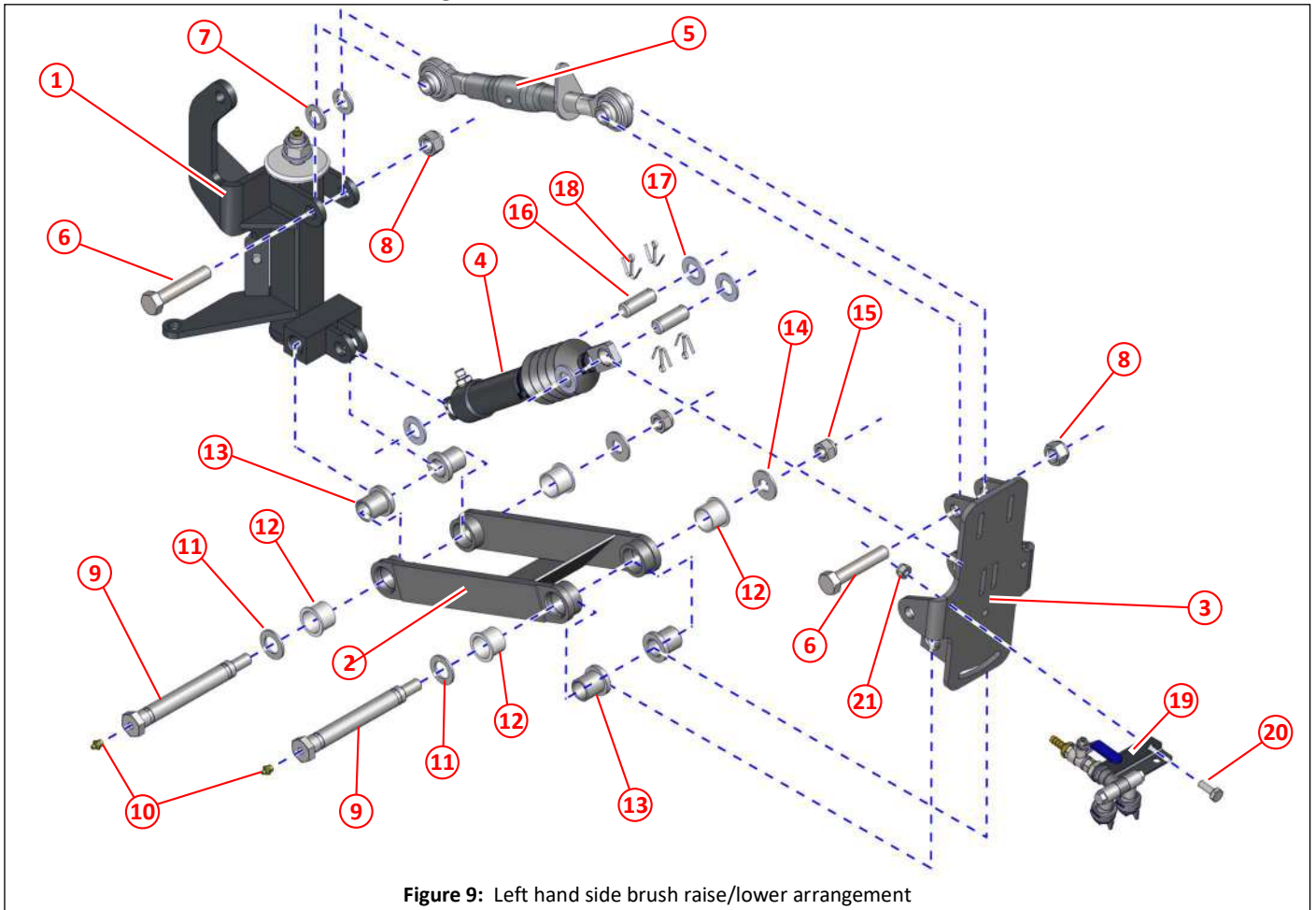

Figure 9: Left hand side brush raise/lower arrangement

Item	Part No	Qty	Description	
①	023120	1	King post, left hand side brush	32
②	014801	1	Brush link, side brush	
③	023121	1	Swivel plate, side brush	34
④	024539	1	Ram No 12 240/340 assembly	273
⑤	013011	1	Top link, side brush	
⑥	011140	2	Bolt M18 x 90	
⑦	011138	2	Plain washer M18	
⑧	011139	2	Nyloc nut M18	
⑨	014796	2	Pivot bolt, side brush	
⑩	010903	2	Grease nipple $\frac{1}{8}$ " BSP, straight	
⑪	014798	2	Washer 24 x 40 x 3	
⑫	013012	4	Bush	
⑬	014799	4	Spacer sleeve, side brush	
⑭	014797	2	Washer 17 x 40 x 3	
⑮	011060	2	Nyloc nut M16	
⑯	010067	2	Pin 20 x 50	
⑰	011102	4	Plain washer M20	
⑱	011122	4	Split pin $\frac{3}{16}$ " x $1\frac{1}{2}$ "	
⑲			Water spray nozzle assembly	34
⑳	011031	1	Set screw M10 x25	
㉑	011075	1	Nyloc nut M10	

## Left hand side brush water jet arrangement

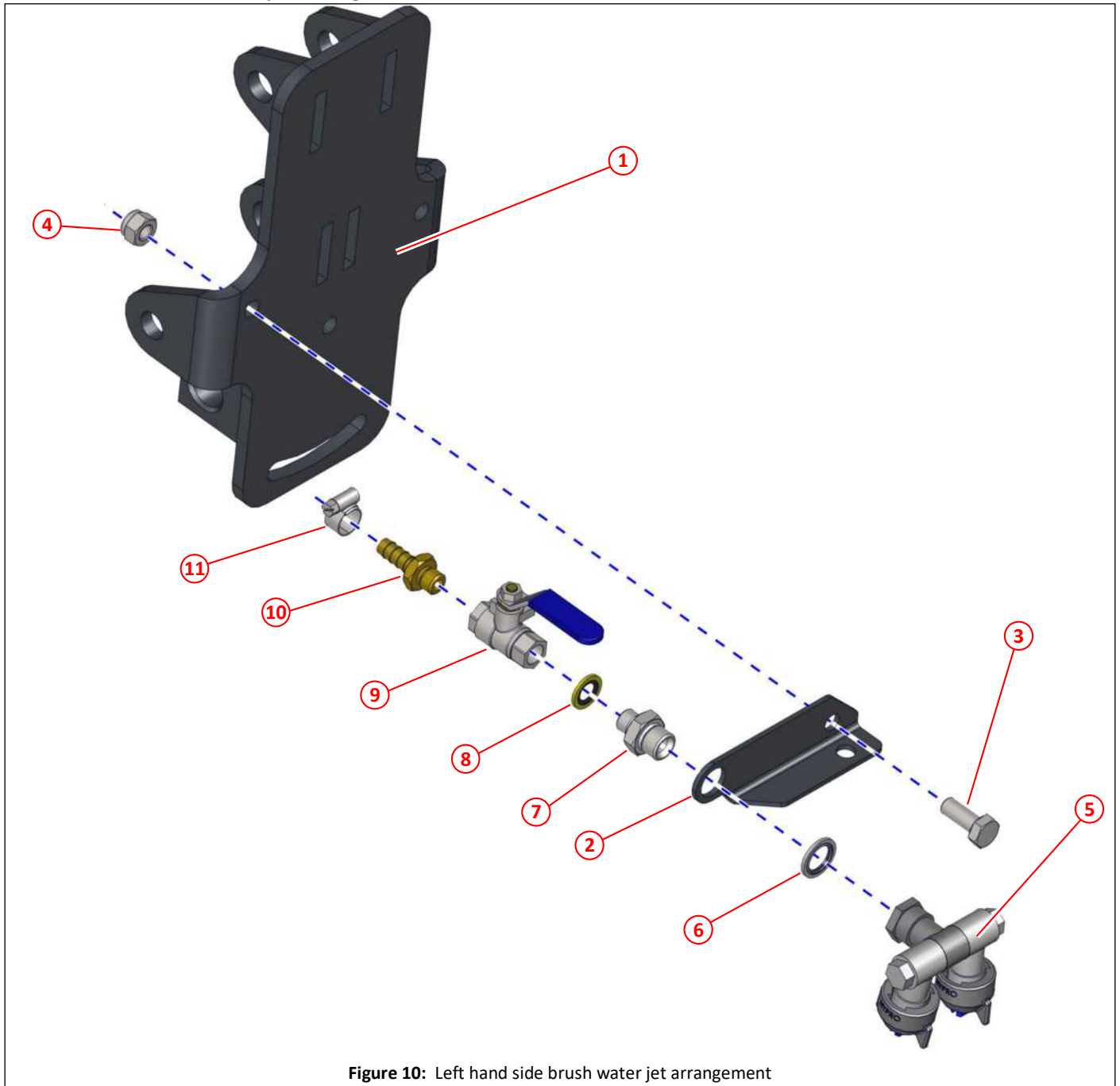
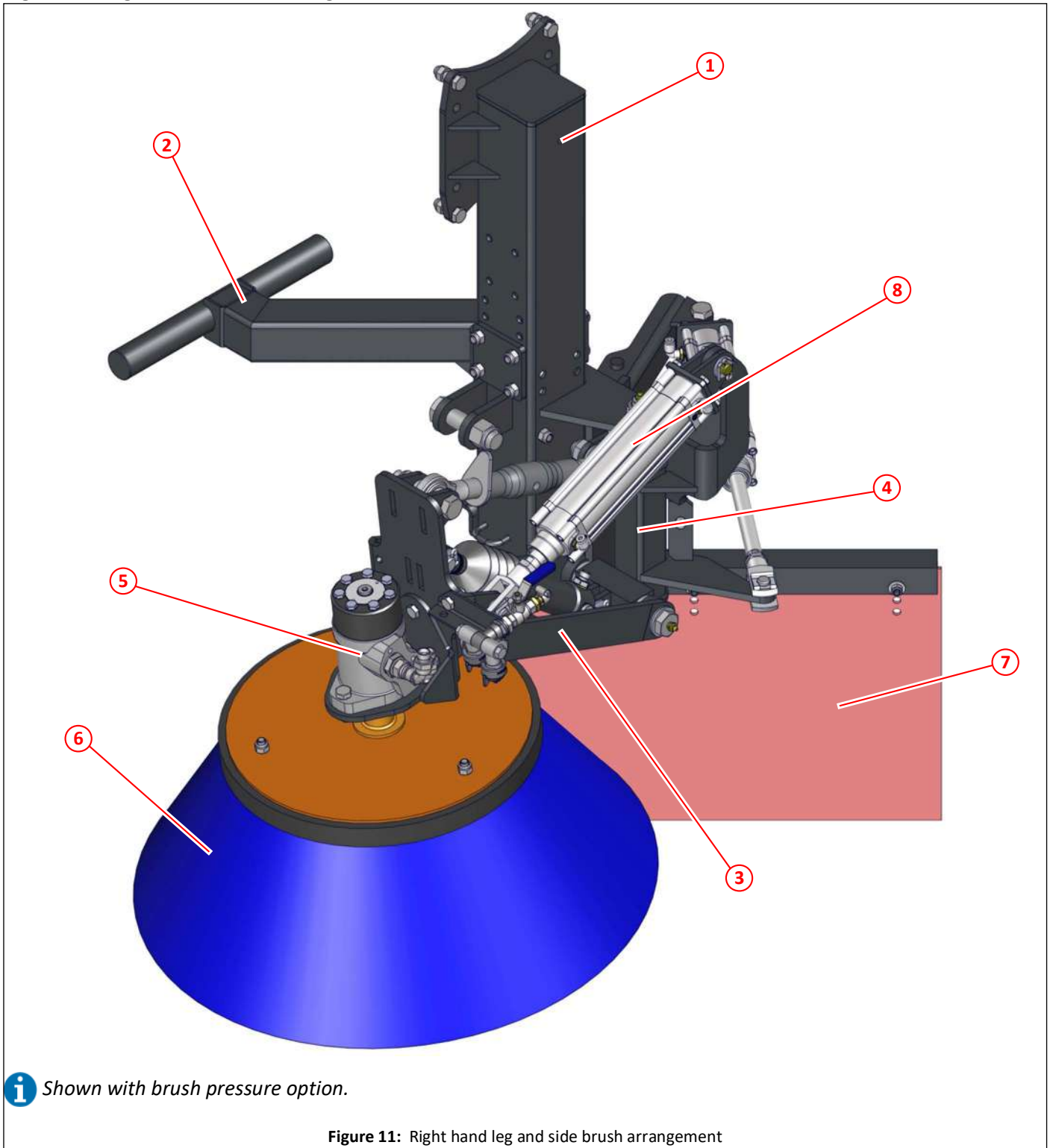

Figure 10: Left hand side brush water jet arrangement

Item	Part No	Qty	Description	
①	023121	1	Swivel plate, side brush	33
②	036042	1	Nozzle bracket, twin nozzles, side brush, for left hand side	
③	011031	1	Set screw M10 x25	
④	011075	1	Nyloc nut M10	
⑤	036044	1	Double swivel nozzle assembly	225
⑥	011153	1	Dowty seal $\frac{3}{8}$ " BSP	
⑦	011152	1	Dowty seal $\frac{1}{4}$ " BSP	
⑧	011199	1	Adapter $\frac{3}{8}$ " x $\frac{1}{4}$ " BSP	
⑨	011743	1	Valve, ball, $\frac{1}{4}$ " BSP	
⑩	010922	1	Adapter $\frac{1}{4}$ " BSP x $\frac{3}{8}$ " hose tail	
⑪	010516	1	Hose clamp, worm drive, No. M00 (ø11mm-ø16mm)	

Right hand leg and side brush arrangement



**i** Shown with brush pressure option.

Figure 11: Right hand leg and side brush arrangement

Item	Part No	Qty	Description	
①	034266	1	Right hand leg	36
②	034335	1	Right hand central brush (wide sweep) adjustable mount	36,37
③			Right hand side brush raise/lower assembly	42
④			Right hand side brush, king post, swing in/out assembly	41
⑤			Side brush motor assembly	275
⑥			Side brushes	44
⑦			Front skirt, side brush	39
⑧			Side brush pressure cylinder (option)	311

Right hand leg and central brush mount

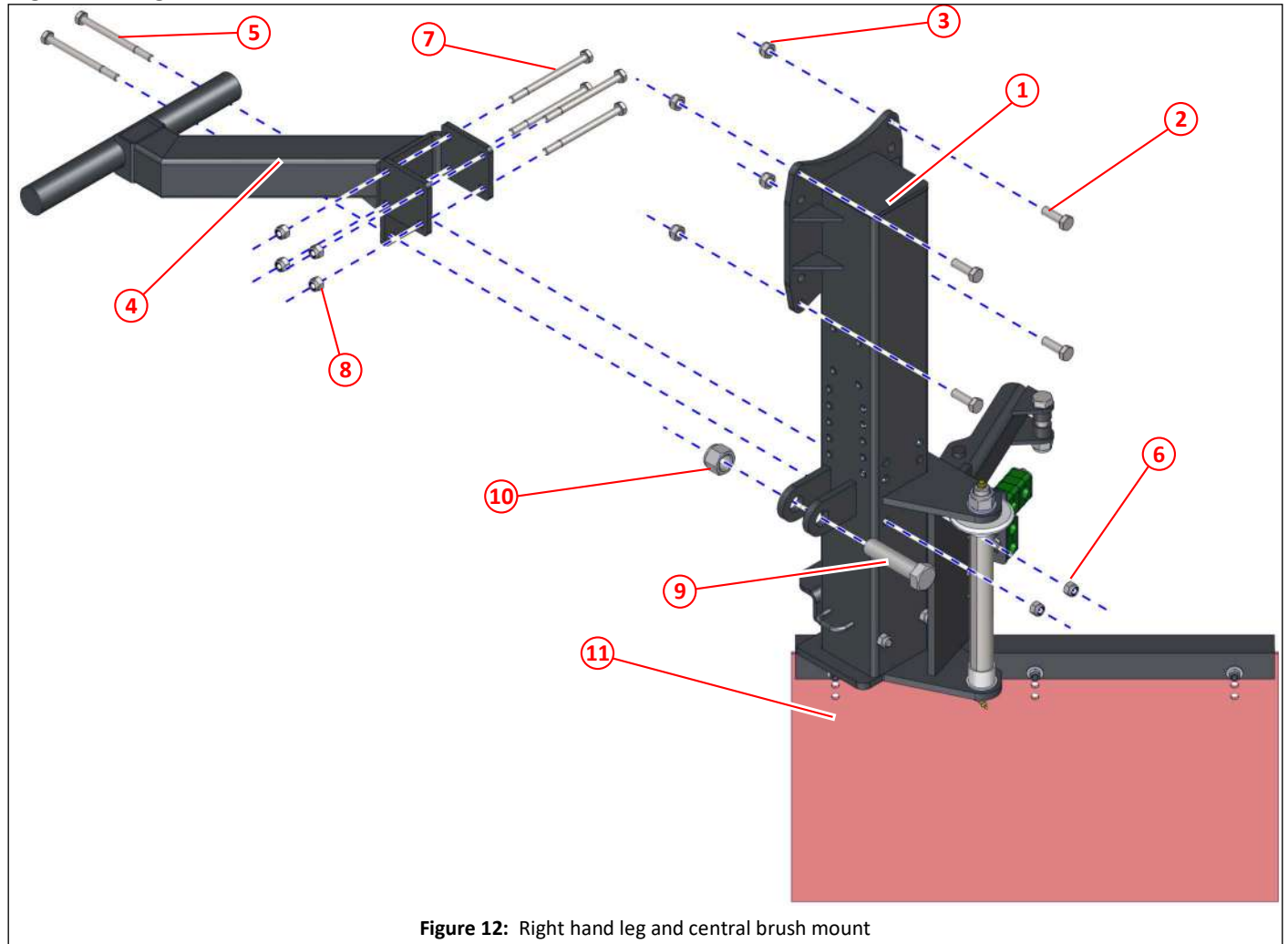

Figure 12: Right hand leg and central brush mount

Item	Part No	Qty	Description	
①	034266	1	Right hand leg	35
②	011053	4	Set screw M12 x 35	
③	011077	4	Nyloc nut M12	
④	034335	1	Right hand central brush (wide sweep) adjustable mount	35,37
⑤	011407	2	Bolt M10 x 120	
⑥	011075	2	Nyloc nut M10	
⑦	000075	4	Bolt M10 x 130	
⑧	011075	4	Nyloc nut M10	
⑨	011118	1	Bolt $\frac{7}{8}$ " UNF x $3\frac{1}{2}$ "	
⑩	011119	1	Nyloc nut $\frac{7}{8}$ " UNF	
⑪			Front skirt, side brush	39

Right hand dummy leg and central brush mount

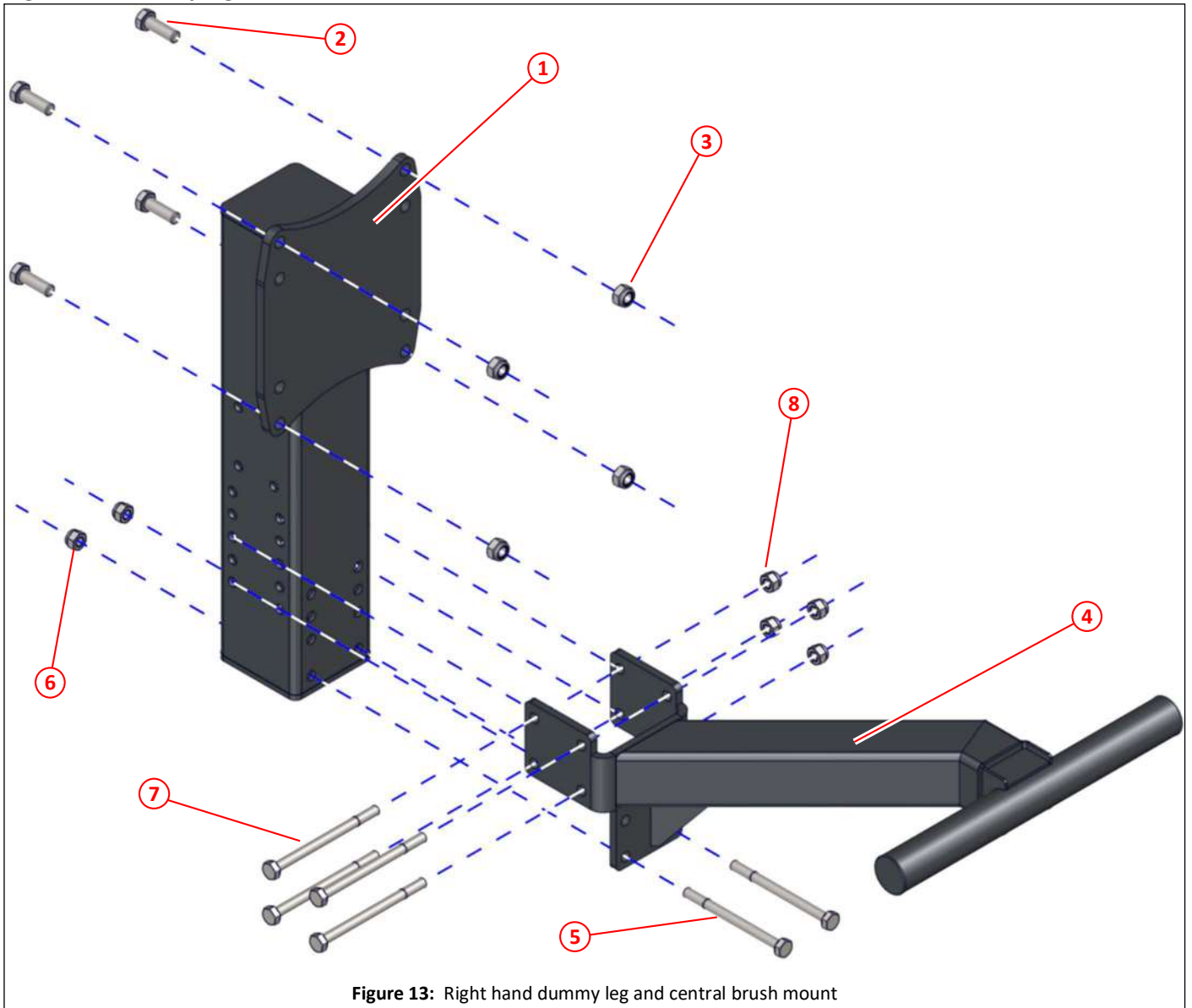

Figure 13: Right hand dummy leg and central brush mount

Item	Part No	Qty	Description	
①	042867	1	Dummy leg	
②	011053	4	Set screw M12 x 35	
③	011077	4	Nyloc nut M12	
④	034335	1	Right hand central brush (wide sweep) adjustable mount	35,36,
⑤	011407	2	Bolt M10 x 120	
⑥	011075	2	Nyloc nut M10	
⑦	000075	4	Bolt M10 x 130	
⑧	011075	4	Nyloc nut M10	



Right hand leg, side brush swing in/out cylinder mounting

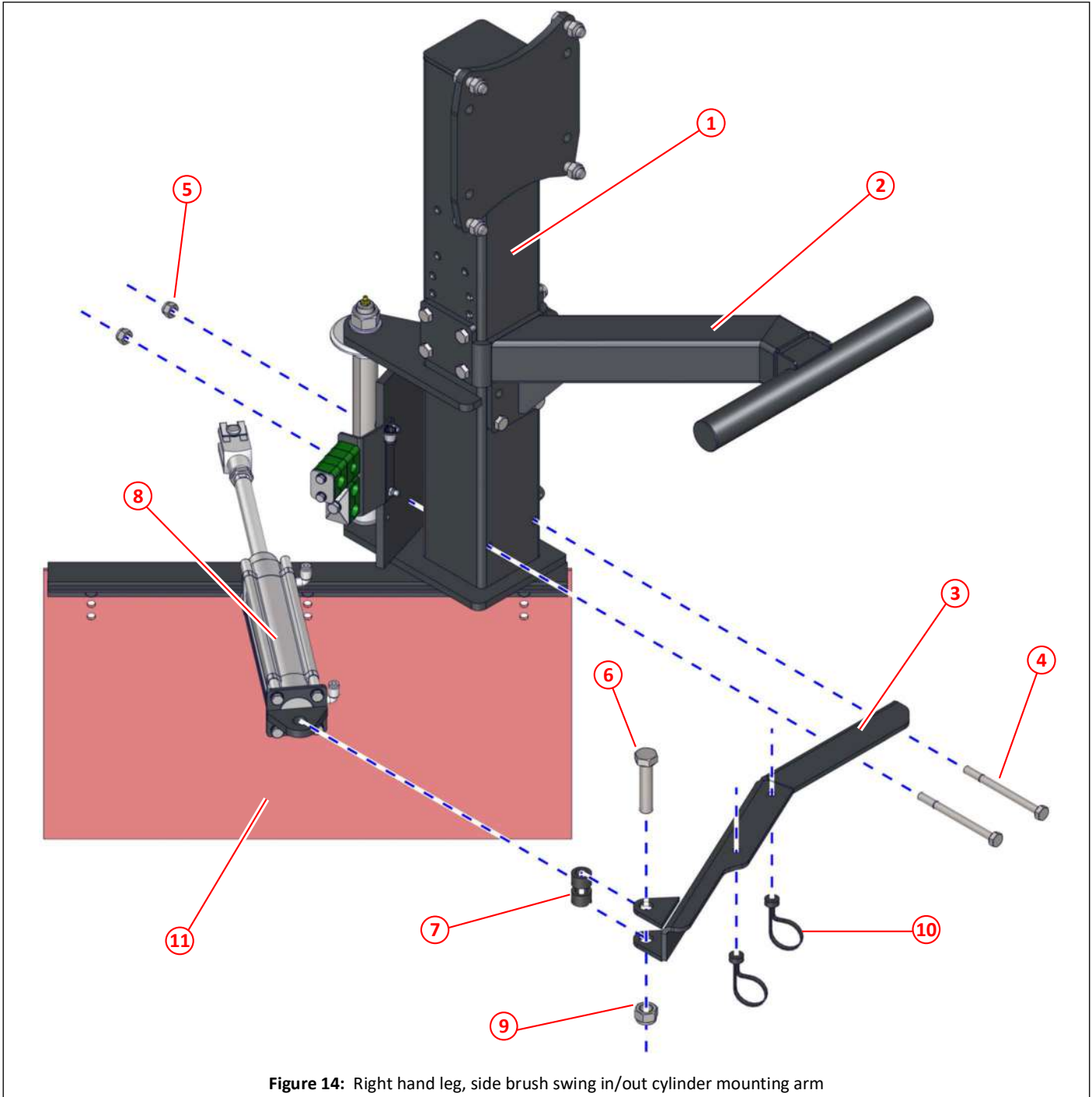

Figure 14: Right hand leg, side brush swing in/out cylinder mounting arm

Item	Part No	Qty	Description	
①	034266	1	Right hand leg	35
②	034335	1	Right hand central brush (wide sweep) adjustable mount	35,36
③	021722	1	Right hand side brush swing in/out cylinder mounting arm	
④	011407	2	Bolt M10 x 120	
⑤	011075	2	Nyloc nut M10	
⑥	011260	1	Bolt M16 x 70	
⑦	011000	2	Rubber spacers, 15mm long, ( $\frac{5}{8}$ " hose)	
⑧	022587	1	Pneumatic cylinder, side brush swing in/out, assembly	310
⑨	011060	1	Nyloc nut M16	
⑩	005061	2	Cable tie, round head	
⑪			Front skirt, side brush	39

Right hand leg, side brush front skirt

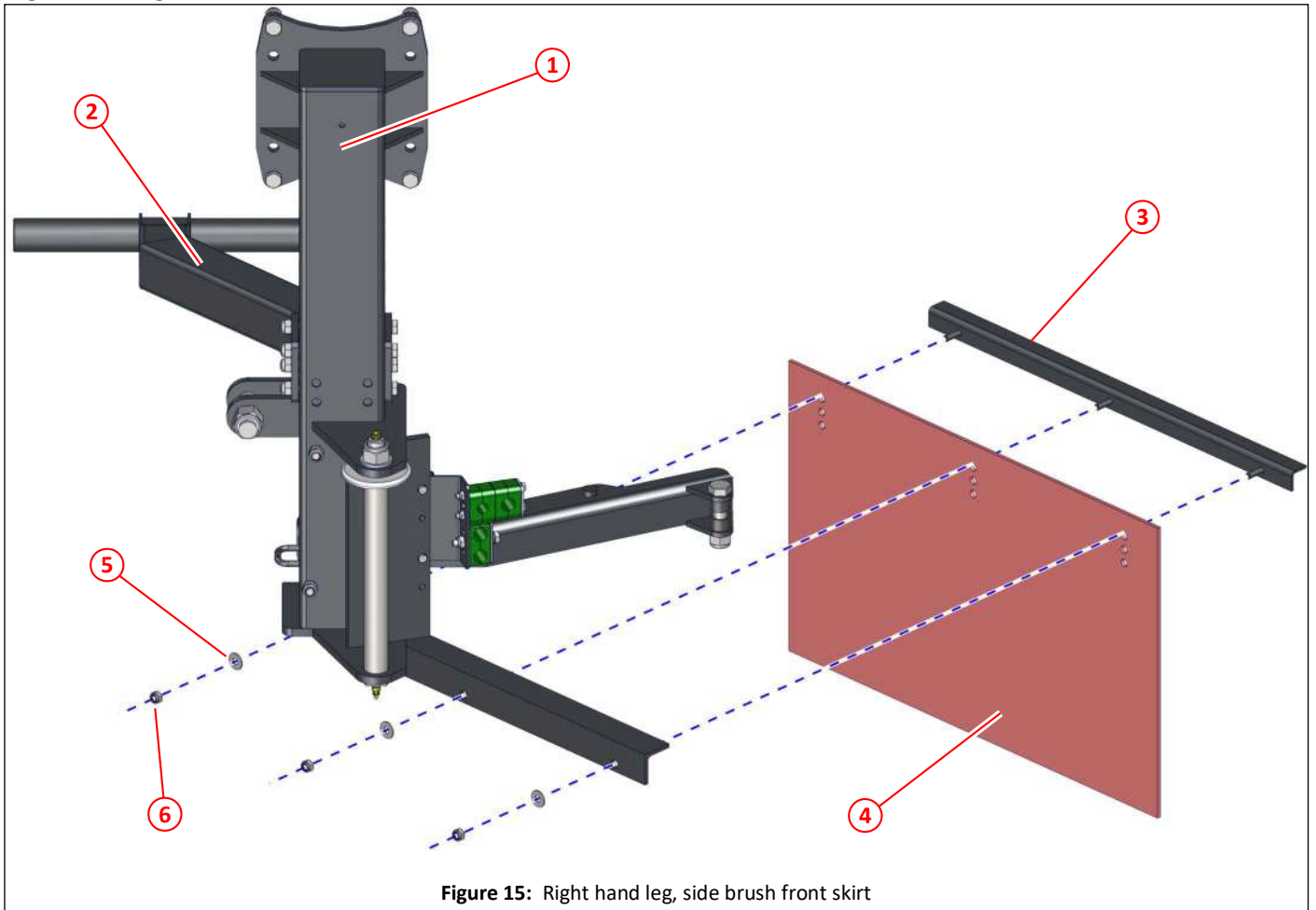

Figure 15: Right hand leg, side brush front skirt

Item	Part No	Qty	Description	
①	034266	1	Left hand leg	35
②	034335	1	Left hand central brush (wide sweep) adjustable mount	36
③	010275	1	Skirt clamp	
④	010247	1	Front skirt, side brush, 3-pitch, heavy duty	
⑤	011092	3	Plain washer M8	
⑥	011073	3	Nyloc nut M8	



Right hand leg, side brush pipe clamps

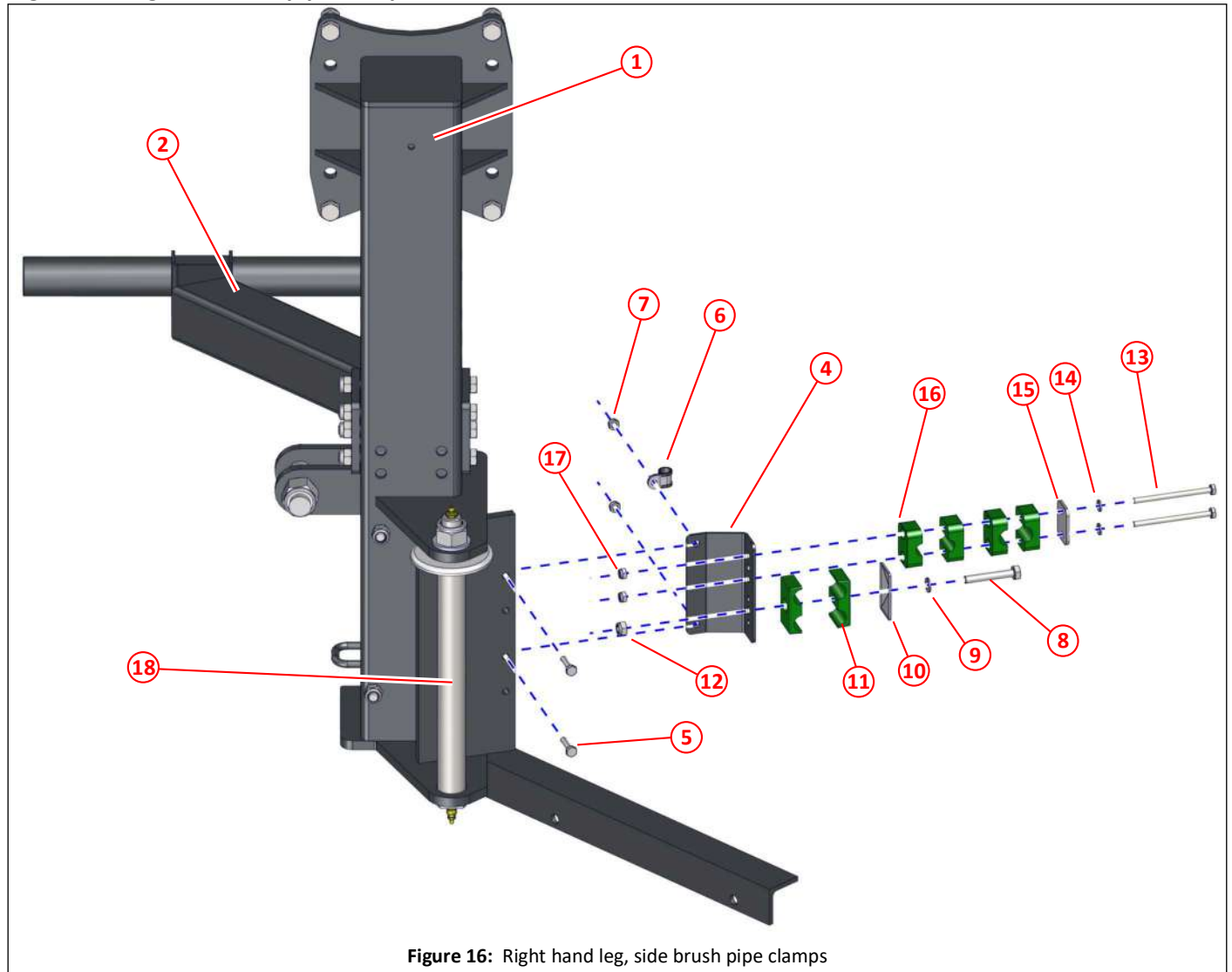

Figure 16: Right hand leg, side brush pipe clamps

Item	Part No	Qty	Description	
①	034266	1	Right hand leg	35
②	034335	1	Right hand central brush (wide sweep) adjustable mount	36
③	031306	1	Clamp support, lower	
④	011087	2	Set screw M6 x 25	
⑤	021914	1	P-clip ø12, rubber sealed	
⑥	011071	2	Nyloc nut M6	
⑦	011016	1	Set screw M8 x 50	
⑧	011093	1	Spring washer M8	
⑨	031319	1	Clamp plate, flat	
⑩	031318	2	Clamp 3/8" hose, twin	
⑪	011073	1	Nyloc nut M8	
⑫	000221	2	Bolt M6 x 80	
⑬	011091	2	Spring washer M6	
⑭	031317	1	Clamp plate, flat	
⑮	031316	4	Clamp 1/4" hose, single	
⑯	011071	2	Nyloc nut M6	
⑰	013007	1	King pin	41

Right hand side brush, king post, swing in/out arrangement

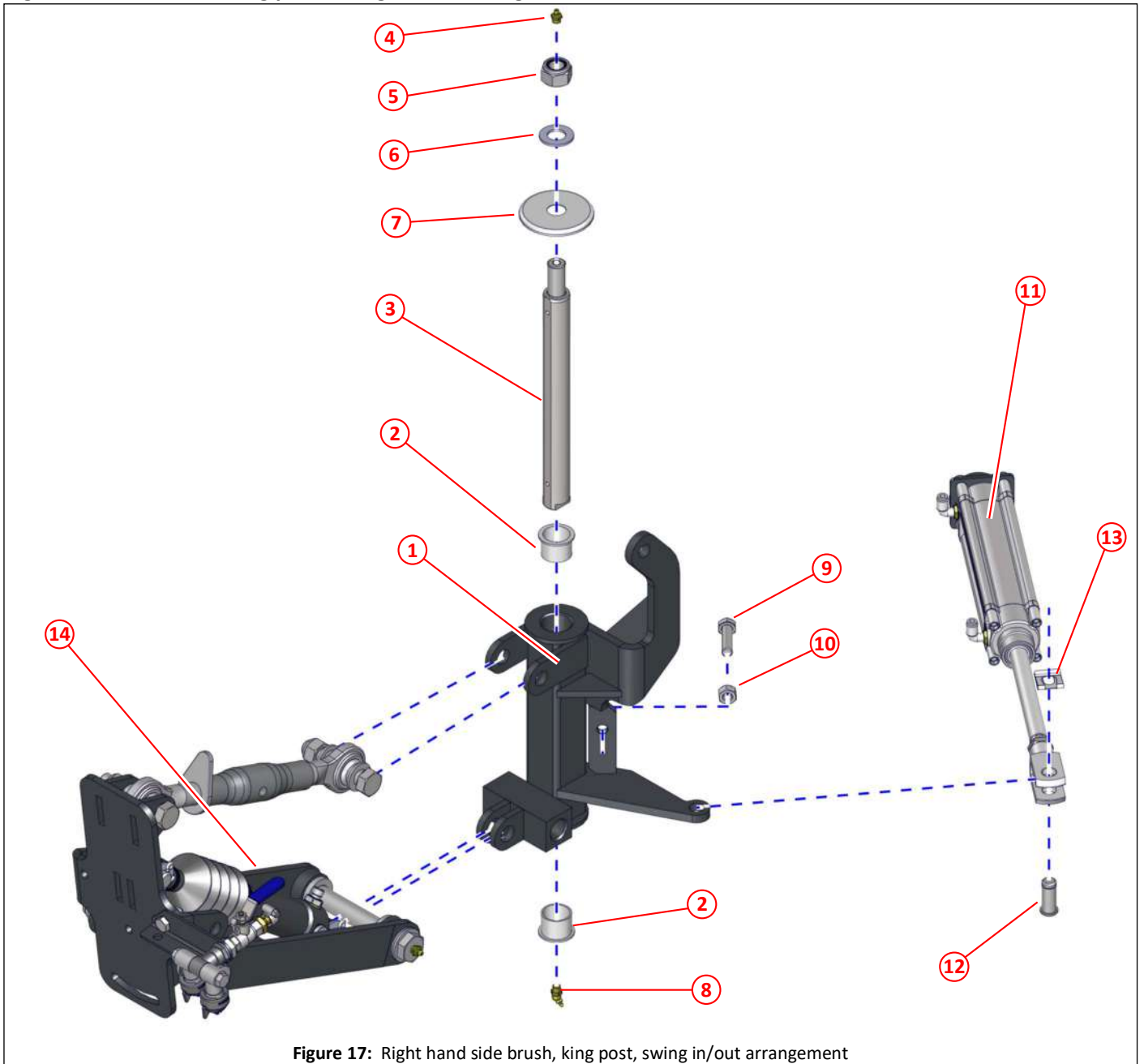

Figure 17: Right hand side brush, king post, swing in/out arrangement

Item	Part No	Qty	Description	
①	023124	1	King post, right hand side brush	35
②	013012	2	Bush	
③	013007	1	King pin	40
④	010903	1	Grease nipple $\frac{1}{8}$ " BSP, straight	
⑤	011082	1	Nyloc nut M20	
⑥	011102	1	Plain washer M20	
⑦	013013	1	Dirt shield	
⑧	010901	1	Grease nipple $\frac{1}{8}$ " BSP, 135°	
⑨	011054	1	Set screw M12 x 45	
⑩	011076	1	Full nut M12	
⑪	022587	1	Pneumatic cylinder, side brush swing in/out, assembly	310
⑫	022673	1	Clevis pin	
⑬	022674	1	Clip, retaining, M16	
⑭			Side brush raise/lower assembly	42

## Right hand side brush raise/lower arrangement

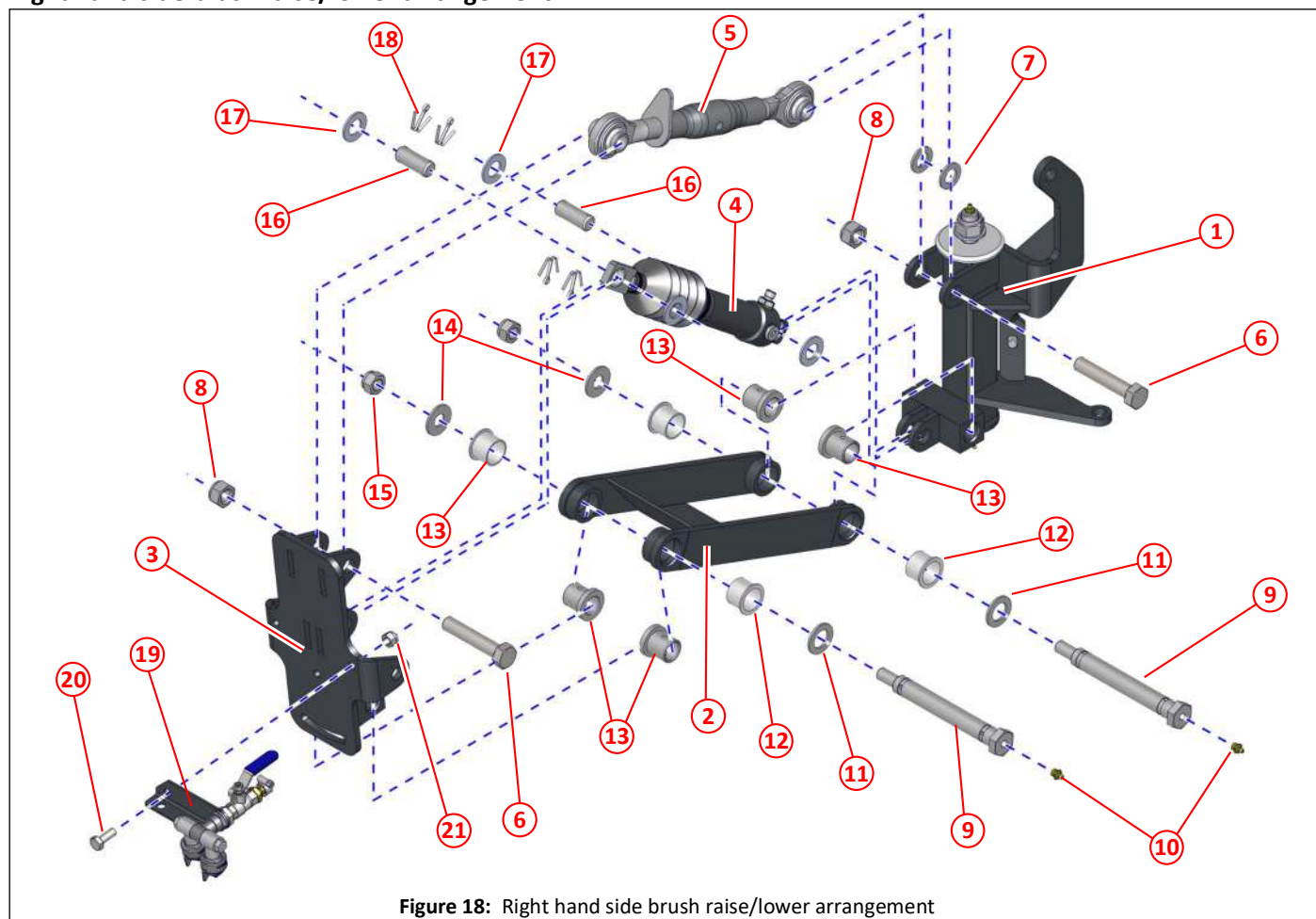

Figure 18: Right hand side brush raise/lower arrangement

Item	Part No	Qty	Description	
①	023124	1	King post, right hand side brush	41
②	014801	1	Brush link, side brush	
③	023121	1	Swivel plate, side brush	43
④	024539	1	Ram No 12 240/340 assembly	273
⑤	013011	1	Top link, side brush	
⑥	011140	2	Bolt M18 x 90	
⑦	011138	2	Plain washer M18	
⑧	011139	2	Nyloc nut M18	
⑨	014796	2	Pivot bolt, side brush	
⑩	010903	2	Grease nipple $\frac{1}{8}$ " BSP, straight	
⑪	014798	2	Washer 24 x 40 x 3	
⑫	013012	4	Bush	
⑬	014799	4	Spacer sleeve, side brush	
⑭	014797	2	Washer 17 x 40 x 3	
⑮	011060	2	Nyloc nut M16	
⑯	010067	2	Pin 20 x 50	
⑰	011102	4	Plain washer M20	
⑱	011122	4	Split pin $\frac{3}{16}$ " x $1\frac{1}{2}$ "	
⑲			Water spray nozzle assembly	43
⑳	011031	1	Set screw M10 x25	
㉑	011075	1	Nyloc nut M10	

Right hand side brush water jet arrangement

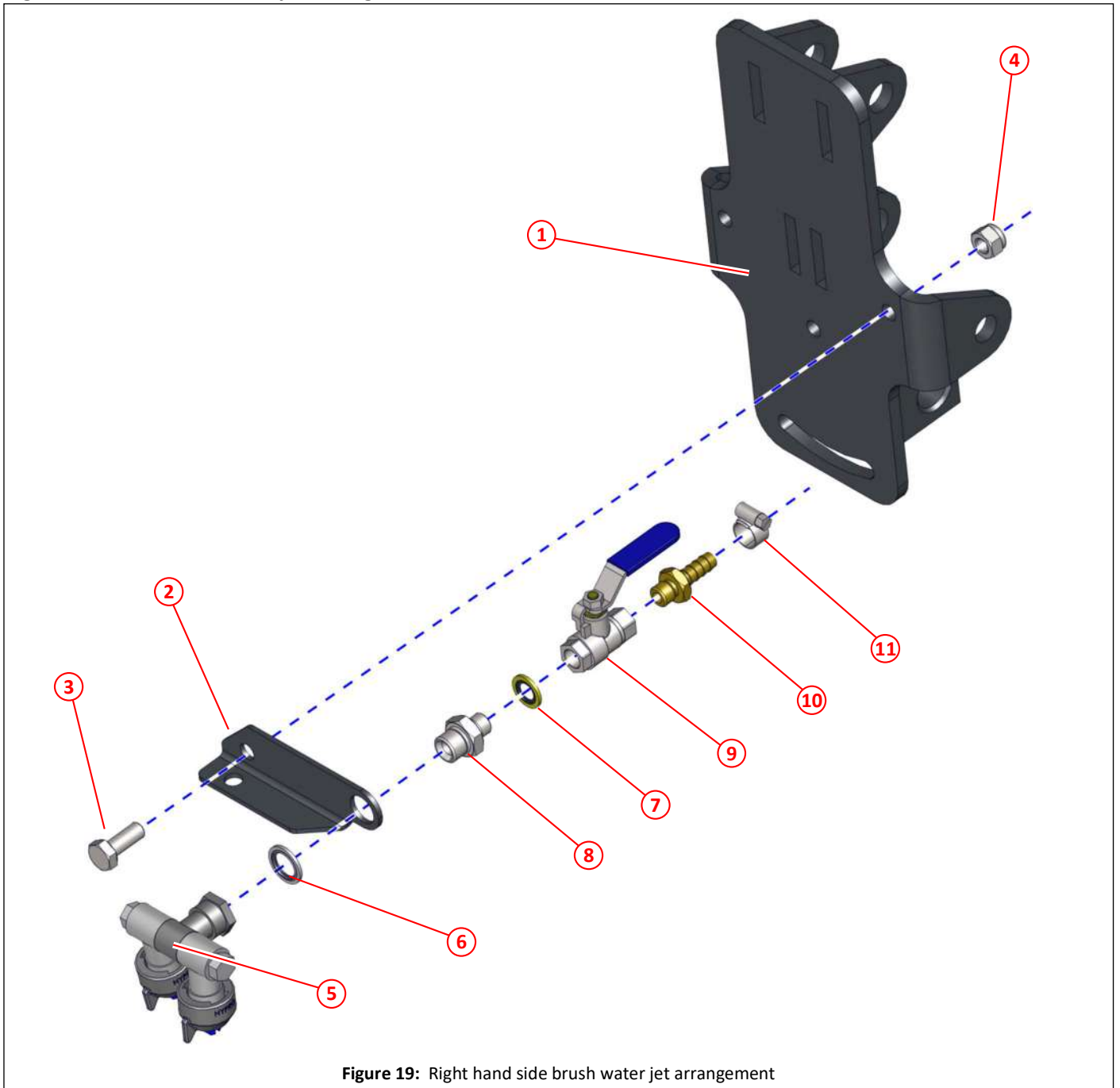

Figure 19: Right hand side brush water jet arrangement

Item	Part No	Qty	Description	
①	023121	1	Swivel plate, side brush	42
②	036042	1	Nozzle bracket, twin nozzles, side brush, for right hand side	
③	011031	1	Set screw M10 x25	
④	011075	1	Nyloc nut M10	
⑤	036044	1	Double swivel nozzle assembly	226
⑥	011153	1	Dowty seal $\frac{3}{8}$ " BSP	
⑦	011152	1	Dowty seal $\frac{1}{4}$ " BSP	
⑧	011199	1	Adapter $\frac{3}{8}$ " x $\frac{1}{4}$ " BSP	
⑨	011743	1	Valve, ball, $\frac{1}{4}$ " BSP	
⑩	010922	1	Adapter $\frac{1}{4}$ " BSP x $\frac{3}{8}$ " hose tail	
⑪	010516	1	Hose clamp, worm drive, No. M00 ( $\phi$ 11mm- $\phi$ 16mm)	

## Side brush and motor arrangement

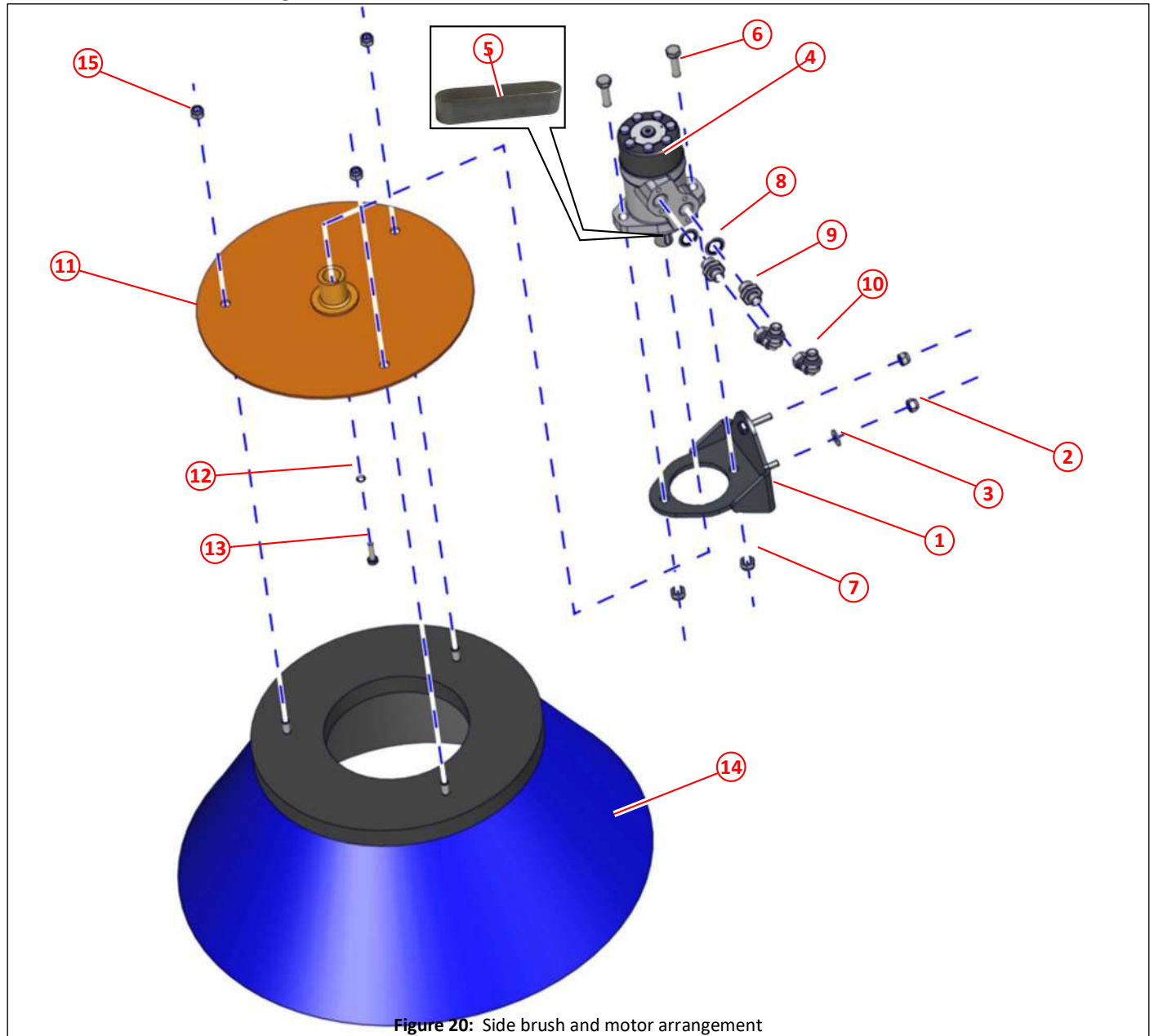

Figure 20: Side brush and motor arrangement

Item	Part No	Qty	Description
①	010007	1	Motor bracket
②	011075	2	Nyloc nut M10
③	011094	1	Plain washer M10
④	010749	1	Motor 3597 (OMP 200)
⑤	011515	1	Key for motor
⑥	011069	2	Bolt M12 x 40
⑦	011077	2	Nyloc nut M12
⑧	011154	2	Dowty seal $\frac{1}{2}$ " BSP
⑨	011167	2	Adapter $\frac{1}{2}$ " BSP x $\frac{3}{8}$ " BSP
⑩	011221	2	Elbow, swept, $\frac{3}{8}$ " BSP
⑪	014067	1	Brush disc, side
⑫	040197	1	Schnorr safety washer type VS8
⑬	011012	1	Set screw M8 x 30
⑭	023473	1	Brush, steel, $\varnothing$ 400- $\varnothing$ 650
⑮	011075	3	Nyloc nut M10

Page intentionally left blank



Central brush (wide sweep) general arrangement

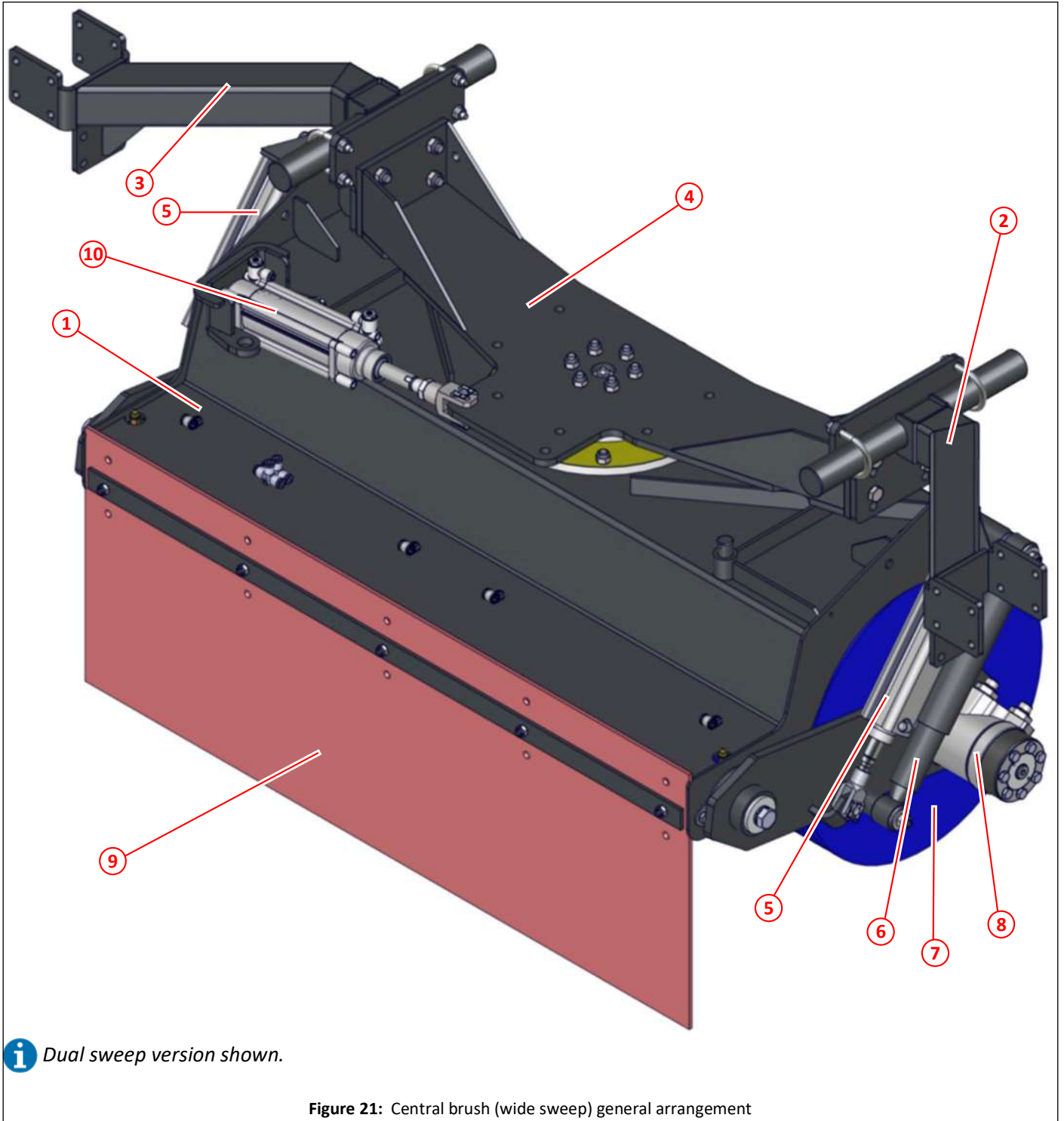

Item	Part No	Qty	Description	
①			Central brush (wide sweep)	56
②	034334	1	Adjustable bar, left hand	27
③	034335	1	Adjustable bar, right hand	36
④	024155	1	Bracket, wide sweep support	48,49
⑤	020602	2	Pneumatic cylinder 40 x 125, central brush (wide sweep) raise/lower	51,52
⑥	014603	2	Shock absorber 320/500	51,52
⑦	037588	1	Brush core assembly	57
⑧	010566	1	Motor 3596 (OMP 100)	51,53,276
⑨	022516	1	Skirt, central brush (wide sweep)	55
⑩	020767	1	Pneumatic cylinder 50 x 100, central brush (wide sweep) slew	49,308



Central brush (wide sweep) mounting arrangement

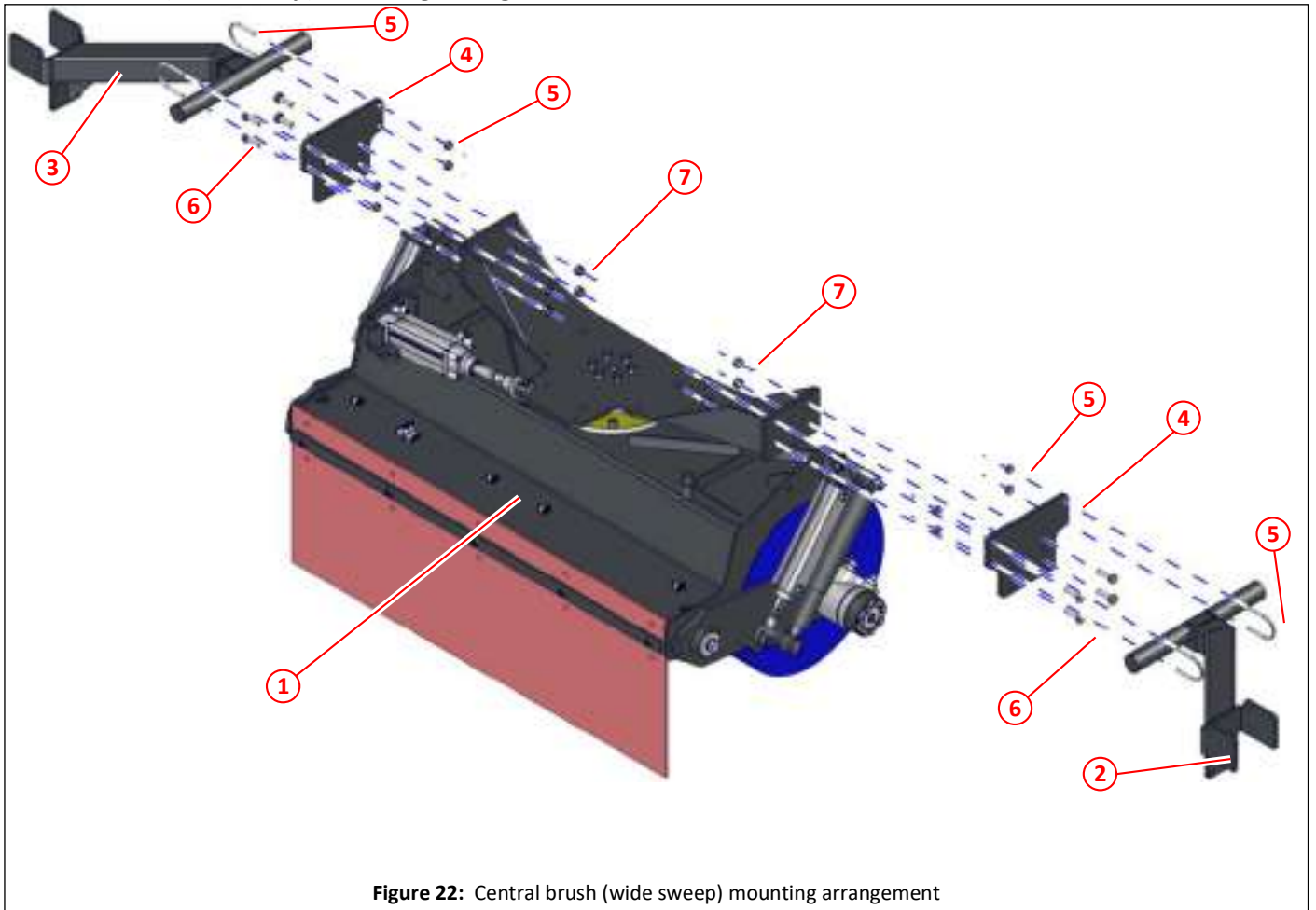

Figure 22: Central brush (wide sweep) mounting arrangement

Item	Part No	Qty	Description	
①			Central brush (wide sweep)	56
②	034334	1	Adjustable bar, left hand	27
③	034335	1	Adjustable bar, right hand	36
④	034336	2	Drop plate	
⑤	023148	4	'U' clamp 1½"	
⑥	011053	8	Set screw M12 x 35	
⑦	011077	8	Nyloc nut M12	

Central brush (wide sweep) support, fixed slew

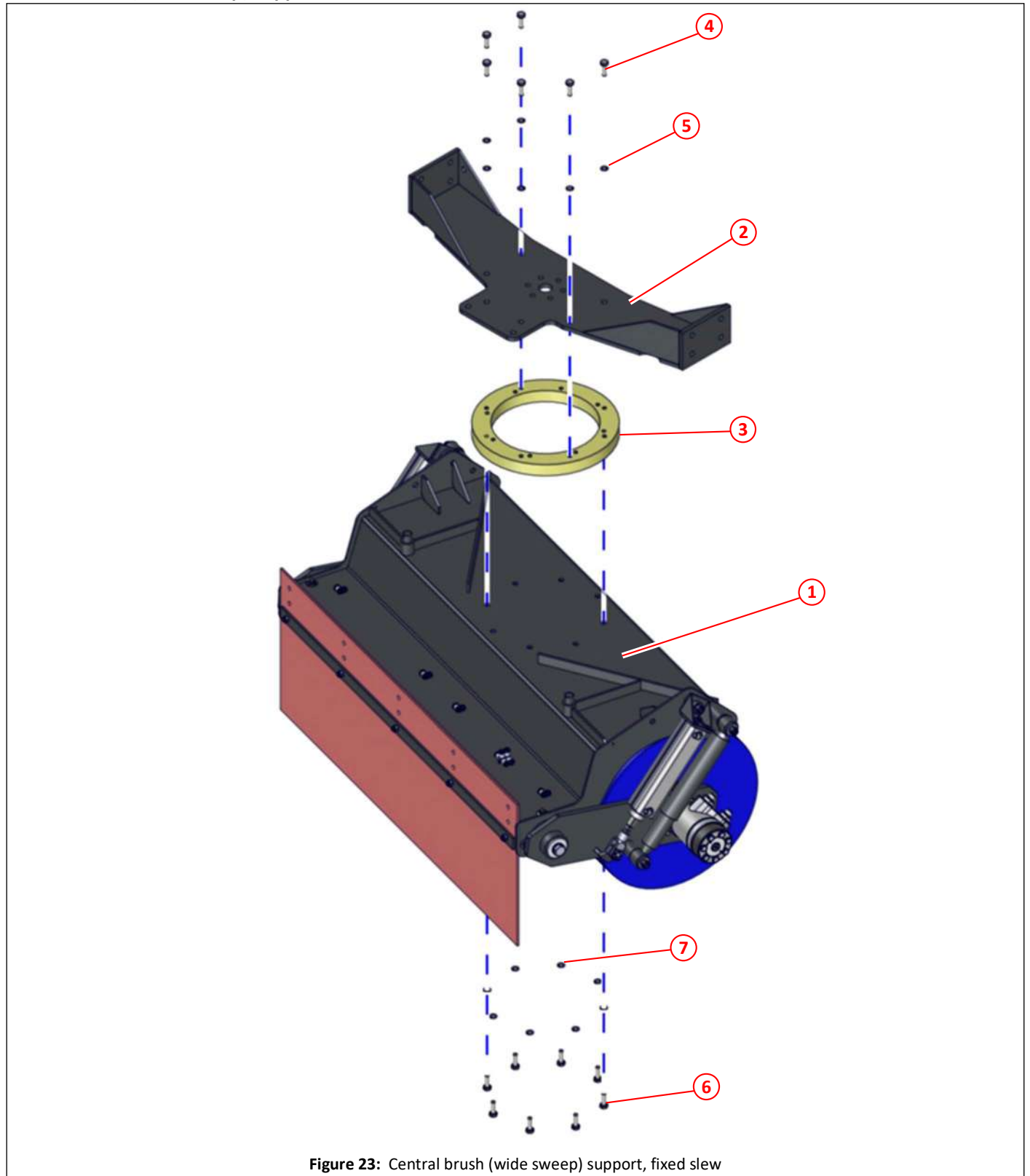

Figure 23: Central brush (wide sweep) support, fixed slew

Item	Part No	Qty	Description	
①			Central brush (wide sweep)	56
②	024155	1	Bracket, wide sweep support	46
③	020919	1	Adapter ring, fixed slew	
④	011032	6	Set screw M10 x 30	
⑤	011095	6	Spring washer M10	
⑥	011032	8	Set screw M10 x 30	
⑦	011095	8	Spring washer M10	

Central brush (wide sweep) dual sweep support slewing arrangement

Item	Part No	Qty	Description	
①			Central brush (wide sweep)	56
②	024155	1	Bracket, wide sweep support	46
③	011032	8	Set screw M10 x 30	
④	000183	6	Screw, socket, countersunk M10 x 65	
⑤	024151	1	Clamp plate wide sweep	
⑥	000167	6	Screw, countersunk, M10 x 40	
⑦	024154	1	Clamp ring wide sweep	
⑧	011075	8	Nyloc nut M10	
⑨	024149	1	Bearing, ball, $\phi 100 \times \phi 150 \times 16$ (16020)	
⑩	024148	1	Oil seal, $\phi 120 \times \phi 140 \times 13$	
⑪	024152	1	Bearing housing wide sweep	
⑫	024150	1	Spigot wide sweep	
⑬	011075	6	Nyloc nut M10	
⑭	013792	1	Grease nipple $\frac{1}{4}$ " BSP	
⑮	020767	1	Pneumatic cylinder 50 x 100, central brush (wide sweep) slew	308
⑯	036621	1	Clevis and pin, special	
⑰	023269	2	Safety fastener $\phi 12$	
⑱	036620	1	Mounting bracket, air ram, slewing central brush (wide sweep)	
⑲	011092	4	Plain washer M8	
⑳	011001	4	Set screw M6 x 16	
㉑	011122	1	Split pin $\frac{3}{16}$ " x $1\frac{1}{2}$ "	

Central brush (wide sweep) dual sweep support slewing arrangement

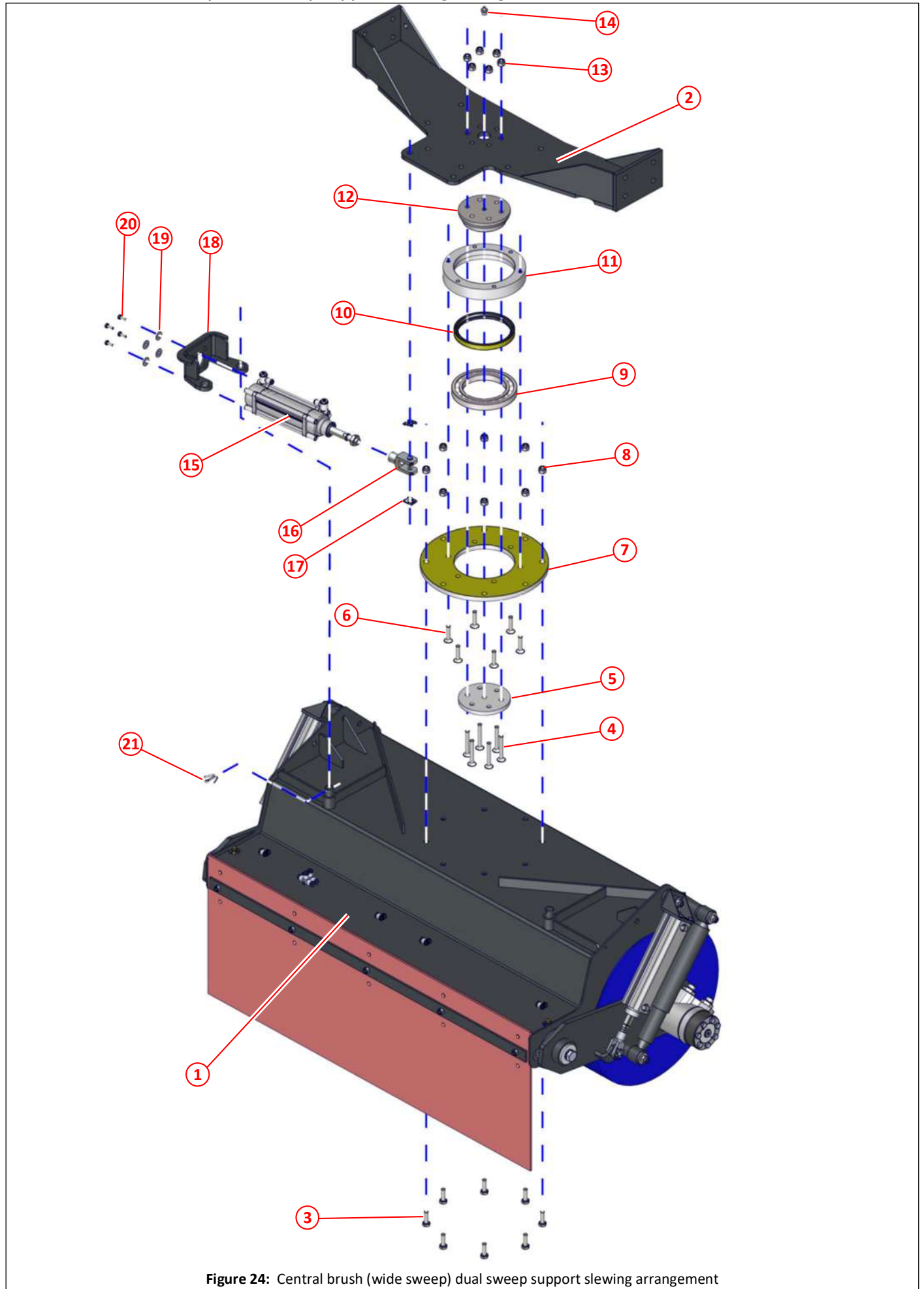

Figure 24: Central brush (wide sweep) dual sweep support slewing arrangement

Central brush (wide sweep) motor end arrangement

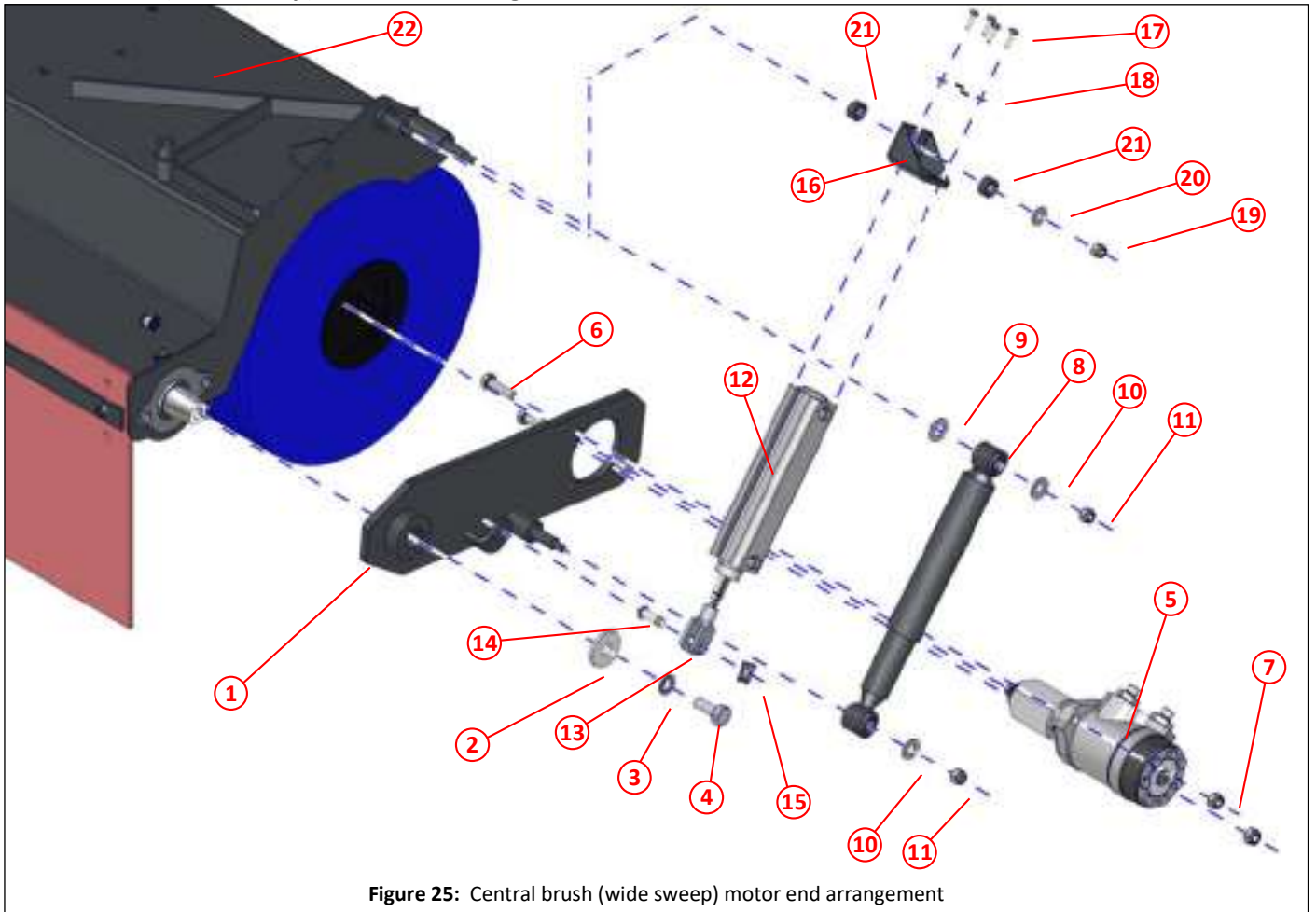

Figure 25: Central brush (wide sweep) motor end arrangement

Item	Part No	Qty	Description	
①	023077	1	Motor plate, left hand	
②	013439	1	Washer, $\phi 16.5 \times \phi 50 \times 5$	
③	011142	1	Spring washer M16	
④	011141	1	Bolt M16 x 35	
⑤			Motor and central brush drive assembly	53
⑥	011069	2	Bolt M12 x 40	
⑦	011077	2	Nyloc nut M12	
⑧	014063	1	Shock absorber 320/500	
⑨	011135	1	Plain washer M16	
⑩	011096	2	Plain washer M12	
⑪	011075	2	Nyloc nut M10	
⑫	020602	1	Pneumatic cylinder 40 x 125	307
⑬	014469	1	Clevis M12	
⑭	023270	1	Clevis pin 12	
⑮	023269	1	Safety fastener 12	
⑯	030532	1	Mounting bracket, pneumatic cylinder, central brush	
⑰	011067	4	Set screw M6 x 20x	
⑱	011091	4	Spring washer M6	
⑲	011075	1	Nyloc nut M10	
⑳	011094	1	Plain washer M10	
㉑	011000	2	Rubber spacer, 11mm long, ( $\frac{5}{8}$ " hose)	
㉒			Central brush (wide sweep)	56

## Central brush (wide sweep) bearing end arrangement

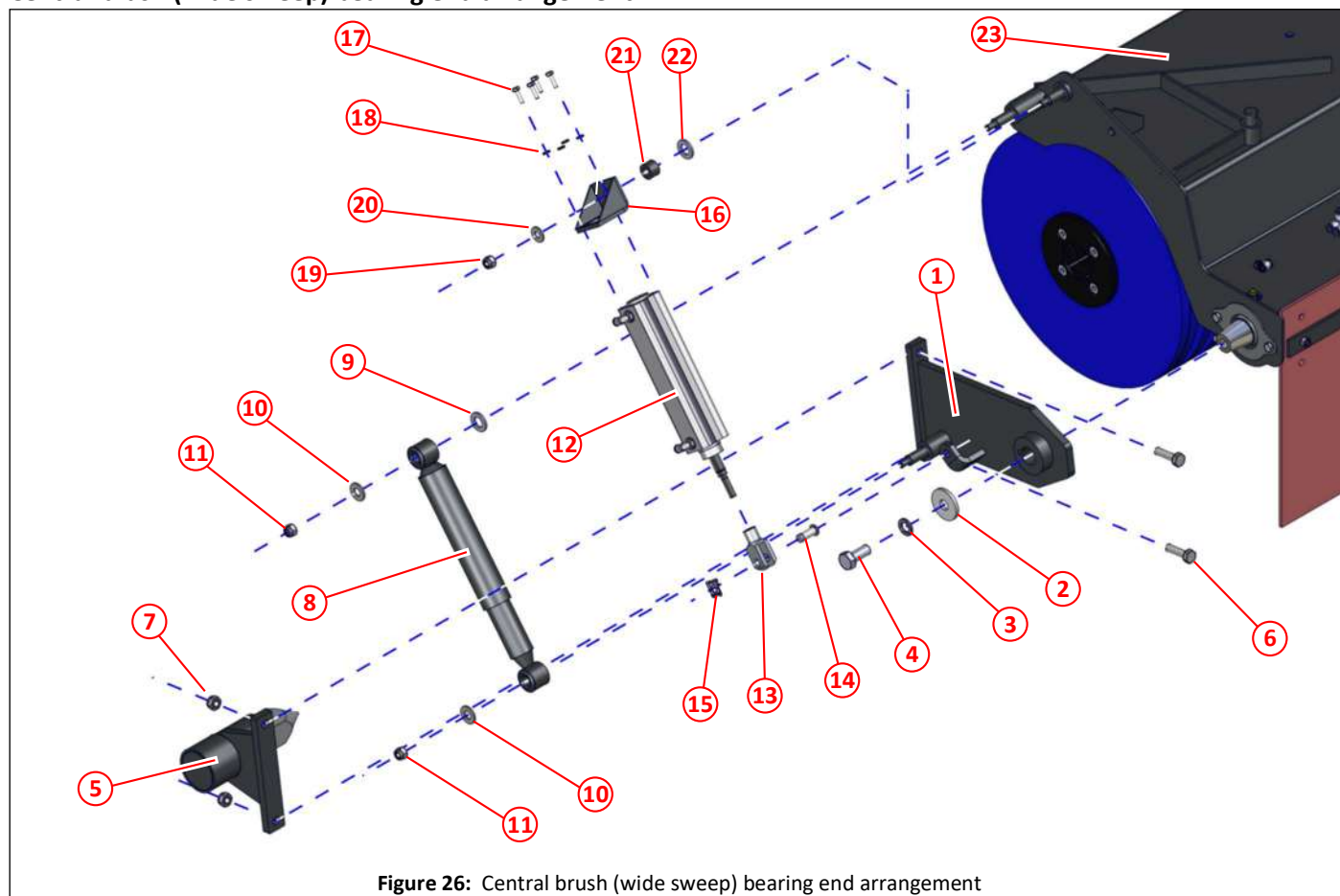

Figure 26: Central brush (wide sweep) bearing end arrangement

Item	Part No	Qty	Description	
①	023078	1	Motor plate, right hand	
②	013439	1	Washer, $\phi 16.5 \times \phi 50 \times 5$	
③	011142	1	Spring washer M16	
④	011141	1	Bolt M16 x 35	
⑤	024224	1	Bearing assembly	54
⑥	011069	2	Bolt M12 x 40	
⑦	011077	2	Nyloc nut M12	
⑧	014063	1	Shock absorber 320/500	
⑨	011135	1	Plain washer M16	
⑩	011096	2	Plain washer M12	
⑪	011075	2	Nyloc nut M10	
⑫	020602	1	Pneumatic cylinder 40 x 125	307
⑬	014469	1	Clevis M12	
⑭	023270	1	Clevis pin 12	
⑮	023269	1	Safety fastener 12	
⑯	030532	1	Mounting bracket, pneumatic cylinder, central brush	
⑰	011067	4	Set screw M6 x 20x	
⑱	011091	4	Spring washer M6	
⑲	011075	1	Nyloc nut M10	
⑳	011094	1	Plain washer M10	
㉑	011000	2	Rubber spacer, 11mm long, ( $\frac{5}{8}$ " hose)	
㉒	011135	1	Plain washer M16	
㉓			Central brush (wide sweep)	56



Central brush (wide sweep) motor arrangement

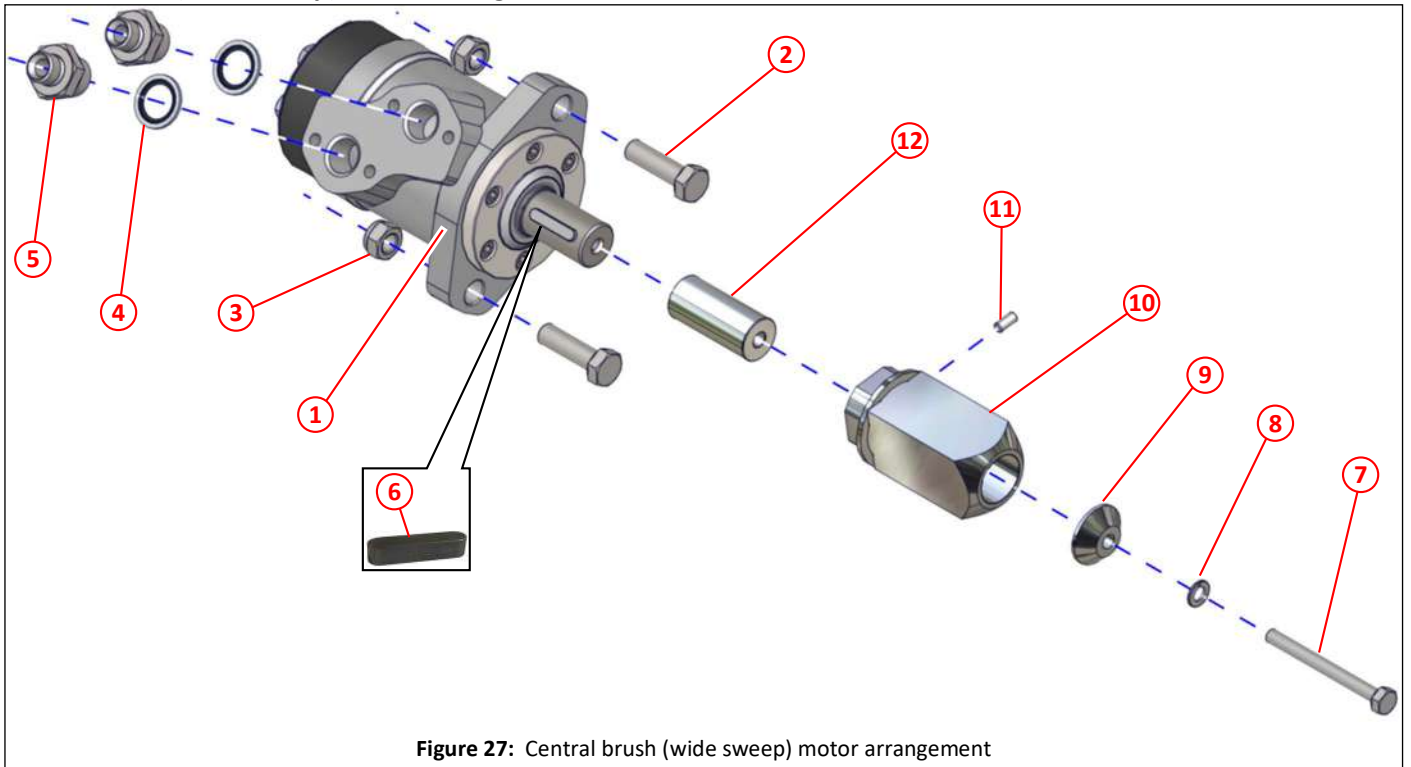

Figure 27: Central brush (wide sweep) motor arrangement

Item	Part No	Qty	Description	
①	010566	1	Motor, 3596 (OMP 100), central brush (wide sweep)	276
②	011069	2	Bolt M12 x 40	
③	011077	2	Nyloc nut M12	
④	011154	2	Dowty seal 1/2" BSP	
⑤	011167	2	Adapter 1/2" x 3/8" BSP	
⑥	011515	1	Key for motor	
⑦	011415	1	Bolt M8 x 80	
⑧	011093	1	Spring washer M8	
⑨	024538	1	Washer cone	
⑩	024535	1	Drive shaft, central brush (wide sweep)	
⑪	011112	1	Socket set screw M6 x 12	
⑫	038106	1	Spacer ø8.5 x ø25 x 55	



## Central brush (wide sweep) bearing arrangement

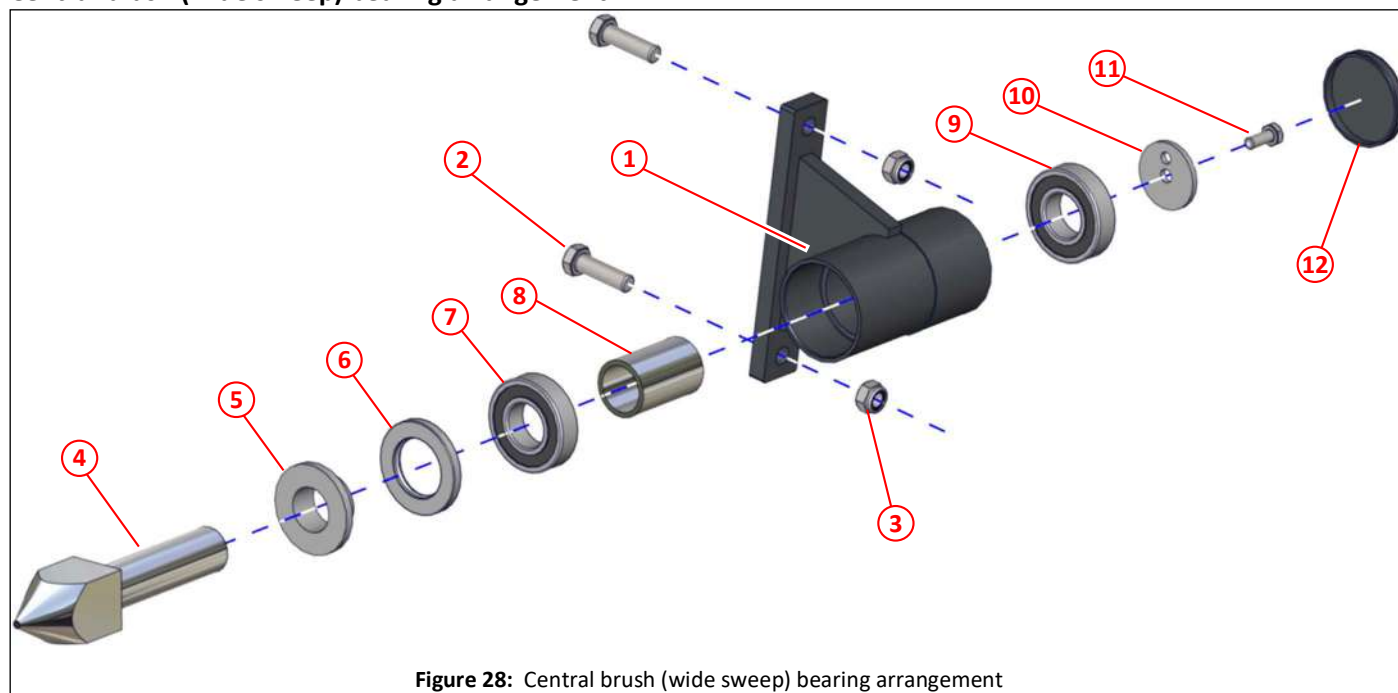

Figure 28: Central brush (wide sweep) bearing arrangement

Item	Part No	Qty	Description
①	024219	1	Bearing housing, central brush (wide sweep)
②	011069	2	Bolt M12 x 40
③	011077	2	Nyloc nut M12
④	024223	1	Shaft, central brush (wide sweep)
⑤	024221	1	Spacer $\varnothing 30 \times \varnothing 60 \times 20$ , special
⑥	024220	1	Oil seal $\varnothing 38 \times \varnothing 62 \times 7$
⑦	010578	1	Bearing, ball, 6206 2Z
⑧	024531	1	Spacer $\varnothing 31 \times \varnothing 38 \times 58$
⑨	010578	1	Bearing, ball, 6206 2Z
⑩	010004	1	Washer $\varnothing 9 \times \varnothing 45 \times 4$
⑪	011010	1	Set screw M8 x 20
⑫	024222	1	Bearing cap, central brush (wide sweep)

Central brush (wide sweep) skirt arrangement

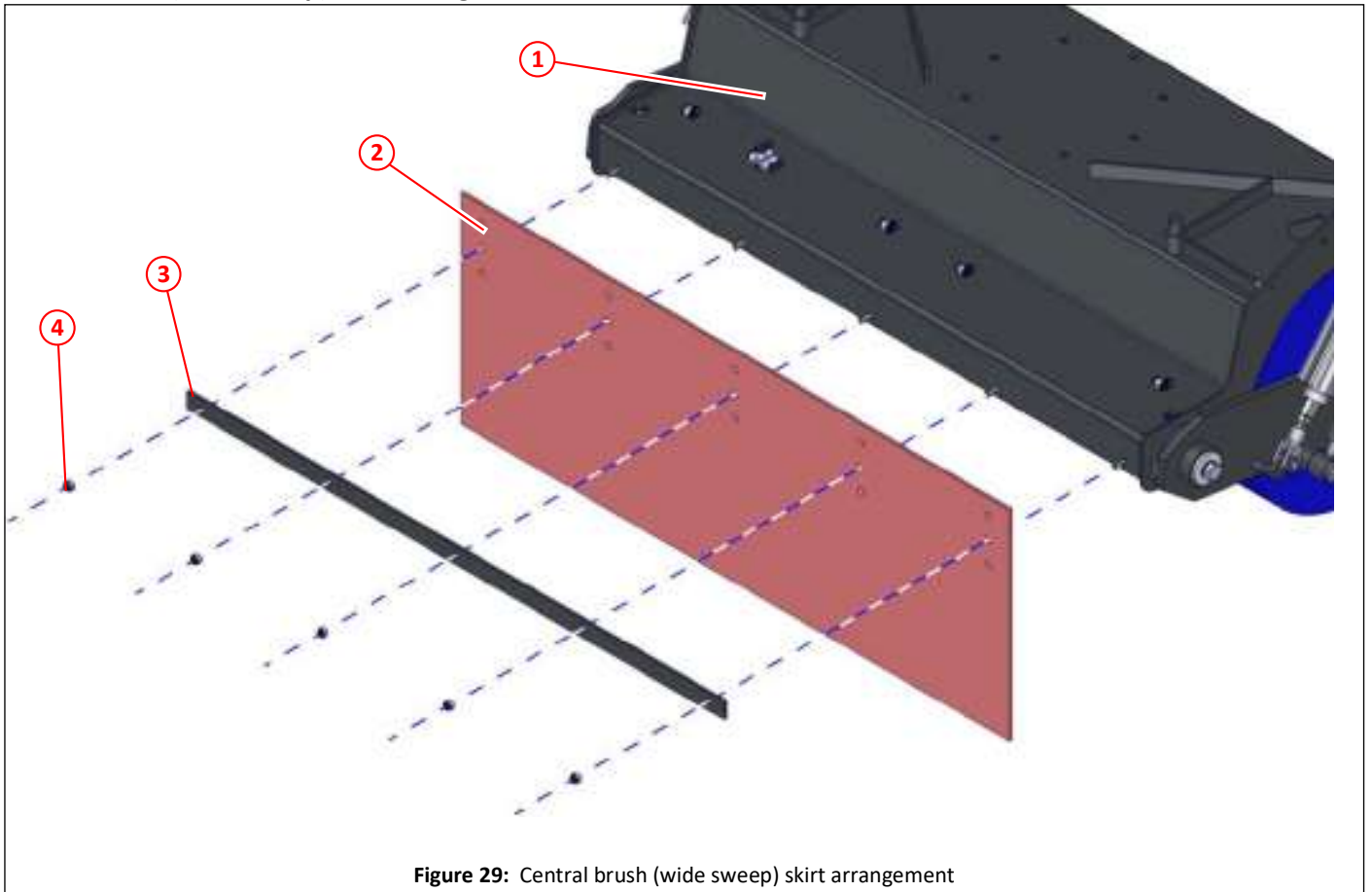

Figure 29: Central brush (wide sweep) skirt arrangement

Item	Part No	Qty	Description	
①			Central brush (wide sweep)	56
②	022516	1	Skirt, central brush (wide sweep)	
③	022517	1	Clamp, skirt, central brush (wide sweep)	
④	011073	5	Nyloc nut M8	

## Central brush (wide sweep) cover and shaft arrangement

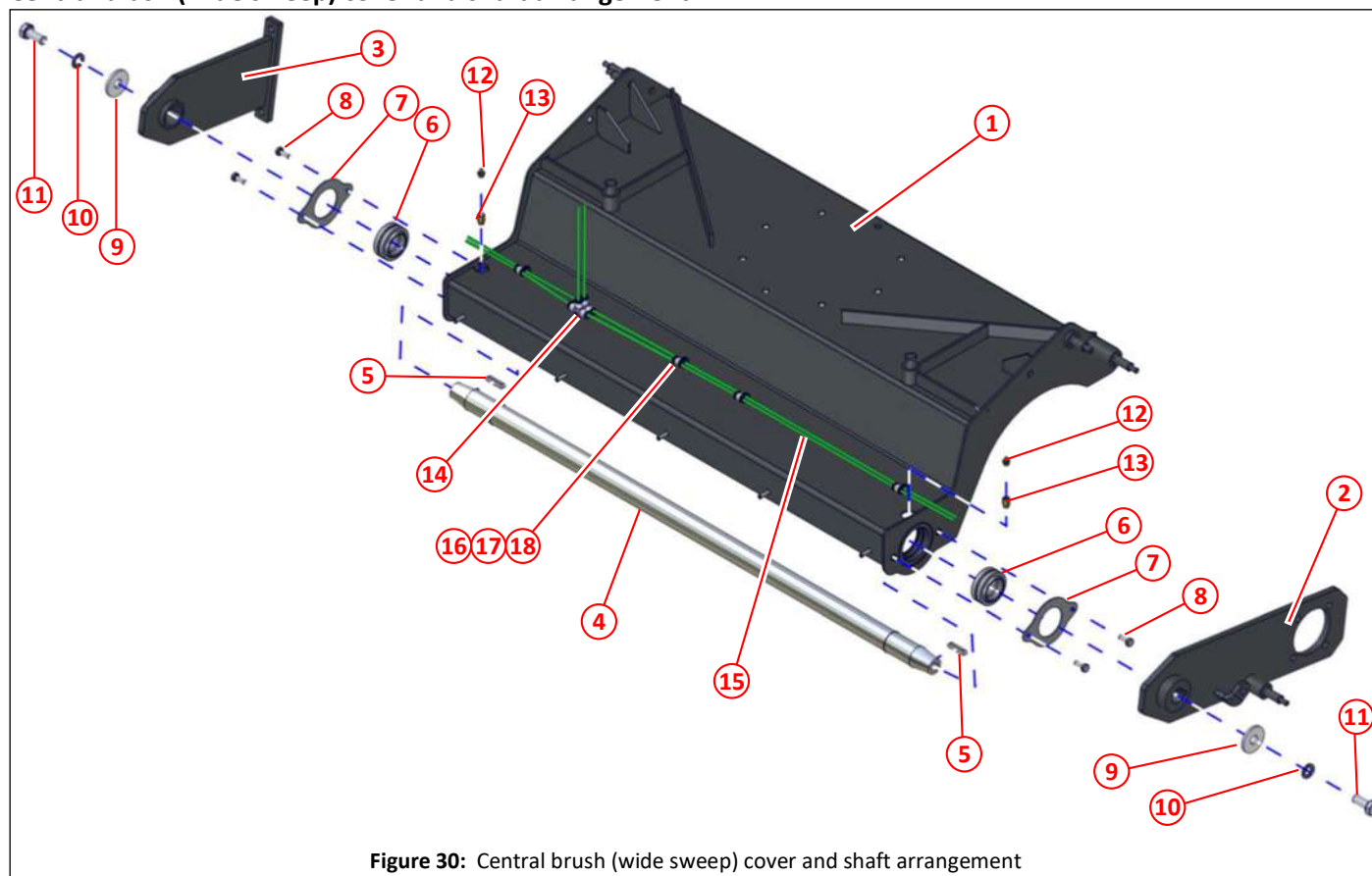

Figure 30: Central brush (wide sweep) cover and shaft arrangement

Item	Part No	Qty	Description
①	036216	1	Cover, central brush (wide sweep)
②	023077	1	Motor plate, left hand
③	023078	1	Motor plate, right hand
④	023080	1	Shaft taper
⑤	013292	2	Key for shaft taper
⑥	036789	2	Spherical bearing
⑦	037172	2	Retaining plate, spherical bearing
⑧	011010	4	Set screw M8 x 20
⑨	013439	2	Washer, $\phi 16.5 \times \phi 50 \times 5$
⑩	011142	2	Spring washer M16
⑪	011141	1	Bolt M16 x 35
⑫	010903	2	Grease nipple, straight, $\frac{1}{8}$ " BSP
⑬	040301	2	Grease nipple extension $\frac{1}{8}$ " BSP
⑭	024647	2	Tee grey, 6mm, (pneumatics)
⑮	024650	As req	Air pipe, $\phi 6$ , green
⑯	021914	4	P-clip $\phi 12$ , rubber sealed
⑰	000234	4	Pan head, Pozidrive, chamfered, set screw M5 x 16, black
⑱	000155	4	Nyloc nut M5

Central brush (wide sweep), brush and brush core arrangement

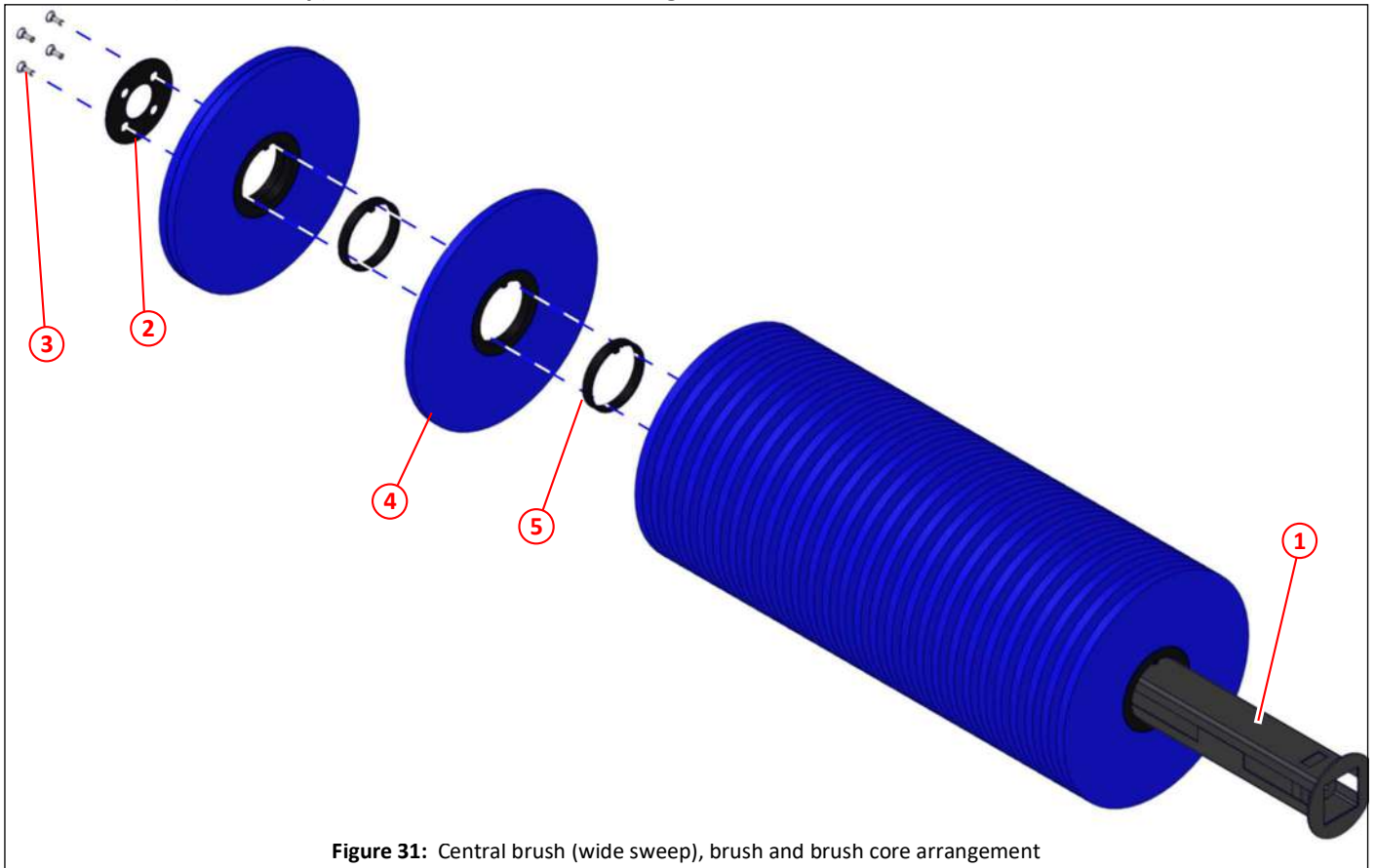
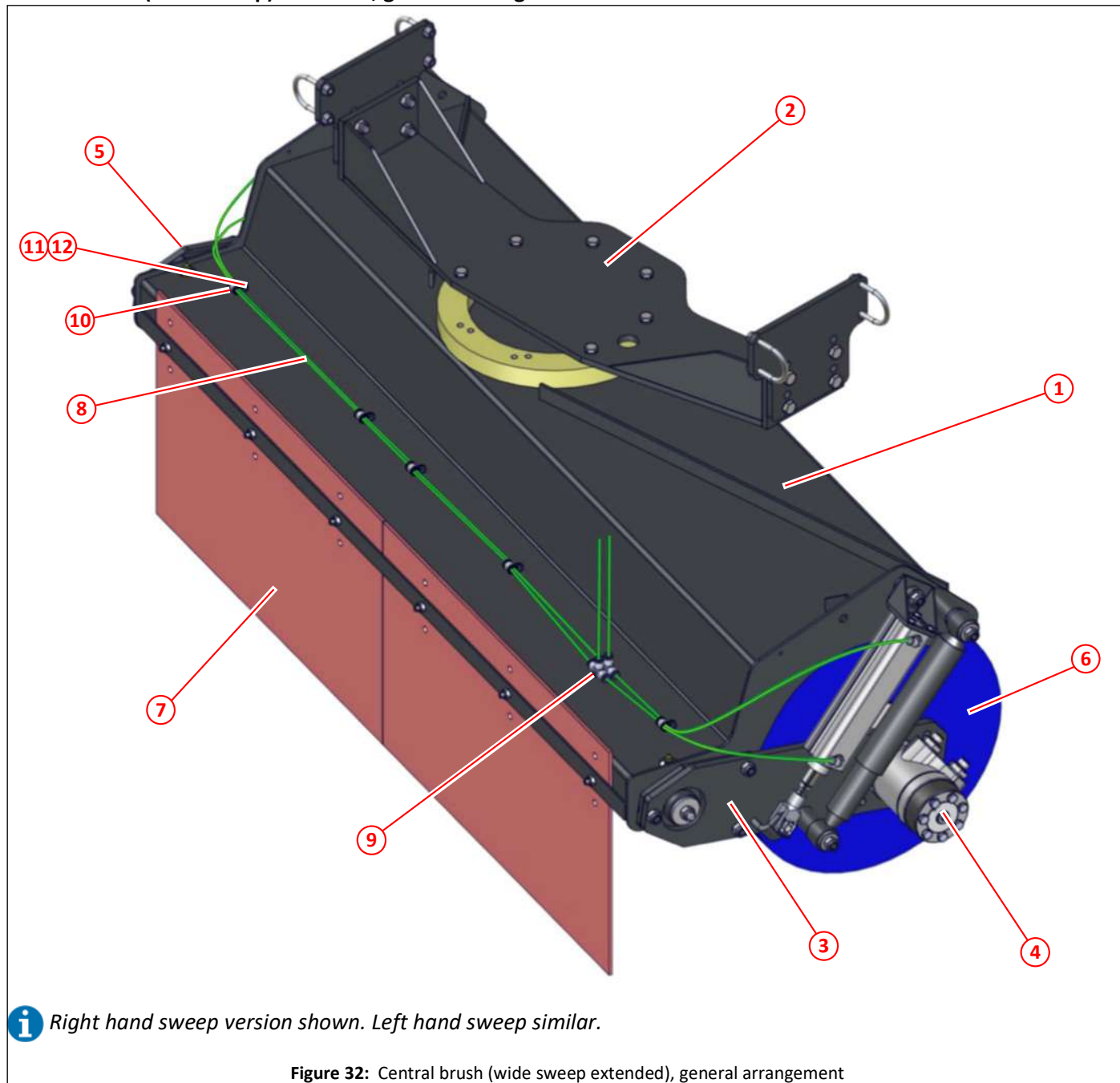

Figure 31: Central brush (wide sweep), brush and brush core arrangement

Item	Part No	Qty	Description	
①	13646	1	Brush core	
②	13649	1	End cap, brush core	
③	011417	4	Socket cap screw $\frac{3}{8}$ " UNC x 1"	
④	023474	31	Brush fill, $\phi$ 400, poly	
⑤	023472	29	Brush spacer	
NI	023474	1	Box of 44 brush fill, $\phi$ 400, poly	
NI	037588	1	Brush core assembly, items ① to ⑤	

Central brush (wide sweep) extended, general arrangement



**i** Right hand sweep version shown. Left hand sweep similar.

Figure 32: Central brush (wide sweep extended), general arrangement

Item	Part No	Qty	Description	
①	037176	1	Cover, central brush (wide sweep) extended 1300 wide, right hand sweep	65
NI	037174	1	Cover, central brush (wide sweep) extended 1300 wide, left hand sweep	65
②	020516	1	Bracket, wide sweep support	
③		1	Motor end assembly	60
④		1	Motor assembly	62
⑤		1	Bearing end assembly	61
⑥		1	Central brush (wide sweep) and brush core extended assembly	66
⑦			Skirt, central brush (wide sweep) extended	64
⑧	024650	As req	Air pipe, ø6, green	
⑨	024647	2	Tee grey, 6mm, (pneumatics)	
⑩	021914	5	P-clip ø12, rubber sealed	
⑪	000234	5	Pan head, Pozidrive, chamfered, set screw M5 x 16, black	
⑫	000155	5	Nyloc nut M5	

Central brush (wide sweep) extended, support

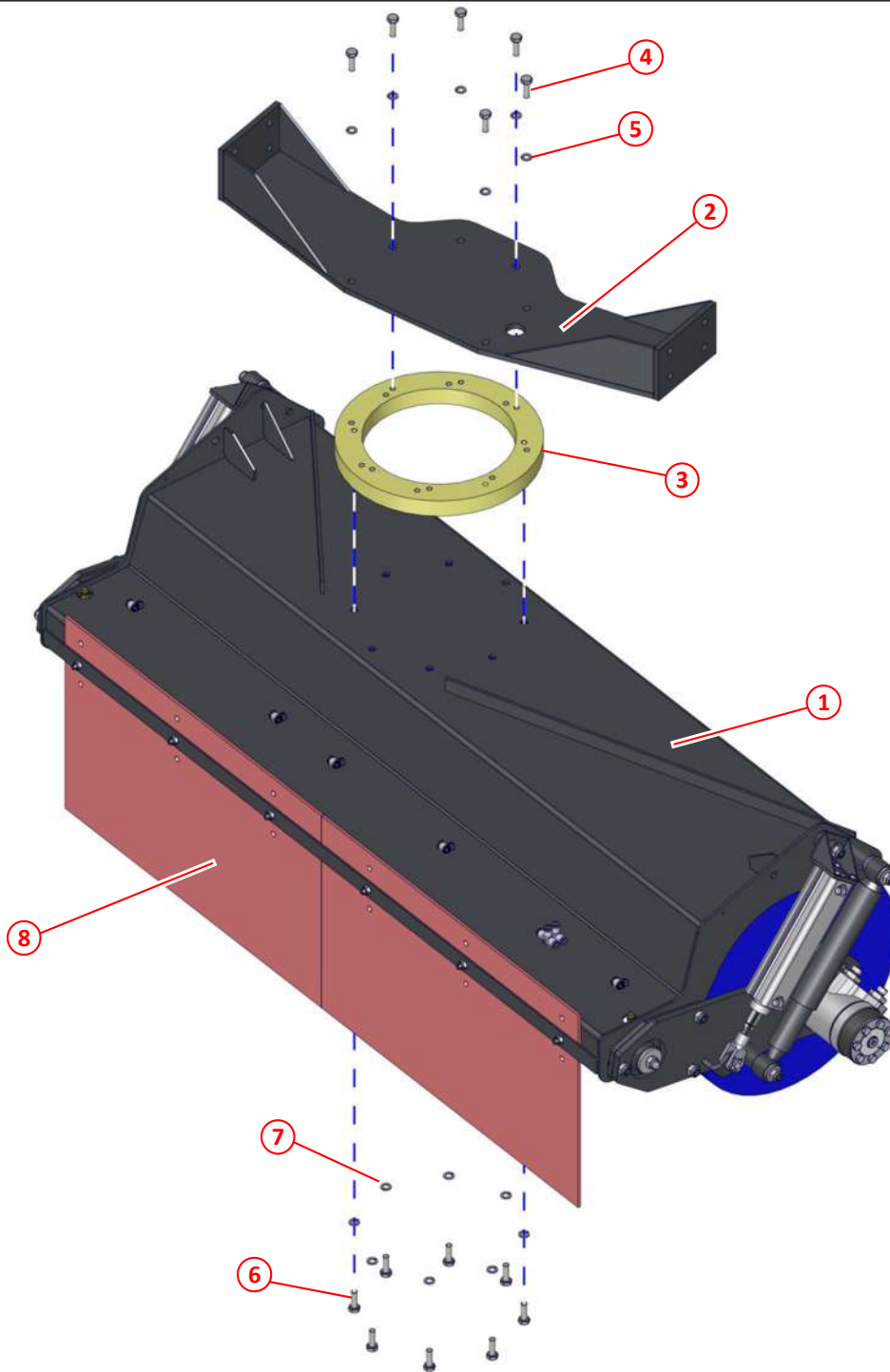

**i** Right hand sweep version shown. Left hand sweep similar.

Figure 33: Central brush (wide sweep) Extended, support

Item	Part No	Qty	Description	
①			Central brush (wide sweep) extended	58,65
②	020516	1	Bracket, wide sweep support	
③	020919	1	Adapter ring, fixed slew	
④	011032	6	Set screw M10 x 30	
⑤	011095	6	Spring washer M10	
⑥	011032	8	Set screw M10 x 30	
⑦	011095	8	Spring washer M10	
			Skirt, central brush (wide sweep) extended	64



## Central brush (wide sweep) extended, motor end arrangement

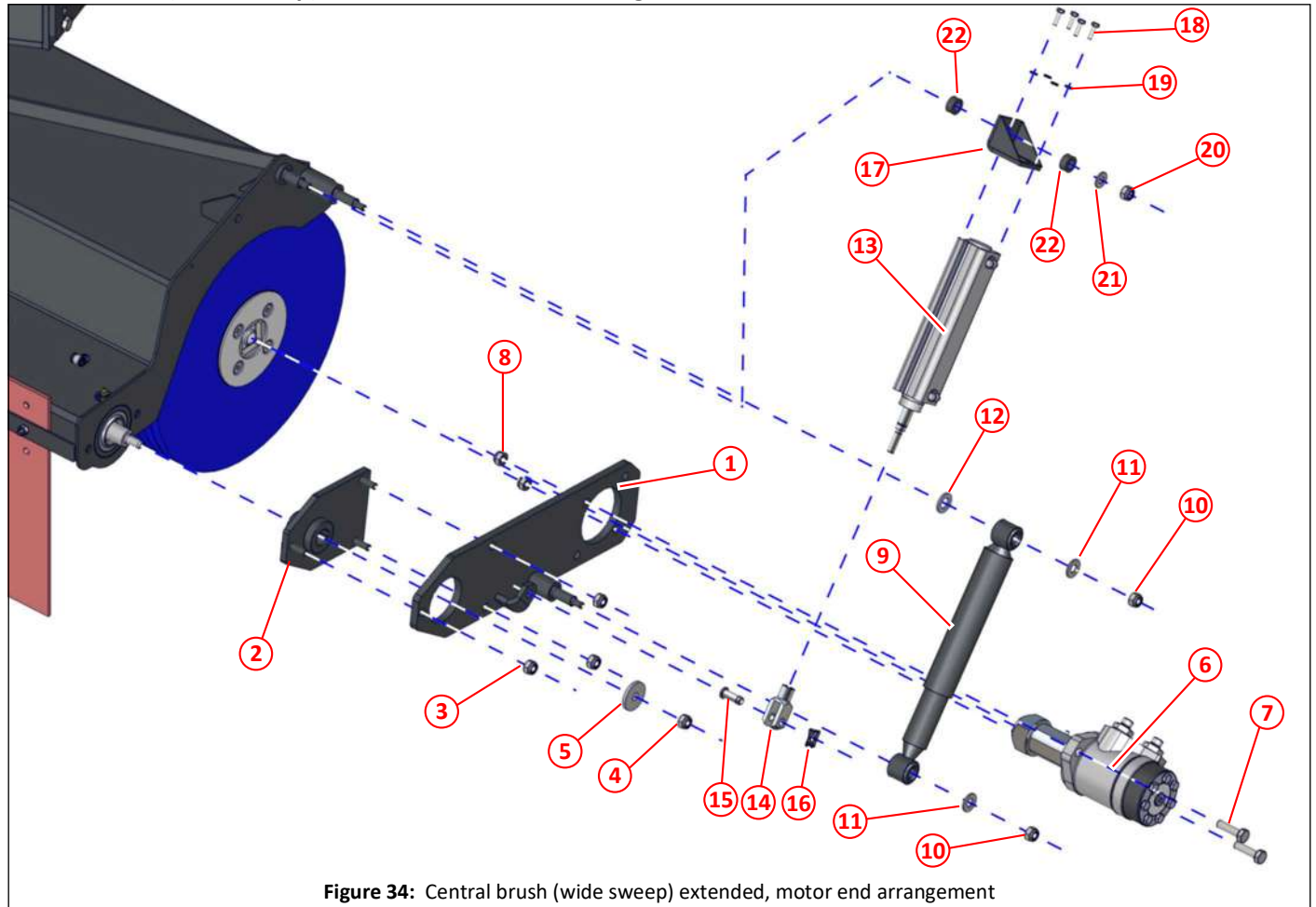

Figure 34: Central brush (wide sweep) extended, motor end arrangement

Item	Part No	Qty	Description	
①	022401	1	Motor plate, left side	
②	020727	1	Flange	
③	011075	3	Nyloc nut M10	
④	011077	1	Nyloc nut M12	
⑤	020707	1	Washer $\phi 12.5 \times \phi 44 \times 5$	
⑥			Motor assembly	62
⑦	011069	2	Bolt M12 x 40	
⑧	011077	1	Nyloc nut M12	
⑨	014063	1	Shock absorber	
⑩	011075	2	Nyloc nut M10	
⑪	011096	2	Plain washer M12	
⑫	011135	1	Plain washer M16	
⑬	020602	1	Pneumatic cylinder 40 x 125	307
⑭	014469	1	Clevis M12	
⑮	023270	1	Clevis pin 12	
⑯	023269	1	Safety fastener 12	
⑰	030532	1	Mounting bracket, pneumatic cylinder, central brush	
⑱	011067	4	Set screw M6 x 20x	
⑲	011091	4	Spring washer M6	
⑳	011075	1	Nyloc nut M10	
㉑	011094	1	Plain washer M10	
㉒	011000	2	Rubber spacer, 11mm long, ( $\frac{5}{8}$ " hose)	



Central brush (wide sweep) extended, bearing end arrangement

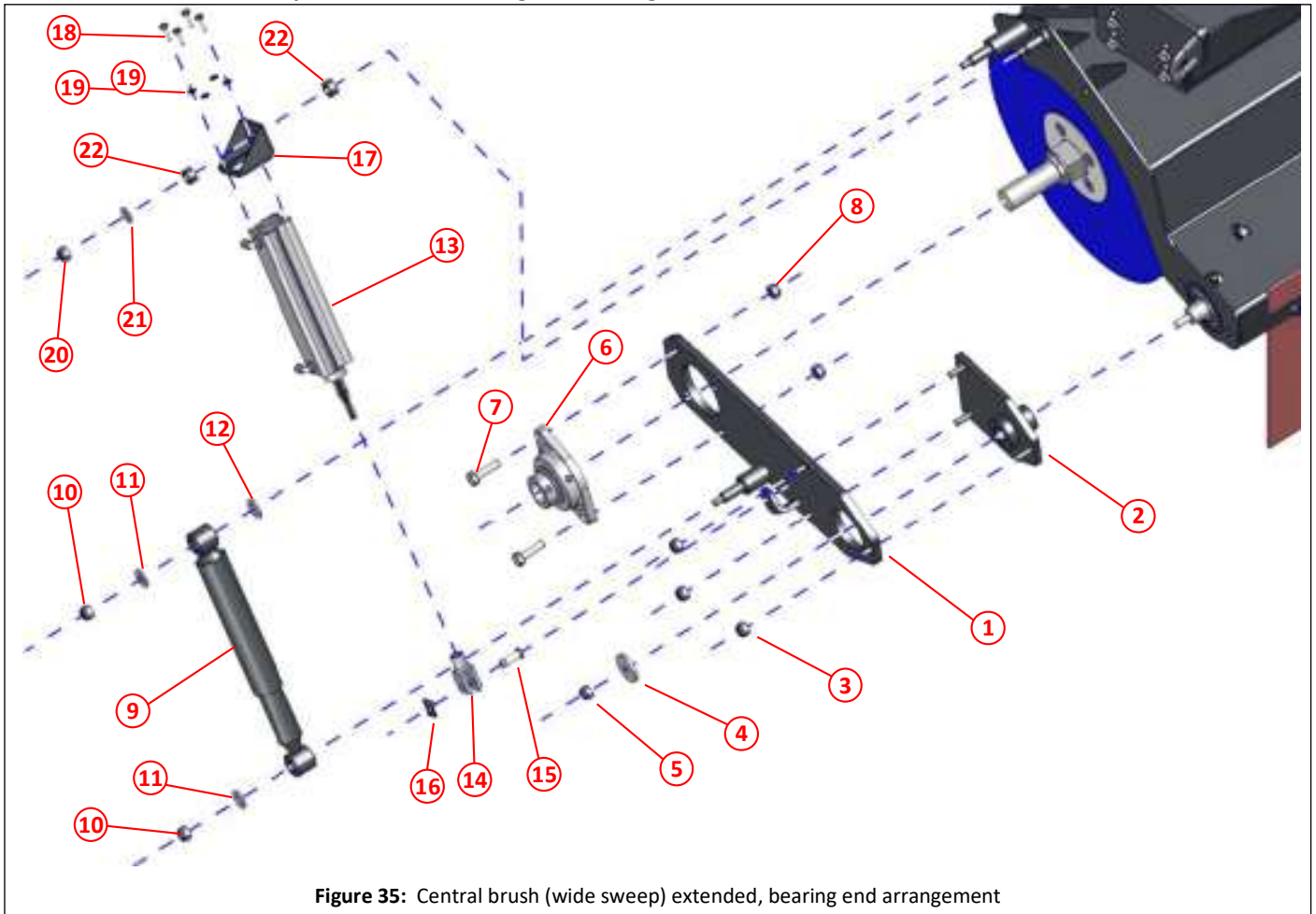

Figure 35: Central brush (wide sweep) extended, bearing end arrangement

Item	Part No	Qty	Description	
①	022400	1	Motor plate, right side	
②	020727	1	Flange	
③	011075	3	Nyloc nut M10	
④	011077	1	Nyloc nut M12	
⑤	020707	1	Washer $\phi 12.5 \times \phi 44 \times 5$	
⑥	010612	1	Bearing, extended central brush (wide sweep)	
⑦	011069	2	Bolt M12 x 40	
⑧	011077	1	Nyloc nut M12	
⑨	014063	1	Shock absorber	
⑩	011075	2	Nyloc nut M10	
⑪	011096	2	Plain washer M12	
⑫	011135	1	Plain washer M16	
⑬	020602	1	Pneumatic cylinder 40 x 125	307
⑭	014469	1	Clevis M12	
⑮	023270	1	Clevis pin 12	
⑯	023269	1	Safety fastener 12	
⑰	030532	1	Mounting bracket, pneumatic cylinder, central brush	
⑱	011067	4	Set screw M6 x 20x	
⑲	011091	4	Spring washer M6	
⑳	011075	1	Nyloc nut M10	
㉑	011094	1	Plain washer M10	
㉒	011000	2	Rubber spacer, 11mm long, ( $\frac{5}{8}$ " hose)	

Central brush (wide sweep) extended, motor arrangement

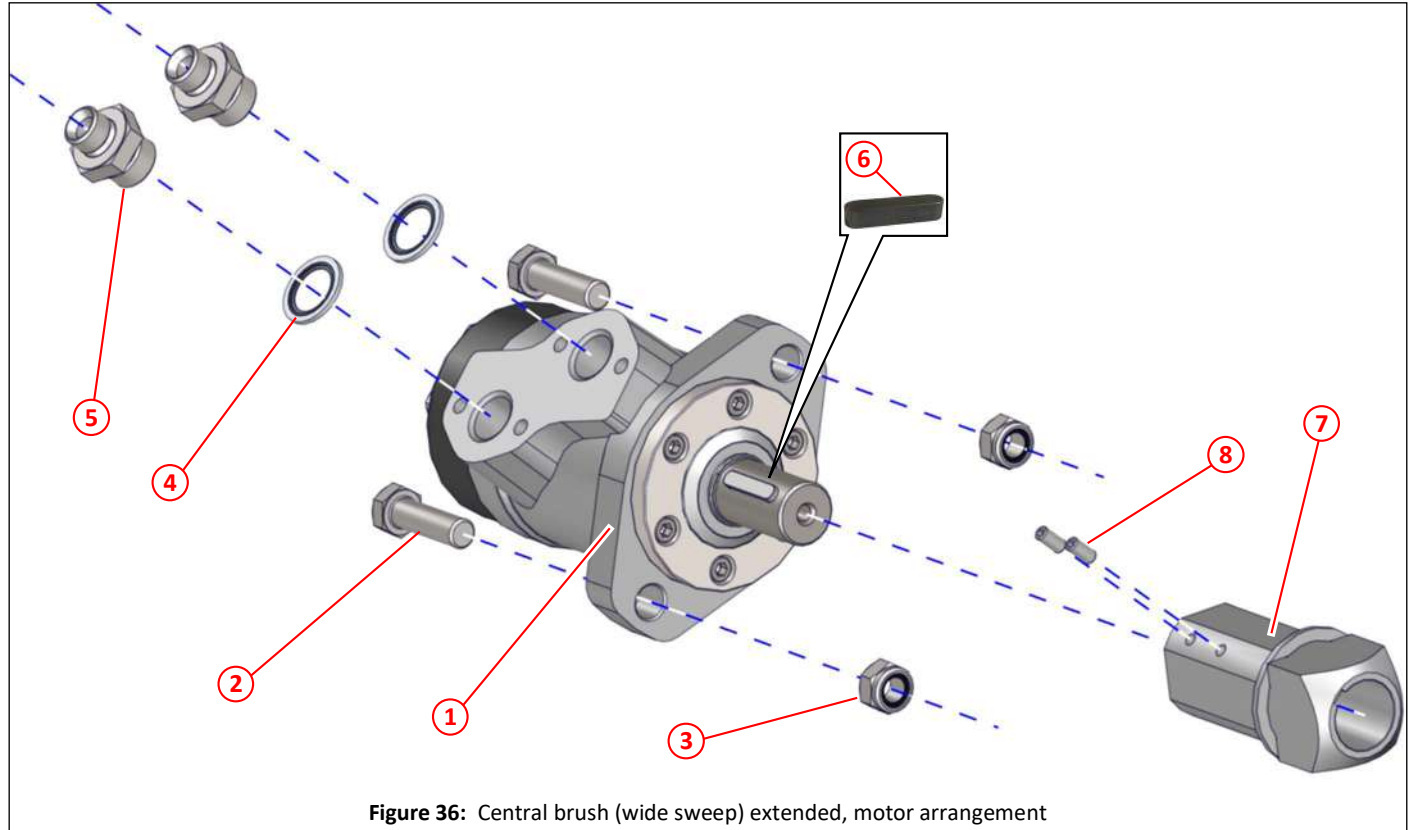

Figure 36: Central brush (wide sweep) extended, motor arrangement

Item	Part No	Qty	Description	
①	010566	1	Motor 3596 (OMP 100)	53, 276
②	011069	2	Bolt M12 x 40	
③	011077	2	Nyloc nut M12	
④	011154	2	Dowty seal $\frac{1}{2}$ " BSP	
⑤	011167	2	Adapter $1\frac{1}{2}$ " x $\frac{3}{8}$ " BSP	
⑥	011515	1	Key for motor	
⑦	013648	1	Drive shaft	
⑧	011112	2	Socket set screw M6 x 12	

Central brush (wide sweep) extended, bearing arrangement

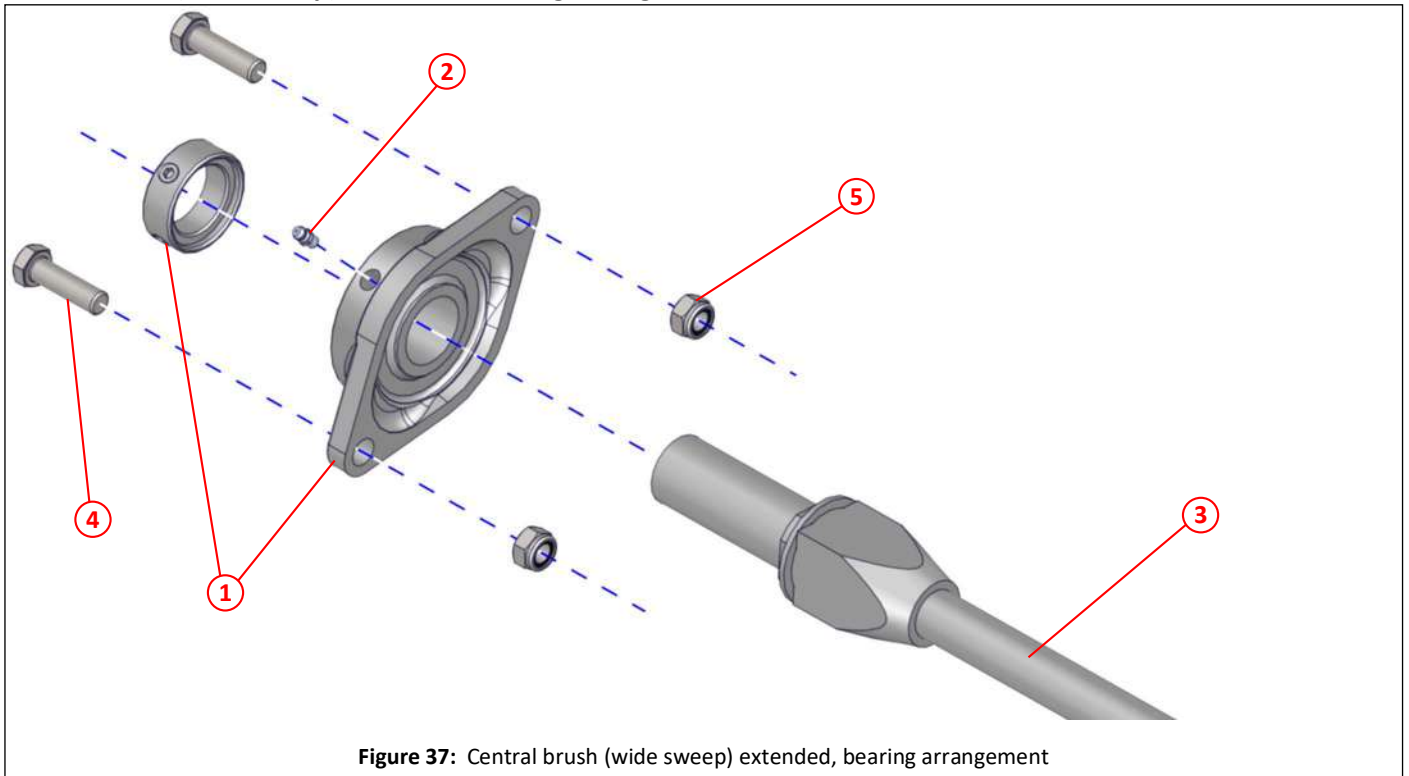

Figure 37: Central brush (wide sweep) extended, bearing arrangement

Item	Part No	Qty	Description	
①	010612	1	Bearing, central brush (wide sweep) extended. Includes locking collar and item ②	
②	043059	1	Grease nipple M6 Straight	
③	021296	1	Drive tube extended	
④	011069	2	Bolt M12 x 40	
⑤	011077	2	Nyloc nut M12	

Central brush (wide sweep) extended, skirt arrangement

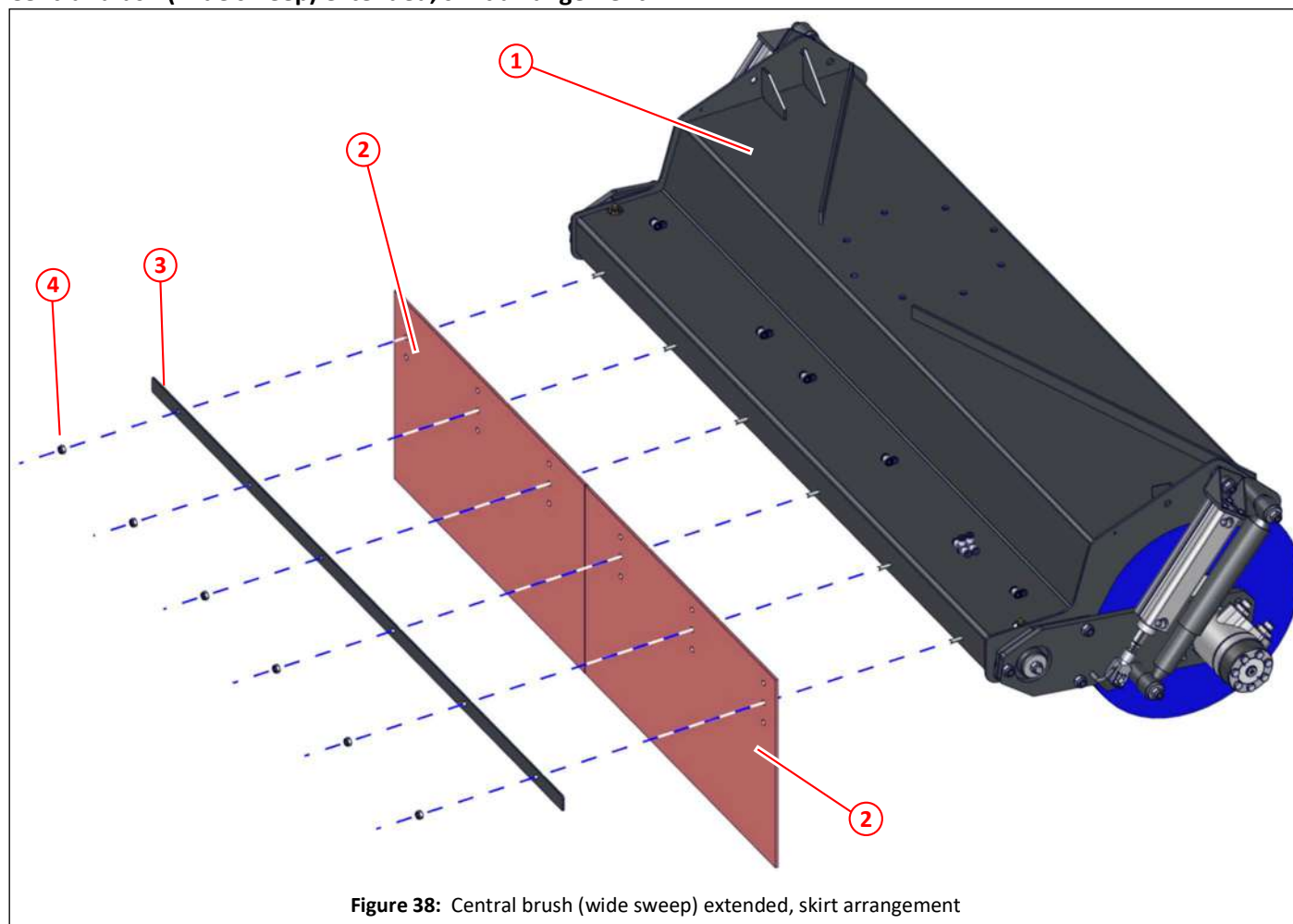
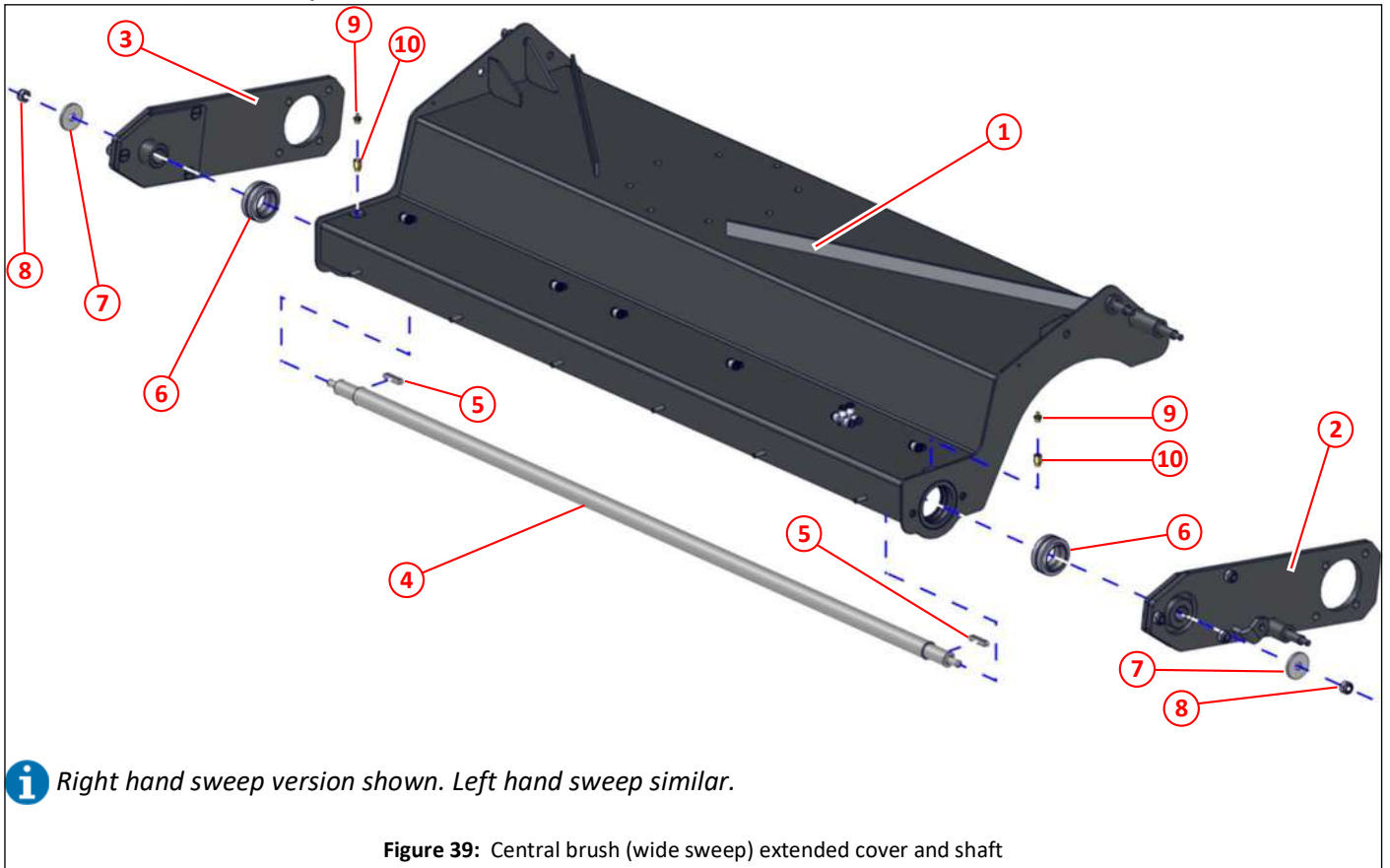

Figure 38: Central brush (wide sweep) extended, skirt arrangement

Item	Part No	Qty	Description	
①			Central brush (wide sweep) extended	58,65
②	022516	2	Skirt, central brush (wide sweep)	
③	024059	1	Clamp, skirt, central brush (wide sweep) extended	
④	011073	6	Nyloc nut M8	

Central brush (wide sweep) extended cover and shaft



Item	Part No	Qty	Description
①	037176	1	Cover, central brush (wide sweep) extended 1300 wide, right hand sweep
NI	037174	1	Cover, central brush (wide sweep) extended 1300 wide, left hand sweep
②	022401	1	Motor plate, left side
③	022400	1	Motor plate, right side
④	024015	1	Shaft, central brush (wide sweep) extended 1300 wide
⑤	013292	2	Key for shaft
⑥	036789	2	Spherical bearing
⑦	020707	1	Washer $\phi 12.5 \times \phi 44 \times 5$
⑧	011077	1	Nyloc nut M12
⑨	010903	2	Grease nipple, straight, $\frac{1}{8}$ " BSP
⑩	040301	2	Grease nipple extension $\frac{1}{8}$ " BSP
⑪	021914	5	P-clip $\phi 12$ , rubber sealed
⑫	000234	5	Pan head, Pozidrive, chamfered, set screw M5 x 16, black
⑬	000155	5	Nyloc nut M5

Central brush (wide sweep) extended, brush core and shaft

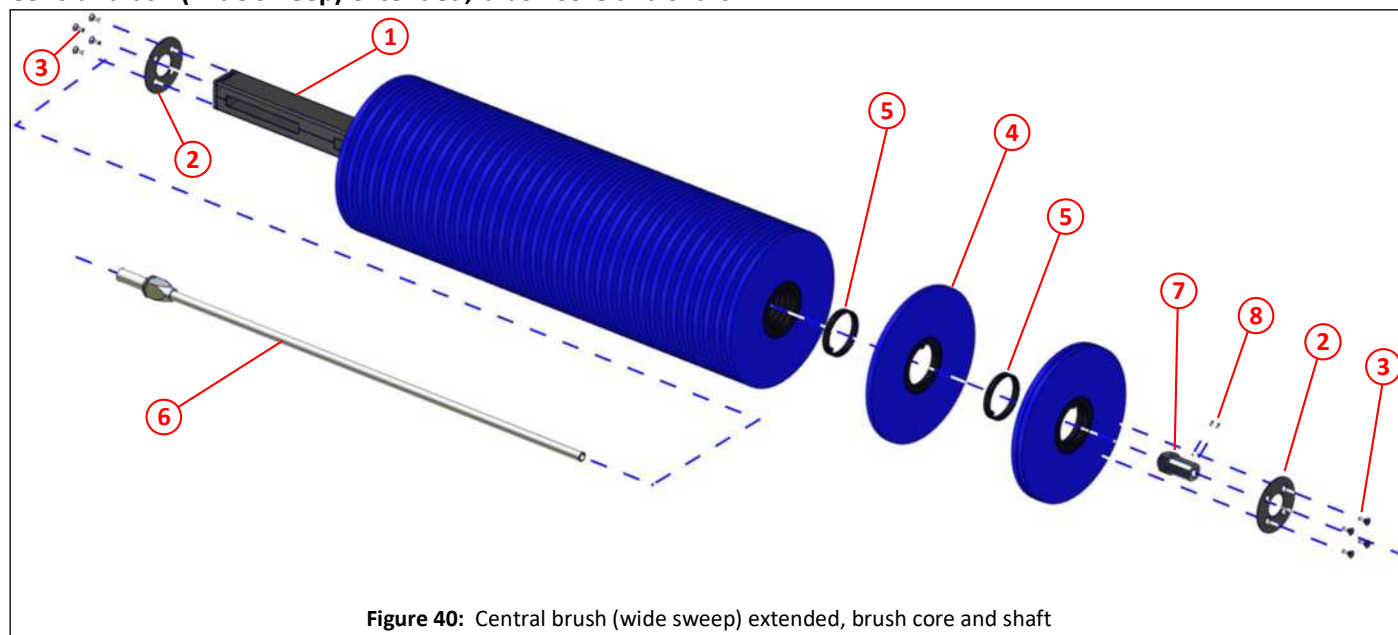
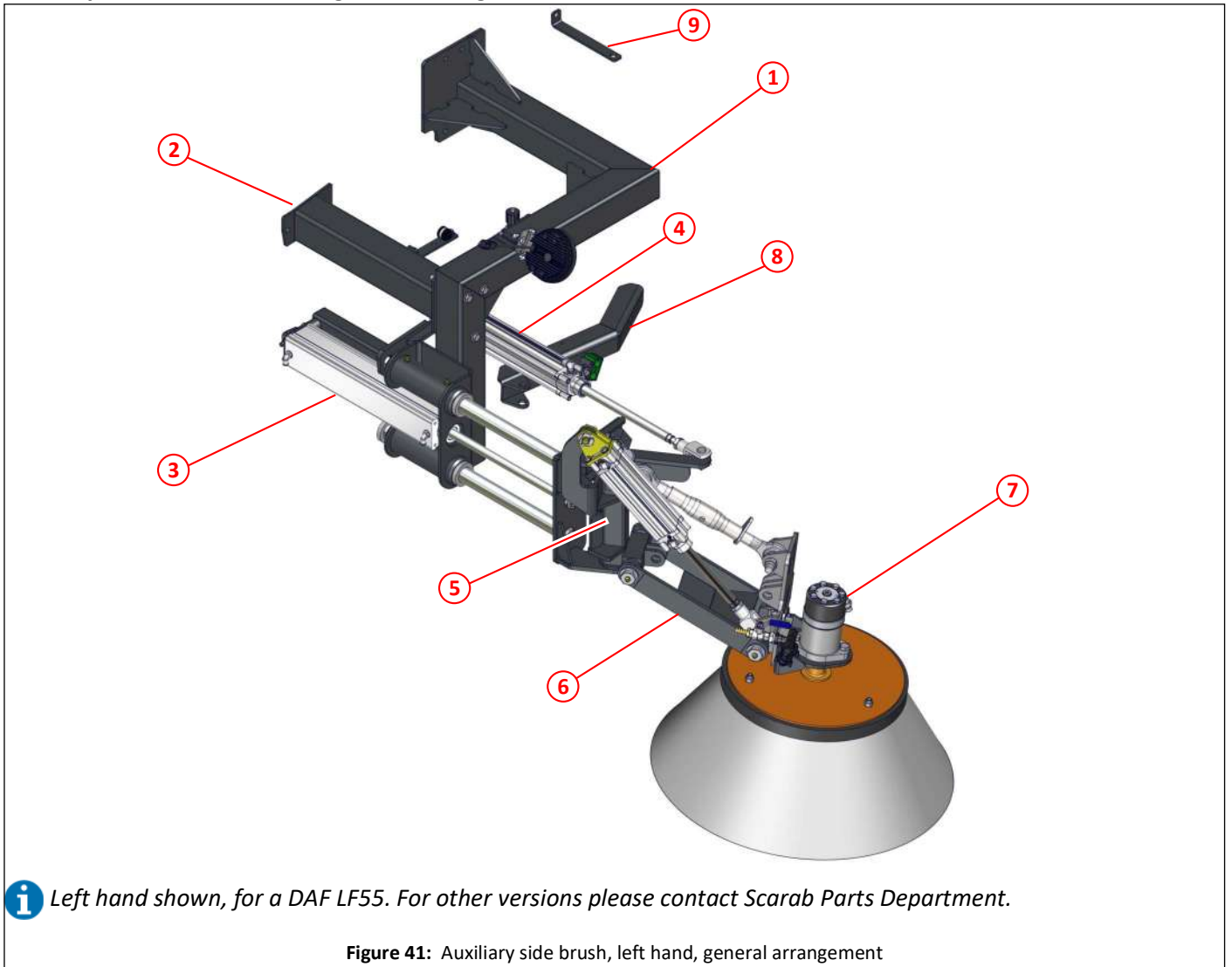

Figure 40: Central brush (wide sweep) extended, brush core and shaft

Item	Part No	Qty	Description
①	021295	1	Brush core, extended
②	013649	2	End cap, brush core
③	011417	8	Socket cap screw $\frac{3}{8}$ " UNC x 1"
④	023474	40	Brush fill, $\varnothing$ 400, poly
⑤	023472	38	Brush spacer
⑥	021296	1	Drive tube extended
⑦	013648	1	Drive shaft, central brush (wide sweep) extended
⑧	011112	2	Socket set screw M6 x 12
NI	023474	1	Box of 44 brush fill, $\varnothing$ 400, poly
NI	024553	1	Brush core assembly complete, items ①, ②, ③, ④ and ⑤



Auxiliary side brush, left hand, general arrangement



Item	Part No	Qty	Description	
①	042197	1	Carrier, auxiliary brush, left hand, (DAF LF55)	68
②	042198	1	Support, auxiliary brush, left hand, (DAF LF55)	68
③		1	Pneumatic cylinder, auxiliary brush extend/retract	69
④		1	Pneumatic cylinder, auxiliary brush swing in/out	70
⑤	037915	1	King post, left hand, auxiliary brush	71
⑥		1	Auxiliary brush linkage, left hand	72
⑦		1	Auxiliary brush, motor and brush assembly	73
⑧	037912	1	Arm, left hand, pneumatic cylinder, replaces item ③ on page 29	29
⑨	013192	1	Bracket, pipe/hose support	

Auxiliary side brush, left hand, carrier

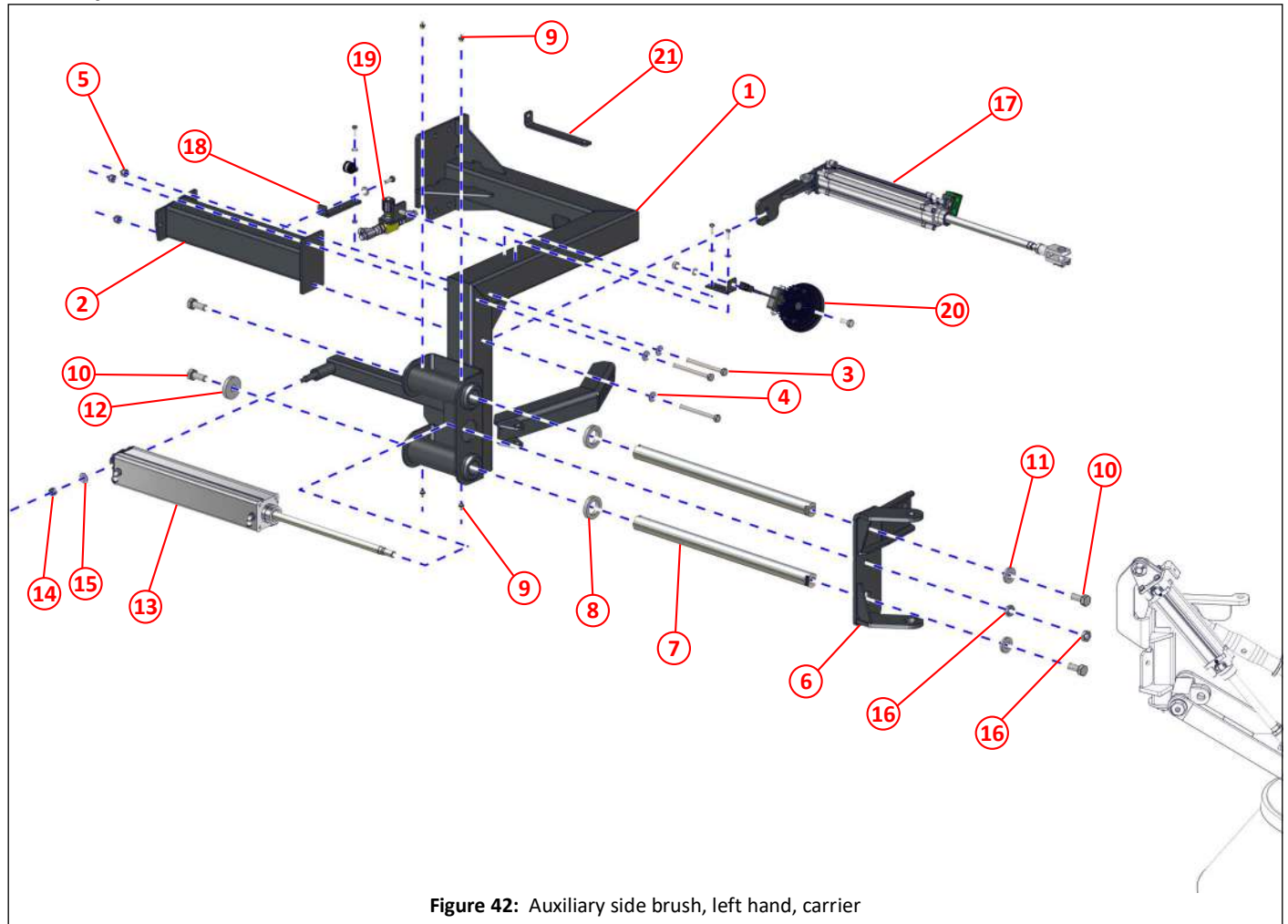

Figure 42: Auxiliary side brush, left hand, carrier

Item	Part No	Qty	Description	
①	042197	1	Carrier, auxiliary brush, left hand, (DAF LF55)	67
②	042198	1	Support, auxiliary brush, left hand (DAF LF55)	
③	011042	3	Bolt M10 x 110	
④	011094	3	Plain washer M10	
⑤	011075	3	Nyloc nut M10	
⑥	037916	1	King post support, left hand auxiliary brush	
⑦	030856	2	Thrust bar, auxiliary brush	
⑧	039838	2	Spacer, auxiliary brush, linear slide	
⑨	010903	4	Grease nipple, 1/8" BSP, straight	
⑩	011141	4	Bolt M16 x 35	
⑪	030862	2	Washer, small, auxiliary brush	
⑫	030861	1	Washer, large, auxiliary brush	
⑬		1	Pneumatic cylinder, auxiliary brush extend/retract	69
⑭	011075	1	Nyloc nut M10	
⑮	011094	1	Plain washer M10	
⑯	000138	2	Lock nut, M16 x 1.5	
⑰		1	Pneumatic cylinder, left hand, swing in/out	70
⑱		1	Bracket, hose support	75
⑲		1	Valve, brush speed	76
⑳		1	Work light, auxiliary brush	77
㉑	013192	1	Bracket, pipe/hose support	

Auxiliary side brush, pneumatic cylinder, extend/retract

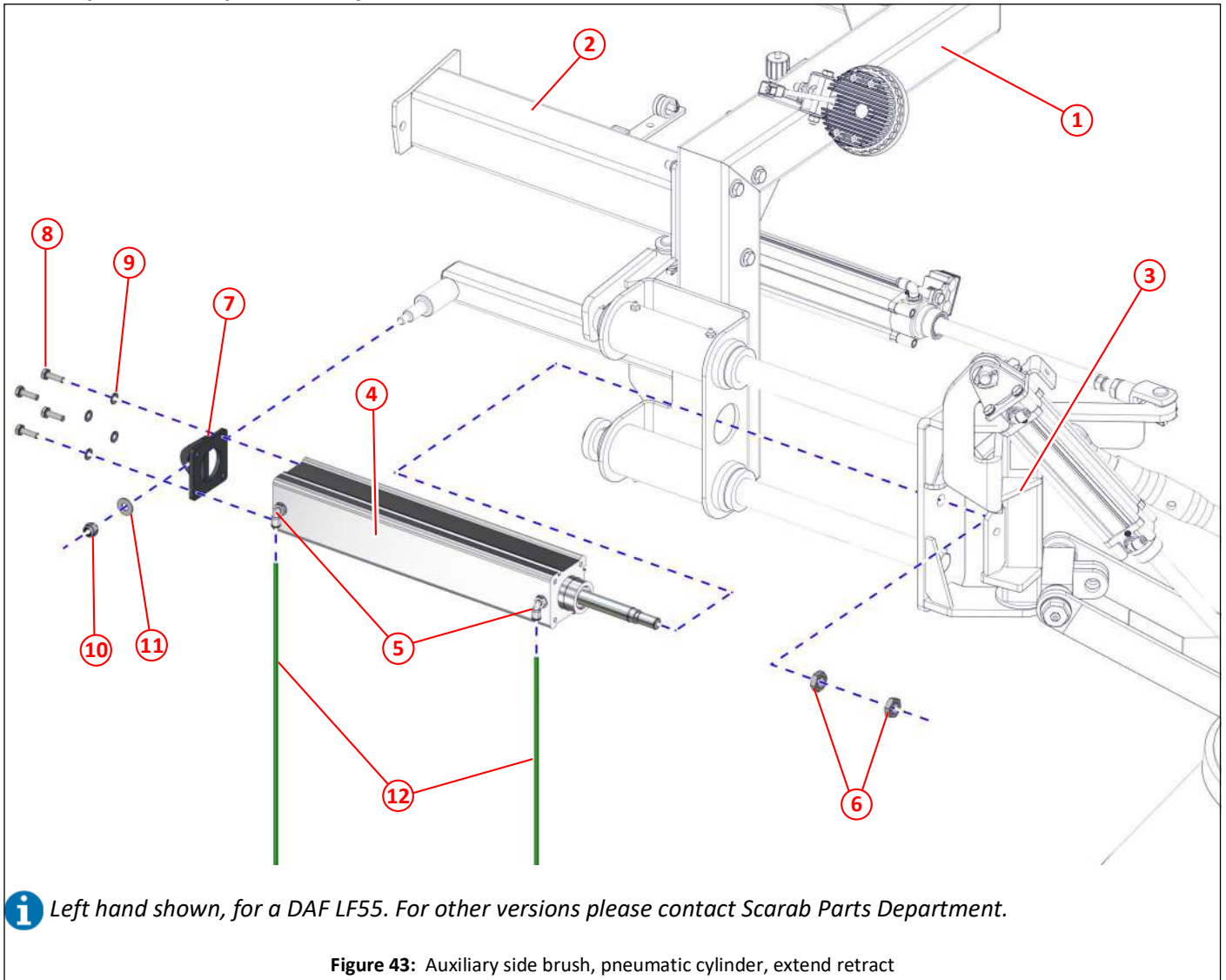
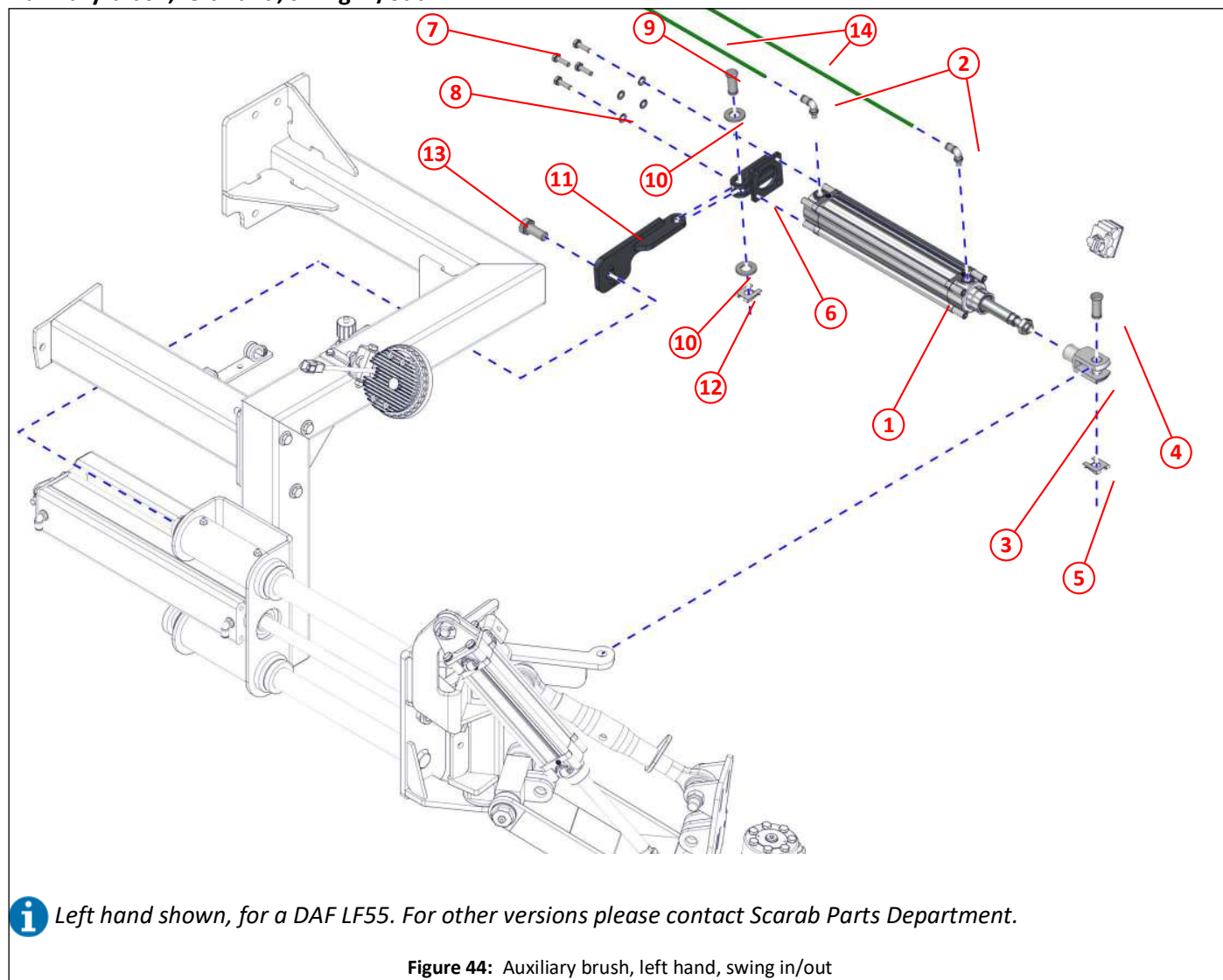

Figure 43: Auxiliary side brush, pneumatic cylinder, extend retract

Item	Part No	Qty	Description	
①	042197	1	Carrier, auxiliary brush, left hand, (DAF LF55)	67,68
②	042198	1	Support, auxiliary brush, left hand (DAF LF55)	67,68
③		1	Auxiliary brush king post, linkage and brush assembly, left hand	71,72,73
④	026396	1	Pneumatic cylinder 63 x 320	315
⑤	024646	2	Elbow, M/F, 1/4" BSP x ø6 push in	
⑥	000138	2	Lock nut M16 x 1.5	
⑦	030859	1	Mounting bracket, pneumatic cylinder, auxiliary brush extend/retract	
⑧	011011	4	Set screw M8 x 25	
⑨	011093	4	Spring washer M8	
⑩	011075	1	Nyloc nut M10	
⑪	011094	1	Plain washer M10	
⑫	024650	As req	Air pipe, green, ø6	

## Auxiliary brush, left hand, swing in/out



**i** Left hand shown, for a DAF LF55. For other versions please contact Scarab Parts Department.

Figure 44: Auxiliary brush, left hand, swing in/out

Item	Part No	Qty	Description	
①	021521	1	Pneumatic cylinder 50 x 160	314
②	024646	2	Elbow, M/F, 1/4" BSP x ø6 push in	
③	020299	1	Clevis M16 x 1.5	
④	022673	1	Clevis pin	
⑤	022674	1	Safety fastener ø16	
⑥	030860	1	Mounting bracket, left hand, pneumatic cylinder, auxiliary brush, swing in/out	
⑦	011011	4	Set screw M8 x 25	
⑧	011093	4	Spring washer M8	
⑨	022673	1	Clevis pin	
⑩	011135	2	Plain washer M16	
⑪	022674	1	Safety fastener ø16	
⑫	042207	1	Auxiliary brush push link	
⑬	011141	1	Bolt M16 x 35	
⑭	024650	As req	Air pipe, green, ø6	

Auxiliary brush, left hand, king post

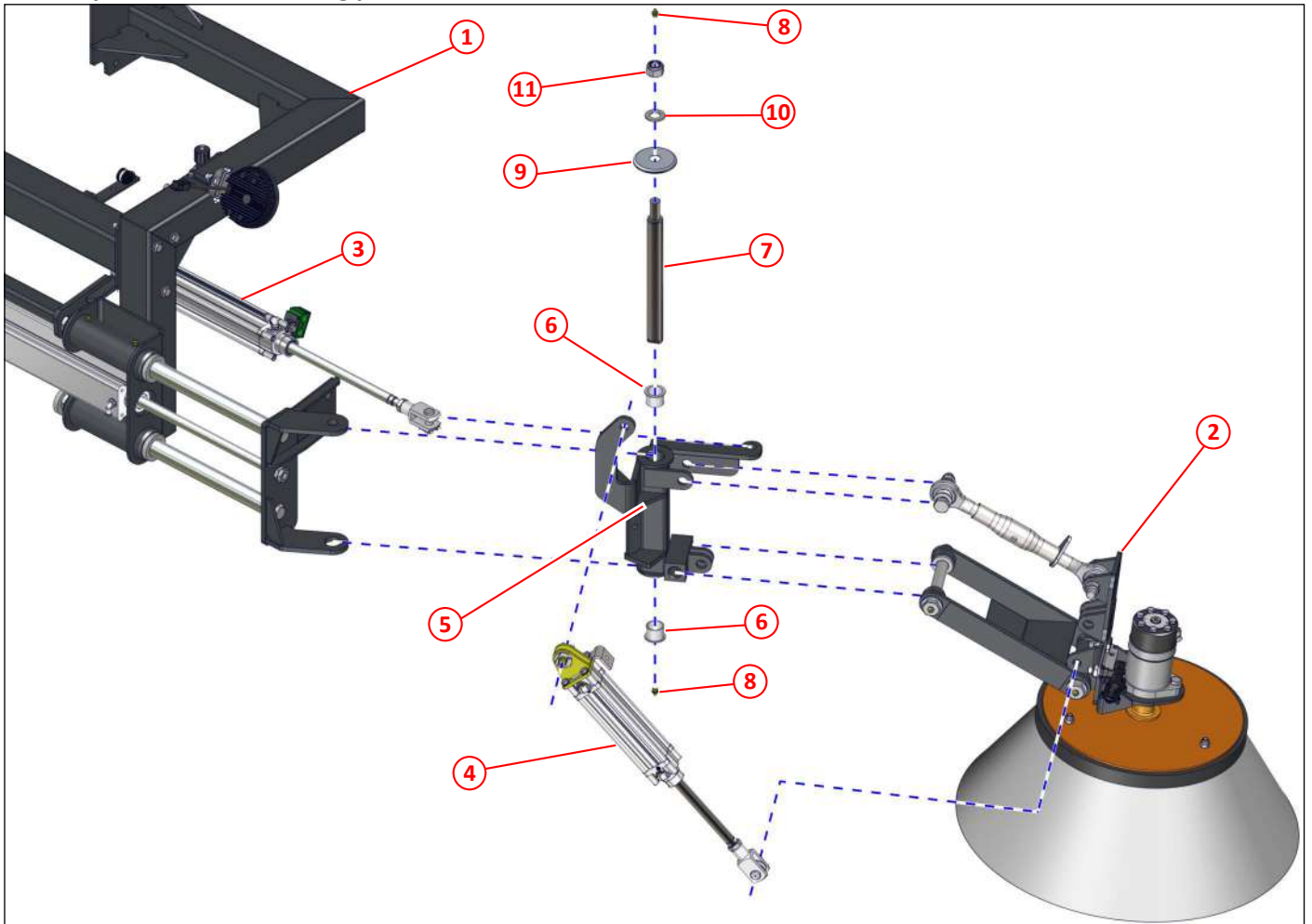

**i** Left hand shown, for a DAF LF55. For other versions please contact Scarab Parts Department.

Figure 45: Auxiliary brush, left hand, king post

Item	Part No	Qty	Description	
①	042197	1	Carrier, auxiliary brush, left hand, (DAF LF55)	
②		1	Auxiliary brush linkage and brush assembly, left hand	72
③		1	Pneumatic cylinder, left hand, auxiliary brush, swing in/out	70
④		1	Pneumatic cylinder, auxiliary brush, raise/lower	72
⑤	037915	1	King post, left hand, auxiliary brush	
⑥	013012	2	Bush, king post	
⑦	013007	1	King pin	
⑧	010903	2	Grease nipple, 1/8" BSP, straight	
⑨	013013	1	Dirt shield	
⑩	011102	1	Plain washer M20	
⑪	011082	1	Nyloc nut M20	



Auxiliary brush, left hand, raise/lower linkage

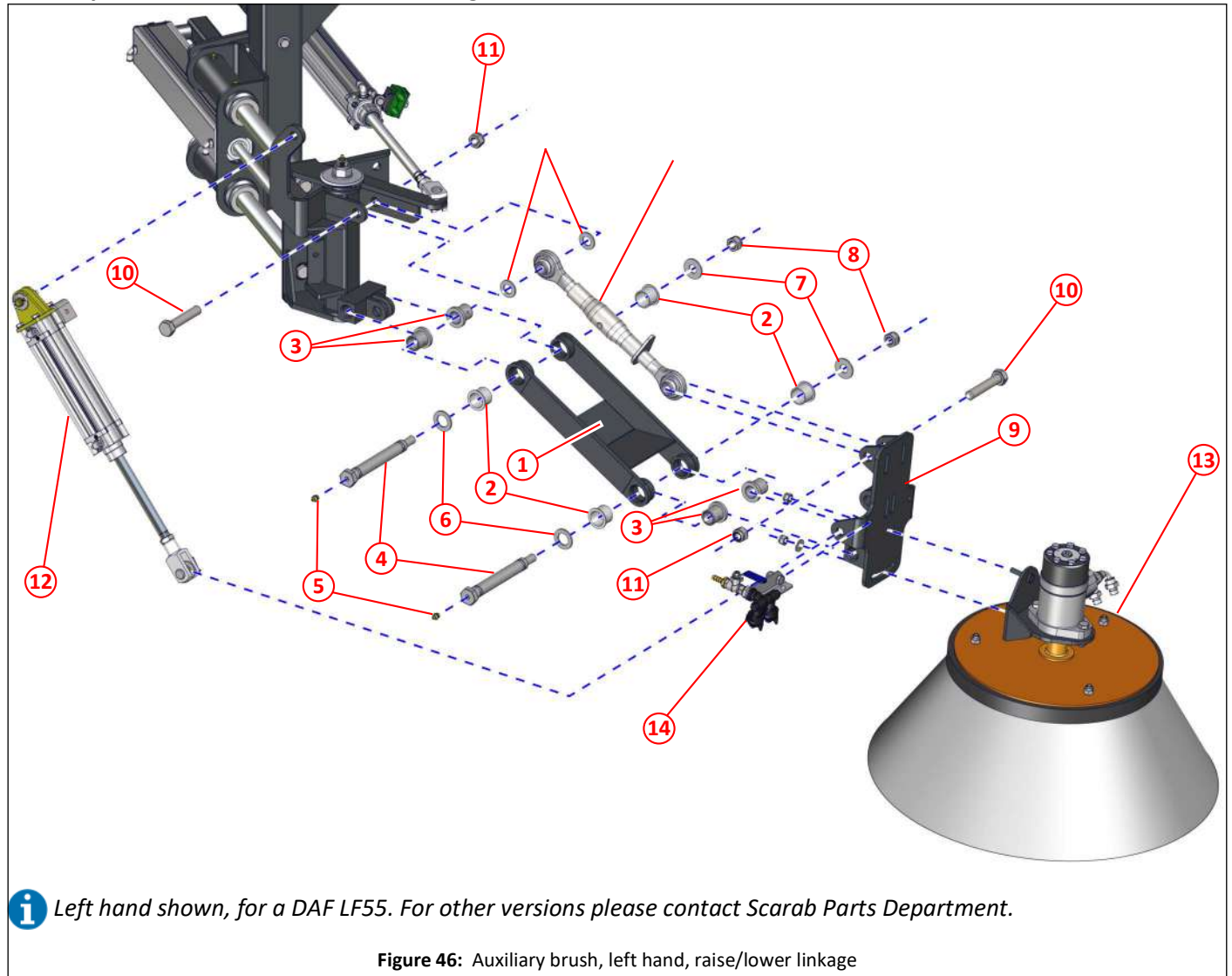

Figure 46: Auxiliary brush, left hand, raise/lower linkage

Item	Part No	Qty	Description	
①	014801	1	Brush link	
②	013012	4	Bush	
③	014799	4	Spacer sleeve	
④	014796	2	Pivot bolt	
⑤	010903	2	Grease nipple, $\frac{1}{8}$ " BSP, straight	
⑥	014798	2	Washer $\varnothing 24 \times \varnothing 40 \times 3$	
⑦	014797	2	Washer $\varnothing 17 \times \varnothing 40 \times 3$	
⑧	011060	2	Nyloc nut M16	
⑨	023121	1	Swivel plate	
⑩	011140	2	Bolt M18 x 90	
⑪	011060	2	Nyloc nut M16	
⑫		1	Pneumatic cylinder, auxiliary brush, raise/lower	313
⑬		1	Brush head assembly	73
⑭		1	Water spray nozzle, twin, left hand auxiliary brush	74



Auxiliary brush, brush and motor assembly

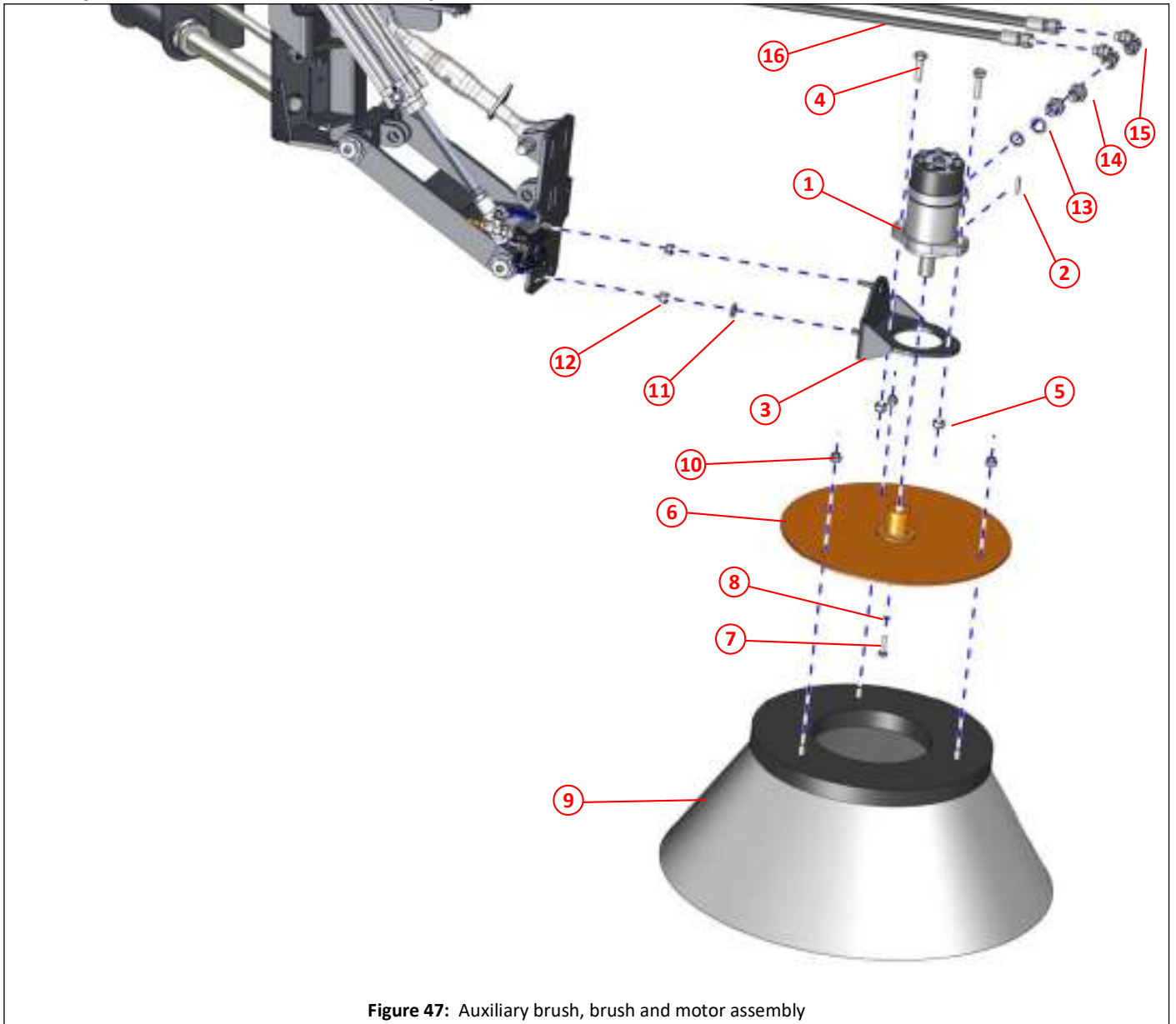

Figure 47: Auxiliary brush, brush and motor assembly

Item	Part No	Qty	Description	
①	010749	1	Motor 3597 (OMP 200)	275
②	011515	1	Key for item ①	
③	010007	1	Bracket, motor	
④	011069	2	Bolt M12 x 40	
⑤	011077	2	Nyloc nut M12	
⑥	014067	1	Brush disc	
⑦	011012	1	Set screw M8 x 30	
⑧	040197	1	Schnorr safety washer type VS8	
⑨	023473	1	Brush, steel, $\varnothing 400\text{-}\varnothing 650$	
⑩	011075	3	Nyloc nut M10	
⑪	011094	1	Plain washer M10	
⑫	011075	2	Nyloc nut M10	
⑬	011154	2	Dowty seal $\frac{1}{2}$ " BSP	
⑭	011167	2	Adapter $\frac{1}{2}$ " BSP x $\frac{3}{8}$ " BSP	
⑮	011221	2	Elbow, swept, $\frac{3}{8}$ " BSP	
⑯	001168	2	Hose, $\frac{3}{8}$ " x 1350, $\frac{3}{8}$ " BSP straight ends, to/from brush speed control valve	76

## Auxiliary brush, left hand, water jet arrangement

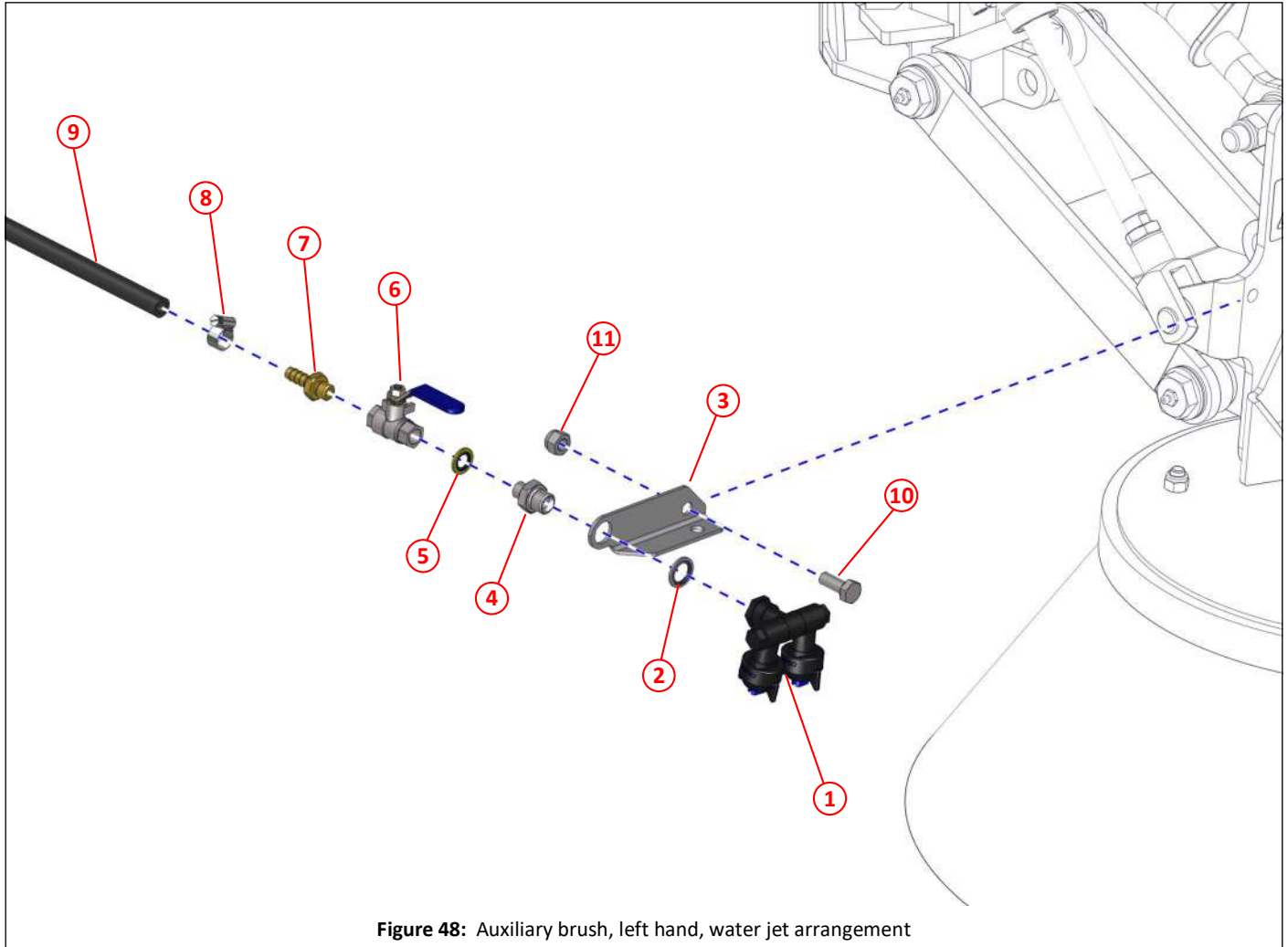

Figure 48: Auxiliary brush, left hand, water jet arrangement

Item	Part No	Qty	Description	
①	036044	1	Double swivel nozzle assembly	72,225
②	011153	1	Dowty seal $\frac{3}{8}$ " BSP	
③	036042	1	Nozzle bracket, twin nozzles, side brush, for left hand side	
④	011199	1	Adapter $\frac{3}{8}$ " x $\frac{1}{4}$ " BSP	
⑤	011152	1	Dowty seal $\frac{1}{4}$ " BSP	
⑥	011743	1	Valve, ball, $\frac{1}{4}$ " BSP	
⑦	010922	1	Adapter $\frac{1}{4}$ " BSP x $\frac{3}{8}$ " hose tail	
⑧	010516	1	Hose clamp, worm drive, No. M00 ( $\phi$ 11mm- $\phi$ 16mm)	
⑨	010950	As req	Hose $\frac{3}{8}$ "	
⑩	011031	1	Set screw M10 x25	
⑪	011075	1	Nyloc nut M10	

Auxiliary brush, bracket pipe/hose support

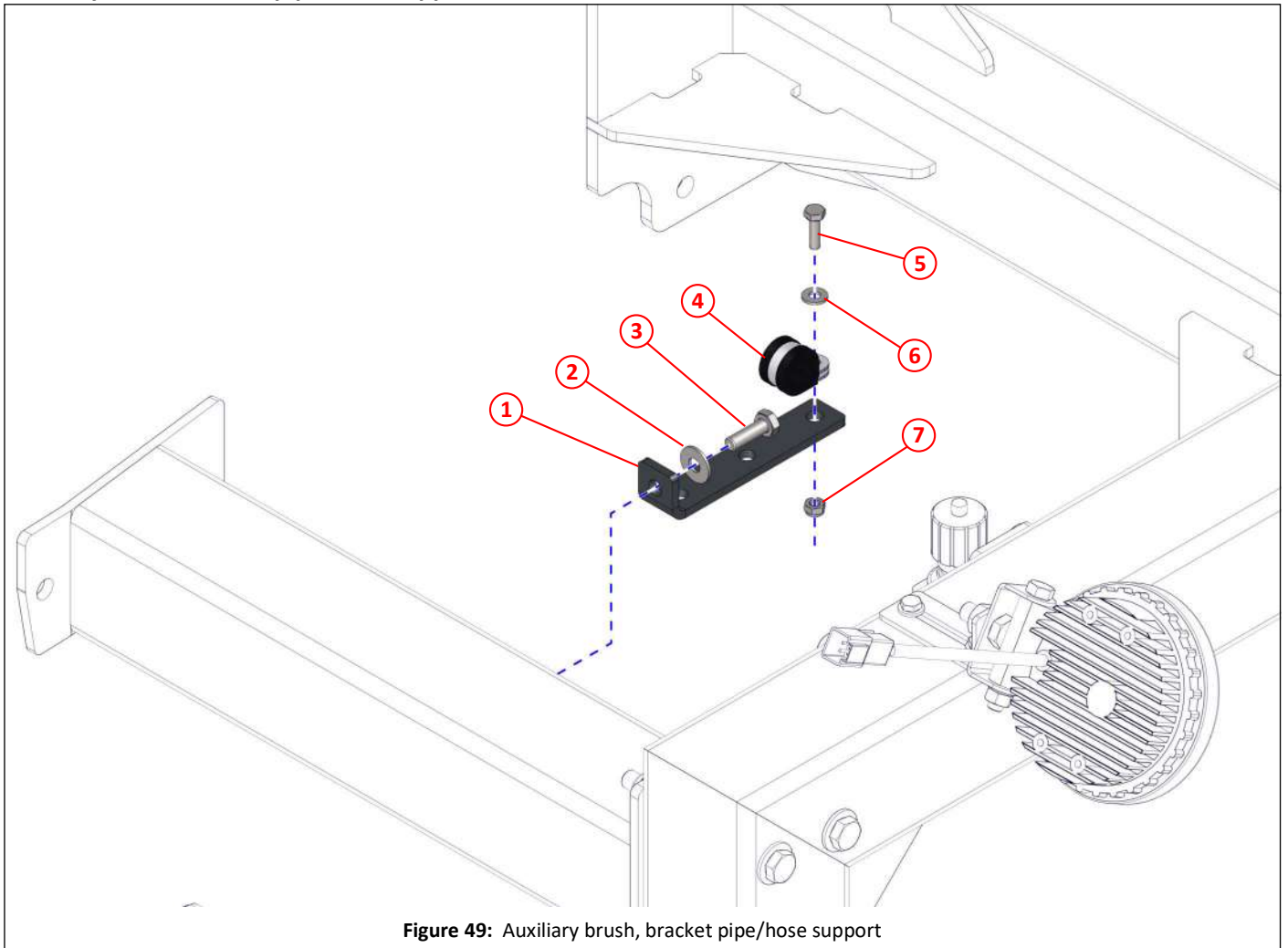

Figure 49: Auxiliary brush, bracket pipe/hose support

Item	Part No	Qty	Description
①	031921	1	Bracket, pipe/hose support
②	011092	1	Plain washer M8
③	011011	1	Set screw M8 x 25
④	005059	1	P clip $\varnothing$ 25
⑤	011067	1	Set screw M6 x 20
⑥	011090	1	Plain washer M6
⑦	011071	1	Nyloc nut M6

## Auxiliary brush, speed control valve, brush

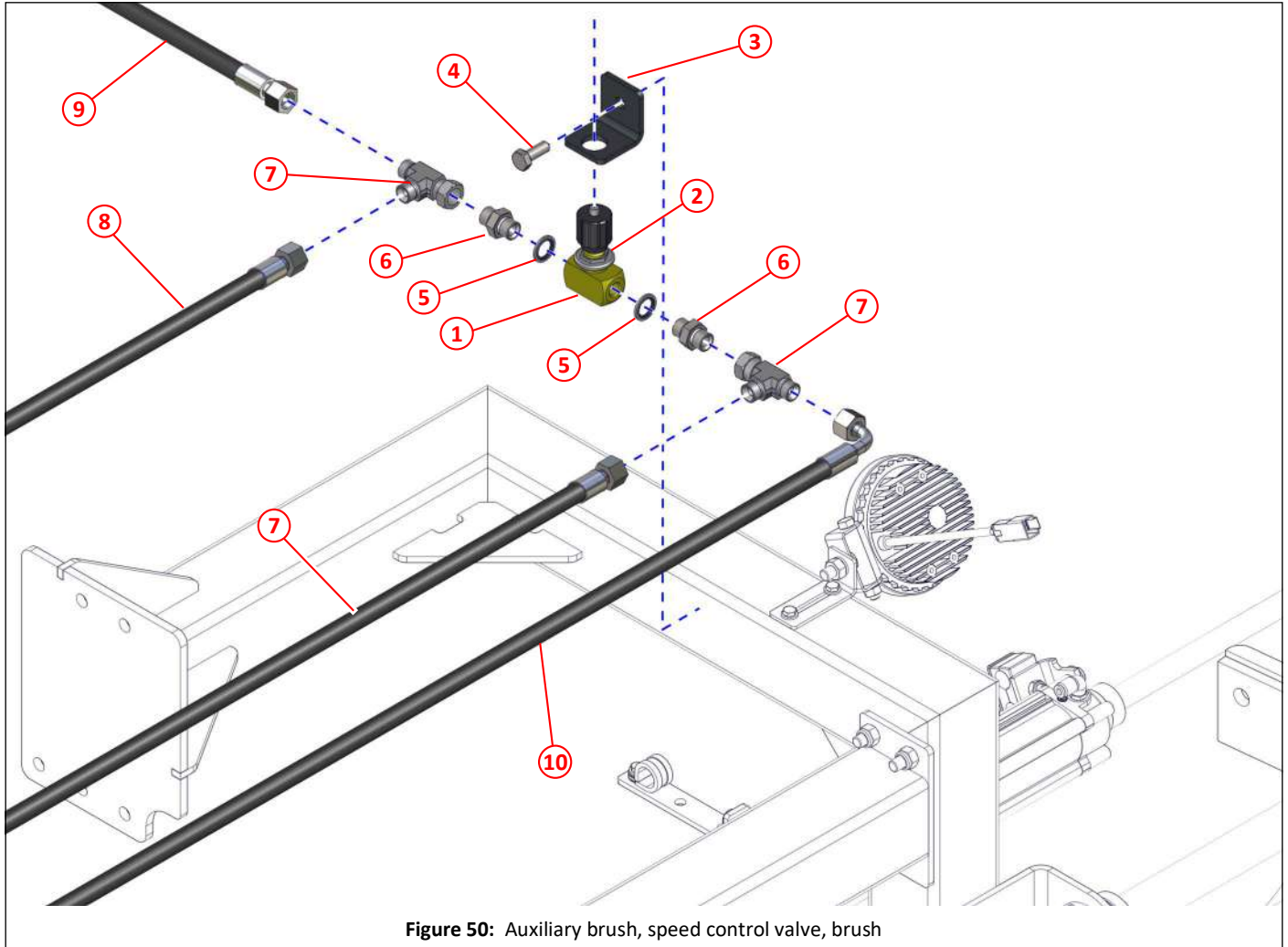

Figure 50: Auxiliary brush, speed control valve, brush

Item	Part No	Qty	Description
①	022341	1	Valve, shut off
②	039867	1	Panel mounting kit, nut and washer
③	025007	1	Bracket
④	011031	1	Set screw M10 x 25
⑤	011153	2	Dowty seal $\frac{3}{8}$ " BSP
⑥	011159	1	Adapter, M/M, $\frac{3}{8}$ " BSP
⑦	011223	2	Tee, nut on run, $\frac{3}{8}$ " BSP
⑧	001168	2	Hose, $\frac{3}{8}$ " x 1350, $\frac{3}{8}$ " BSP straight ends, to/from auxiliary brush motor
⑨	001009	1	Hose, $\frac{3}{8}$ " x 2200, $\frac{3}{8}$ " BSP, straight ends, pressure feed
⑩	001252	1	Hose, $\frac{3}{8}$ " x 2540, $\frac{3}{8}$ " BSP, straight and 90° ends, return to tank

Auxiliary brush, work lamp

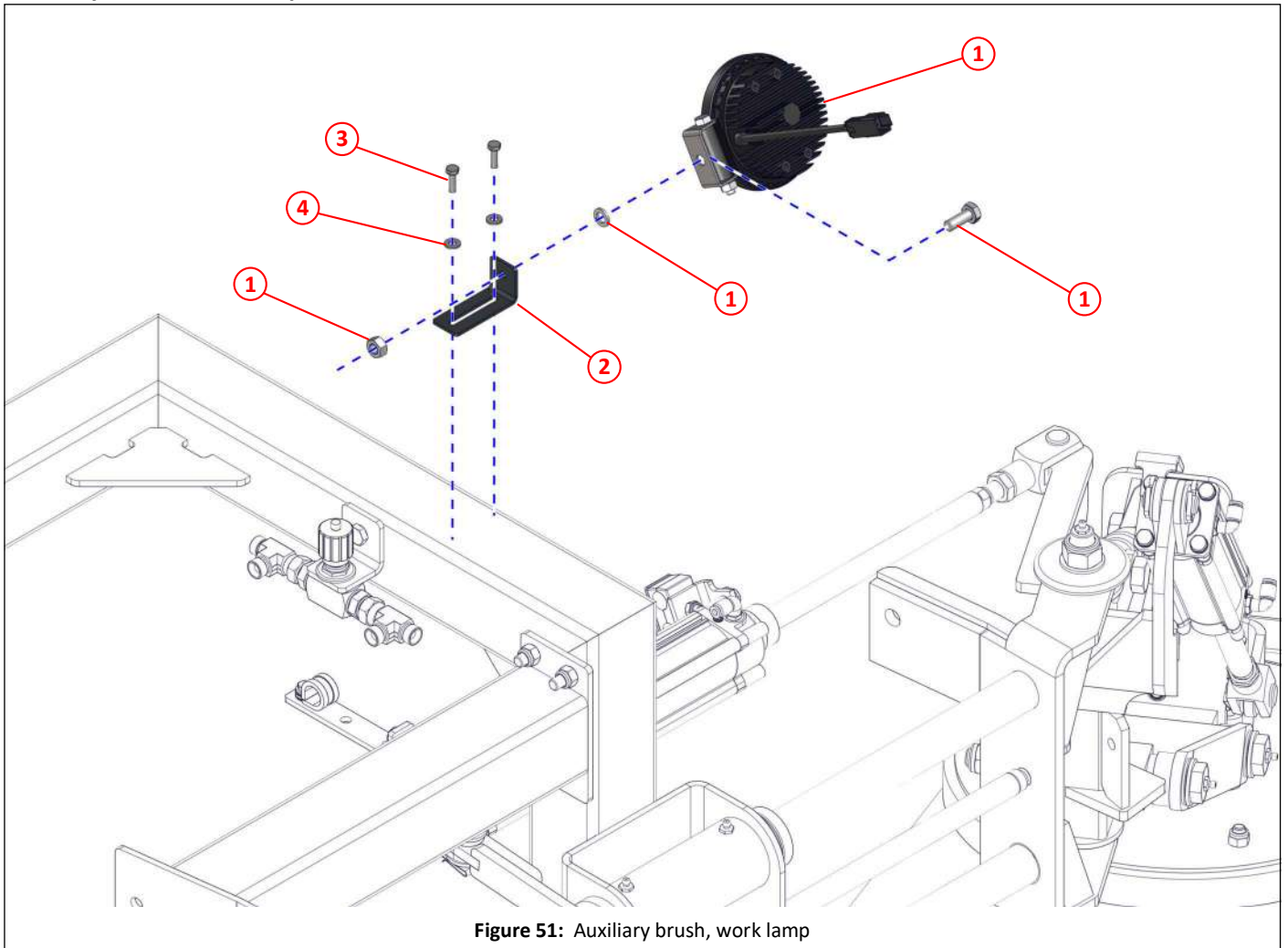

Figure 51: Auxiliary brush, work lamp

Item	Part No	Qty	Description
①	047757	1	Work lamp, LED 18W, include mounting bolt, washer and nut
②	026196	1	Bracket
③	011067	2	Set screw M6 x 20
④	011090	2	Plain washer M6





# Suction

<i>Description</i>	<i>Page</i>
Left hand suction nozzle arrangement .....	81
Left hand suction nozzle hose .....	82
Left hand suction nozzle lift mechanism .....	83
Left hand suction nozzle skirt .....	84
Left hand suction nozzle frame .....	85
Left hand suction nozzle tilt pivot .....	86
Left hand suction nozzle tilt ram .....	87
Left hand suction nozzle tilt return springs .....	88
Left hand suction nozzle, flaps and skid plate .....	89
Left hand suction spigot, deflector and blanking arrangement .....	90
Suction spigot arrangement .....	91
Suction deflector tube .....	92
Left hand suction deflector tube, deflectors and auto blanking arrangement .....	93
Left hand deflector arrangement .....	94
Deflector swing plate arrangement .....	95
Left hand auto blanking arrangement .....	96
Left hand auto blanking .....	97
Right hand suction nozzle arrangement .....	98
Right hand suction nozzle hose .....	99
Right hand suction nozzle lift mechanism .....	100
Right hand suction nozzle skirt .....	101
Right hand suction nozzle frame .....	102
Right hand suction nozzle tilt pivot .....	103
Right hand suction nozzle tilt ram .....	104
Right hand suction nozzle tilt return springs .....	105
Right hand suction nozzle, flaps and skid plate .....	106
Right hand suction spigot, deflector and blanking arrangement .....	107
Suction spigot arrangement .....	108
Suction deflector tube .....	109
Right hand suction deflector tube, deflectors and auto blanking arrangement .....	110
Right hand deflector arrangement .....	111
Deflector swing plate arrangement .....	112
Right hand auto blanking arrangement .....	113
Right hand auto blanking .....	114
Left hand rear wander hose arrangement .....	115
Left hand rear wander hose, spigot sleeve .....	116
Left hand rear wander hose, boom .....	117
Left hand rear wander hose, nozzle stowage .....	118
Right hand rear wander hose arrangement .....	119
Right hand rear wander hose, spigot sleeve .....	120
Right hand rear wander hose, boom .....	121
Right hand rear wander hose, nozzle stowage .....	122
Left hand overhead boom suction nozzle arrangement .....	123
Left hand overhead boom carrier inspection hatch and deflector .....	124
Left hand overhead boom elbow and bearing .....	125
Left hand overhead boom suction tube, pivot and cuff .....	126
Left hand overhead boom suction tube, springs .....	127
Left hand overhead boom suction hose and cradle .....	128
Left hand overhead boom locker door components .....	129
Left hand overhead boom stowage components .....	130
Right hand overhead boom suction nozzle arrangement .....	131
Right hand overhead boom carrier access cover and deflector .....	132

## Suction



Right hand overhead boom elbow and bearing .....	133
Right hand overhead boom suction tube, pivot and cuff .....	134
Right hand overhead boom suction tube, springs .....	135
Right hand overhead boom suction hose and cradle .....	136
Right hand overhead boom locker door components .....	137
Right hand overhead boom stowage components .....	138
Overhead boom extension tubes .....	139
Overhead boom water switch .....	140
PU lined suction components .....	141

Left hand suction nozzle arrangement

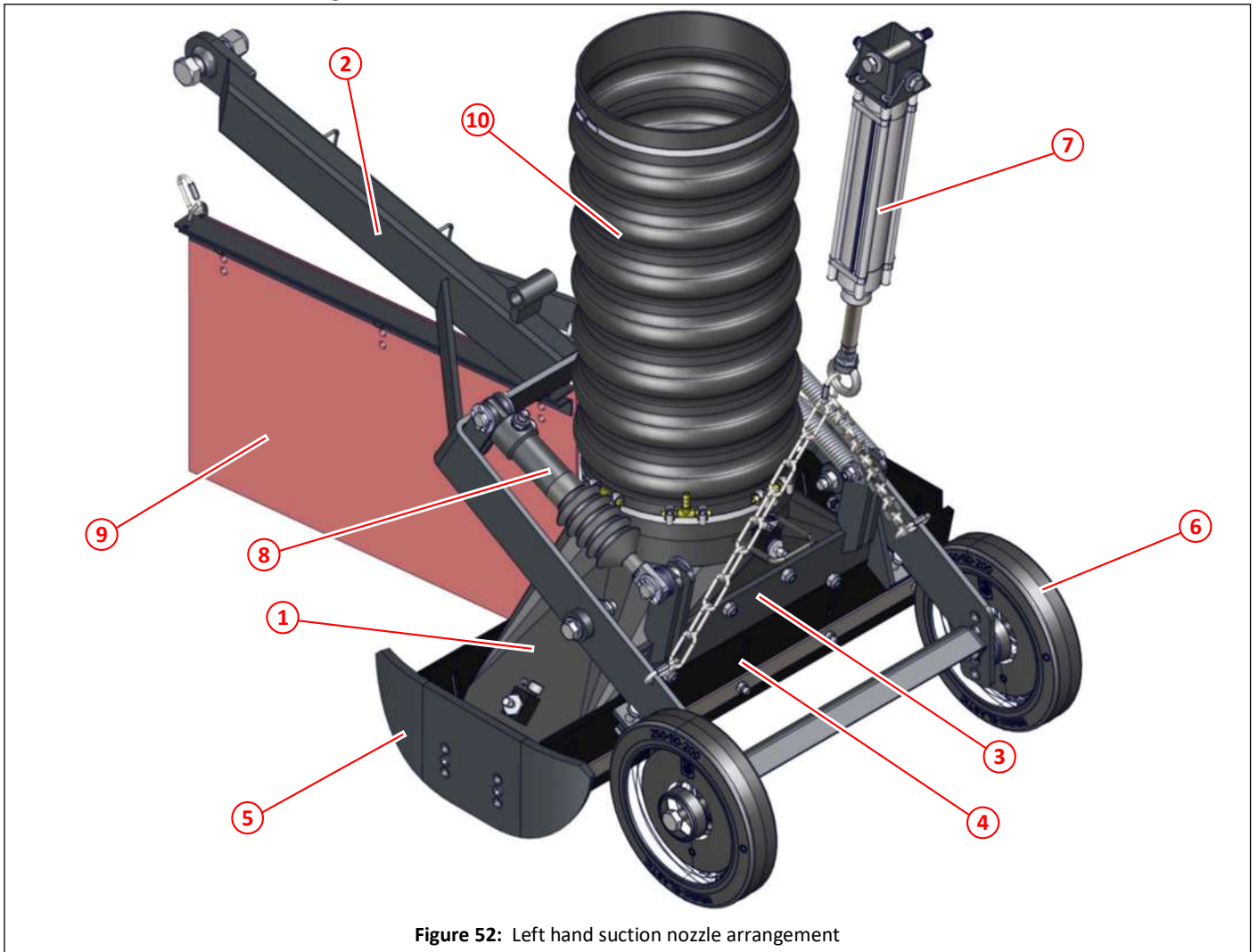

Figure 52: Left hand suction nozzle arrangement

Item	Part No	Qty	Description	
①	023604	1	Suction nozzle box	89
②	023605	1	Suction nozzle frame, left hand side	85
③	020328	1	Pivot, suction nozzle	86
④			Suction nozzle flap	89
⑤	013277	1	Skid plate, suction nozzle	89
⑥			Wheel	85
⑦			Suction nozzle lift, pneumatic cylinder	83
⑧			Suction nozzle tilt, hydraulic ram	87
⑨			Skirt	84
⑩	013028	1	Suction nozzle hose	82

Left hand suction nozzle hose

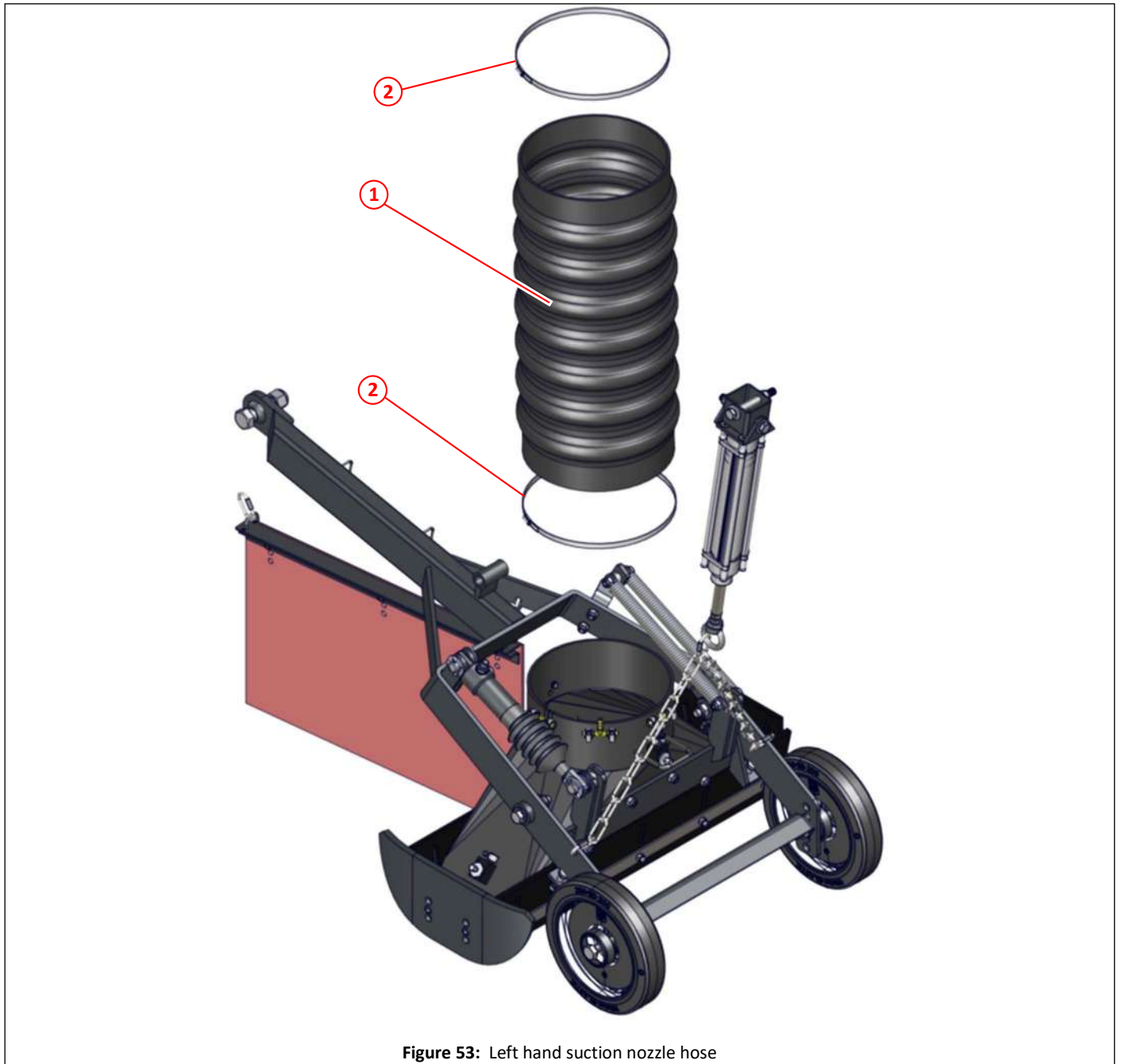

Figure 53: Left hand suction nozzle hose

Item	Part No	Qty	Description	
①	013028	1	Suction nozzle hose	81
②	012933	2	Hose clamp, worm drive, No. 10.50 (ø235mm-ø267mm)	

Left hand suction nozzle lift mechanism

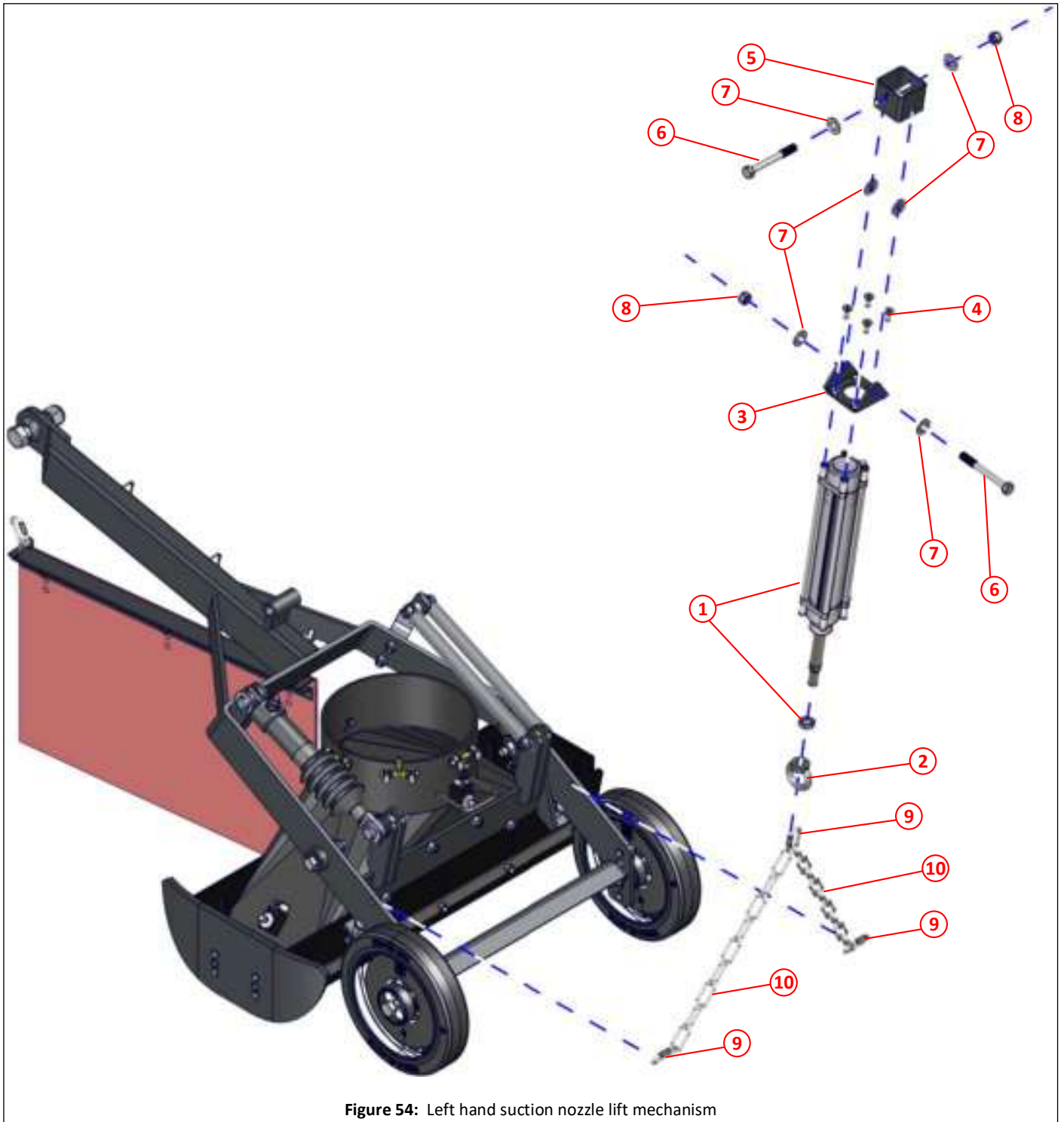

Figure 54: Left hand suction nozzle lift mechanism

Item	Part No	Qty	Description	
①	030772	1	Pneumatic cylinder 50 x 200, suction nozzle lift, includes nut	309
②	032293	1	Ring nut, M16 x 1.5	
③	030777	1	Cylinder pivot, suction nozzle lift	
④	000003	4	Socket countersunk screw M8 x 20, plated	
⑤	030776	1	Cylinder pivot block, suction nozzle lift	
⑥	011057	2	Bolt M12 x 100	
⑦	011096	6	Plain washer M12	
⑧	011077	2	Nyloc nut M12	
⑨	010606	3	Carabiner	
⑩	010525	As req	Chain, large link	

Left hand suction nozzle skirt

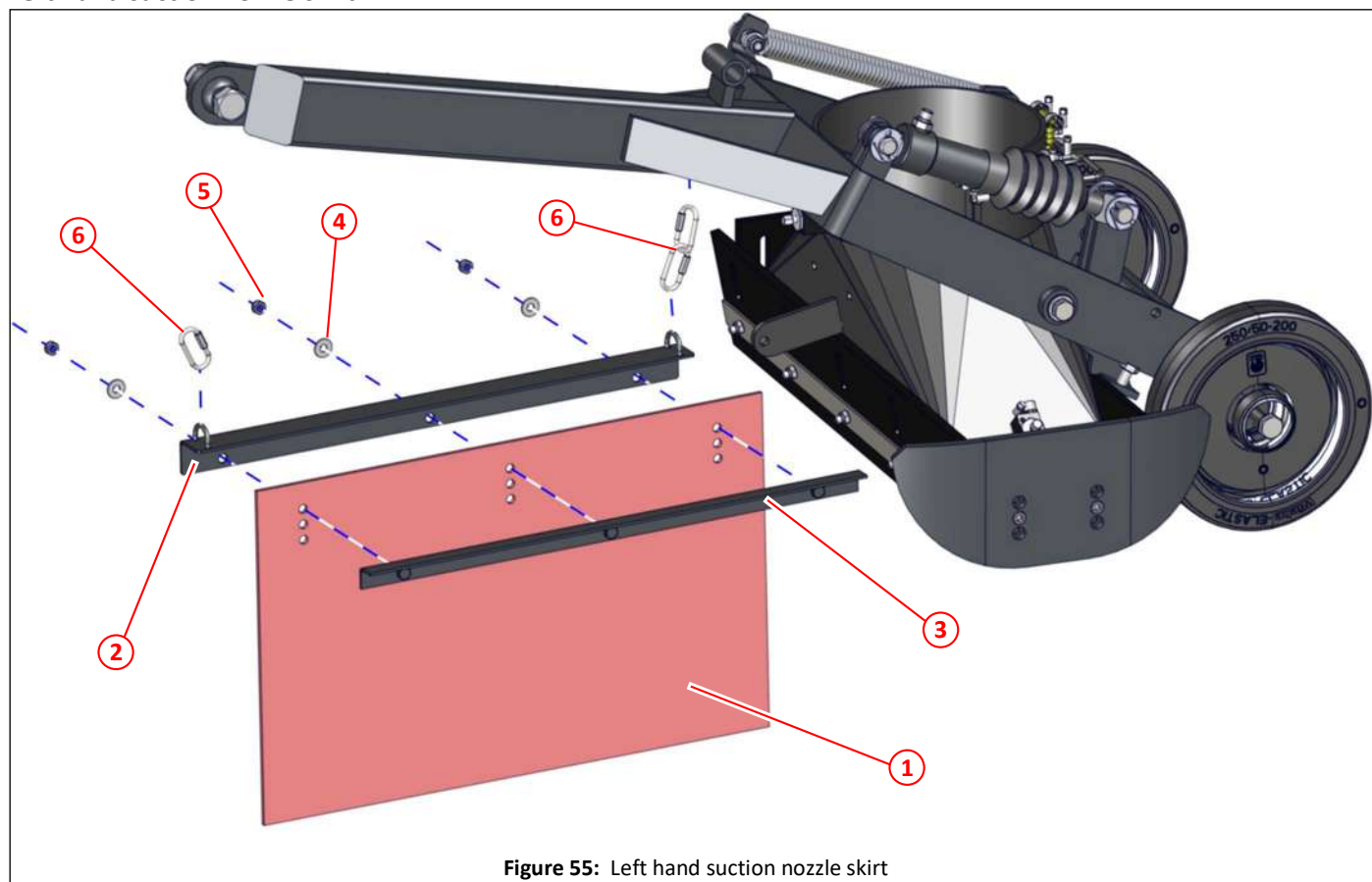

Figure 55: Left hand suction nozzle skirt

Item	Part No	Qty	Description
①	010247	1	Skirt, 3-pitch, heavy duty
②	013145	1	Skirt angle
③	010275	1	Skirt clamp
④	011092	3	Plain washer M8
⑤	011073	3	Nyloc nut M8
⑥	010606	3	Carabiner



Left hand suction nozzle frame

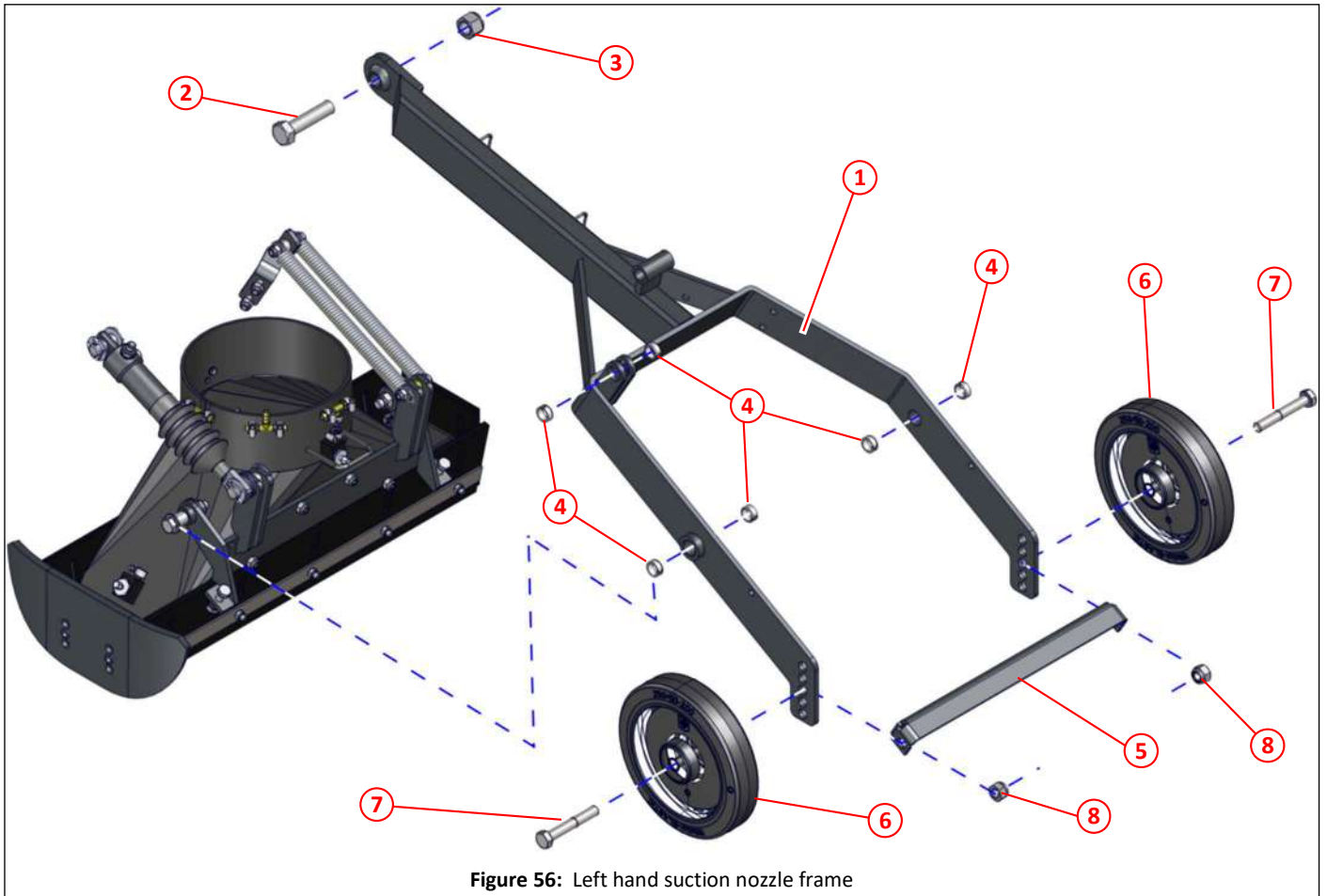

Figure 56: Left hand suction nozzle frame

Item	Part No	Qty	Description	
①	023605	1	Nozzle frame, left hand side	86,87
②	011118	1	Bolt $\frac{7}{8}$ " UNF x $3\frac{1}{2}$ "	
③	011119	1	Nyloc nut $\frac{7}{8}$ " UNF	
④	024682	6	Bush $\varnothing 20$ x $\varnothing 25$ x 10	
⑤	031833	1	Axle, nozzle	
⑥	031831	2	Wheel, nozzle	
⑦	011133	2	Bolt M16 x 100	
⑧	011060	2	Nyloc nut M16	
⑨	023604	1	Suction nozzle	89

Left hand suction nozzle tilt pivot

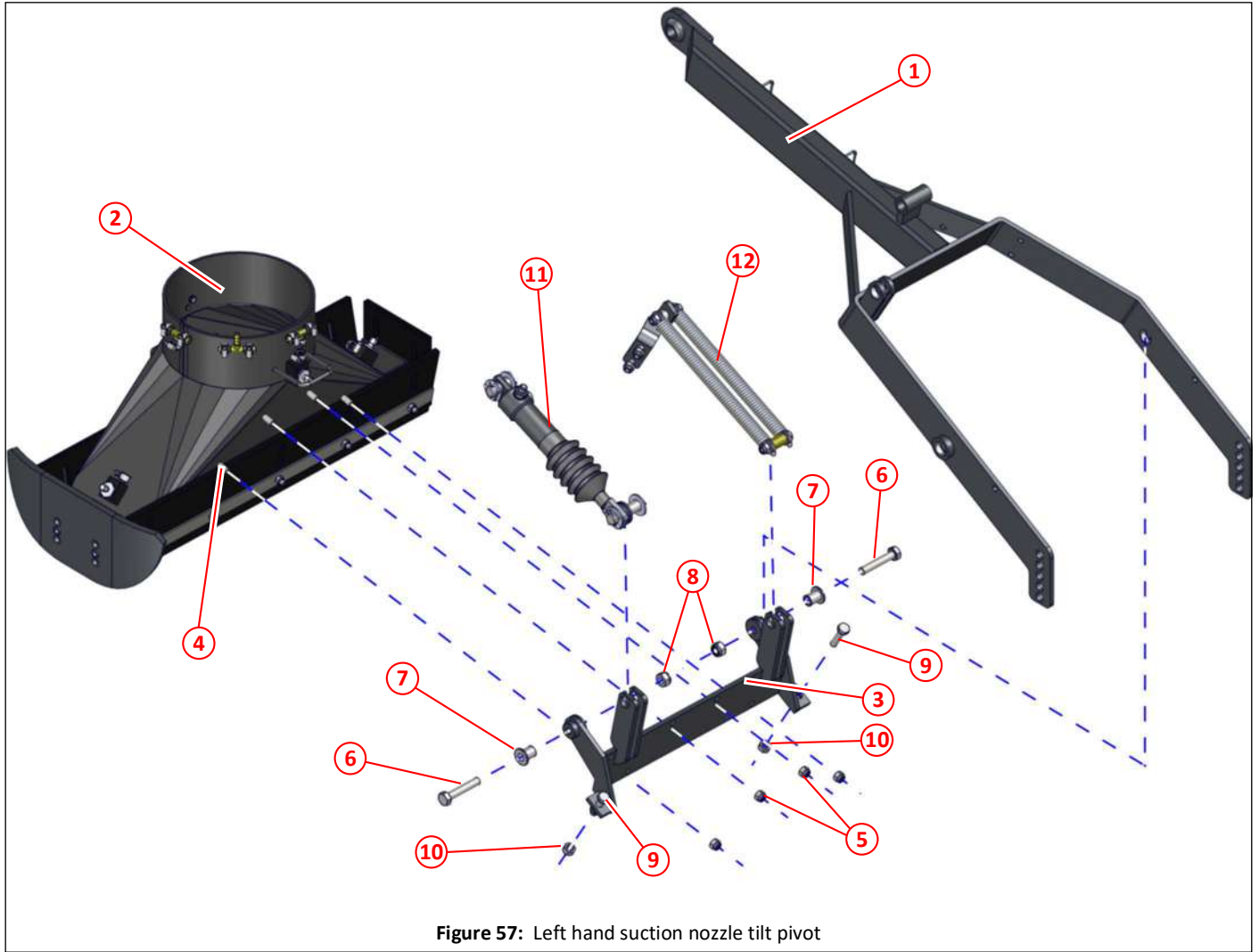

Figure 57: Left hand suction nozzle tilt pivot

Item	Part No	Qty	Description	
①	023605	1	Nozzle frame, left hand side	85,87
②	023604	1	Suction nozzle	89
③	020328	1	Pivot, suction nozzle	
④	011031	4	Set screw M10 x 25	
⑤	011075	4	Nyloc nut M10	
⑥	000351	2	Set screw M14 x 70	
⑦	021416	2	Sleeve	
⑧	011127	2	Nyloc nut M14	
⑨	011054	2	Set screw M12 x 45	
⑩	011076	2	Full nut M12	
⑪			Ram, nozzle tilt	87
⑫	010017	2	Return spring	88

Left hand suction nozzle tilt ram

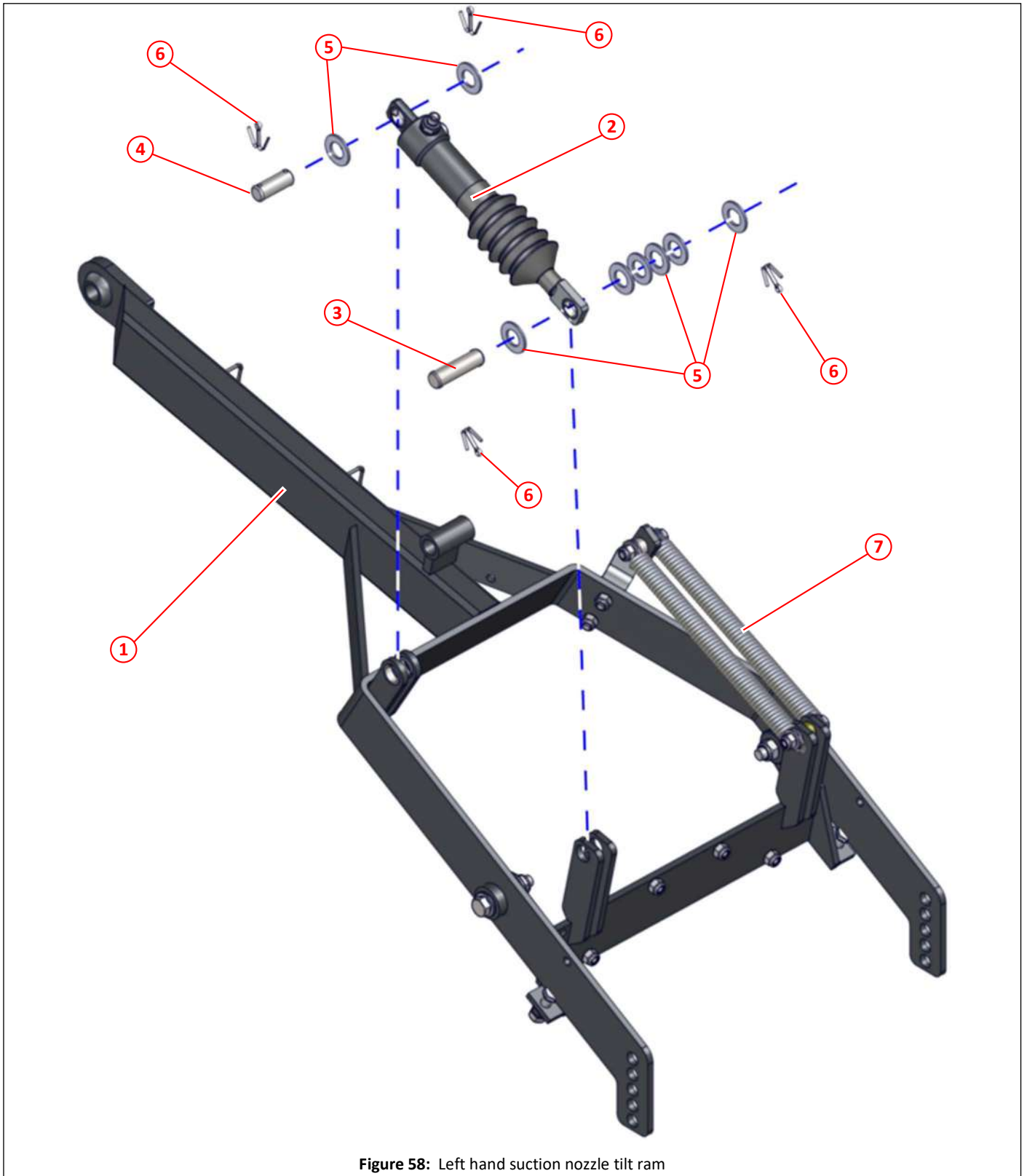

Figure 58: Left hand suction nozzle tilt ram

Item	Part No	Qty	Description	
①	023605	1	Nozzle frame, left hand side	85,86,88
②	041955	1	Ram, nozzle tilt assembly	274
③	014038	1	Pin $\varnothing 20 \times 70$	
④	010067	1	Pin $\varnothing 20 \times 50$	
⑤	011102	8	Plain washer M20	
⑥	011122	4	Split pin $\frac{3}{16}'' \times 1\frac{1}{2}''$	
⑦	010017	2	Return spring	88

Left hand suction nozzle tilt return springs

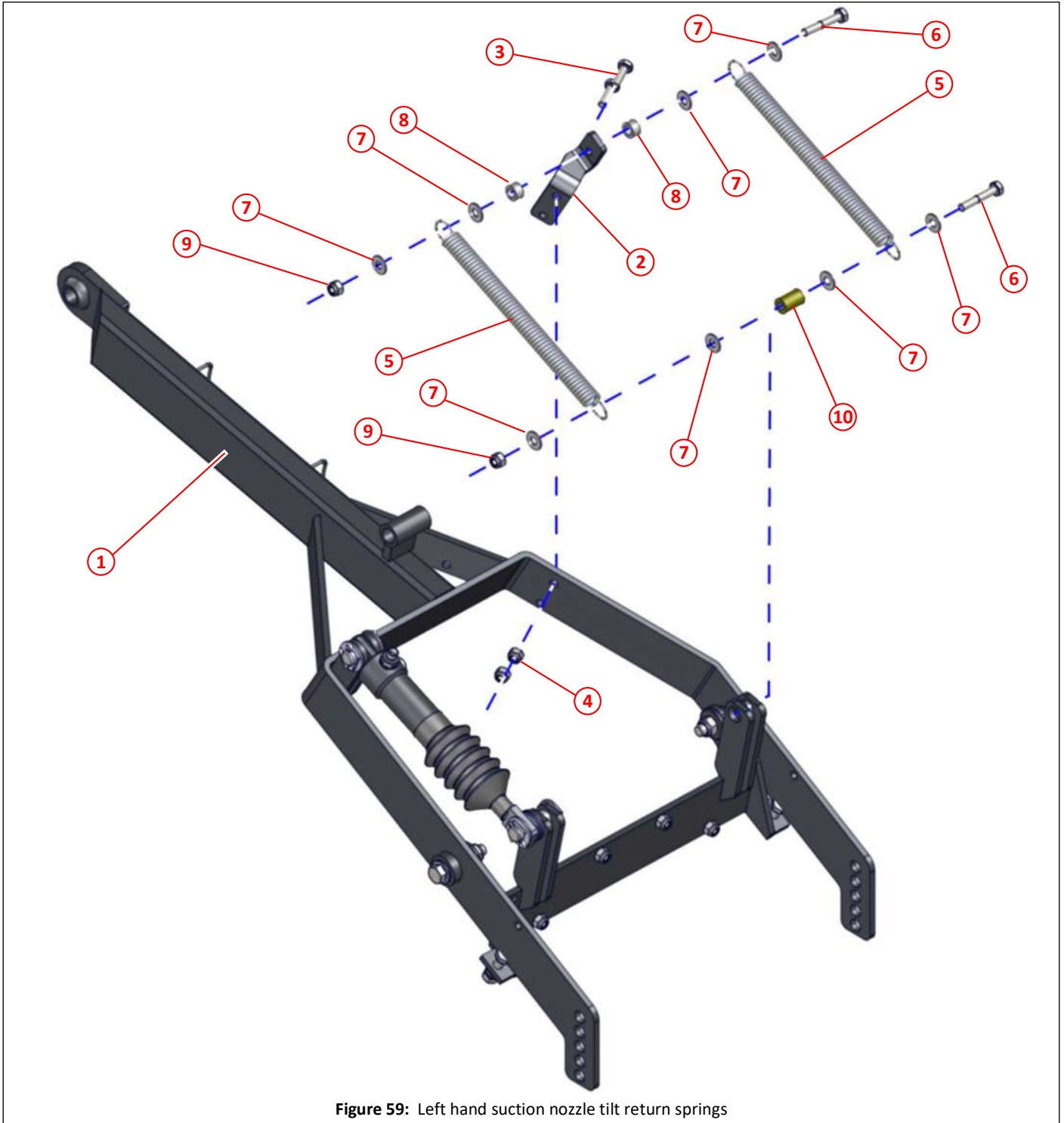

Figure 59: Left hand suction nozzle tilt return springs

Item	Part No	Qty	Description	
①	023605	1	Nozzle frame, left hand side	85,86,87
②	025099	1	Bracket, return spring	
③	011032	2	Set screw M10 x 30	
④	011075	2	Nyloc nut M10	
⑤	010017	2	Return spring	86,87
⑥	000040	2	Bolt M10 x 55	
⑦	011094	8	Plain washer M10	
⑧	011724	2	Spacer $\phi 12.5 \times \phi 20 \times 11$	
⑨	011075	2	Nyloc nut M10	
⑩	013363	1	Sleeve, spacer	

Left hand suction nozzle, flaps and skid plate

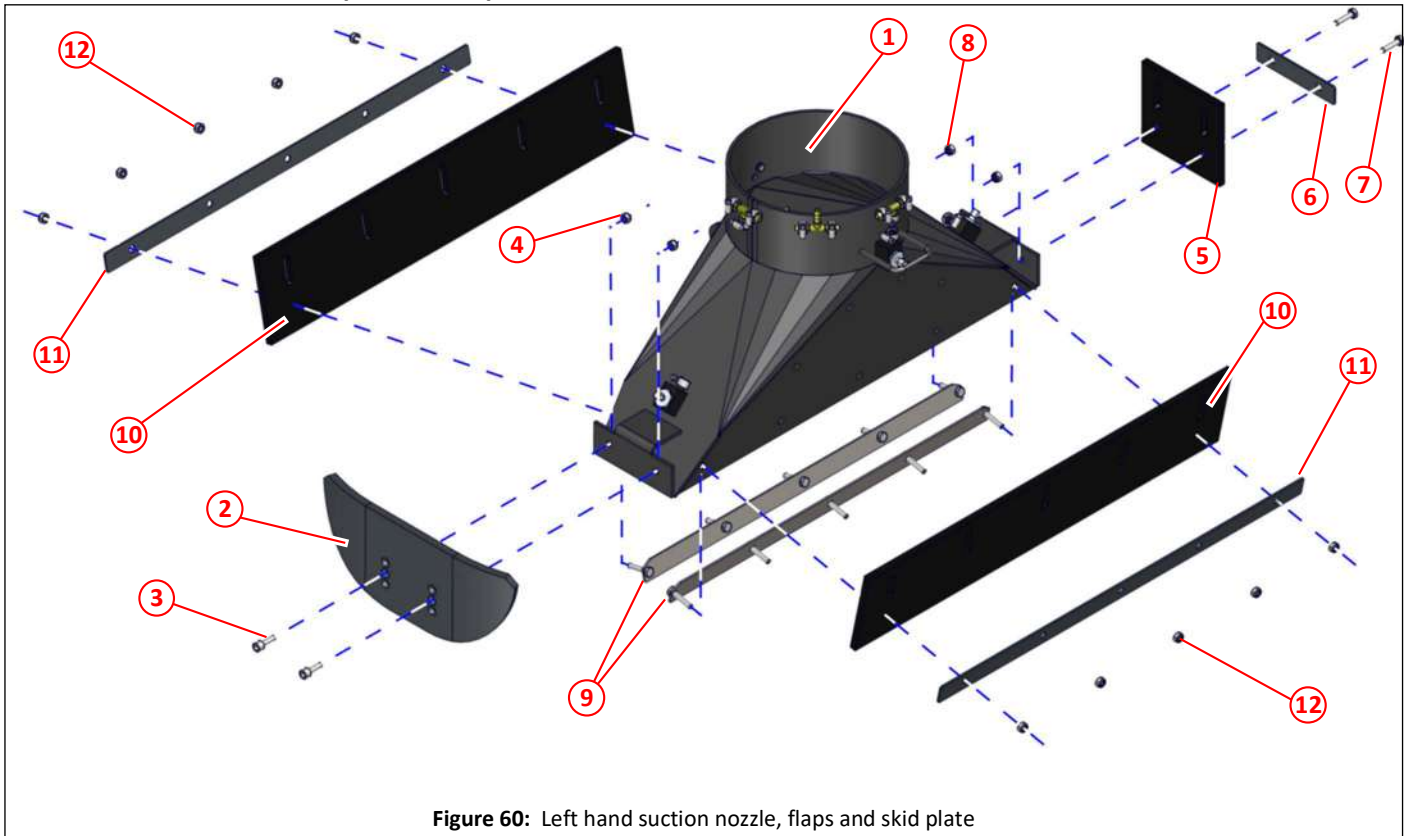

Figure 60: Left hand suction nozzle, flaps and skid plate

Item	Part No	Qty	Description	
①	023604	1	Suction nozzle	81
①	050718	1	Suction nozzle, PU lined	141
②	013277	1	Skid plate, suction nozzle	81
③	011021	2	Socket cap screw M8 x 25	
④	011073	2	Nyloc nut M8	
⑤	013283	1	Flap, side, suction nozzle	
⑥	013024	1	Clamp, flap, side, suction nozzle	
⑦	011012	2	Set screw M8 x 30	
⑧	011073	2	Nyloc nut M8	
⑨	013362	2	Bolt retainer, flap, suction nozzle	
⑩	013023	2	Flap, front/rear, suction nozzle	
⑪	013025	2	Clamp, flap, front/rear, suction nozzle	
⑫	011073	10	Nyloc nut M8	
NI	024550		Flap kit, items ⑤ and 2 x ⑩	



Left hand suction spigot, deflector and blanking arrangement

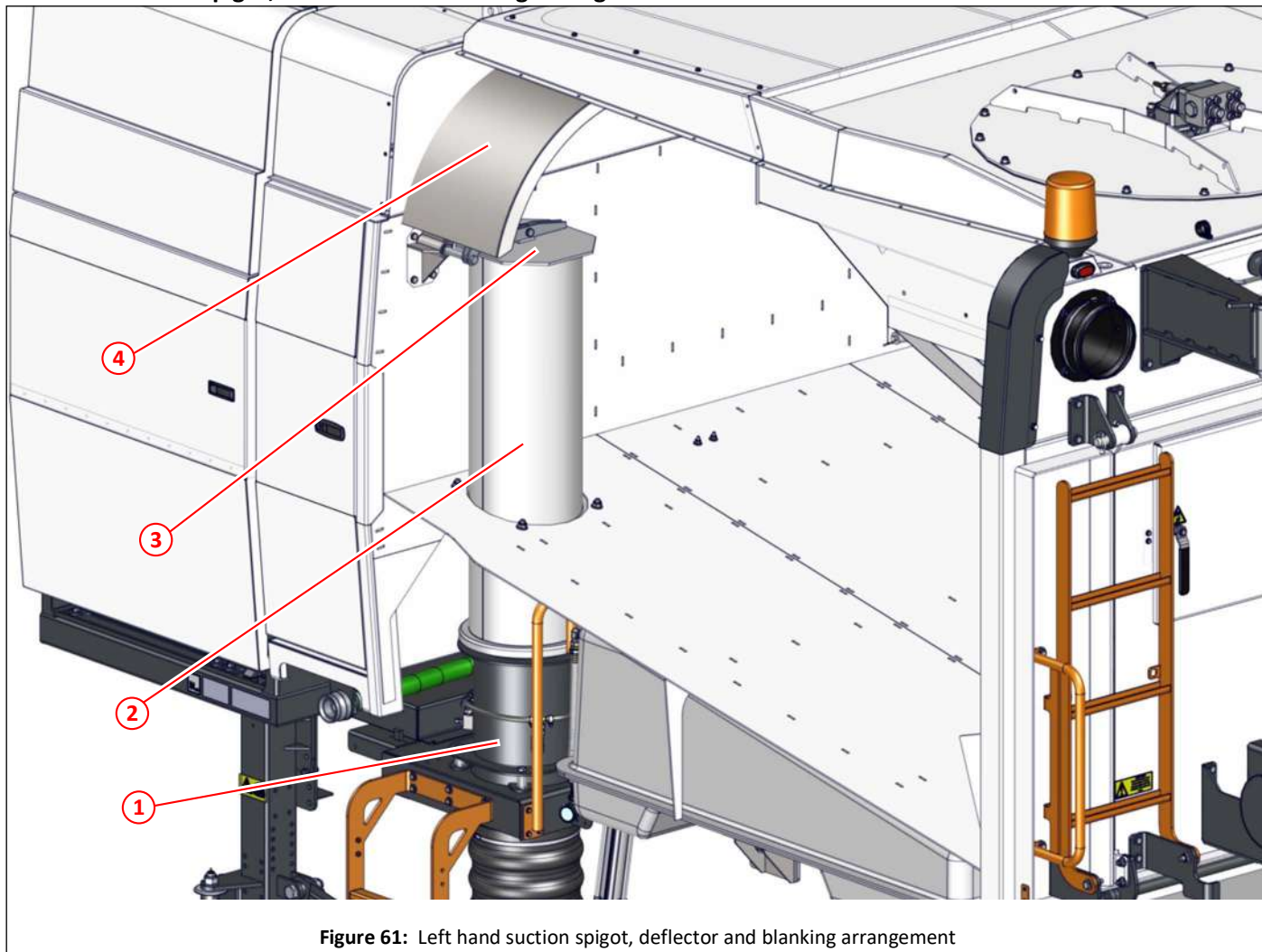

Figure 61: Left hand suction spigot, deflector and blanking arrangement

Item	Part No	Qty	Description	
①	043043	1	Suction spigot	91,92
②	044603	1	Tube, deflector	91,92
③			Auto blanking, left hand	96
④	022644	1	Deflector	93,94,96



Suction spigot arrangement

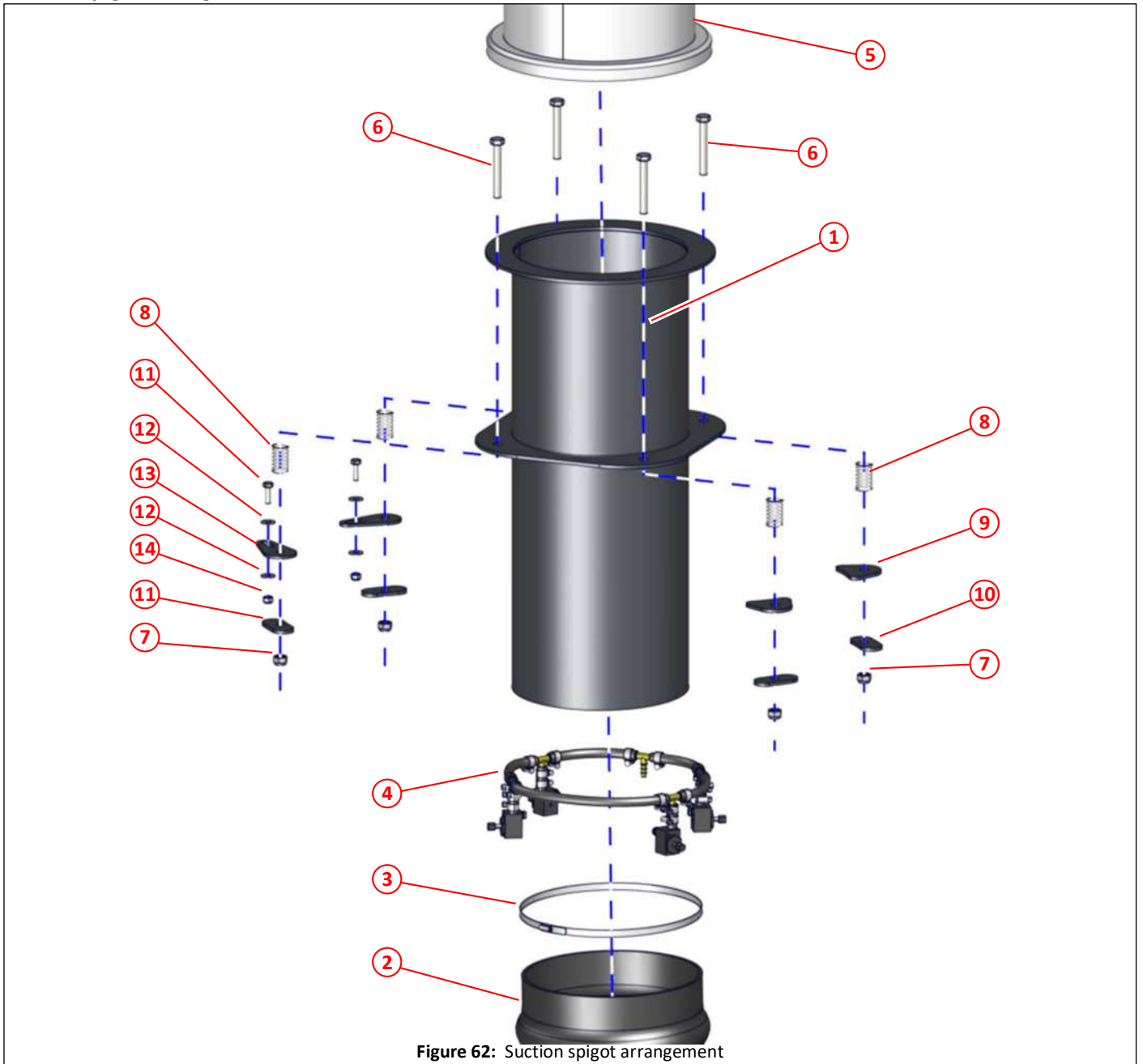

Figure 62: Suction spigot arrangement

Item	Part No	Qty	Description	
①	043043	1	Suction spigot	90,92
②	013028	1	Suction nozzle hose	81,82
③	012933	2	Hose clamp, worm drive, No. 10.50 (ø235mm-ø267mm)	
④			Additional water jets	228
⑤	044603	1	Tube, deflector	92,93
⑥	000110	4	Bolt M12 x 80	
⑦	011077	4	Nyloc nut M12	
⑧	042694	4	Spring	
⑨	043044	2	Spring seat, suction spigot	
⑩	039989	2	Washer, special	
⑪	011011	2	Set screw M8 x 25	
⑫	011092	4	Plain washer M8	
⑬	043392	2	Locking washer, suction spigot	
⑭	011073	2	Nyloc nut M8	

Suction deflector tube

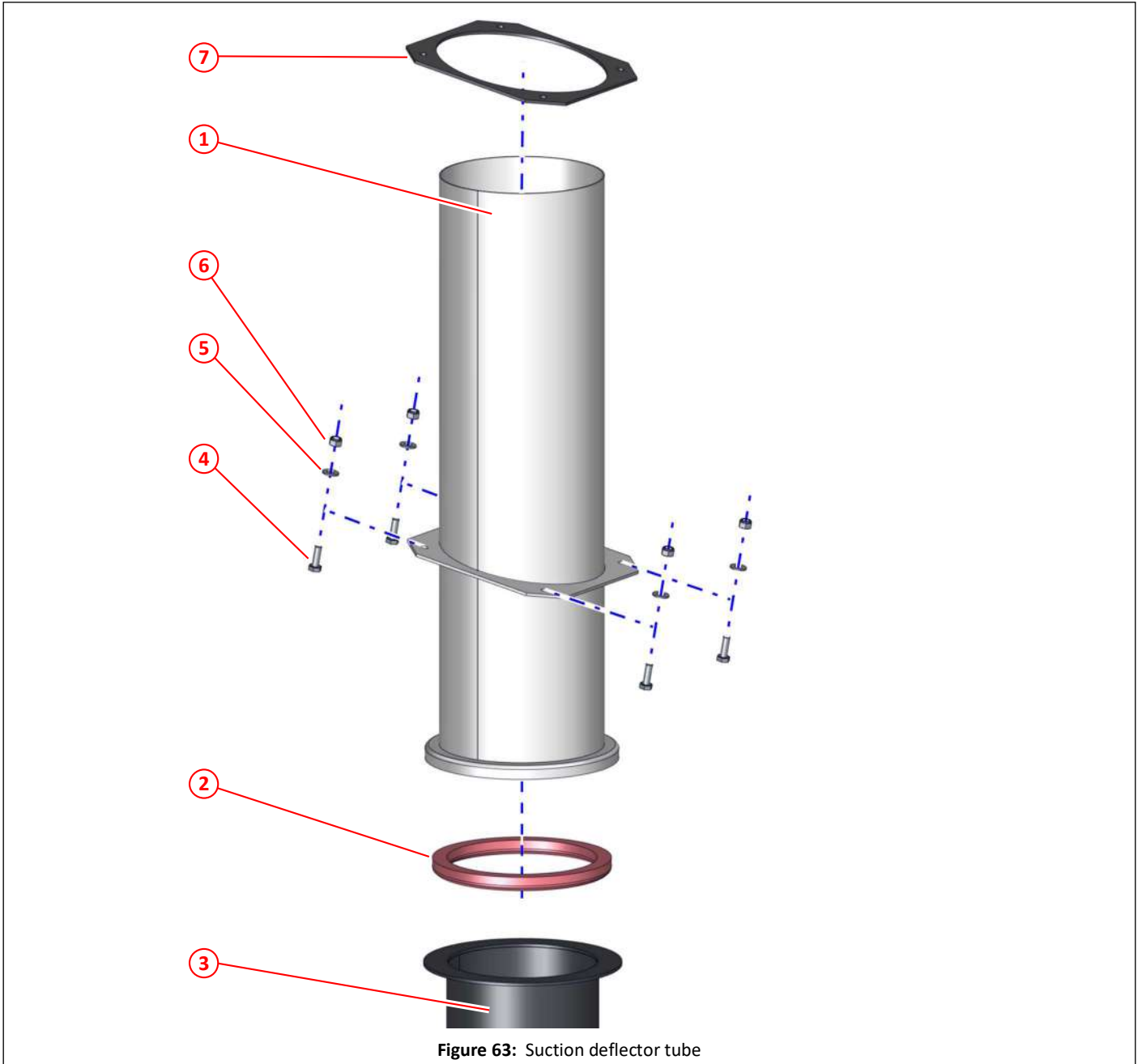
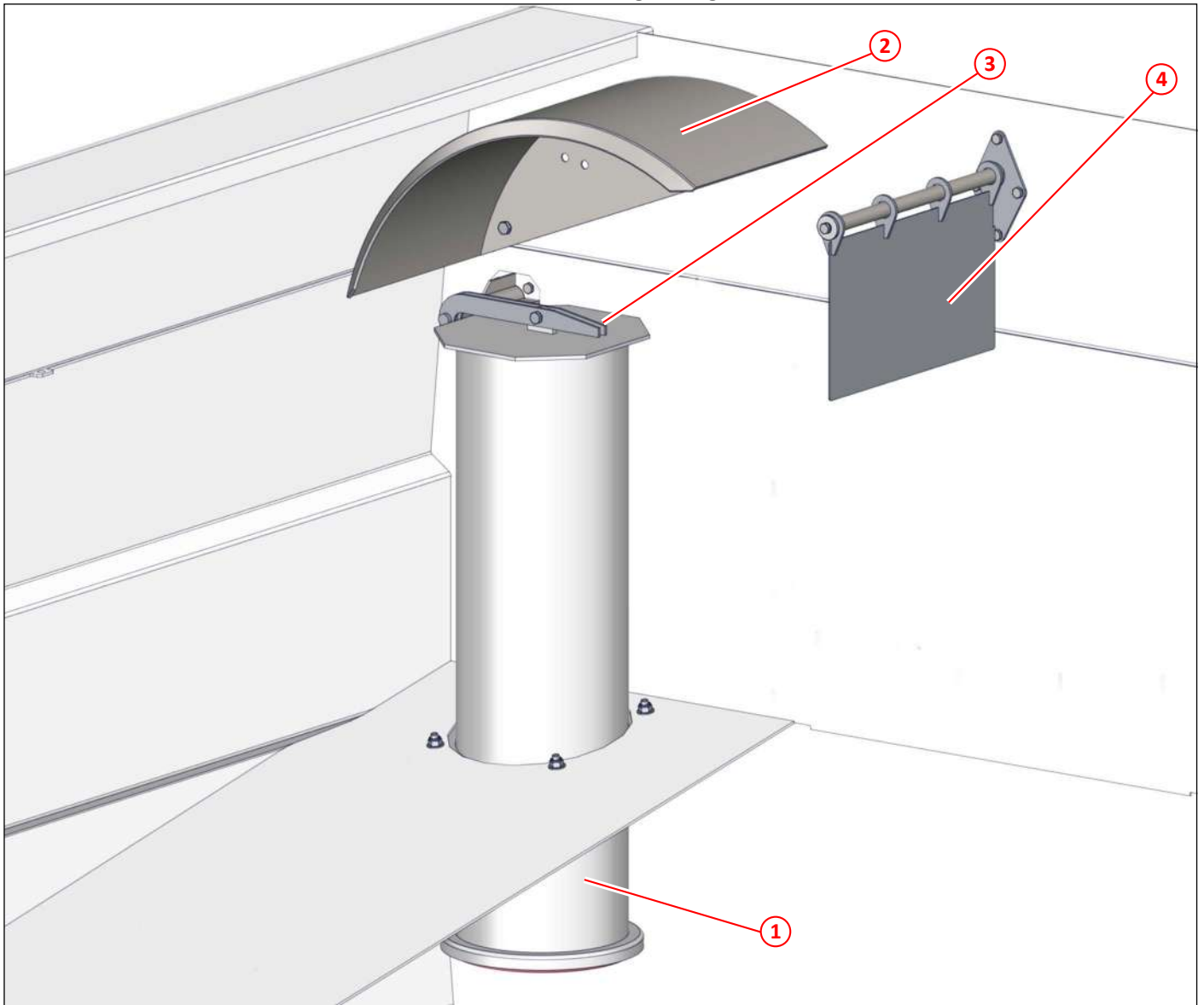

Figure 63: Suction deflector tube

Item	Part No	Qty	Description	
①	044603	1	Tube, deflector	90,91,92
①	051106	1	Tube, deflector, PU lined	141
②	039140	1	Seal, deflector tube	
③	043043	1	Suction spigot	90,91
③	051137	1	Suction spigot, PU lined	141
④	000285	4	Set screw M12 x 35, stainless steel	
⑤	000277	4	Plain washer M12, stainless steel	
⑥	000275	4	Nyloc nut M12, stainless steel	
⑦	044674	1	Gasket seal, deflector/hopper	

Left hand suction deflector tube, deflectors and auto blanking arrangement



**i** Shown from inside cutaway hopper to help with clarity.

Figure 64: Left hand suction deflector tube, deflectors and auto blanking arrangement

Item	Part No	Qty	Description	
①	044603	1	Tube, deflector	90,91,92
①	051106	1	Tube, deflector, PU lined	141
②	022644	1	Deflector	90,94,96
③			Auto blanking, left hand	94,96,97
④			Deflector swing plate	94,95,141

Left hand deflector arrangement

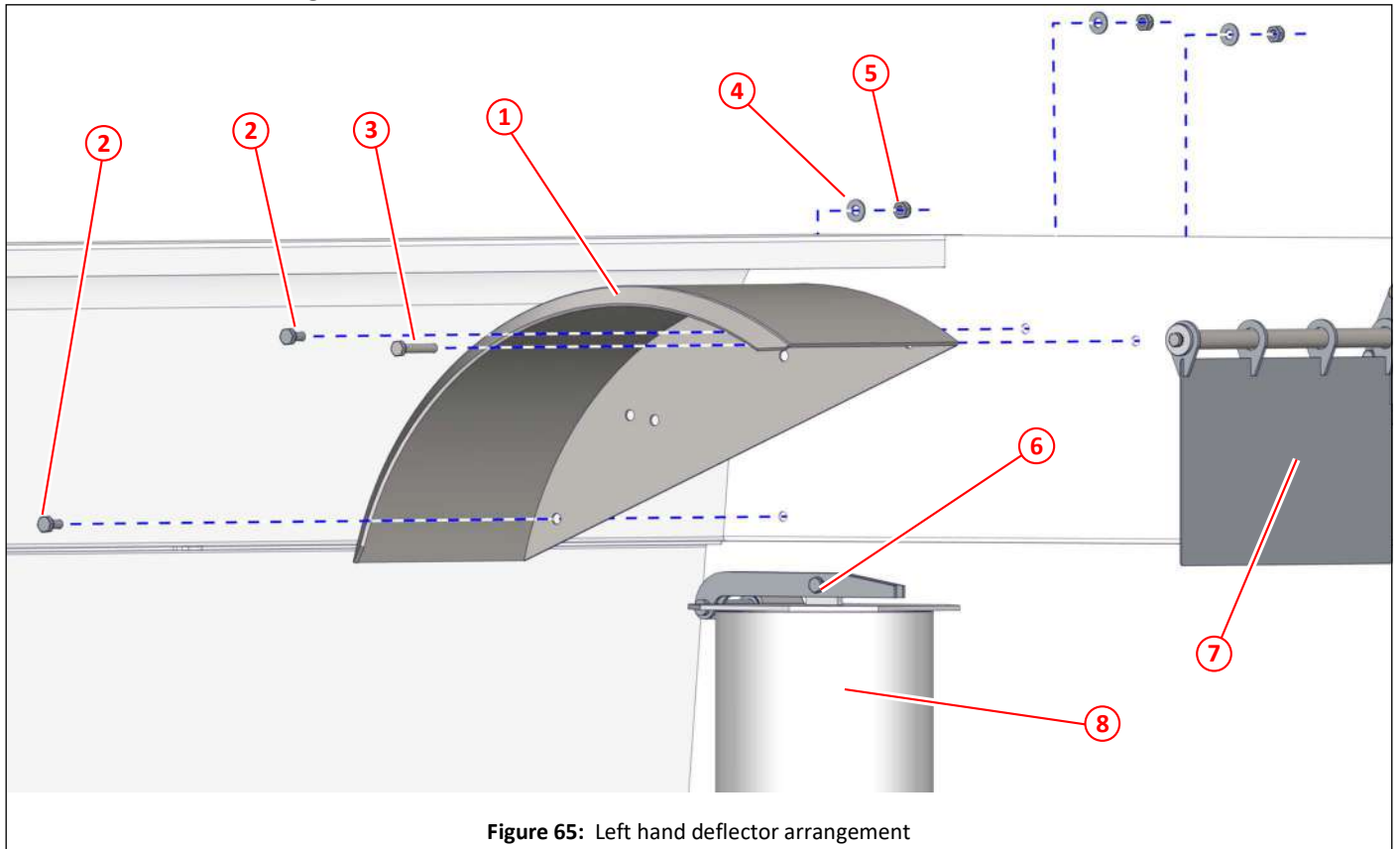

Figure 65: Left hand deflector arrangement

Item	Part No	Qty	Description	
①	022644	1	Deflector	94,96
①		1	Deflector, PU lined	141
②	000273	2	Set screw M12 x 25, stainless steel	
③	011056	1	Bolt M12 x 70	
④	000277	4	Plain washer M12, stainless steel	
⑤	000275	4	Nyloc nut M12, stainless steel	
⑥			Auto blanking, left hand	96,97
⑦			Deflector swing plate	95,141
⑧	044603	1	Tube, deflector	90,91,92,93,141

Deflector swing plate arrangement

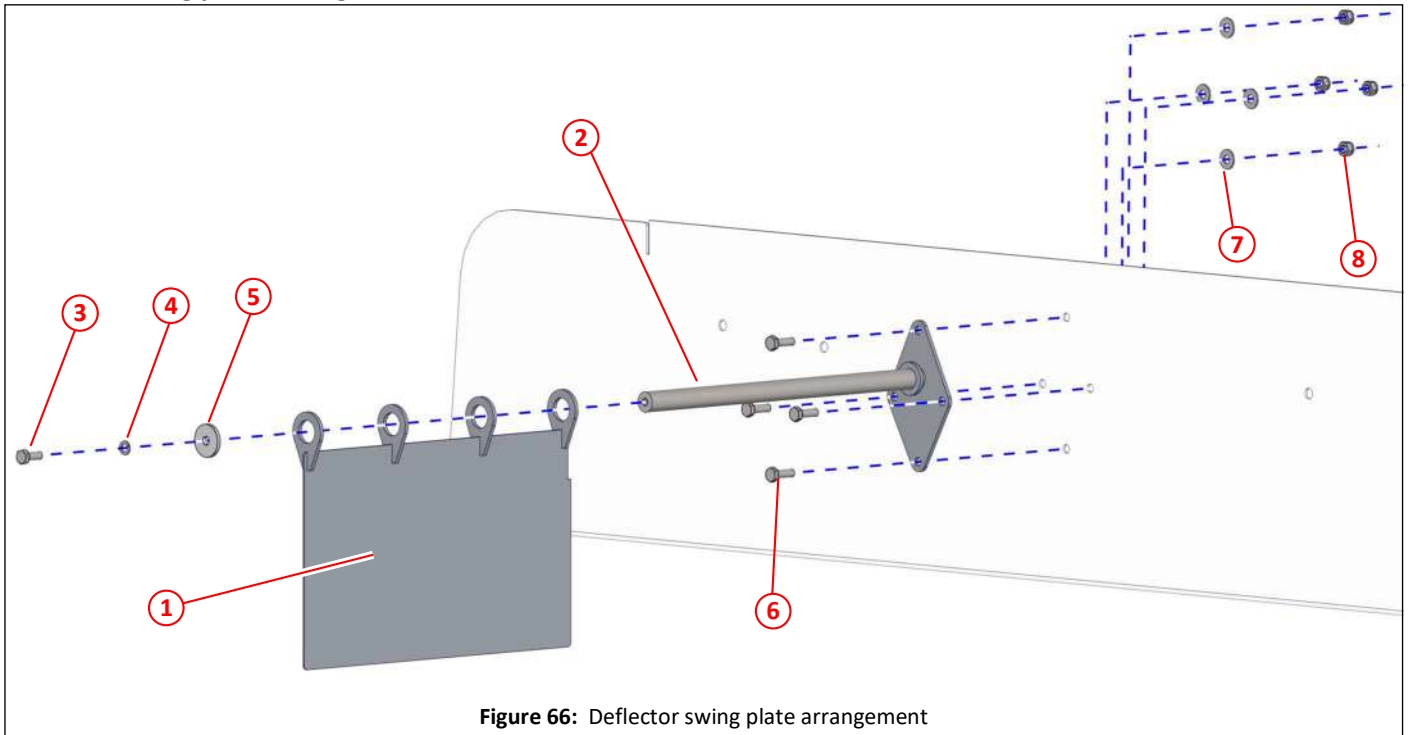

Figure 66: Deflector swing plate arrangement

Item	Part No	Qty	Description	
①	044618	1	Deflector swing plate	93,94
①	044606	1	Deflector swing plate, PU lined	141
②	044605	1	Mounting bar, deflector flap	
③	011031	1	Set screw M10 x 25	
④	011095	1	Spring washer M10	
⑤	030537	1	Washer $\phi 10.5 \times \phi 40 \times 5$	
⑥	011032	4	Set screw M10 x 30	
⑦	011094	4	Plain washer M10	
⑧	011075	4	Nyloc nut M10	

Left hand auto blanking arrangement

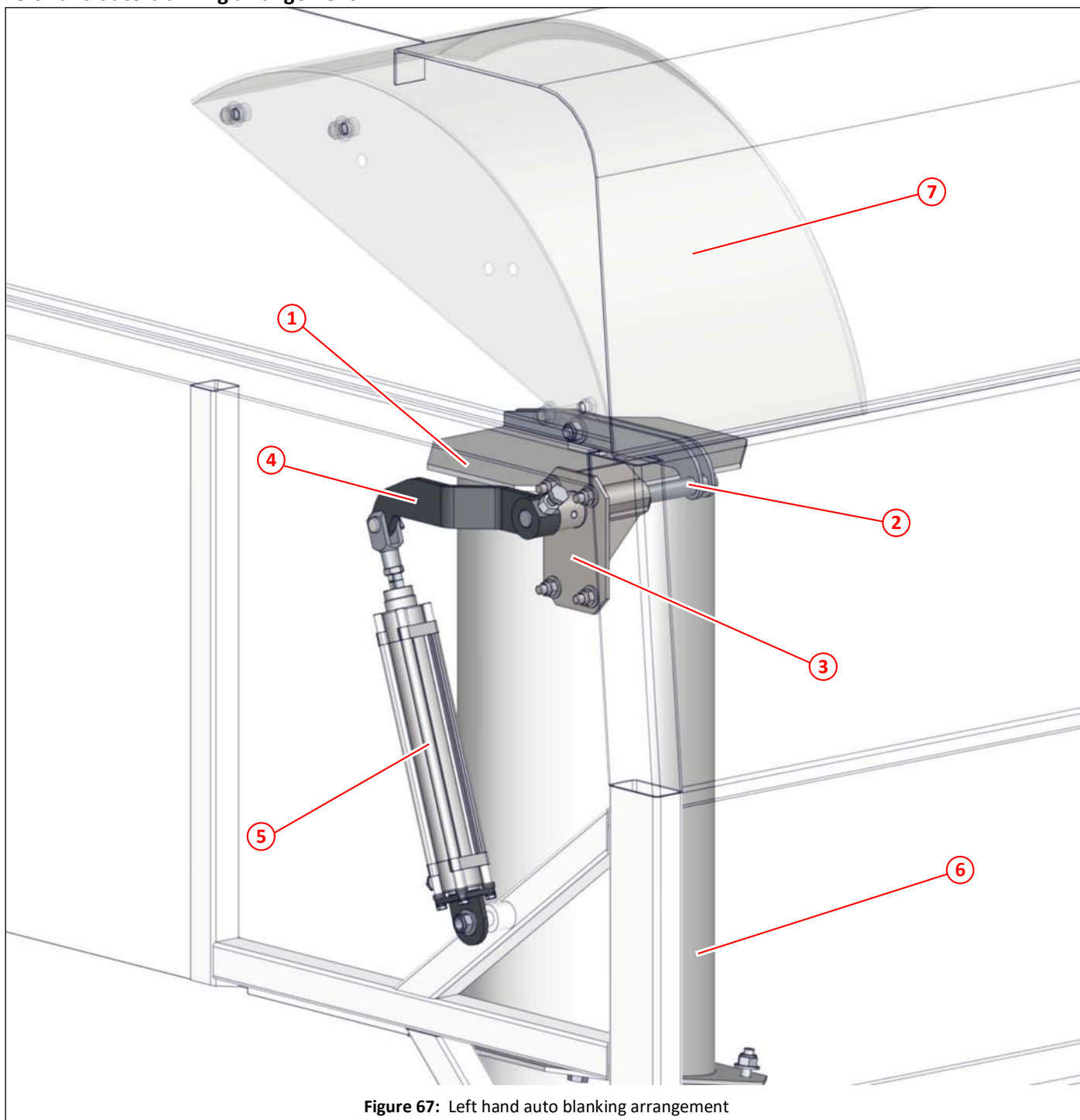

Figure 67: Left hand auto blanking arrangement

Item	Part No	Qty	Description	
①	021514	1	Flap lid, auto blanking	97,141
②	021517	1	Flap arm, auto blanking, left hand	97
③	021164	1	Pivot, auto blanking	97
④	034396	1	Lever arm, auto blanking, left hand	97
⑤	026319	1	Pneumatic cylinder, auto blanking, assembly	97,
⑥	044603	1	Tube, deflector	92,93,94,141
⑦	022644	1	Deflector	93,94,141



Left hand auto blanking

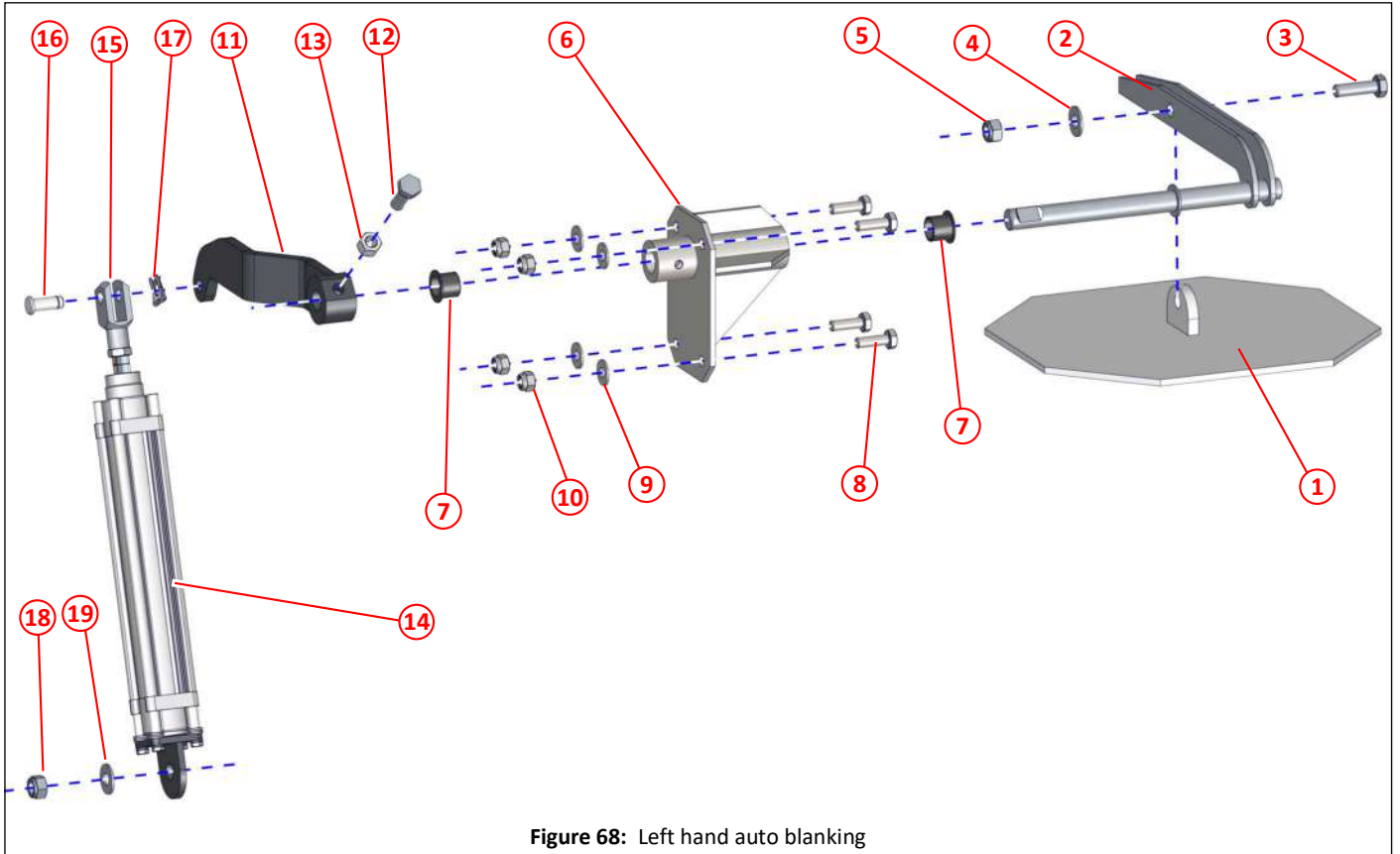

Figure 68: Left hand auto blanking

Item	Part No	Qty	Description	
①	021514	1	Flap lid, auto blanking	93,141
①	050717	1	Flap lid, auto blanking, PU lined	141
②	021517	1	Flap arm, auto blanking, left hand	93
③	000278	1	Set screw M12 x 1.25 x 40, stainless steel	
④	000277	1	Plain washer M12 x 1.25 fine, stainless steel	
⑤	000275	1	Nyloc nut M12, stainless steel	
⑥	021164	1	Pivot, auto blanking	96
⑦	013488	2	Bush	
⑧	011032	4	Set screw M10 x 30	
⑨	011094	4	Plain washer M10	
⑩	011075	4	Nyloc nut M10	
⑪	034396	1	Lever arm, auto blanking, left hand	96
⑫	000276	1	Set screw M12 x 1.25 x 35, stainless steel	
⑬	000279	1	Full nut M12 x 1.25 fine, stainless steel	
⑭	026319	1	Pneumatic cylinder, auto blanking, assembly	312
⑮	014469	1	Clevis	
⑯	02370	1	Clevis pin 12	
⑰	023269	1	Safety fastener 12	
⑱	000275	1	Nyloc nut M12, stainless steel	
⑲	000277	1	Plain washer M12 x 1.25 fine, stainless steel	

Right hand suction nozzle arrangement

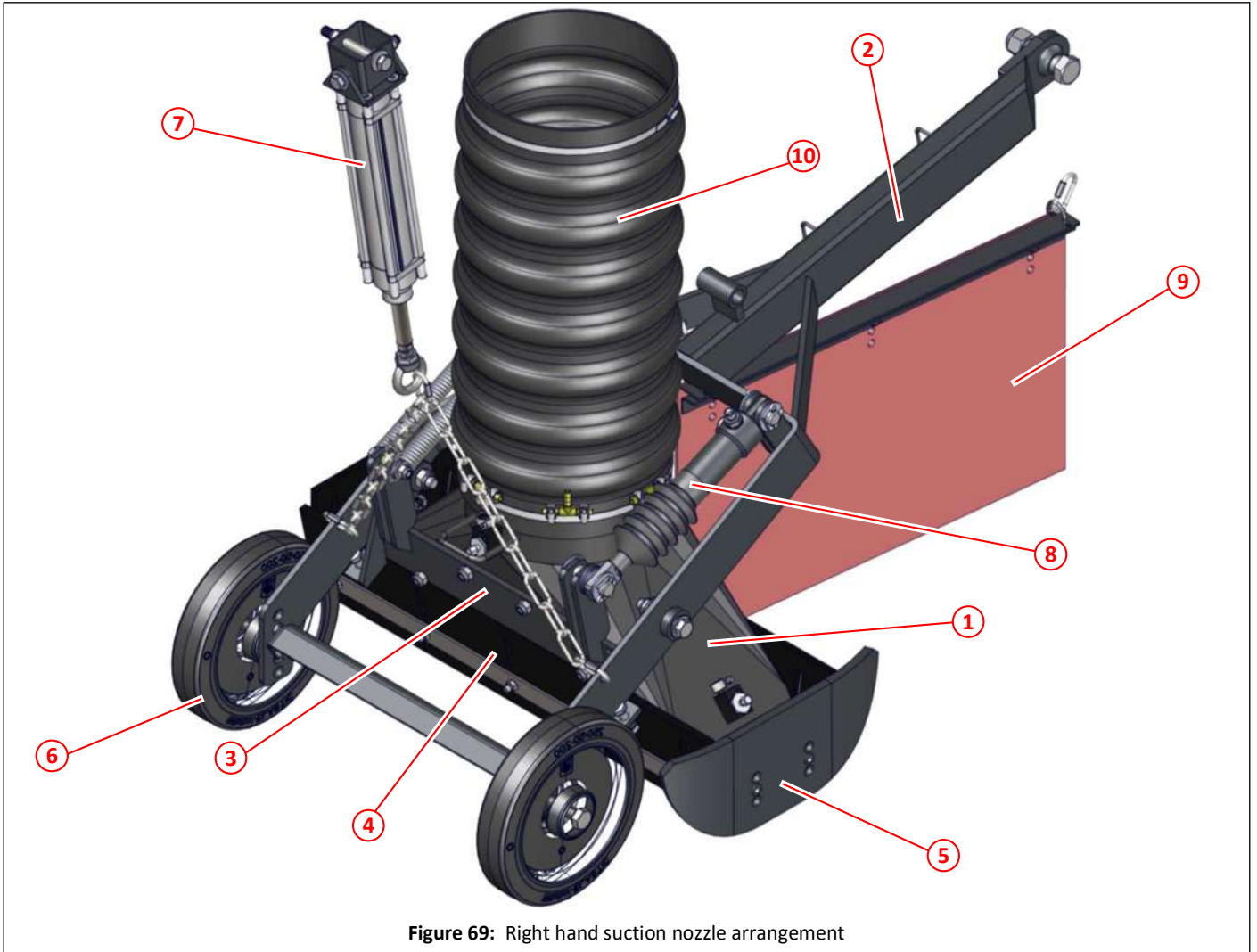

Figure 69: Right hand suction nozzle arrangement

Item	Part No	Qty	Description	
①	023604	1	Suction nozzle box	103,106
②	023606	1	Suction nozzle frame, right hand side	102,103,104,105
③	020328	1	Pivot, suction nozzle	103
④			Suction nozzle flap	106
⑤	013277	1	Skid plate, suction nozzle	110
⑥			Wheel	102
⑦			Suction nozzle lift, pneumatic cylinder	100
⑧			Suction nozzle tilt, hydraulic ram	103,104
⑨			Skirt	101
⑩	013028	1	Suction nozzle hose	99,108

Right hand suction nozzle hose

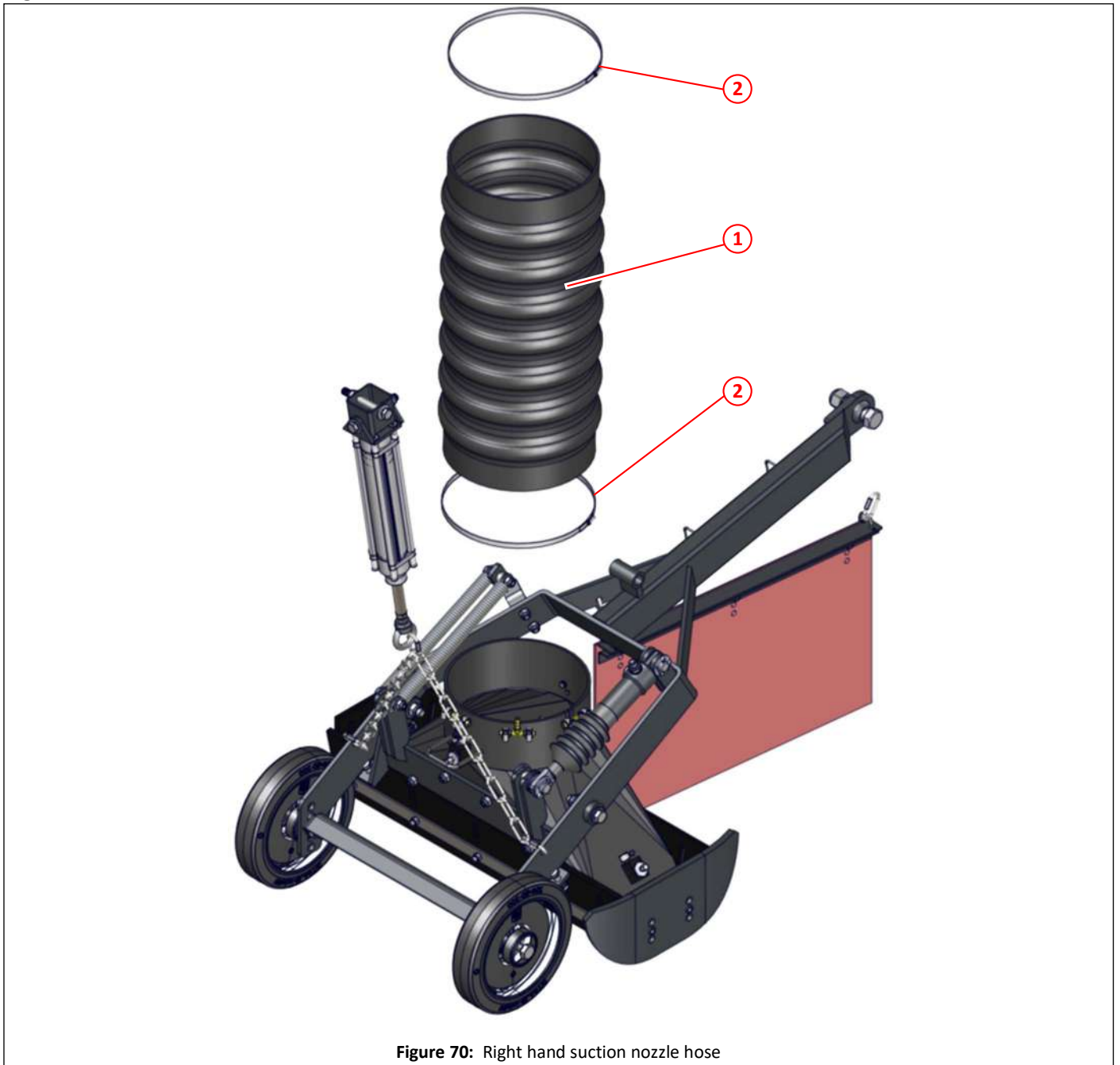

Figure 70: Right hand suction nozzle hose

Item	Part No	Qty	Description	
①	013028	1	Suction nozzle hose	98,108
②	012933	2	Hose clamp, worm drive, No. 10.50 (ø235mm-ø267mm)	

Right hand suction nozzle lift mechanism

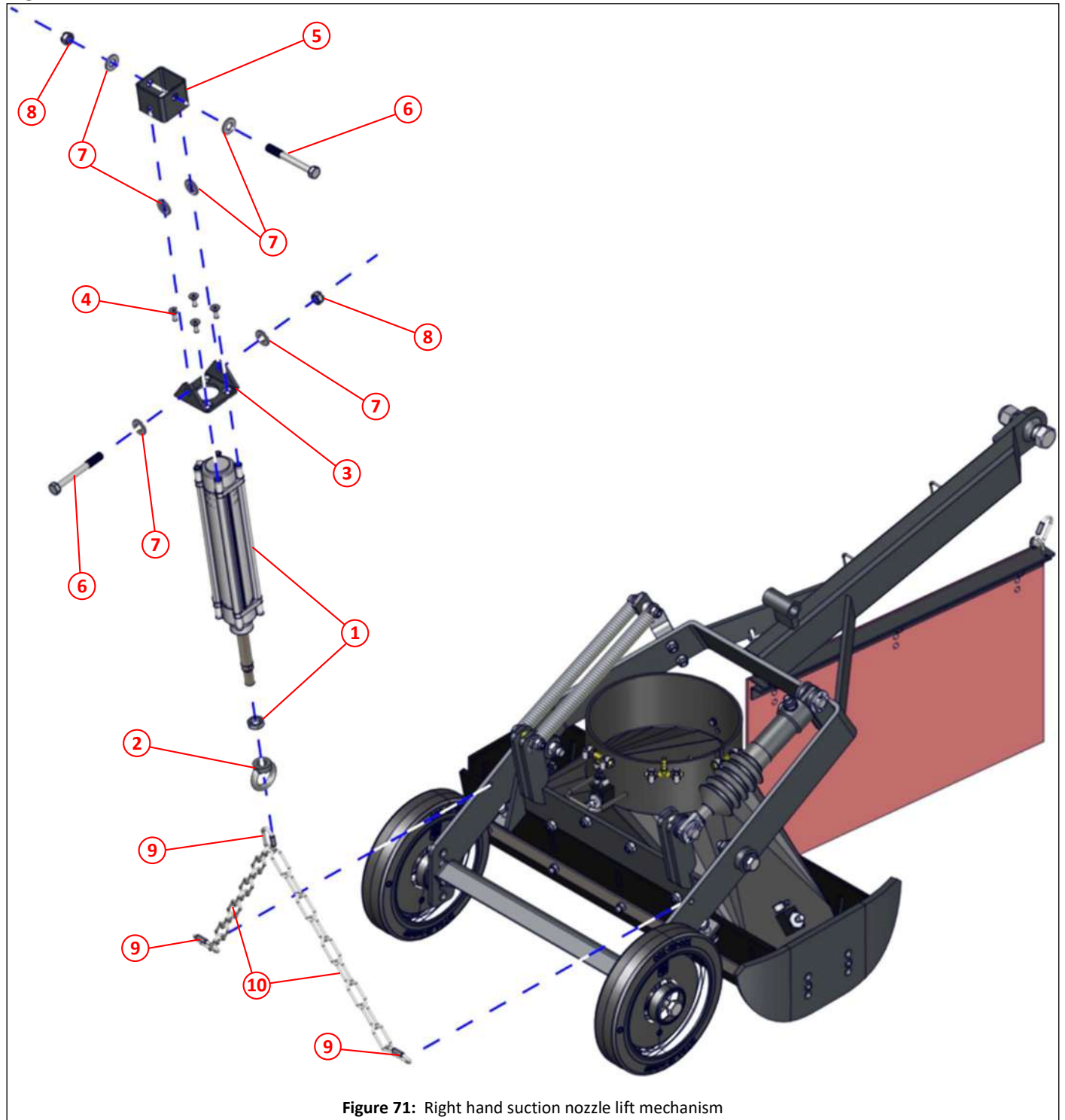

Figure 71: Right hand suction nozzle lift mechanism

Item	Part No	Qty	Description	
①	030772	1	Pneumatic cylinder 50 x 200, suction nozzle lift, includes nut	309
②	032293	1	Ring nut, M16 x 1.5	
③	030777	1	Cylinder pivot, suction nozzle lift	
④	000003	4	Socket countersunk screw M8 x 20, plated	
⑤	030776	1	Cylinder pivot block, suction nozzle lift	
⑥	011057	2	Bolt M12 x 100	
⑦	011096	6	Plain washer M12	
⑧	011077	2	Nyloc nut M12	
⑨	010606	3	Carabiner	
⑩	010525	As req	Chain, large link	

Right hand suction nozzle skirt

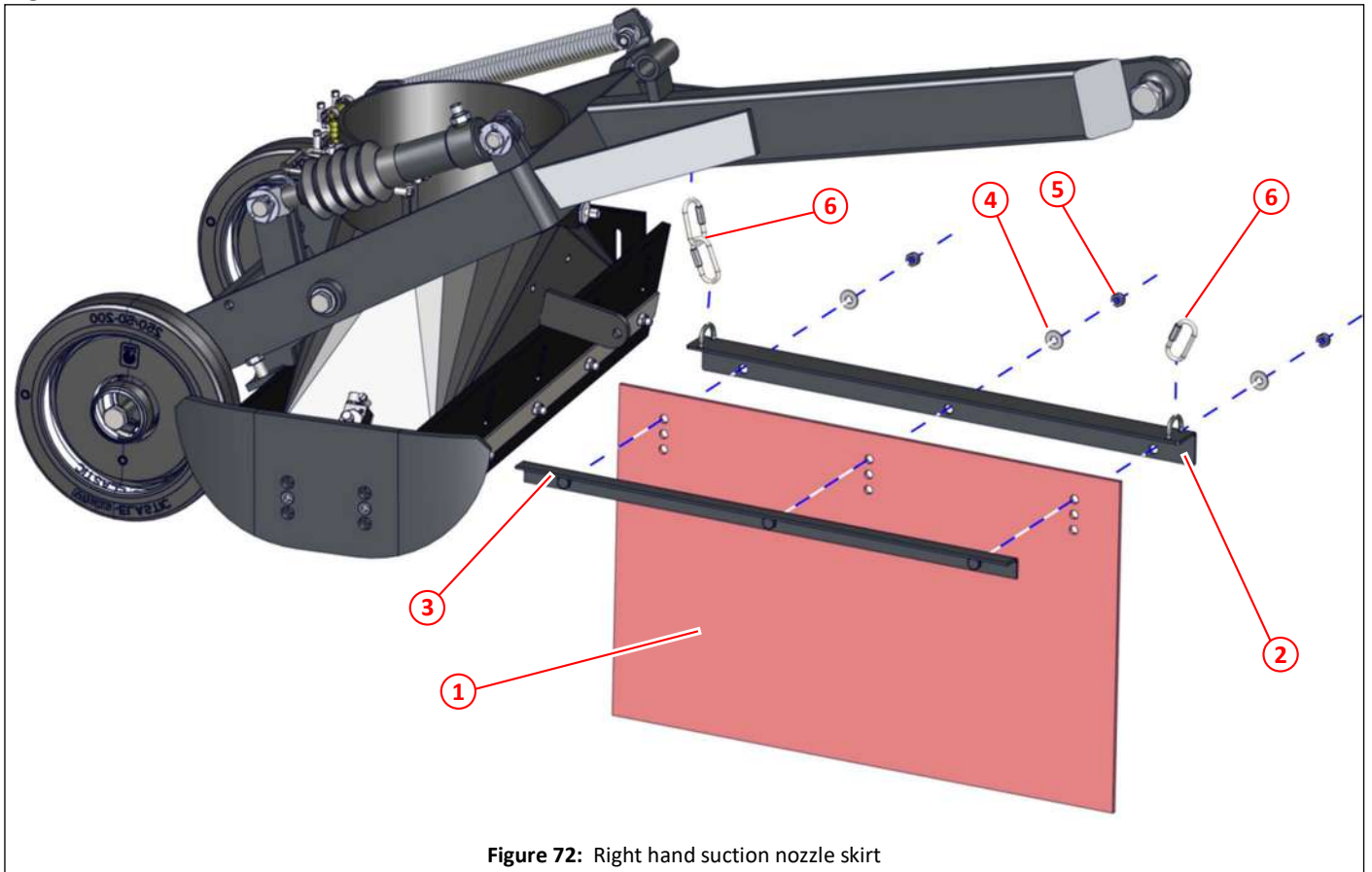

Figure 72: Right hand suction nozzle skirt

Item	Part No	Qty	Description	
①	010247	1	Skirt, 3-pitch, heavy duty	98
②	013145	1	Skirt angle	
③	010275	1	Skirt clamp	
④	011092	3	Plain washer M8	
⑤	011073	3	Nyloc nut M8	
⑥	010606	3	Carabiner	



Right hand suction nozzle frame

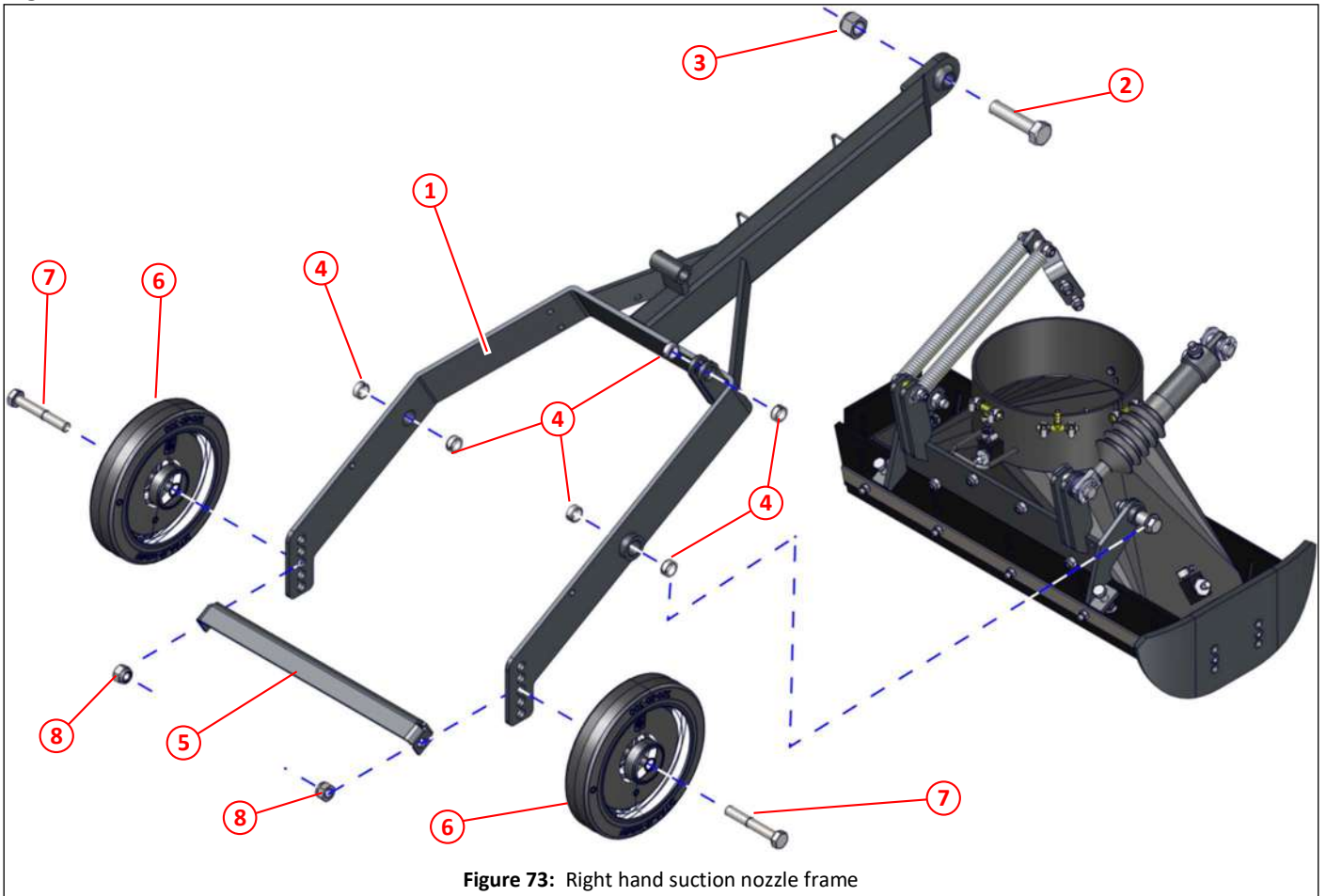

Figure 73: Right hand suction nozzle frame

Item	Part No	Qty	Description	
①	023606	1	Nozzle frame, right hand side	98,103
②	011118	1	Bolt $\frac{7}{8}$ " UNF x $3\frac{1}{2}$ "	
③	011119	1	Nyloc nut $\frac{7}{8}$ " UNF	
④	024682	6	Bush $\varnothing 20$ x $\varnothing 25$ x 10	
⑤	031833	1	Axle, nozzle	
⑥	031831	2	Wheel, nozzle	
⑦	011133	2	Bolt M16 x 100	
⑧	011060	2	Nyloc nut M16	



Right hand suction nozzle tilt pivot

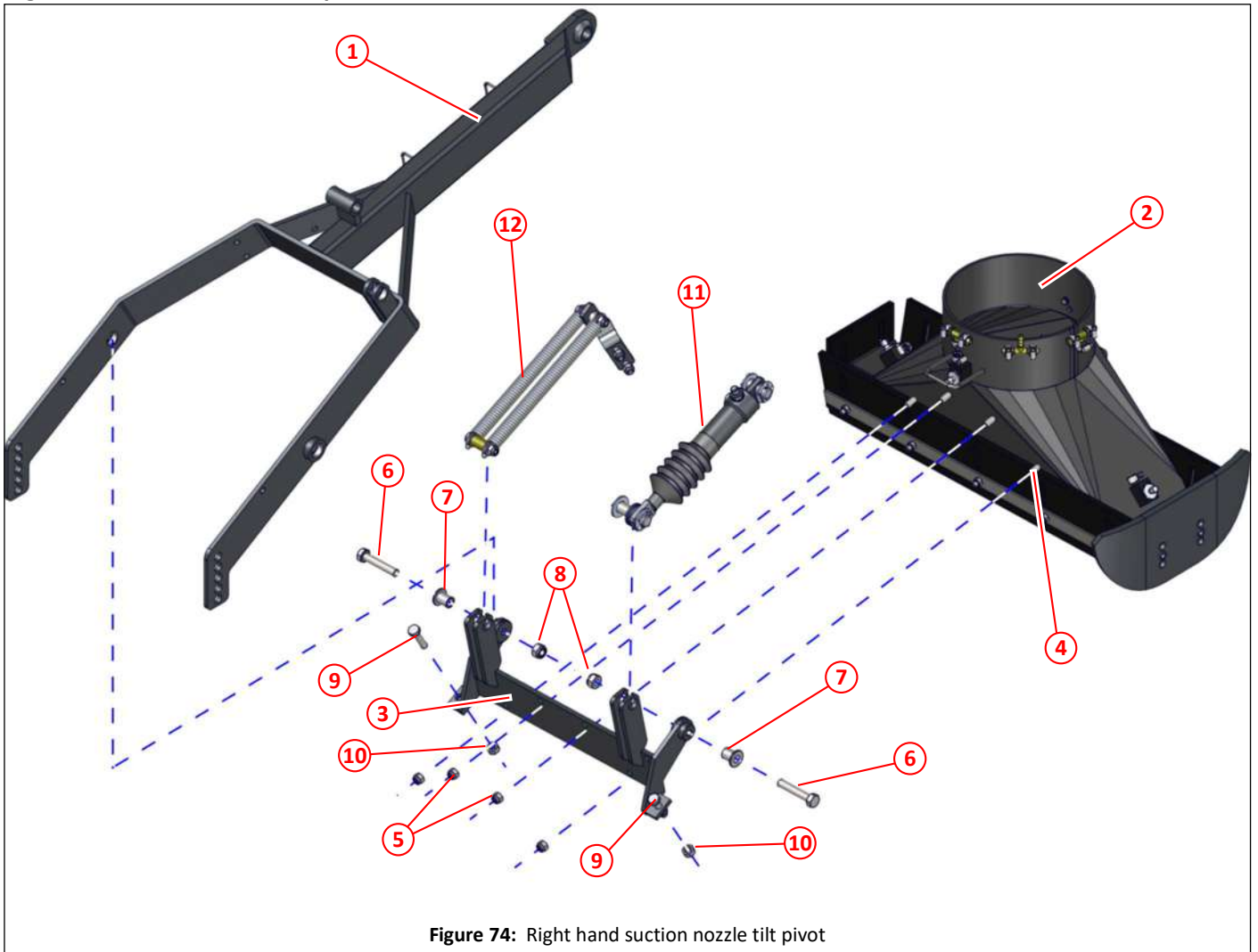

Figure 74: Right hand suction nozzle tilt pivot

Item	Part No	Qty	Description	
①	023606	1	Nozzle frame, right hand side	98,102,104,105
②	023604	1	Suction nozzle	98
②		1	Suction nozzle, PU lined	141
③	020328	1	Pivot, suction nozzle	98
④	011031	4	Set screw M10 x 25	
⑤	011075	4	Nyloc nut M10	
⑥	000351	2	Set screw M14 x 70	
⑦	021416	2	Sleeve	
⑧	011127	2	Nyloc nut M14	
⑨	011054	2	Set screw M12 x 45	
⑩	011076	2	Full nut M12	
⑪			Ram, nozzle tilt	98,104
⑫			Return springs	104,105

Right hand suction nozzle tilt ram

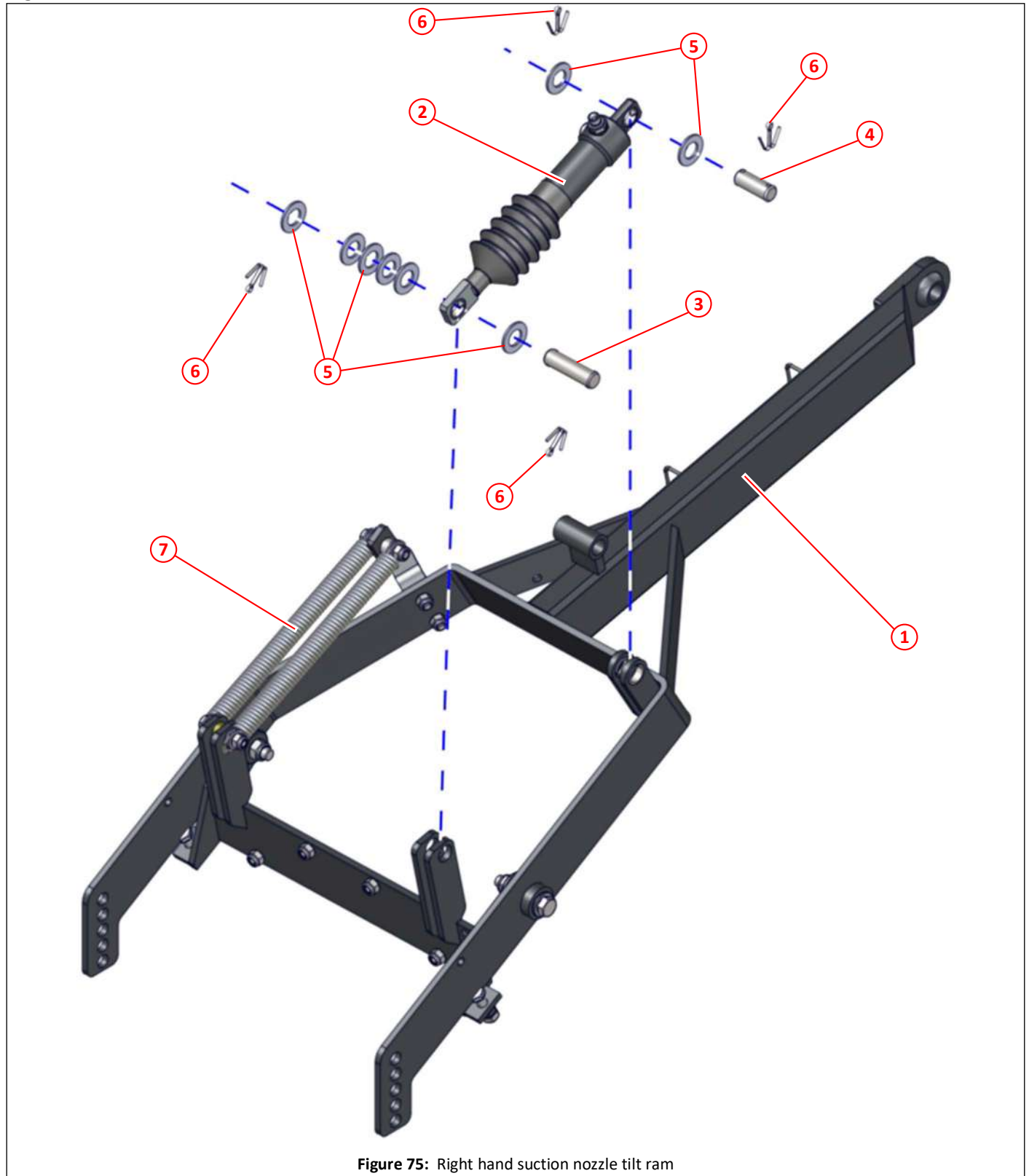

Figure 75: Right hand suction nozzle tilt ram

Item	Part No	Qty	Description	
①	023606	1	Nozzle frame, right hand side	98,102,103,105
②	041955	1	Ram, nozzle tilt assembly	98,103,274
③	014038	1	Pin $\phi 20 \times 70$	
④	010067	1	Pin $\phi 20 \times 50$	
⑤	011102	8	Plain washer M20	
⑥	011122	4	Split pin $\frac{3}{16}'' \times 1\frac{1}{2}''$	
⑦			Return spring	105

Right hand suction nozzle tilt return springs

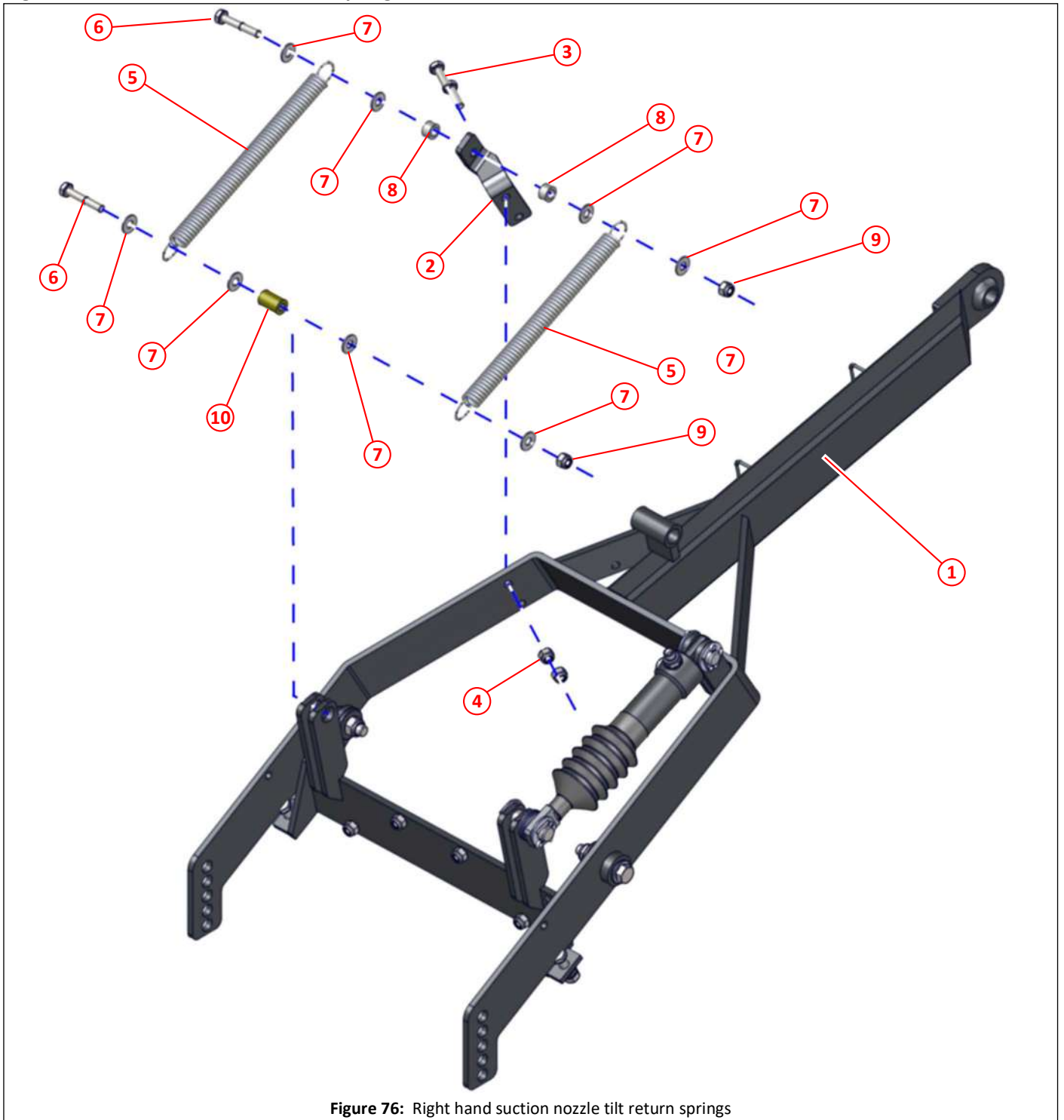

Figure 76: Right hand suction nozzle tilt return springs

Item	Part No	Qty	Description	
①	023606	1	Nozzle frame, right hand side	98,102,103,104
②	025099	1	Bracket, return spring	
③	011032	2	Set screw M10 x 30	
④	011075	2	Nyloc nut M10	
⑤	010017	2	Return spring	104
⑥	000040	2	Bolt M10 x 55	
⑦	011094	8	Plain washer M10	
⑧	011724	2	Spacer $\phi 12.5 \times \phi 20 \times 11$	
⑨	011075	2	Nyloc nut M10	
⑩	013363	1	Sleeve, spacer	

Right hand suction nozzle, flaps and skid plate

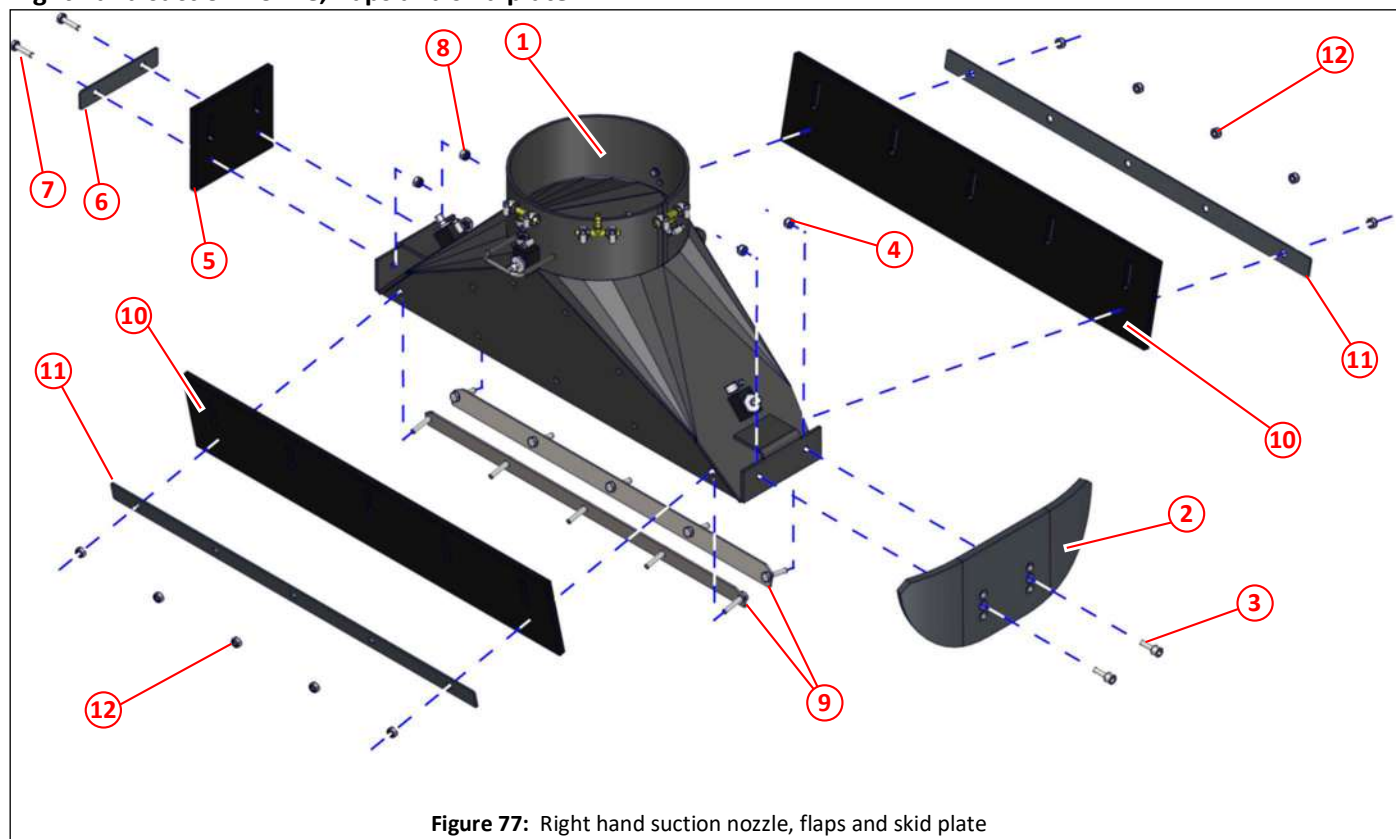

Figure 77: Right hand suction nozzle, flaps and skid plate

Item	Part No	Qty	Description	
①	023604	1	Suction nozzle	98,105
①		1	Suction nozzle, PU lined	141
②	013277	1	Skid plate, suction nozzle	98
③	011021	2	Socket cap screw M8 x 25	
④	011073	2	Nyloc nut M8	
⑤	013283	1	Flap, side, suction nozzle	
⑥	013024	1	Clamp, flap, side, suction nozzle	
⑦	011012	2	Set screw M8 x 30	
⑧	011073	2	Nyloc nut M8	
⑨	013362	2	Bolt retainer, flap, suction nozzle	
⑩	013023	2	Flap, front/rear, suction nozzle	
⑪	013025	2	Clamp, flap, front/rear, suction nozzle	
⑫	011073	10	Nyloc nut M8	
NI	024550		Flap kit, items ⑤ and 2 x ⑩	

Right hand suction spigot, deflector and blanking arrangement

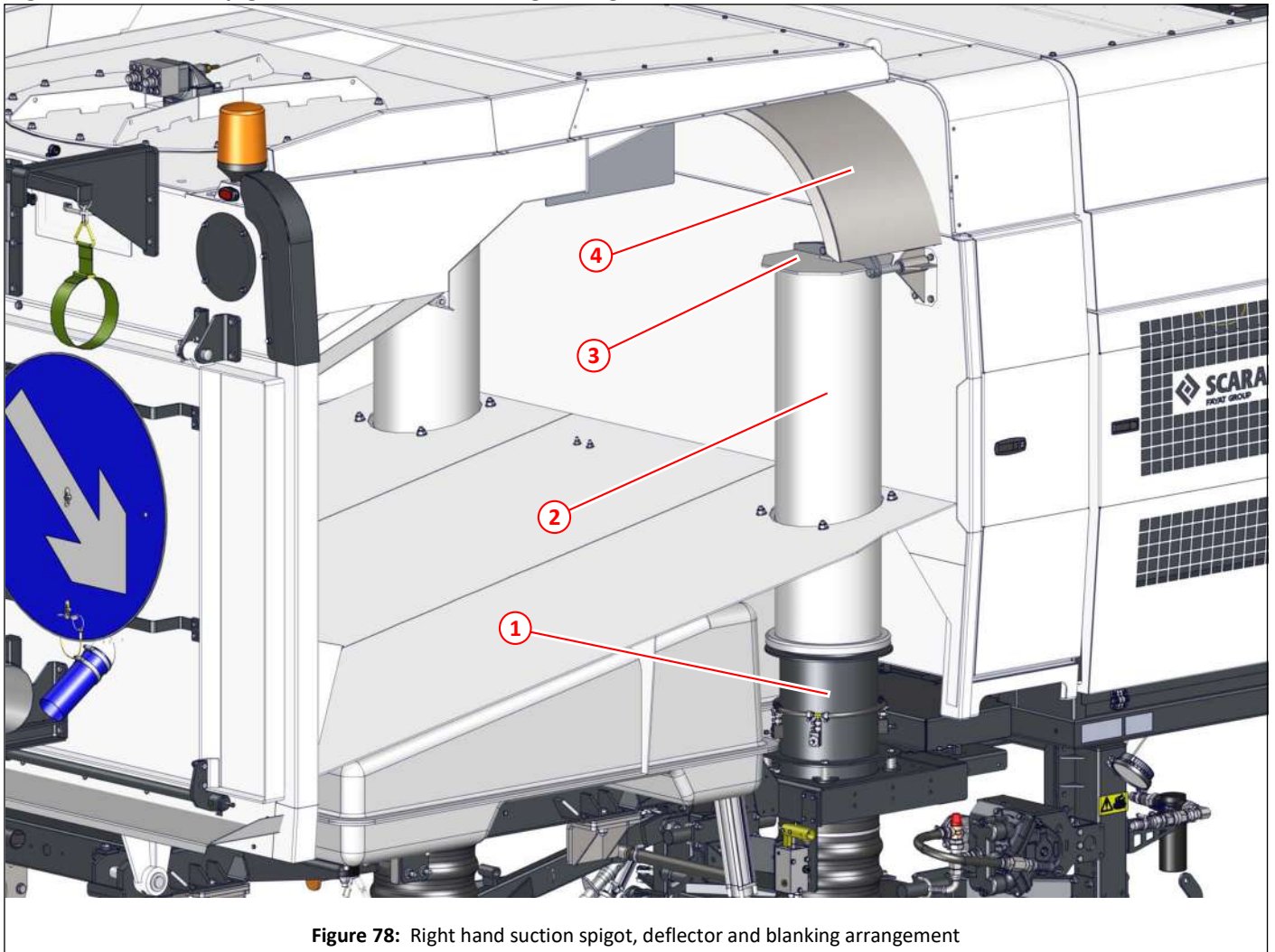

Figure 78: Right hand suction spigot, deflector and blanking arrangement

Item	Part No	Qty	Description	
①	043043	1	Suction spigot	108,109
②	044603	1	Tube, deflector	108,109,110,111,113
③			Auto blanking, right hand	110,111,113,114
④	022644	1	Deflector	108,109,110,111,113



Suction spigot arrangement

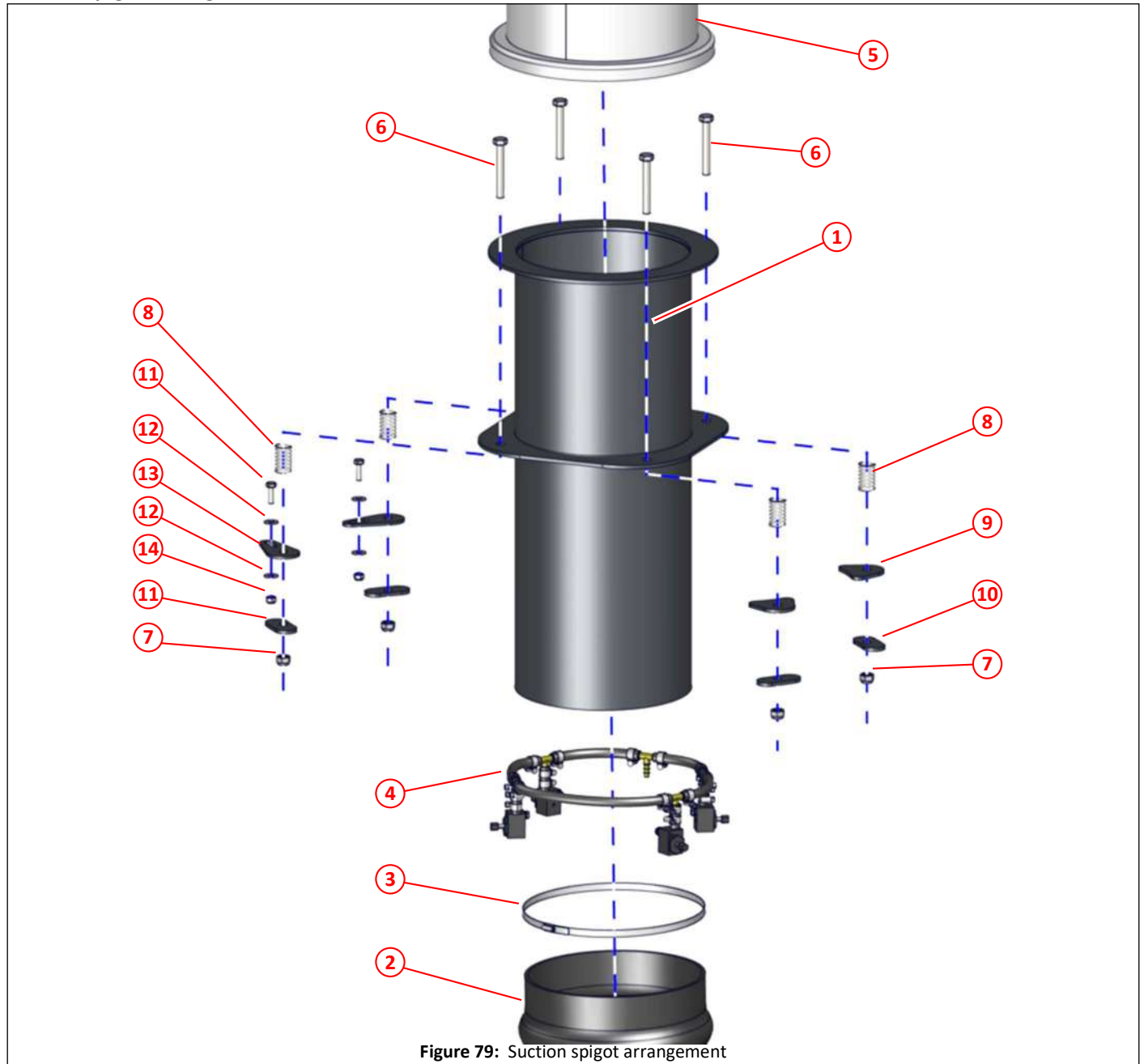

Figure 79: Suction spigot arrangement

Item	Part No	Qty	Description	
①	043043	1	Suction spigot	107,109,141
②	013028	1	Suction nozzle hose	98,99
③	012933	2	Hose clamp, worm drive, No. 10.50 (ø235mm-ø267mm)	
④			Additional water jets	228
⑤	044603	1	Tube, deflector	107,109,110,111,113,141
⑥	000110	4	Bolt M12 x 80	
⑦	011077	4	Nyloc nut M12	
⑧	042694	4	Spring	
⑨	0430443	2	Spring seat, suction spigot	
⑩	039989	2	Washer, special	
⑪	011011	2	Set screw M8 x 25	
⑫	011092	4	Plain washer M8	
⑬	043392	2	Locking washer, suction spigot	
⑭	011073	2	Nyloc nut M8	



Suction deflector tube

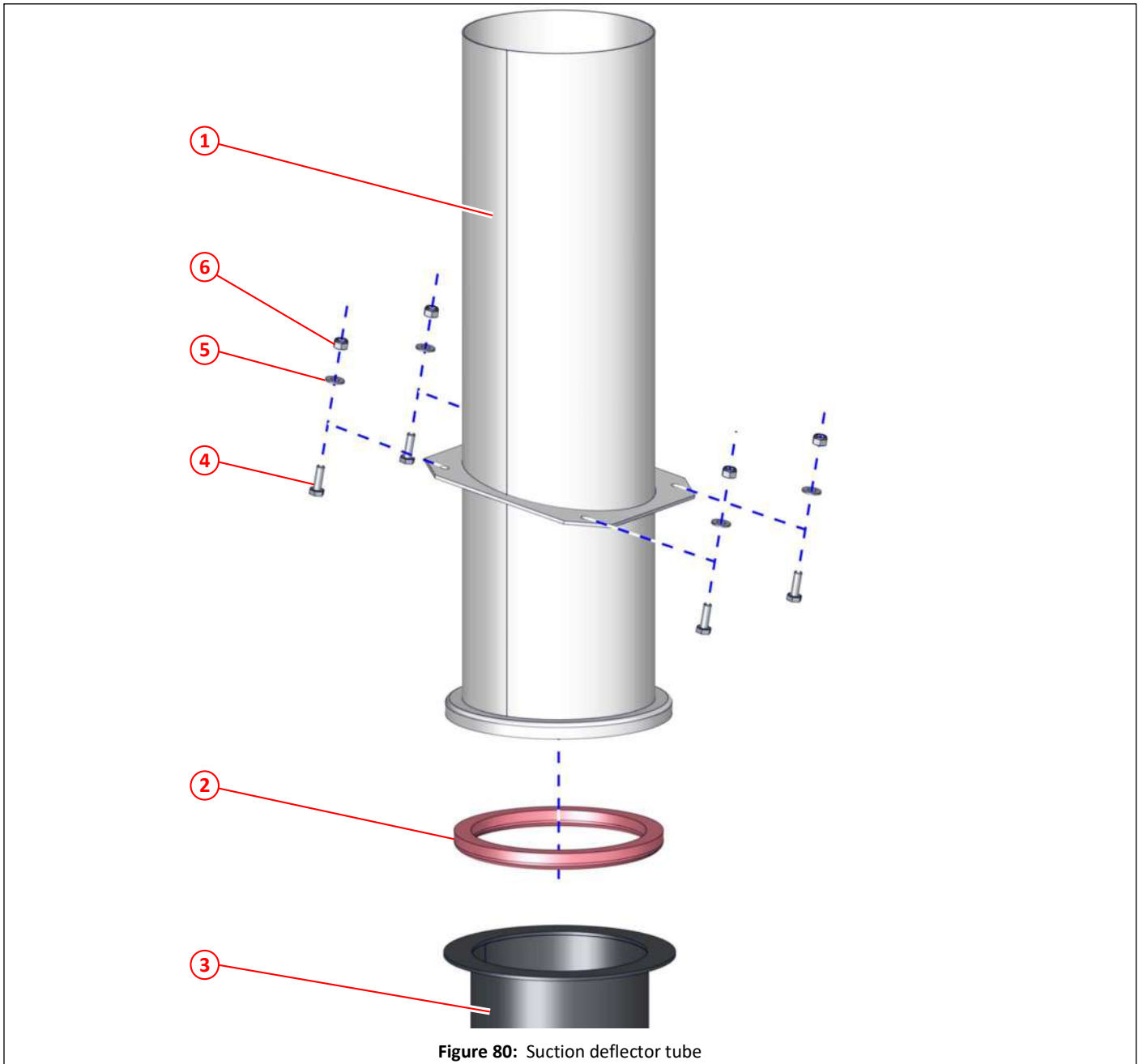
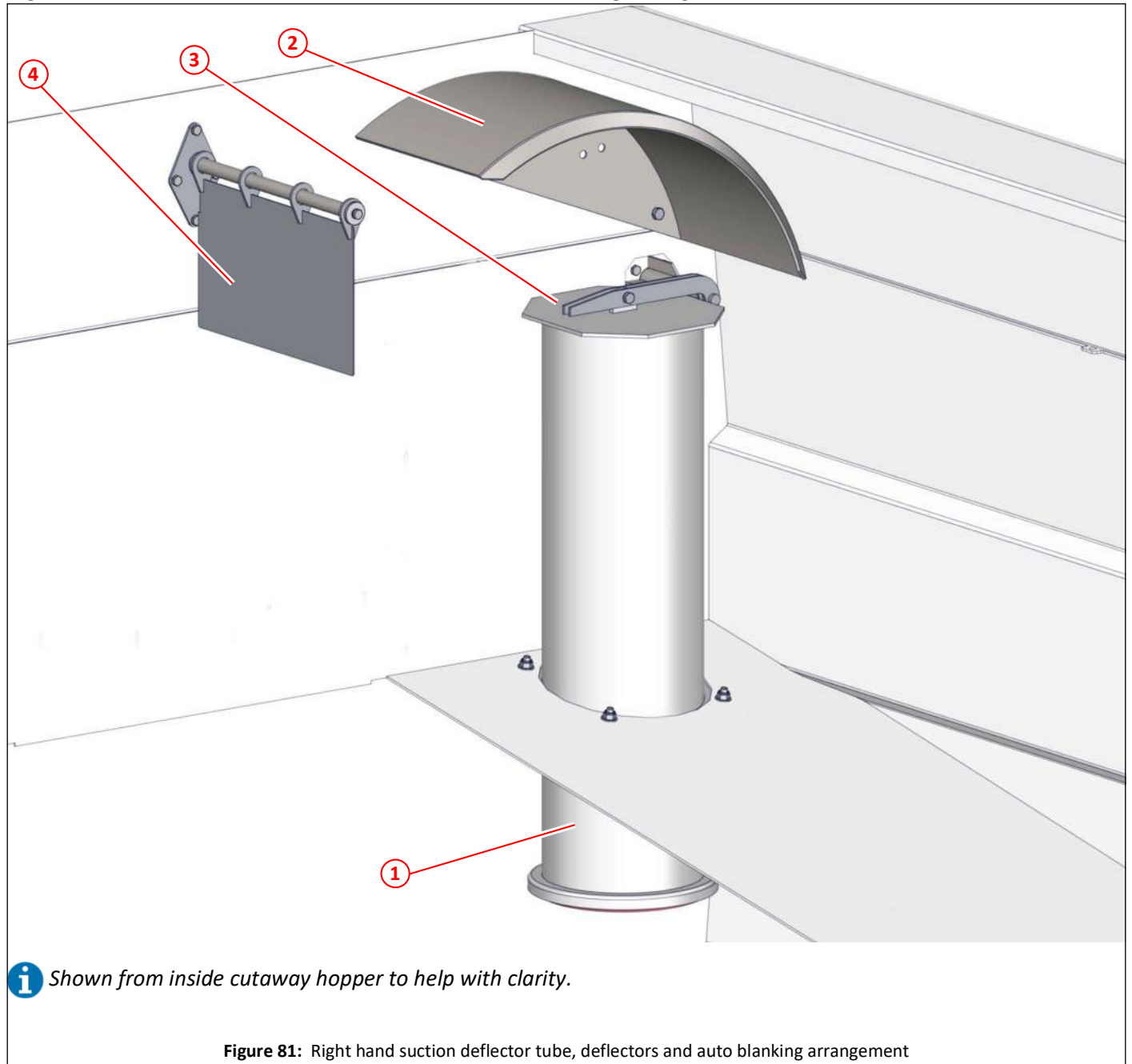

Figure 80: Suction deflector tube

Item	Part No	Qty	Description	
①	044603	1	Tube, deflector	107,108,110,111,113,170
①	051137	1	Tube, deflector, PU lined	141
②	013601	1	Seal, tube deflector	
③	043043	1	Suction spigot	107,108
④	000285	4	Set screw M12 x 35, stainless steel	
⑤	000277	4	Plain washer M12, stainless steel	
⑥	000275	4	Nyloc nut M12, stainless steel	

Right hand suction deflector tube, deflectors and auto blanking arrangement



Item	Part No	Qty	Description	
①	044603	1	Tube, deflector	107,108,109,111,113,141
②	022644	1	Deflector	107,108,109,111,113,141
③			Auto blanking flap, right hand	107,111,113,114
④			Deflector swing plate	111,112

Right hand deflector arrangement

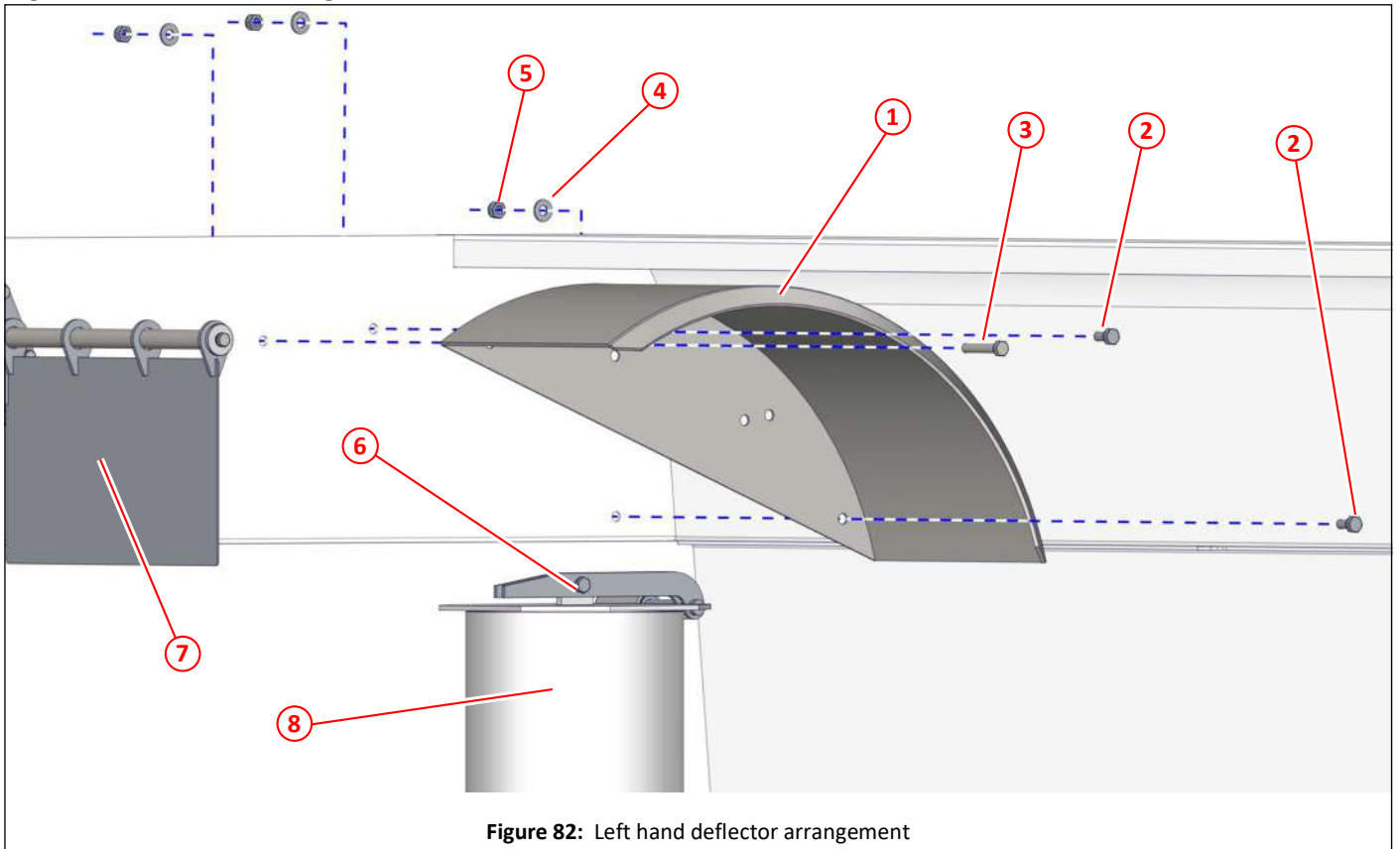

Figure 82: Left hand deflector arrangement

Item	Part No	Qty	Description	
①	022644	1	Deflector	108,109,110,113,141
②	000273	2	Set screw M12 x 25, stainless steel	
③	011056	1	Bolt M12 x 70	
④	000277	4	Plain washer M12, stainless steel	
⑤	000275	4	Nyloc nut M12, stainless steel	
⑥			Auto blanking flap, right hand	107,110,113,114,141
⑦			Deflector swing plate	110,112,141
⑧	044603	1	Tube, deflector	107,108,109,110,113,141

Deflector swing plate arrangement

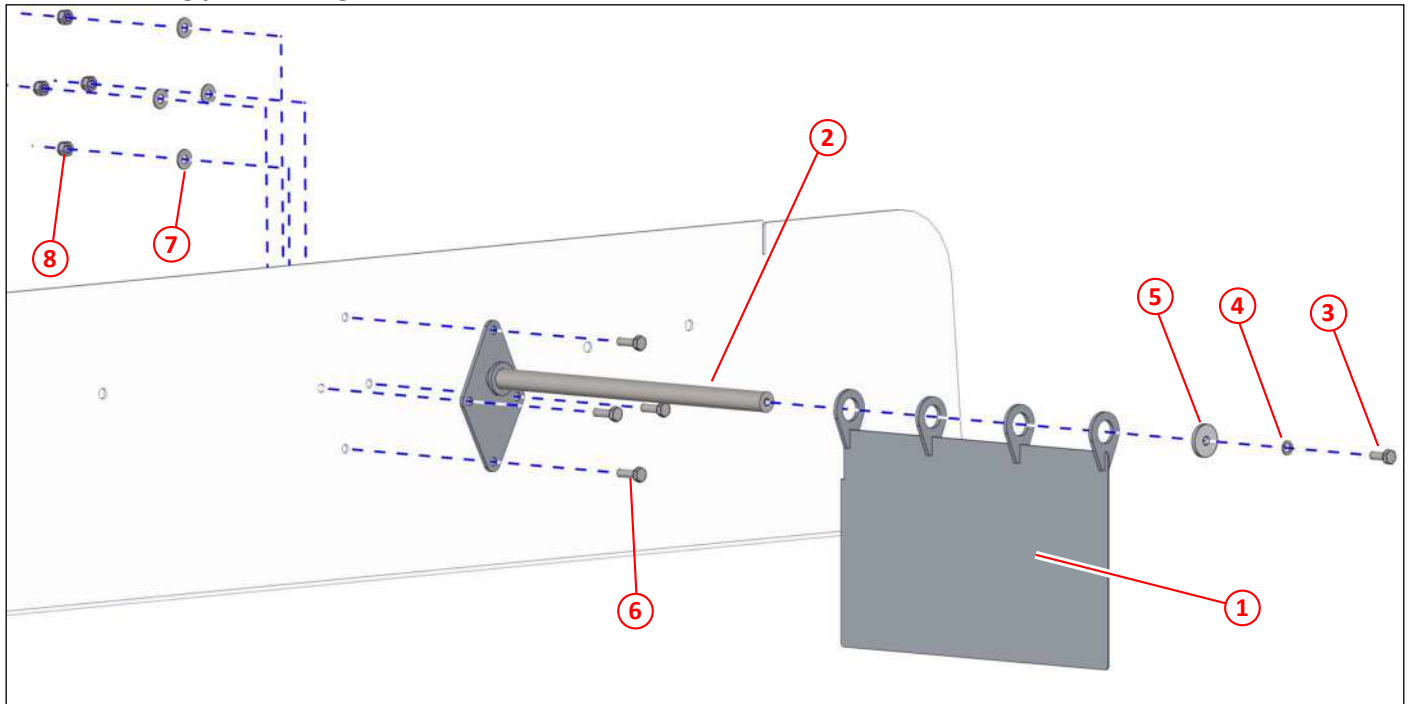

Figure 83: Deflector swing plate arrangement

Item	Part No	Qty	Description	
①	044618	1	Deflector swing plate	110,111
①	044606	1	Deflector swing plate, PU lined	141
②	044605	1	Mounting bar, deflector flap	
③	011031	1	Set screw M10 x 25	
④	011095	1	Spring washer M10	
⑤	030537	1	Washer $\phi 10.5 \times \phi 40 \times 5$	
⑥	011032	4	Set screw M10 x 30	
⑦	011094	4	Plain washer M10	
⑧	011075	4	Nyloc nut M10	

Right hand auto blanking arrangement

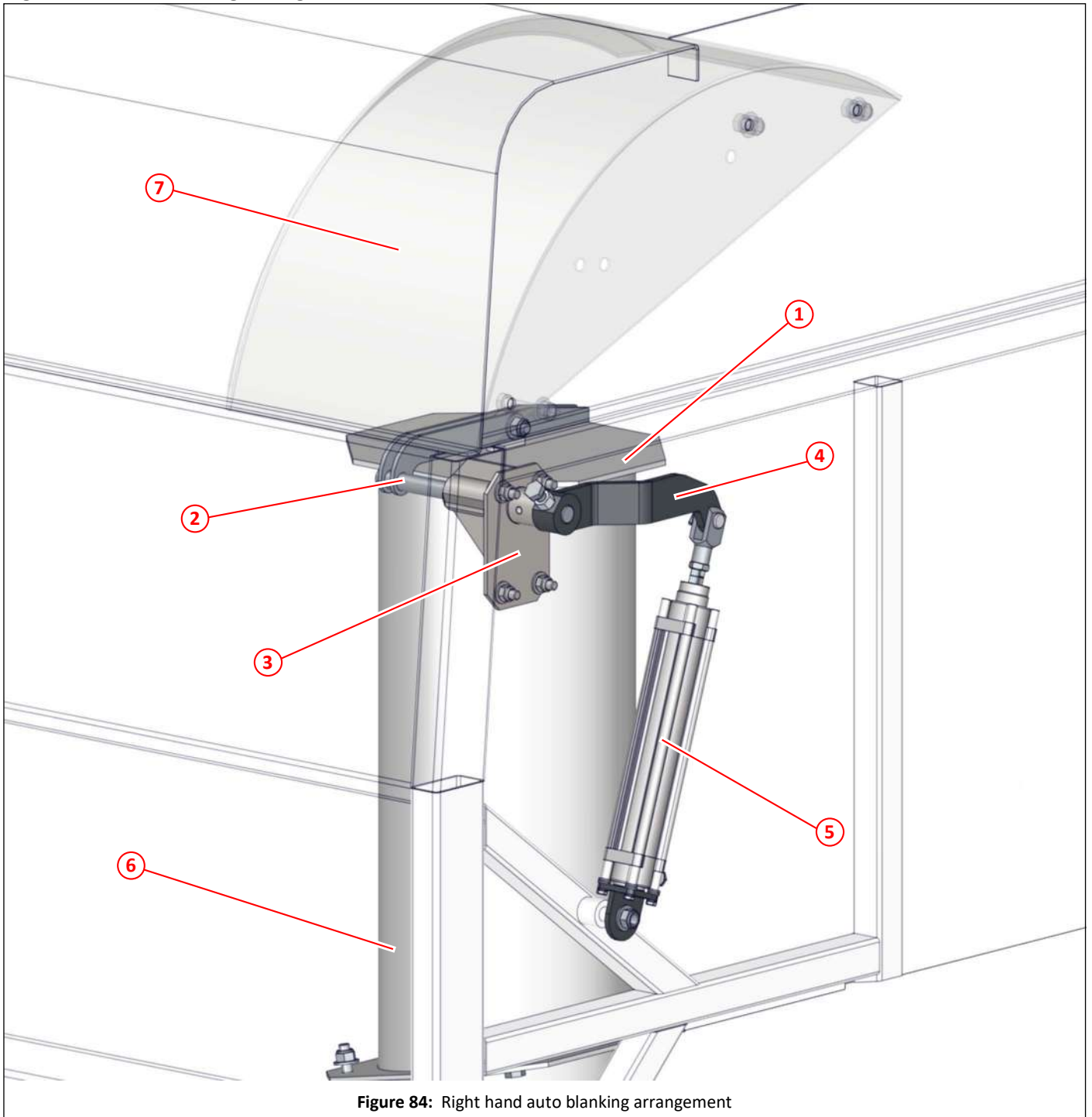

Figure 84: Right hand auto blanking arrangement

Item	Part No	Qty	Description	
①	021514	1	Flap lid, auto blanking	107,110,111,114,170,141
②	021518	1	Flap arm, auto blanking, right hand	114
③	021164	1	Pivot, auto blanking	114
④	034397	1	Lever arm, auto blanking, right hand	114
⑤	026319	1	Pneumatic cylinder, auto blanking, assembly	114
⑥	044603	1	Tube, deflector	107,108,109,110,111,141
⑦	022644	1	Deflector	108,109,110,111,141

Right hand auto blanking

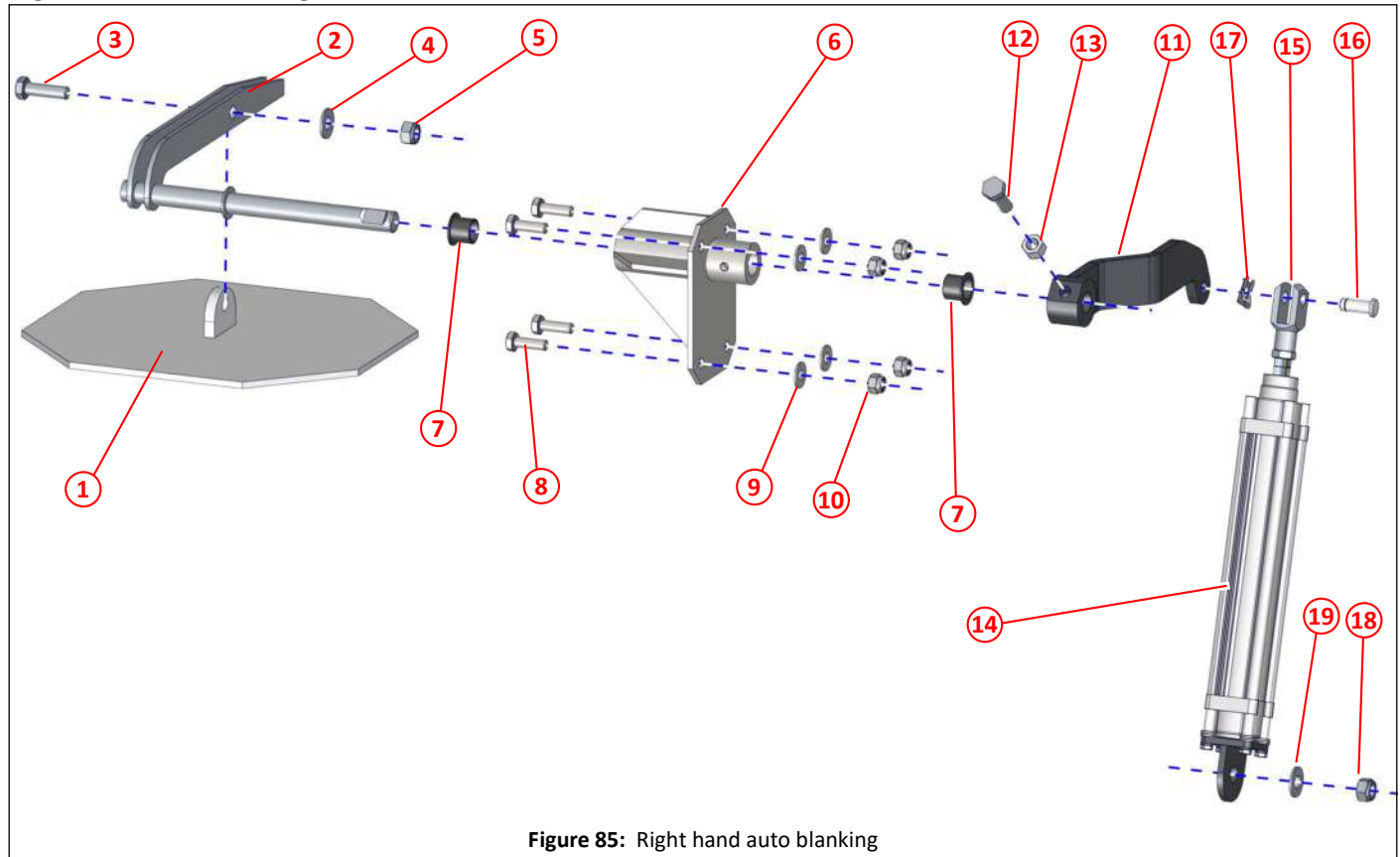

Figure 85: Right hand auto blanking

Item	Part No	Qty	Description	
①	021514	1	Flap lid, auto blanking	107,110,111,113
①	050717	1	Flap lid, auto blanking, PU lined	141
②	021518	1	Flap arm, auto blanking, right hand	113
③	000278	1	Set screw M12 x 1.25 x 40, stainless steel	
④	000277	1	Plain washer M12 x 1.25 fine, stainless steel	
⑤	000275	1	Nyloc nut M12, stainless steel	
⑥	021164	1	Pivot, auto blanking	113
⑦	013488	2	Bush	
⑧	011032	4	Set screw M10 x 30	
⑨	011094	4	Plain washer M10	
⑩	011075	4	Nyloc nut M10	
⑪	034397	1	Lever arm, auto blanking, right hand	113
⑫	000276	1	Set screw M12 x 1.25 x 35, stainless steel	
⑬	000279	1	Full nut M12 x 1.25 fine, stainless steel	
⑭	026319	1	Pneumatic cylinder, auto blanking, assembly	312
⑮	014469	1	Clevis	
⑯	02370	1	Clevis pin 12	
⑰	023269	1	Safety fastener 12	
⑱	000275	1	Nyloc nut M12, stainless steel	
⑲	000277	1	Plain washer M12 x 1.25 fine, stainless steel	



Left hand rear wander hose arrangement

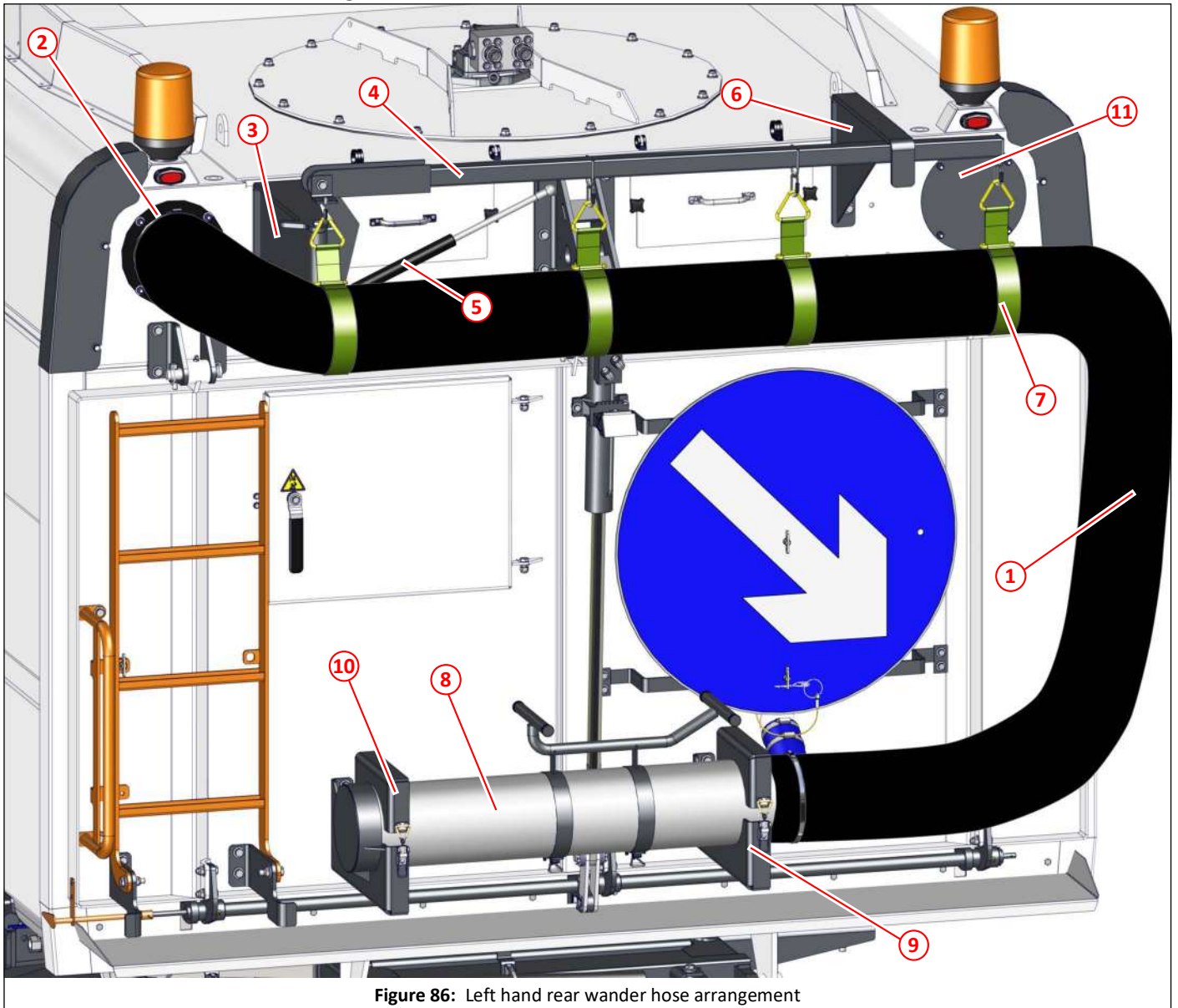

Figure 86: Left hand rear wander hose arrangement

Item	Part No	Qty	Description	
①	036062	3m	Wander hose $\phi$ 180	118
②	025225	1	Spigot sleeve, wander hose	116
③	034312	1	Boom hinge, left hand	117
④	0252218	1	Boom, support, wander hose	117
⑤	021993	1	Gas strut	117
⑥	034313	1	Stowage hook, wander boom	117
⑦	025235	4	Straps, wander hose	117
⑧	035959	1	Tube, wander hose	118
⑨		1	Stowage bracket, wander hose tube	118
⑩		1	Stowage cup, wander hose tube	118
⑪	025486	1	Cover, wander hose duct	159

Left hand rear wander hose, spigot sleeve

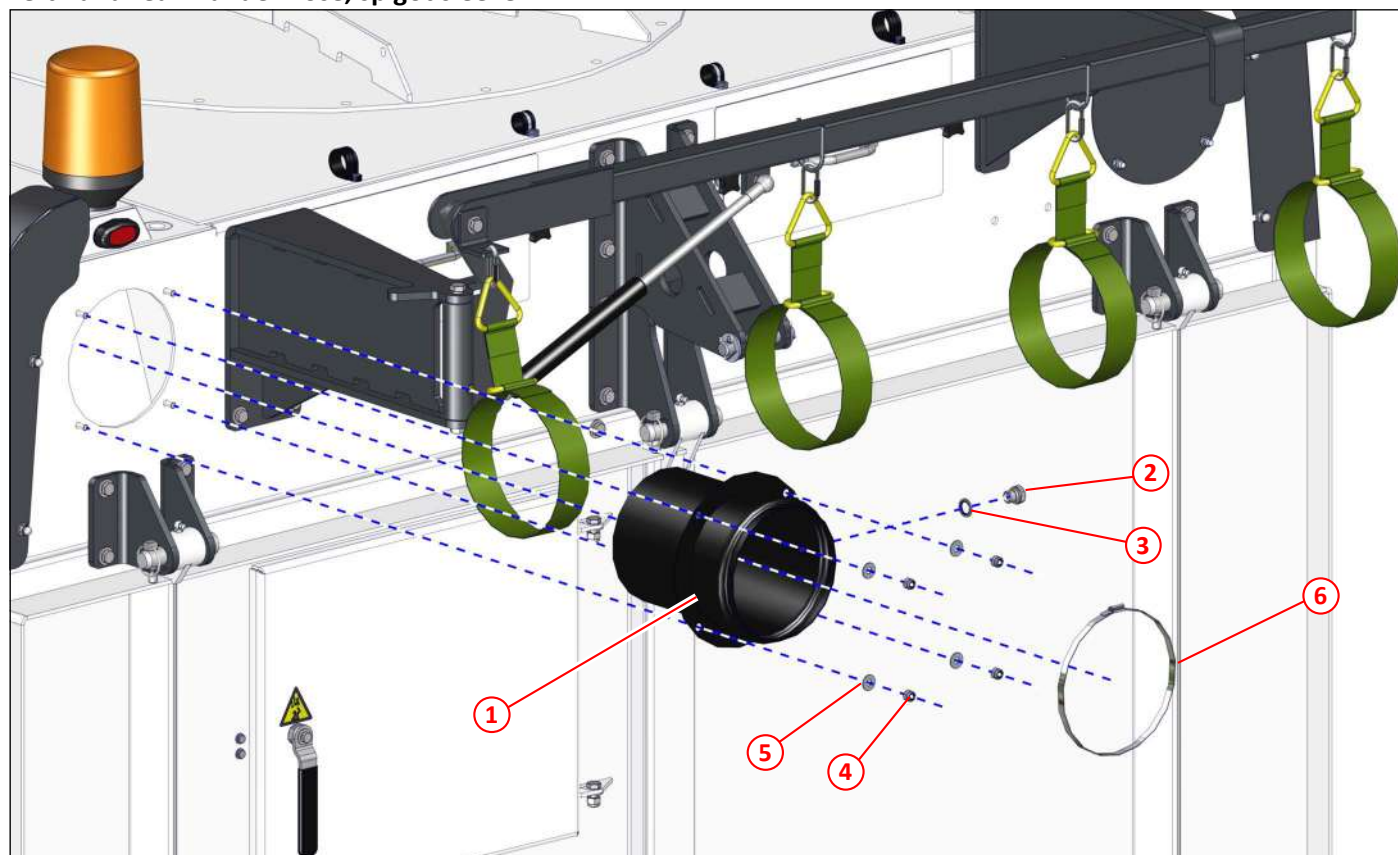

Figure 87: Left hand rear wander hose, spigot sleeve

Item	Part No	Qty	Description	
①	025225	1	Spigot sleeve, rear wander hose	115
②	011242	1	Plug $\frac{3}{8}$ " BSP	
③	011153	1	Dowty seal $\frac{3}{8}$ " BSP	
④	000263	4	Nyloc nut M8, stainless steel	
⑤	000264	4	Plain washer M8, stainless steel	
⑥	012932	1	Hose clamp, worm drive, No. 8.50 ( $\phi$ 184mm- $\phi$ 216mm)	

Left hand rear wander hose, boom

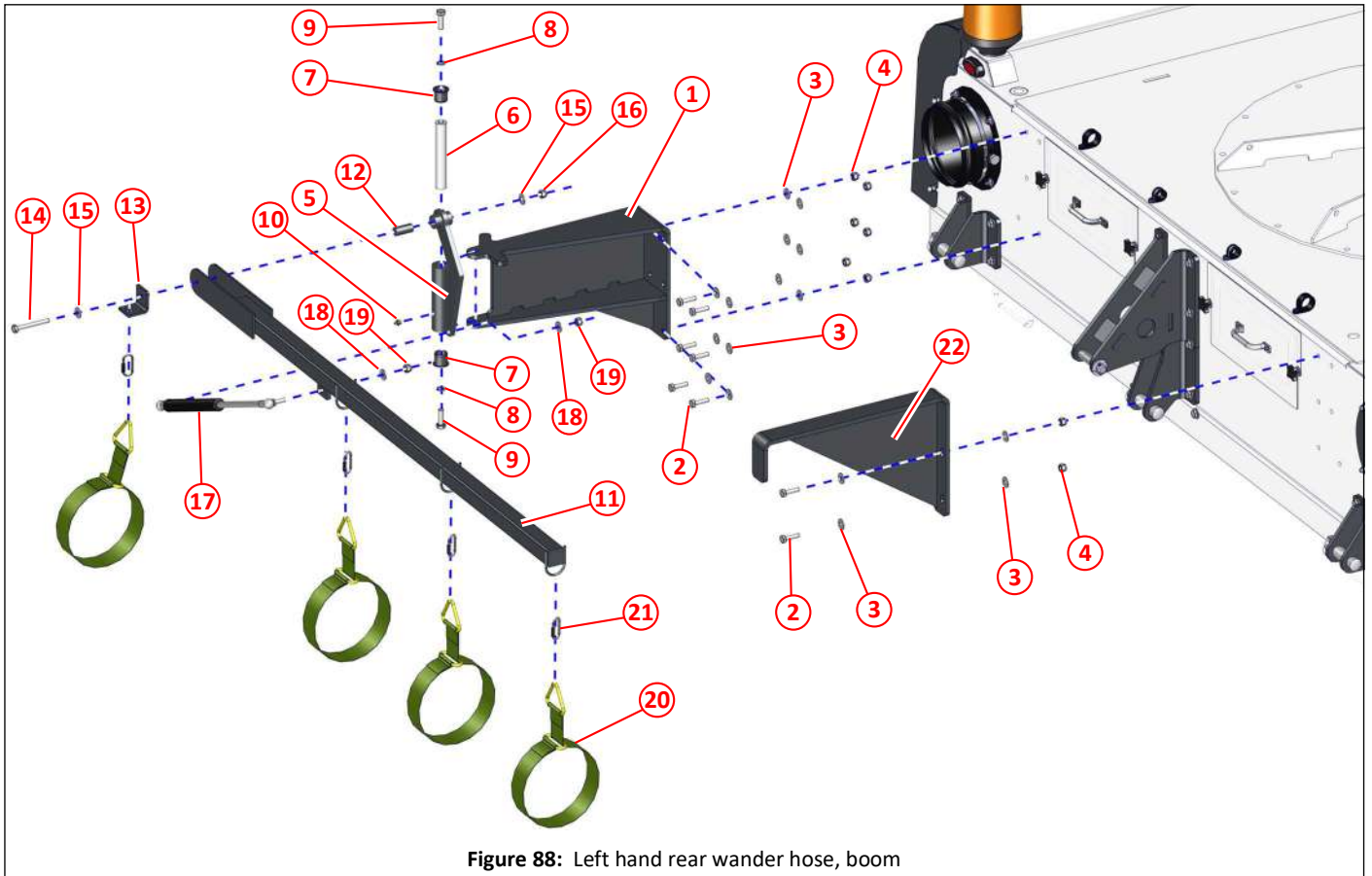

Figure 88: Left hand rear wander hose, boom

Item	Part No	Qty	Description
①	034312	1	Bracket, wander hose boom hinge, left hand
②	011033	8	Set screw M10 x 35
③	011094	16	Plain washer M10
④	011075	8	Nyloc nut M10
⑤	025219	1	Hinge, wander hose boom
⑥	023490	1	Shaft, wander hose boom hinge
⑦	013662	2	Bush
⑧	011097	2	Spring washer M12
⑨	011053	2	Set screw M12 x 35
⑩	010903	1	Grease nipple $\frac{1}{8}$ " BSP, straight
⑪	025218	1	Boom, support wander hose
⑫	014399	1	Spacer, sleeve $\varnothing 10.5 \times \varnothing 20 \times 41$
⑬	012548	1	Bracket, angle
⑭	011038	1	Bolt M10 x 80
⑮	011094	2	Plain washer M10
⑯	011075	1	Nyloc nut M10
⑰	021993	1	Gas strut
⑱	011094	2	Plain washer M10
⑲	011075	2	Nyloc nut M10
⑳	025235	4	Strap, wander hose
㉑	010606	4	Carabiner
㉒	034313	1	Hook, boom stowage

Left hand rear wander hose, nozzle stowage

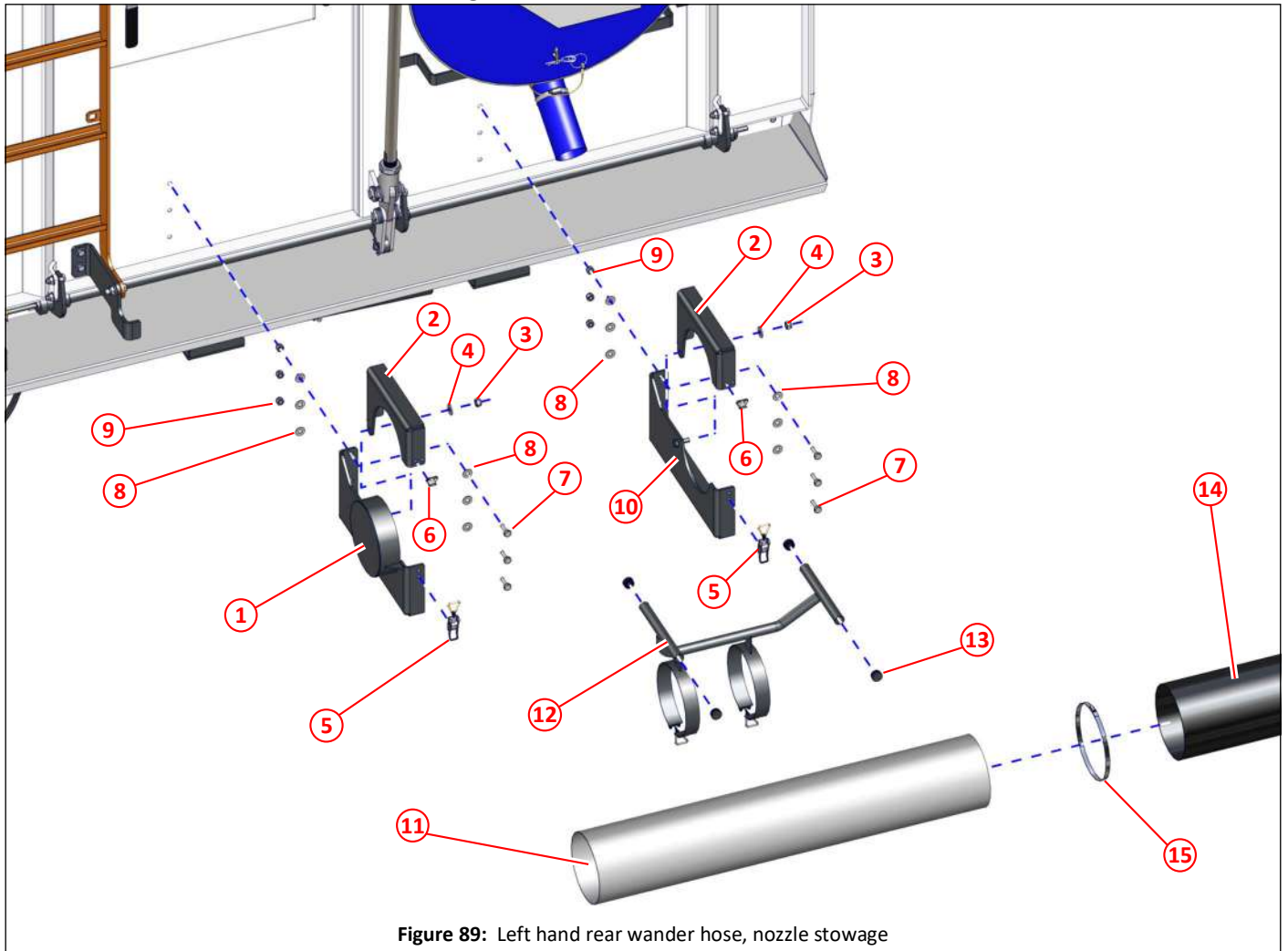

Figure 89: Left hand rear wander hose, nozzle stowage

Item	Part No	Qty	Description	
①	039281	1	Stowage cup, rear wander boom tube, left hand	
②	035962	2	Lock, rear wander boom tube	
③	011077	2	Nyloc nut M12	
④	011096	2	Plain washer M12	
⑤	010509	2	Toggle fastener	
⑥	021841	2	Hook, toggle fastener	
⑦	011032	6	Set screw M10 x 30	
⑧	011094	12	Plain washer M10	
⑨	011075	6	Nyloc nut M10	
⑩	035963	1	Mounting cup, rear wander boom tube	
⑪	035959	1	Tube, rear wander boom	
⑫	039283	1	Handle, rear wander boom	
⑬	026173	4	Plug, plastic $\varnothing$ 25.4, black	
⑭	036062	3m	Wander hose $\varnothing$ 180	115
⑮	012932	1	Hose clamp, worm drive, No. 8.50 ( $\varnothing$ 184mm- $\varnothing$ 216mm)	



Right hand rear wander hose arrangement

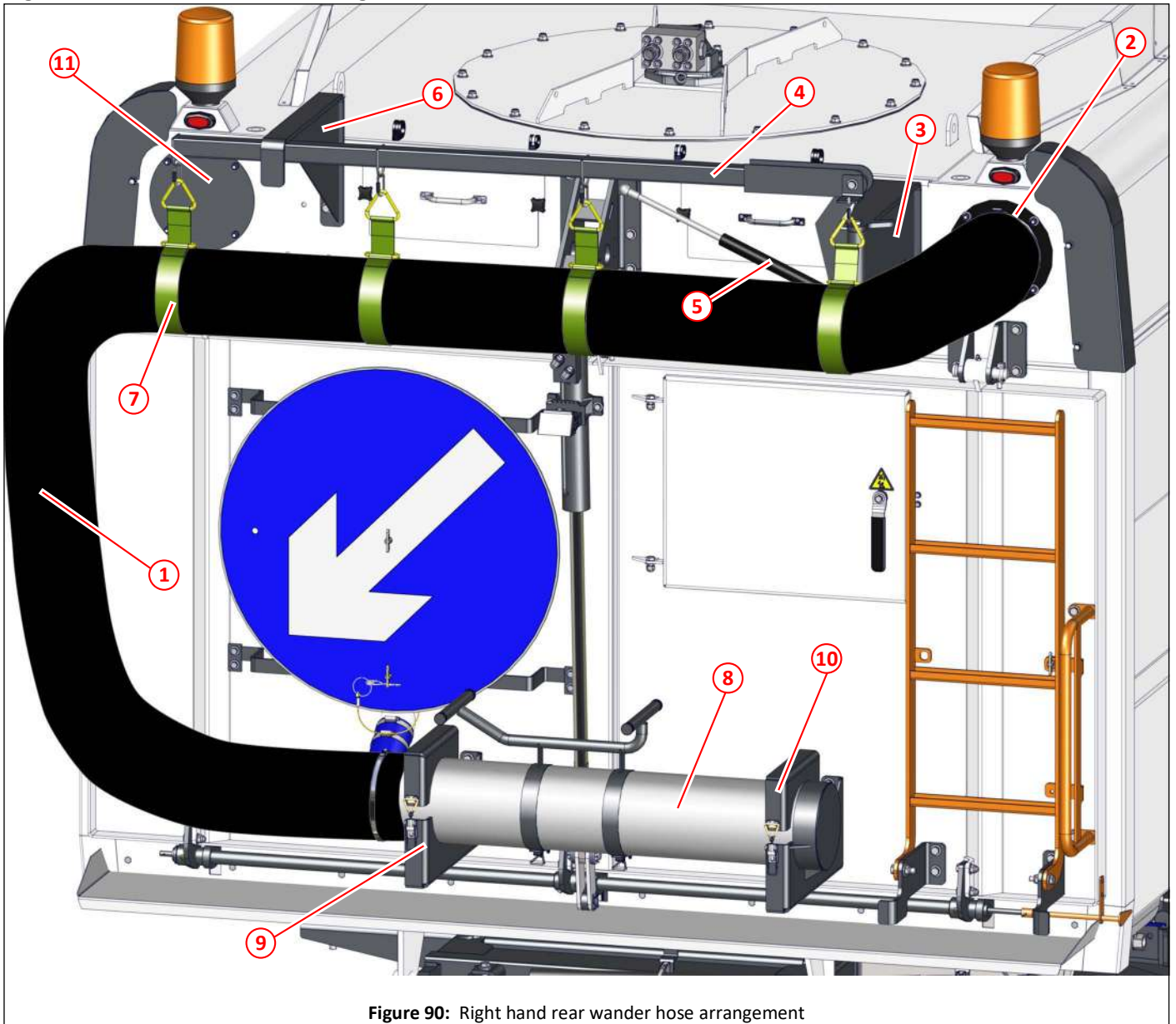

Figure 90: Right hand rear wander hose arrangement

Item	Part No	Qty	Description	
①	036062	3m	Wander hose $\varnothing$ 180	119
②	025225	1	Spigot sleeve, wander hose	120
③	034767	1	Boom hinge, right hand	121
④	0252218	1	Boom, support, wander hose	121
⑤	021993	1	Gas strut	121
⑥	034313	1	Stowage hook, wander boom	121
⑦	025235	4	Straps, wander hose	121
⑧	035959	1	Tube, wander hose	122
⑨		1	Stowage bracket, wander hose tube	122
⑩		1	Stowage cup, wander hose tube	122
⑪	025486	1	Cover, wander hose duct	159

Right hand rear wander hose, spigot sleeve

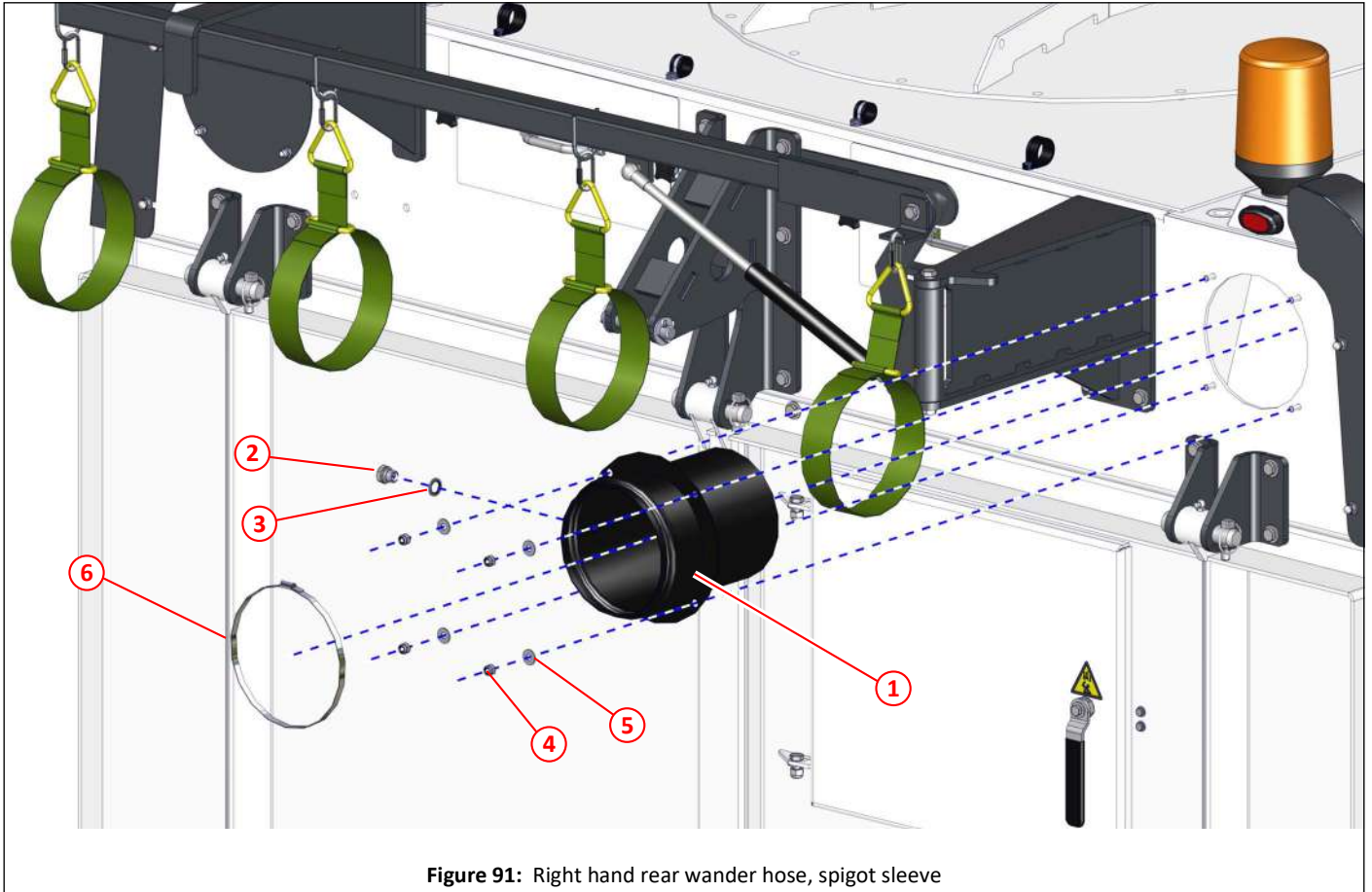

Figure 91: Right hand rear wander hose, spigot sleeve

Item	Part No	Qty	Description	
①	025225	1	Spigot sleeve, rear wander hose	119
②	011242	1	Plug $\frac{3}{8}$ " BSP	
③	011153	1	Dowty seal $\frac{3}{8}$ " BSP	
④	000263	4	Nyloc nut M8, stainless steel	
⑤	000264	4	Plain washer M8, stainless steel	
⑥	012932	1	Hose clamp, worm drive, No. 8.50 ( $\phi$ 184mm- $\phi$ 216mm)	



Right hand rear wander hose, boom

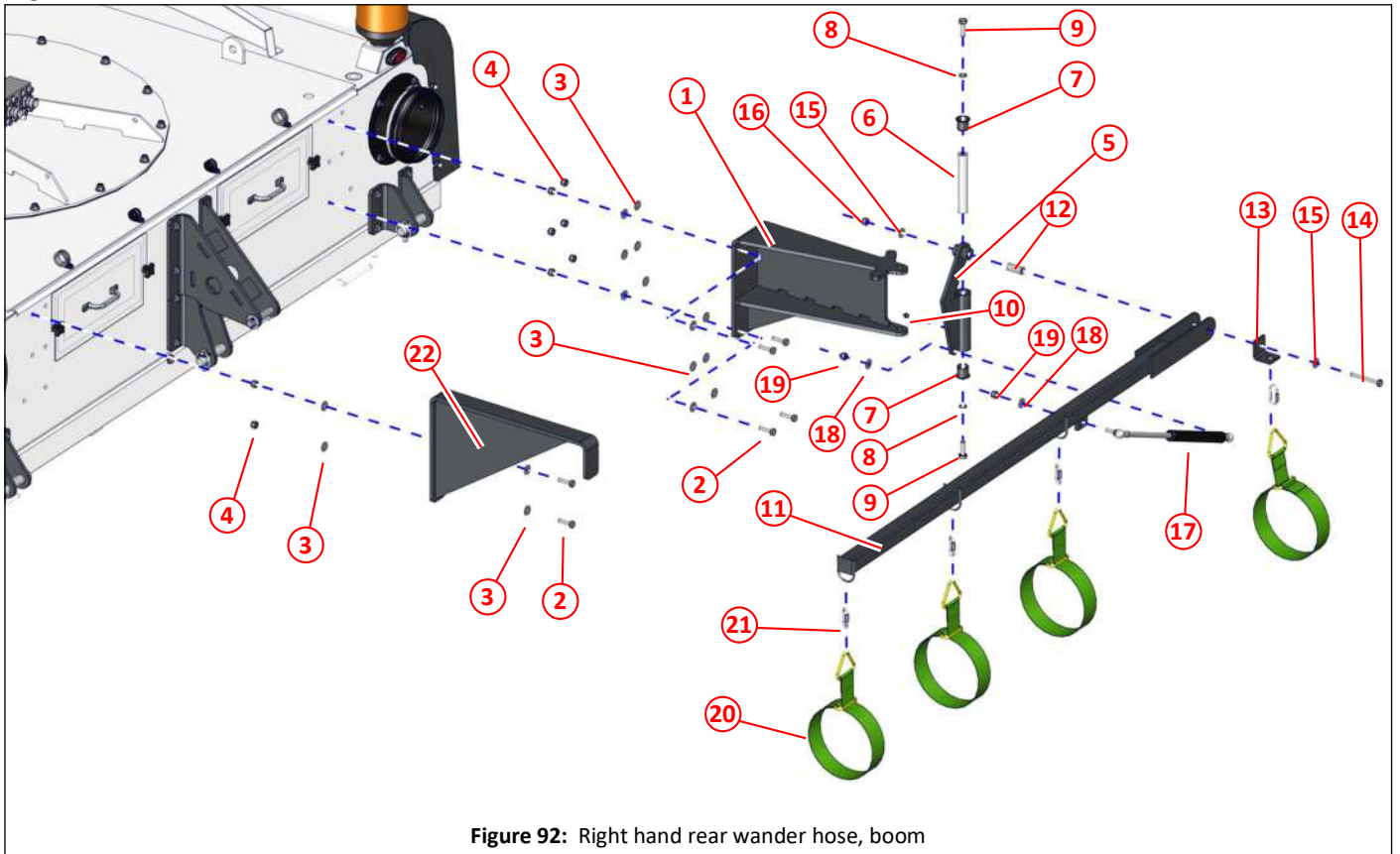

Figure 92: Right hand rear wander hose, boom

Item	Part No	Qty	Description
①	034767	1	Bracket, wander hose boom hinge, right hand
②	011033	8	Set screw M10 x 35
③	011094	16	Plain washer M10
④	011075	8	Nyloc nut M10
⑤	025219	1	Hinge, wander hose boom
⑥	023490	1	Shaft, wander hose boom hinge
⑦	013662	2	Bush
⑧	011097	2	Spring washer M12
⑨	011053	2	Set screw M12 x 35
⑩	010903	1	Grease nipple 1/8" BSP, straight
⑪	025218	1	Boom, support wander hose
⑫	014399	1	Spacer, sleeve ø10.5 x ø20 x 41
⑬	012548	1	Bracket, angle
⑭	011038	1	Bolt M10 x 80
⑮	011094	2	Plain washer M10
⑯	011075	1	Nyloc nut M10
⑰	021993	1	Gas strut
⑱	011094	2	Plain washer M10
⑲	011075	2	Nyloc nut M10
⑳	025235	4	Strap, wander hose
㉑	010606	4	Carabiner
㉒	034313	1	Hook, boom stowage

Right hand rear wander hose, nozzle storage

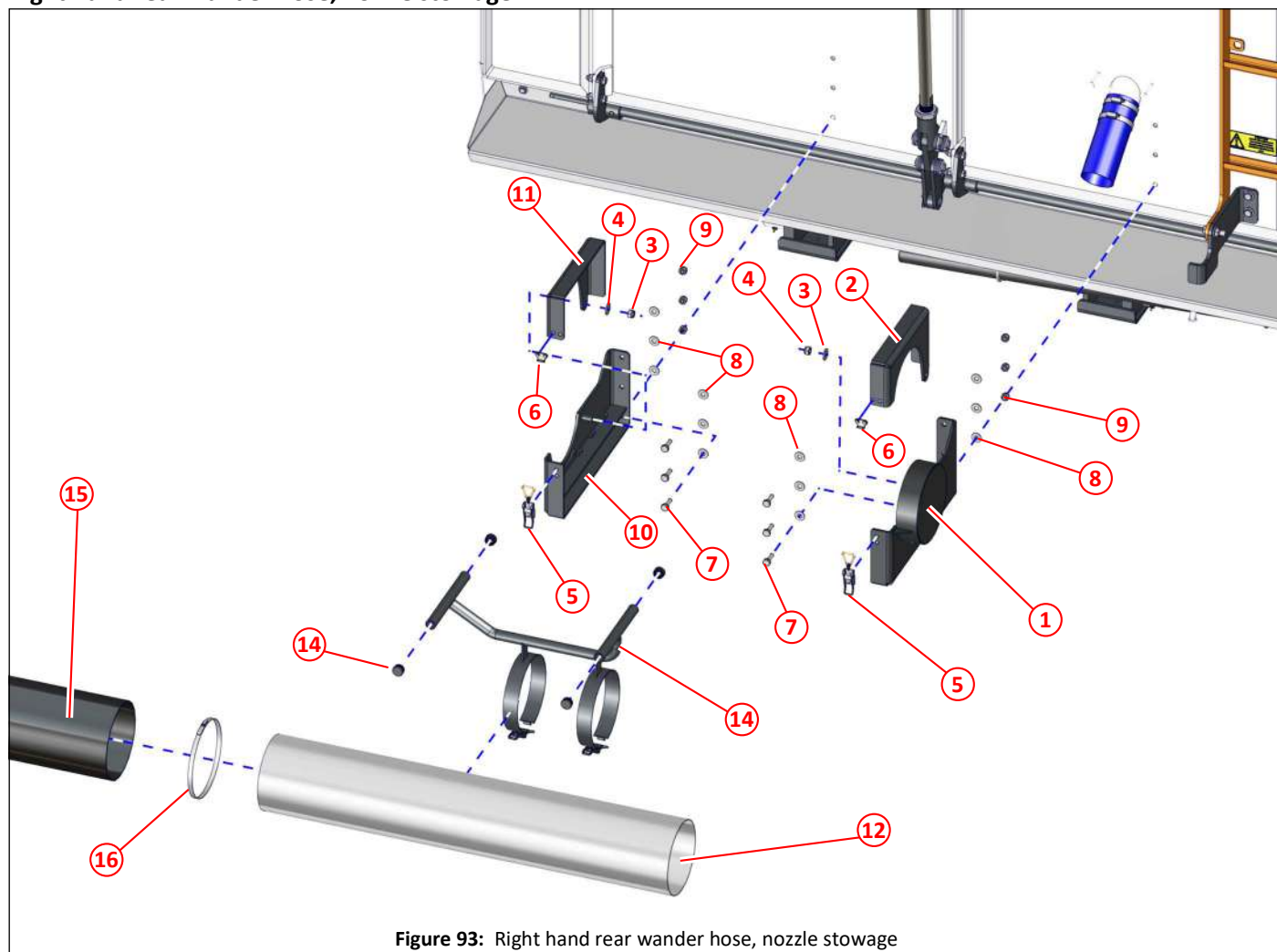

Figure 93: Right hand rear wander hose, nozzle storage

Item	Part No	Qty	Description	
①	039280	1	Stowage cup, rear wander boom tube, right hand	
②	039282	1	Lock, rear wander boom tube	
③	011077	2	Nyloc nut M12	
④	011096	2	Plain washer M12	
⑤	010509	2	Toggle fastener	
⑥	021841	2	Hook, toggle fastener	
⑦	011032	6	Set screw M10 x 30	
⑧	011094	12	Plain washer M10	
⑨	011075	6	Nyloc nut M10	
⑩	035963	1	Mounting cup, rear wander boom tube	
⑪	035962	1	Lock, rear wander boom tube	
⑫	035959	1	Tube, rear wander boom	119
⑬	039283	1	Handle, rear wander boom	
⑭	026173	4	Plug, plastic ø25.4, black	
⑮	036062	3m	Wander hose ø180	119
⑯	012932	1	Hose clamp, worm drive, No. 8.50 (ø184mm-ø216mm)	

Left hand overhead boom suction nozzle arrangement

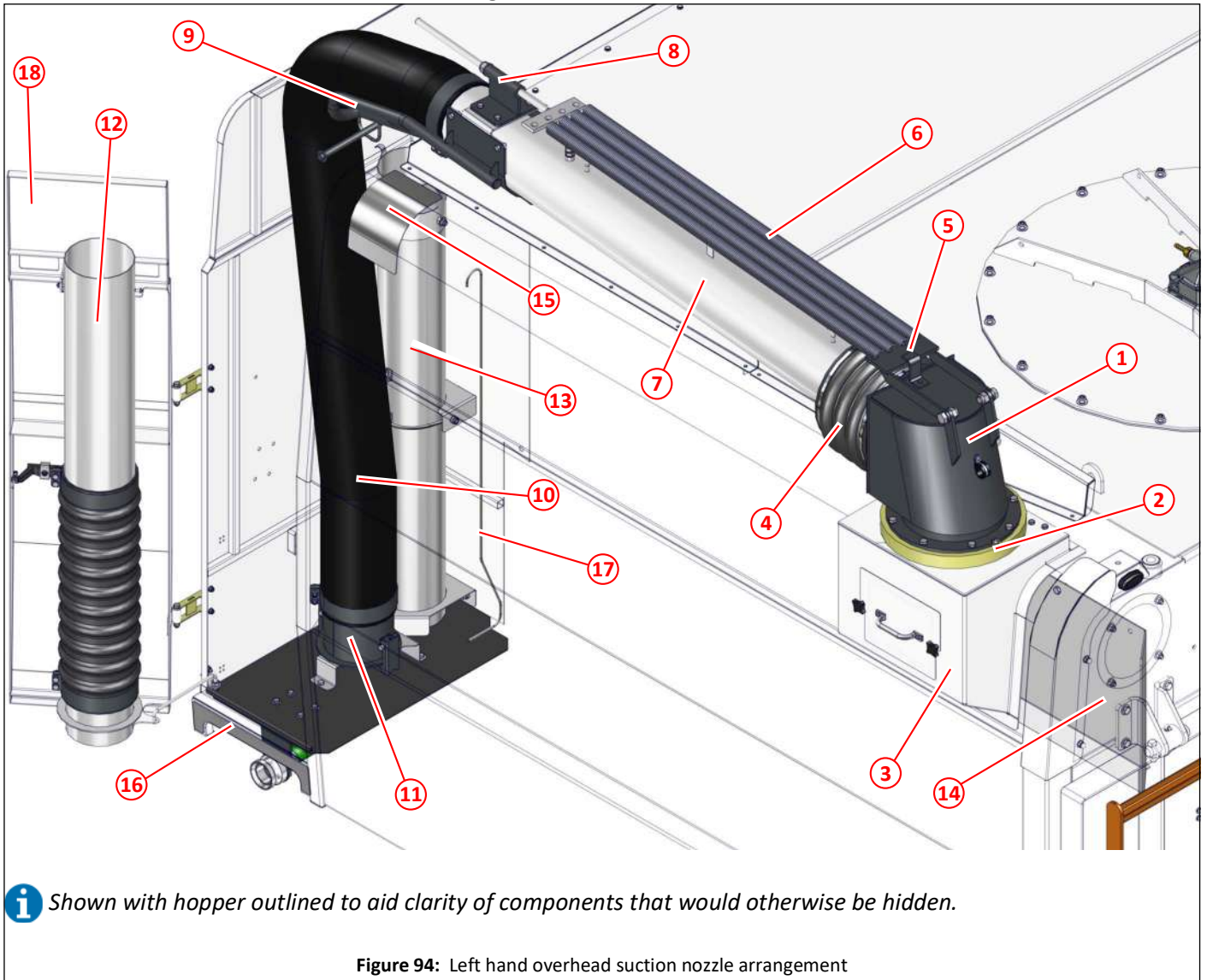

Figure 94: Left hand overhead suction nozzle arrangement

Item	Part No	Qty	Description	
①	013793	1	Elbow, overhead boom	124,125,126
②			Ring, bearing, assembly	124,125,126
③	044737	1	Over head boom carrier. This is a welded on item.	124,125,126
④	044107	1	Cuff, overhead boom pivot	126,127
⑤	013801	1	Bracket, spring anchor	126
⑥	013805	4	Spring	126,127
⑦	044120	1	Suction pipe, overhead boom	126,127,128
⑧	044126	1	Bracket, spring tensioner	127
⑨	044122	1	Cradle, overhead boom	128
⑩	044105	2m	Hose, overhead boom	128
⑪	044124	1	Coupling, hose, overhead boom	128
⑫	044139	1	Extension, flexible, overhead boom	139
⑬	044155	1	Extension, overhead boom	139
⑭	044147	1	Deflector, overhead boom, inside hopper, left hand	124
⑮	044384	1	Plate, hopper protector, overhead boom	129
⑯	044383	1	Plate, locker protector, overhead boom	129
⑰	044753	1	Hook, overhead boom	
⑱			Locker components, overhead boom, left hand	129,130

Left hand overhead boom carrier inspection hatch and deflector

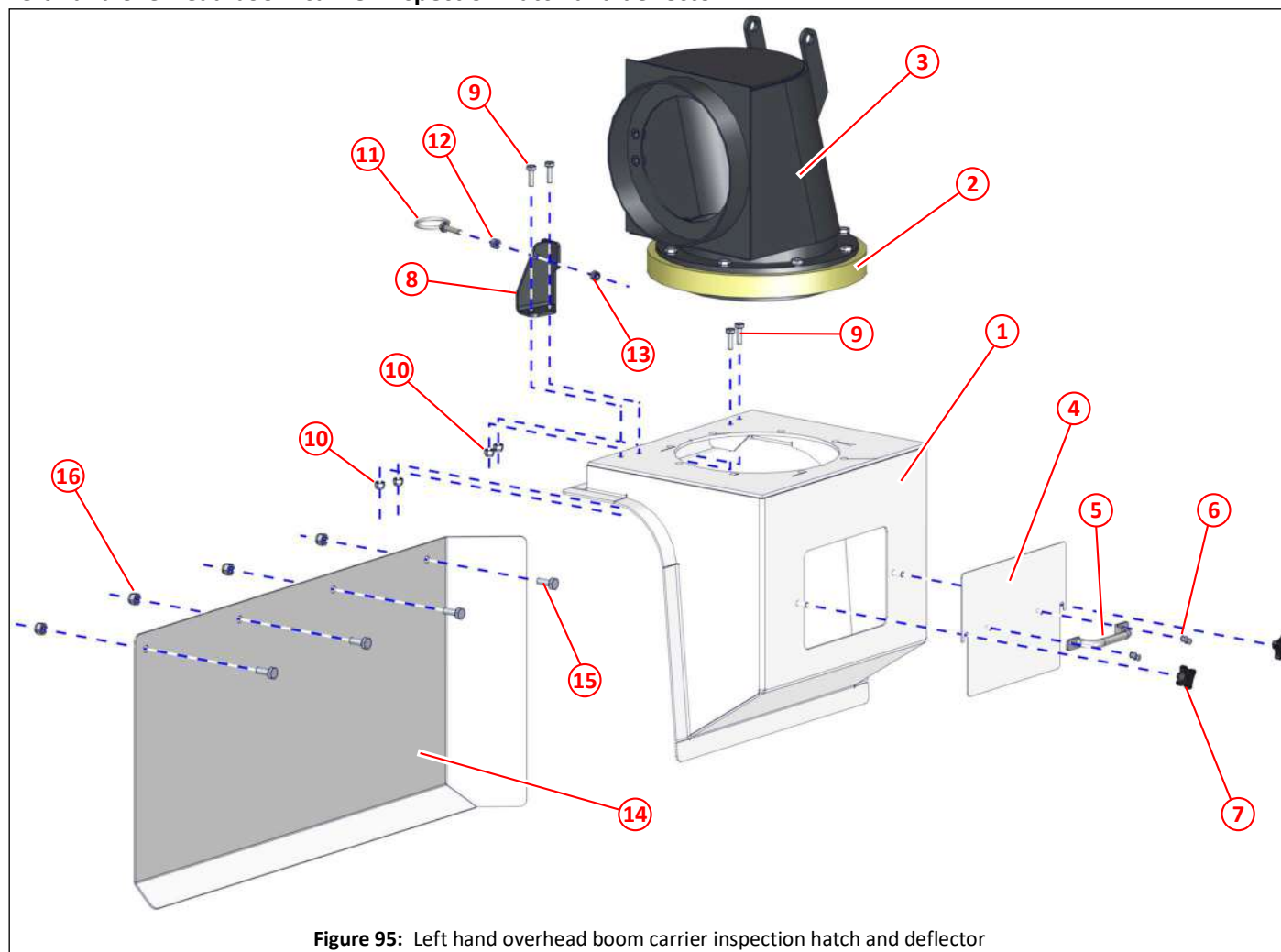

Figure 95: Left hand overhead boom carrier inspection hatch and deflector

Item	Part No	Qty	Description	
①	044737	1	Over head boom carrier. This is a welded on item.	123,125,126
②			Ring, bearing, assembly	123,125,126
③	013793	1	Elbow, overhead boom	123,125,126
④	032351	1	Access cover, overhead boom carrier	
⑤	010502	1	Handle	
⑥	011131	4	Rivet, blind $\phi 4.8 \times 18$	
⑦	000248	2	Grip nut	
⑧	044755	1	Boom stop	
⑨	000257	4	Set screw M8 x 25, stainless steel	
⑩	000263	4	Nyloc nut M8, stainless steel	
⑪	033022	1	Ring, hose guide	
⑫	000262	1	Full nut M8, stainless steel	
⑬	011073	1	Nyloc nut M8	
⑭	044147	1	Deflector, overhead boom, inside hopper, left hand	123
⑮	000280	4	Set screw M10 x 25, stainless steel	
⑯	000269	4	Nyloc nut M10, stainless steel	

Left hand overhead boom elbow and bearing

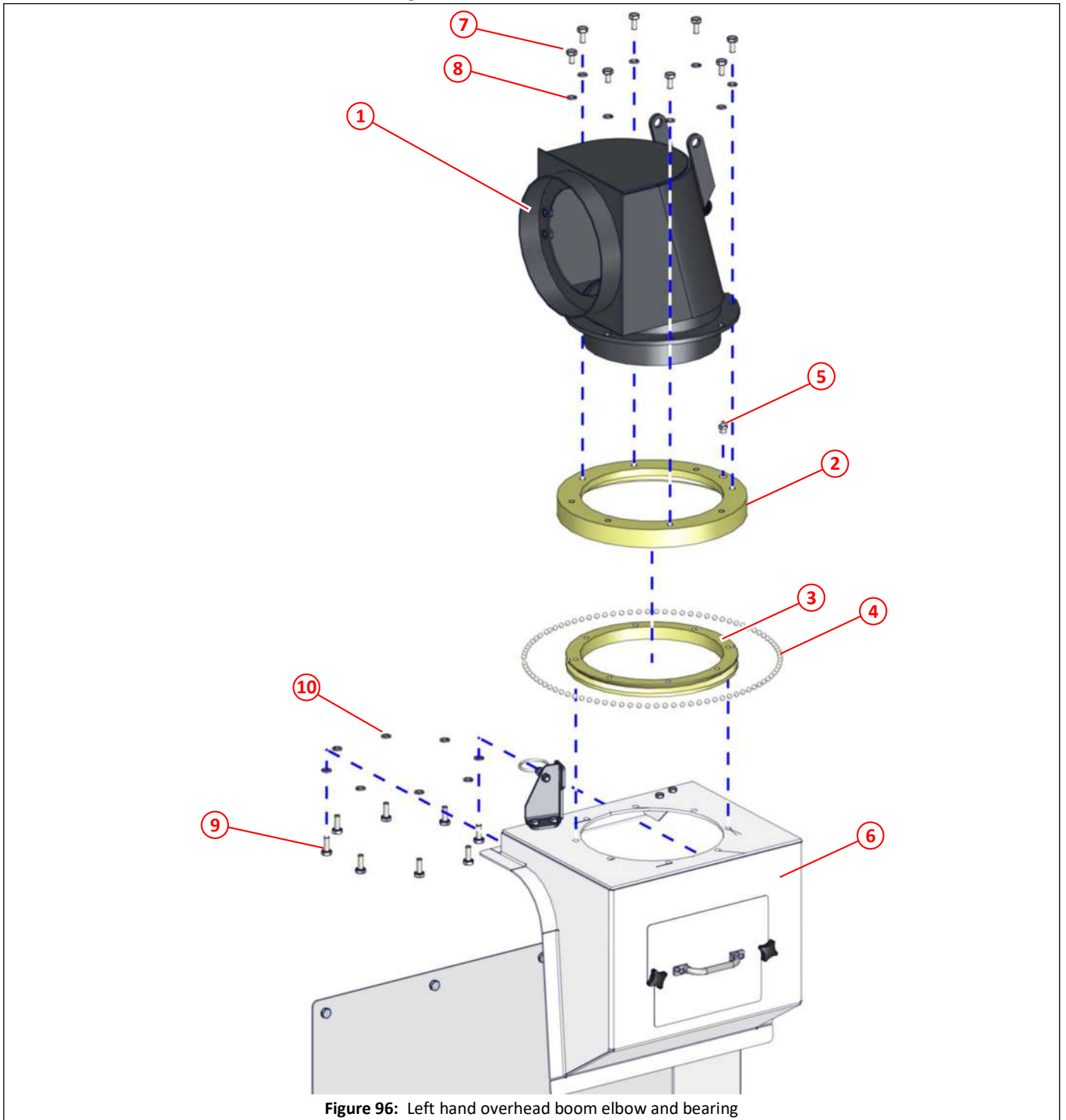

Figure 96: Left hand overhead boom elbow and bearing

Item	Part No	Qty	Description	
①	013793	1	Elbow, overhead boom	123,124,126
②	013788	1	Ring, bearing, outer	
③	013789	1	Ring, bearing, inner	
④	013791	91	Ball, steel, $\varnothing 10$	
⑤	013792	1	Grease nipple $\frac{1}{4}$ " BSP	
⑥	044737	1	Overhead boom carrier. This is a welded on item.	123,124,126
⑦	011030	8	Set screw M10 x 20	
⑧	011095	8	Spring washer M10	
⑨	011031	8	Set screw M10 x 25	
⑩	011095	8	Spring washer M10	



Left hand overhead boom suction tube, pivot and cuff

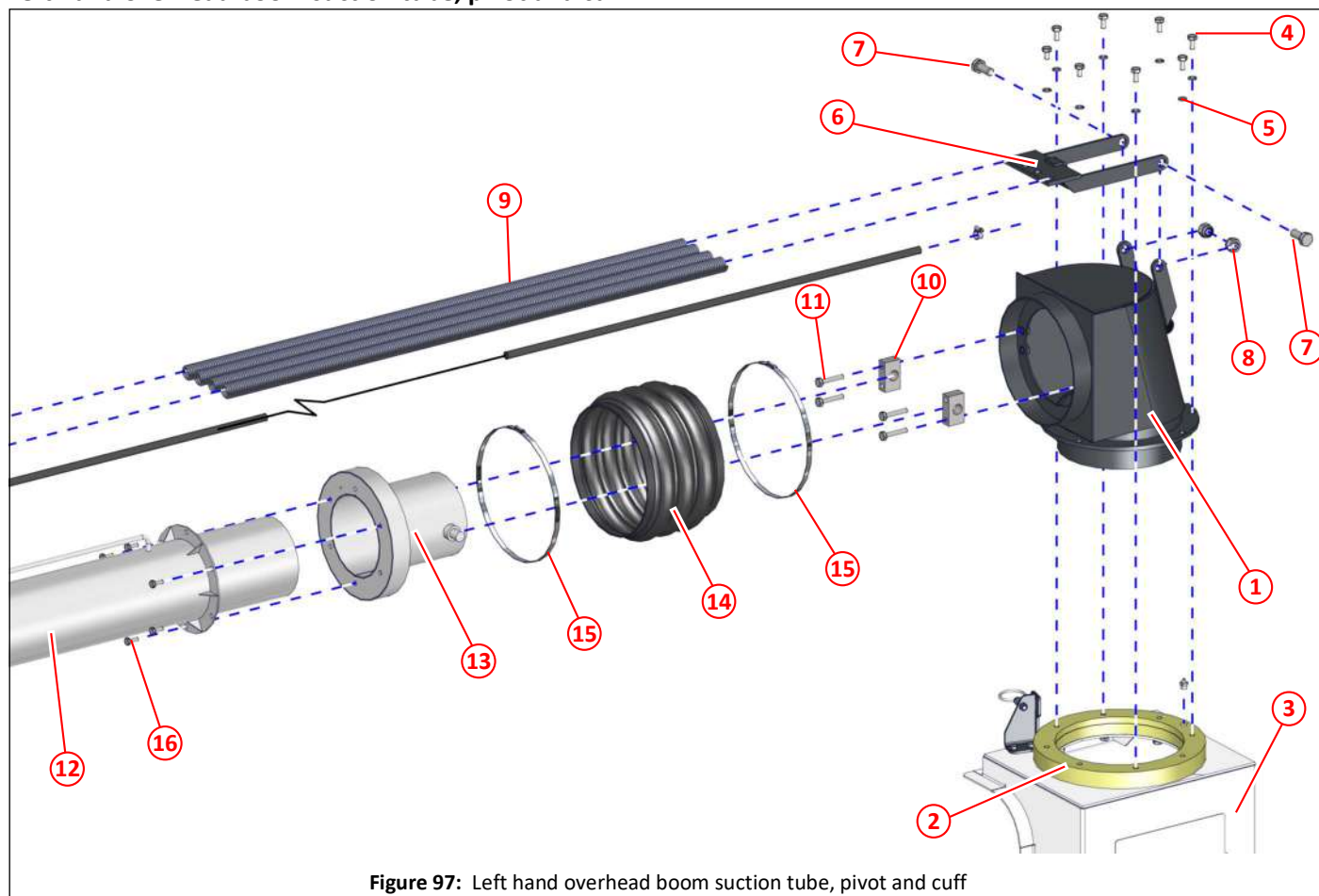

Figure 97: Left hand overhead boom suction tube, pivot and cuff

Item	Part No	Qty	Description	
①	013793	1	Elbow, overhead boom	123,124,125
②			Ring, bearing assembly	123,124,125
③	044737	1	Over head boom carrier. This is a welded on item.	123,124,125
④	011030	8	Set screw M10 x 20	
⑤	011095	8	Spring washer M10	
⑥	013801	1	Bracket, spring anchor	123
⑦	011141	2	Bolt M16 x 35	
⑧	011060	2	Nyloc nut M16	
⑨	013805	4	Spring 800	123
⑩	013798	2	Pivot block	
⑪	011035	4	Set screw M10 x 50	
⑫	044120	1	Pipe, suction, overhead boom	123,127,128
⑬	044121	1	Pivot, overhead boom	127
⑭	044107	1	Cuff, overhead boom pivot	123,127
⑮	012933	2	Hose clamp, worm drive, No. 10.50 (ø235mm-ø267mm)	
⑯	011010	6	Set screw M8 x 20	



Left hand overhead boom suction tube, springs

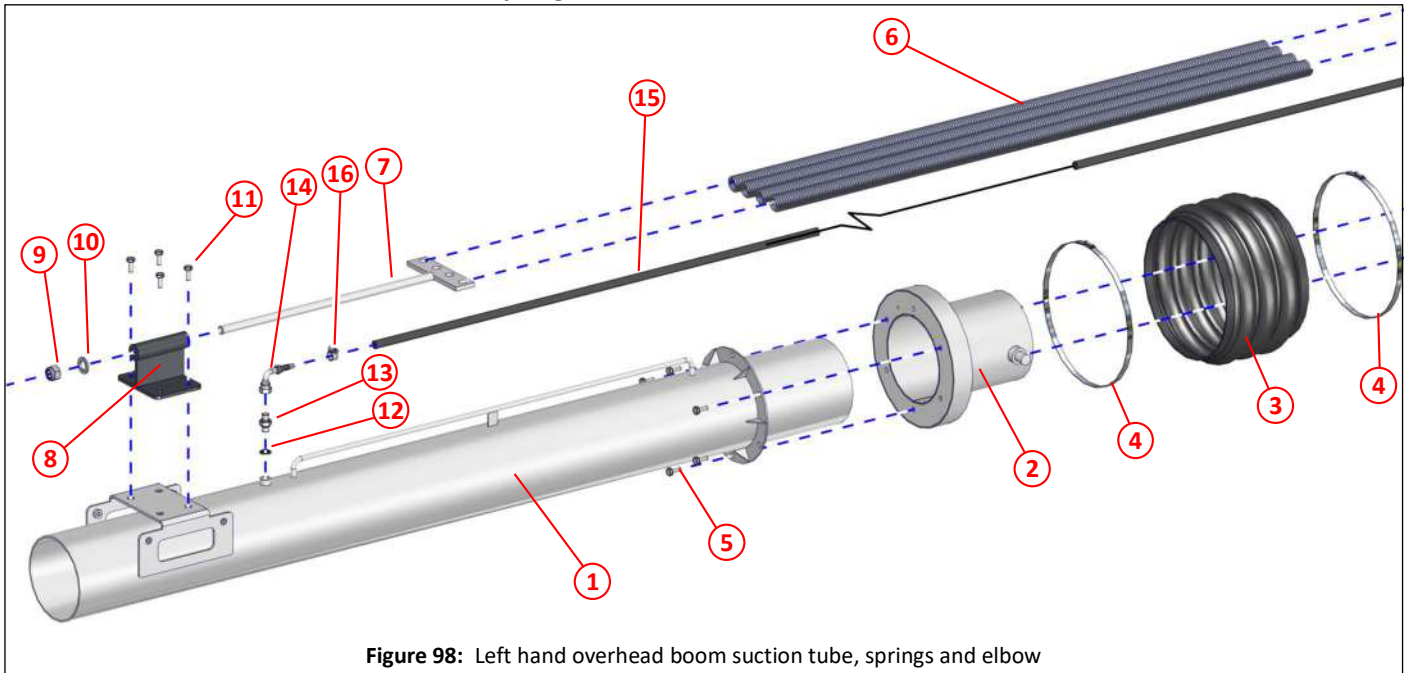

Figure 98: Left hand overhead boom suction tube, springs and elbow

Item	Part No	Qty	Description	
①	044120	1	Pipe, suction, overhead boom	123,126,128
②	044121	1	Pivot, overhead boom	126
③	044107	1	Cuff, overhead boom pivot	123,126
④	012933	2	Hose clamp, worm drive, No. 10.50 (ø235mm-ø267mm)	
⑤	011010	6	Set screw M8 x 20	
⑥	013805	4	Spring 800	123,126
⑦	013804	1	Tensioner, overhead boom	
⑧	044126	1	Bracket, spring tensioner	123
⑨	011060	1	Nyloc nut M16	
⑩	011135	1	Plain washer M16	
⑪	011010	4	Set screw M8 x 20	
⑫	011152	1	Dowty seal 1/4" BSP	
⑬	011158	1	Adapter 1/4" BSP	
⑭	002237	1	Adapter 1/4" BSPF x 3/8" hose tail, 90°	
⑮	010950	As req	Hose ø9.5 ID, black braided PVC	
⑯	010516	2	Hose clamp, worm drive, No. M00 (ø11mm-ø16mm)	

Left hand overhead boom suction hose and cradle

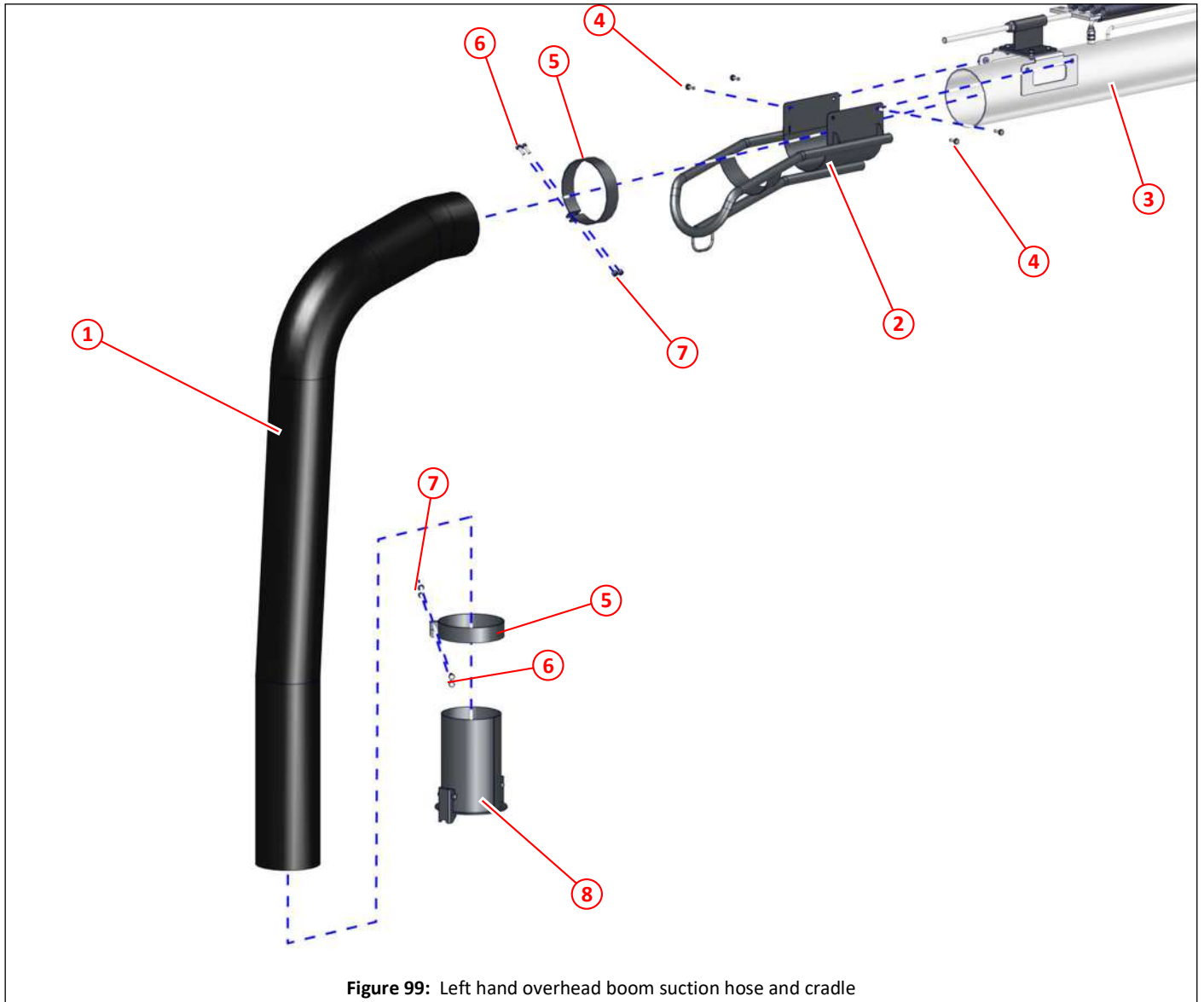

Figure 99: Left hand overhead boom suction hose and cradle

Item	Part No	Qty	Description	
①	044105	2m	Hose, overhead boom	123
②	044122	1	Cradle, overhead boom	123
③	044120	1	Pipe, suction, overhead boom	123,126,127
④	011010	4	Set screw M8 x 20	
⑤	044376	2	Clamp, hose, overhead boom	
⑥	000257	4	Set screw M8 x 25, stainless steel	
⑦	000263	4	Nyloc nut M8, stainless steel	
⑧	044124	1	Hose, coupling, overhead boom	123

Left hand overhead boom locker door components

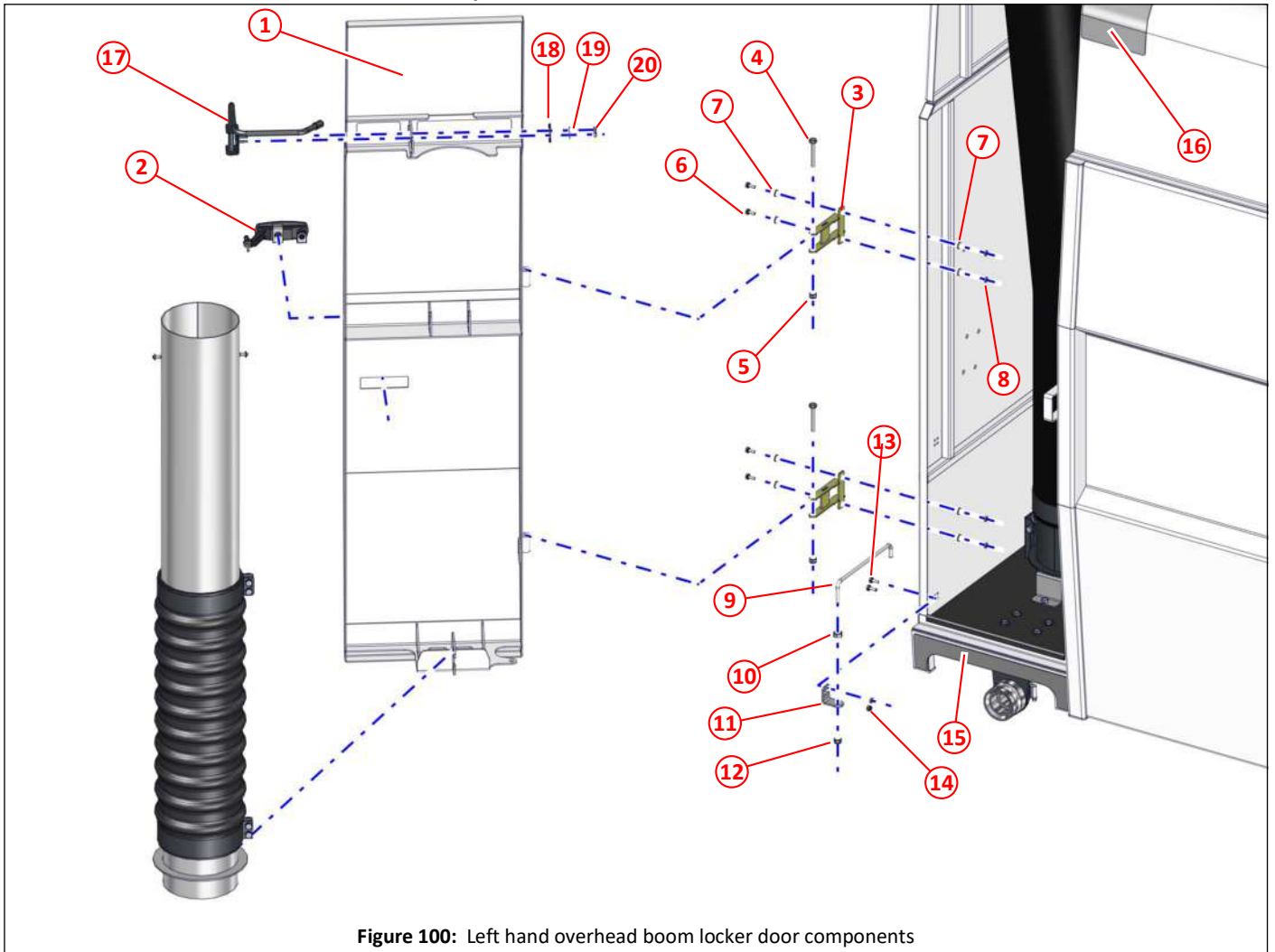
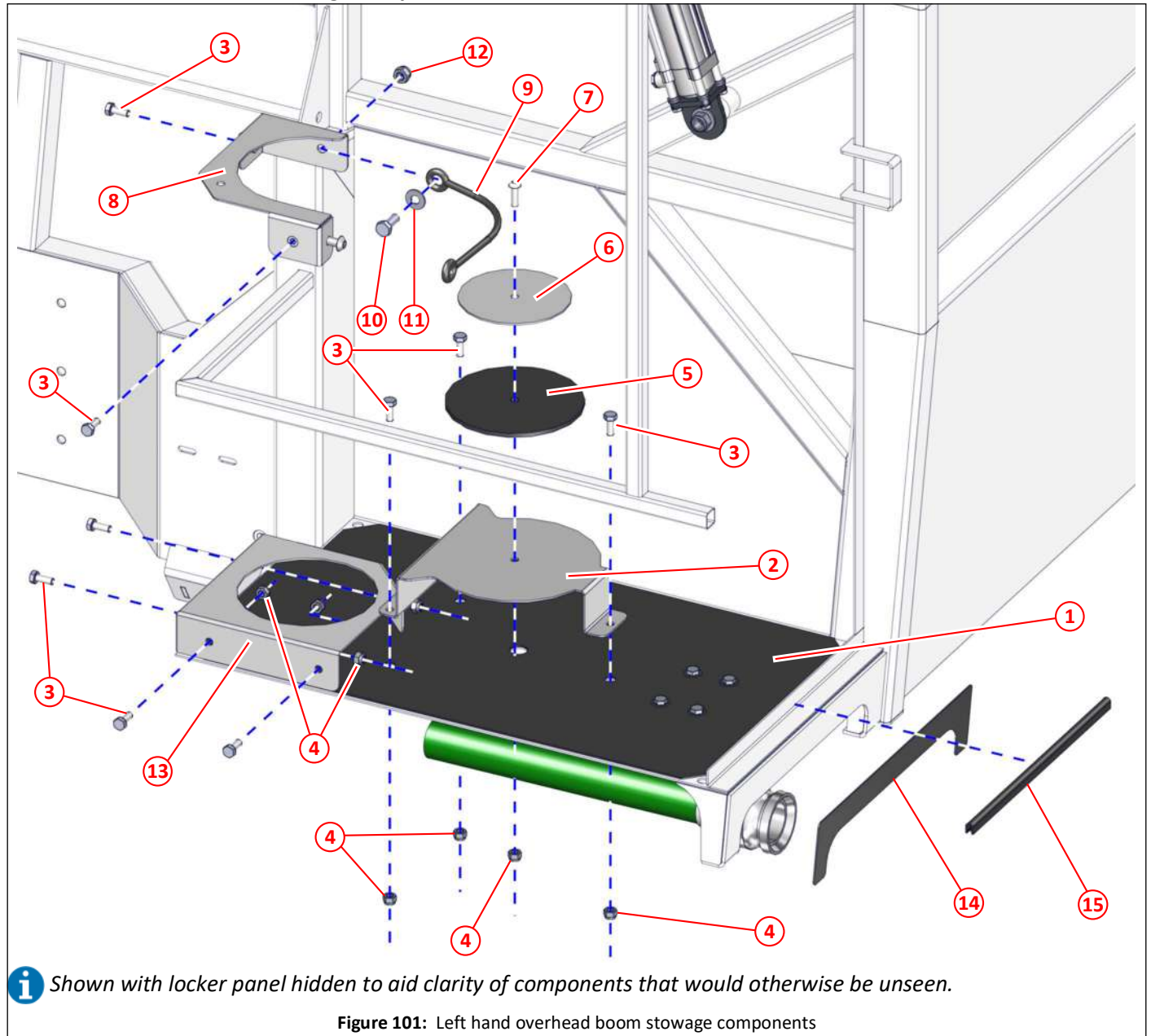

Figure 100: Left hand overhead boom locker door components

Item	Part No	Qty	Description	
①	044146	1	Door, locker, overhead boom, left hand	123
②	033115	1	Latch, locking	
③	044144	2	Hinge, locker door, overhead boom	
④	000261	2	Set screw M8 x 55, stainless steel	
⑤	000263	2	Nyloc nut M8, stainless steel	
⑥	000250	4	Set screw M6 x 16, stainless steel	
⑦	000254	4	Plain washer M6, stainless steel	
⑧	000253	4	Nyloc nut M6, stainless steel	
⑨	044407	1	Door stay, overhead boom	
⑩	011074	1	Full nut M10	
⑪	044408	1	Bracket, door stay, overhead boom	
⑫	000263	1	Nyloc nut M8, stainless steel	
⑬	011001	2	Set screw M6 x 16	
⑭	011071	2	Nyloc nut M6	
⑮	044383	1	Plate, locker protector, overhead boom	123,130
⑯	044384	1	Plate, hopper protector, overhead boom	123
⑰	045504	1	Hose protector left hand side	
⑱	027989	1	Plate, backing brace	
⑲	000254	2	Plain washer M6, stainless steel	
⑳	000253	2	Nyloc nut M6, stainless steel	

Left hand overhead boom stowage components



**i** Shown with locker panel hidden to aid clarity of components that would otherwise be unseen.

Figure 101: Left hand overhead boom stowage components

Item	Part No	Qty	Description	
①	044150	1	Rubber mat	
②	044127	1	Bracket, hose coupling stowage	
③	000256	9	Set screw M8 x 20, stainless steel	
④	000263	8	Nyloc nut M8, stainless steel	
⑤	044129	1	Sealing disc, rubber	
⑥	044130	1	Sealing plate	
⑦	000281	1	Socket button head screw, M8 x 25, stainless steel	
⑧	044752	1	Bracket, upper, extension stowage	
⑨	044007	1	Mini-tie No. 10	
⑩	000280	1	Set screw M10 x 25, stainless steel	
⑪	000270	1	Plain washer M10, stainless steel	
⑫	000269	1	Nyloc nut m10, stainless steel	
⑬	044149	1	Bracket, bottom, extension stowage	
⑭	044383	1	Plate, locker protector, overhead boom	123,129
⑮	010545	345mm	Titanfast, edging strip	

Right hand overhead boom suction nozzle arrangement

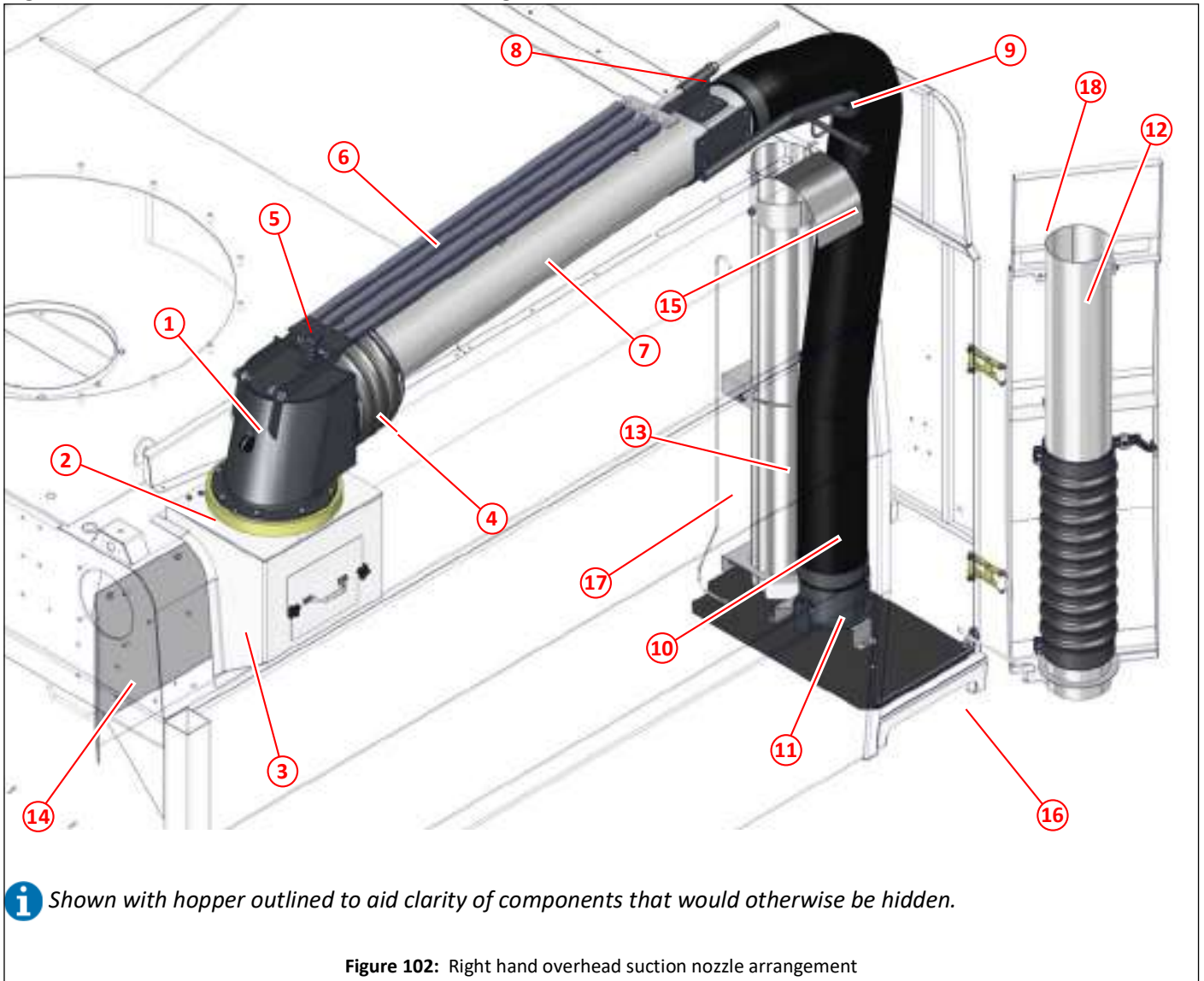

**i** Shown with hopper outlined to aid clarity of components that would otherwise be hidden.

Figure 102: Right hand overhead suction nozzle arrangement

Item	Part No	Qty	Description	
①	013793	1	Elbow, overhead boom	132,133,134
②			Ring, bearing, assembly	132,133,134
③	044737	1	Over head boom carrier. This is a welded on item.	132,133,134
④	044107	1	Cuff, overhead boom pivot	134,135
⑤	013801	1	Bracket, spring retainer	134
⑥	013805	4	Spring	134,135
⑦	044120	1	Suction pipe, overhead boom	134,135,136
⑧	044126	1	Bracket, spring tensioner	135
⑨	044122	1	Cradle, overhead boom	136
⑩	044105	2m	Hose, overhead boom	136
⑪	044124	1	Coupling, hose, overhead boom	136
⑫	044139	1	Extension, flexible, overhead boom	139
⑬	044155	1	Extension, overhead boom	139
⑭	044756	1	Deflector, overhead boom, inside hopper, right hand	123
⑮	044384	1	Plate, hopper protector, overhead boom	137
⑯	044383	1	Plate, locker protector, overhead boom	137,138
⑰	044753	1	Hook, overhead boom	
⑱			Locker components, overhead boom, right hand	137,138



Right hand overhead boom carrier access cover and deflector

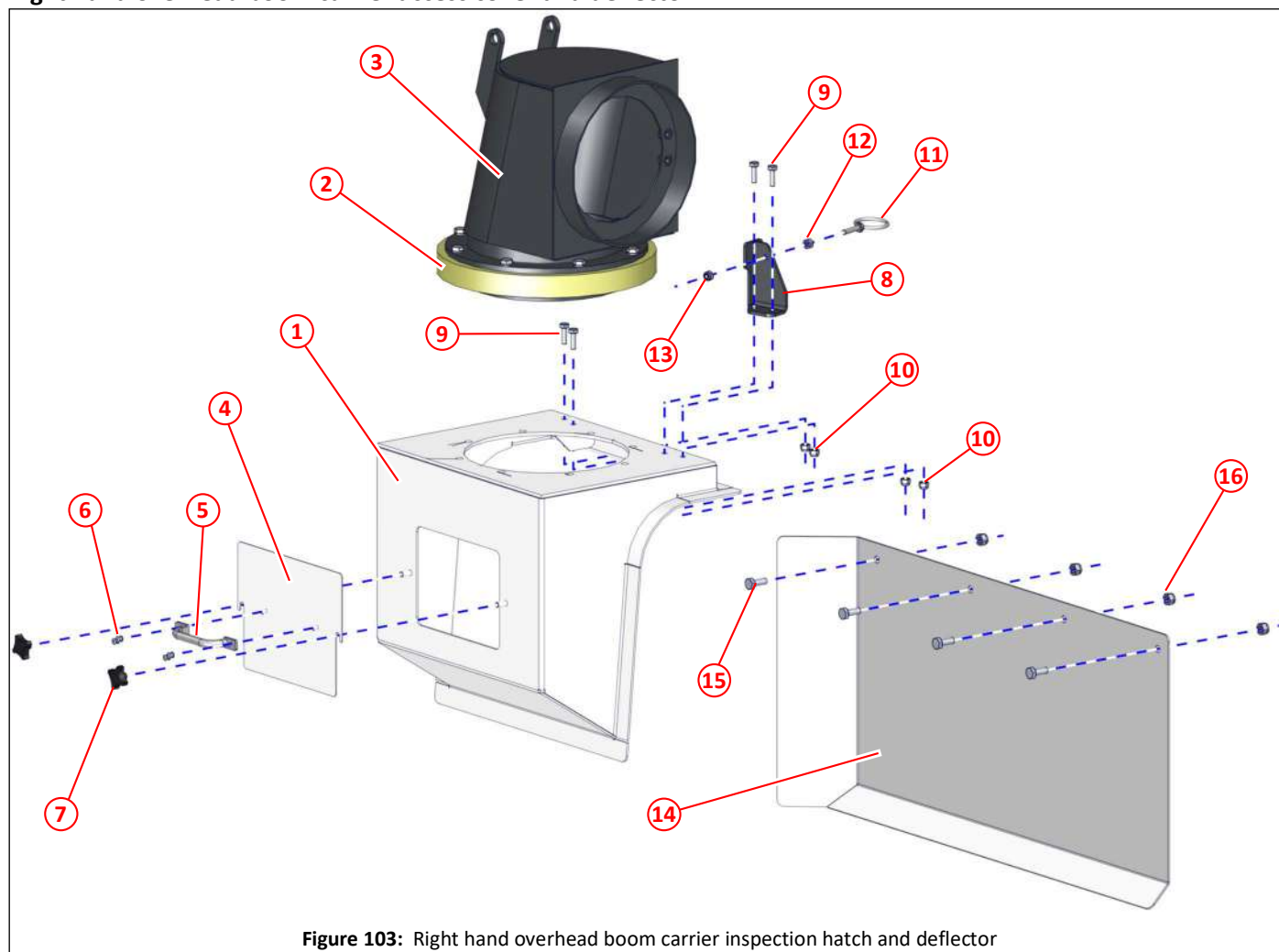

Figure 103: Right hand overhead boom carrier inspection hatch and deflector

Item	Part No	Qty	Description	
①	044737	1	Over head boom carrier. This is a welded on item.	131,133,134
②			Ring, bearing, assembly	131,133,134
③	013793	1	Elbow, overhead boom	131,133,134
④	032351	1	Access cover, overhead boom carrier	
⑤	010502	1	Handle	
⑥	011131	4	Rivet, blind $\phi 4.8 \times 18$	
⑦	000248	2	Grip nut	
⑧	044755	1	Boom stop	
⑨	000257	4	Set screw M8 x 25, stainless steel	
⑩	000263	4	Nyloc nut M8, stainless steel	
⑪	033022	1	Ring, hose guide	
⑫	000262	1	Full nut M8, stainless steel	
⑬	011073	1	Nyloc nut M8	
⑭	044756	1	Deflector, overhead boom, inside hopper, right hand	131
⑮	000280	4	Set screw M10 x 25, stainless steel	
⑯	000269	4	Nyloc nut M10, stainless steel	



Right hand overhead boom elbow and bearing

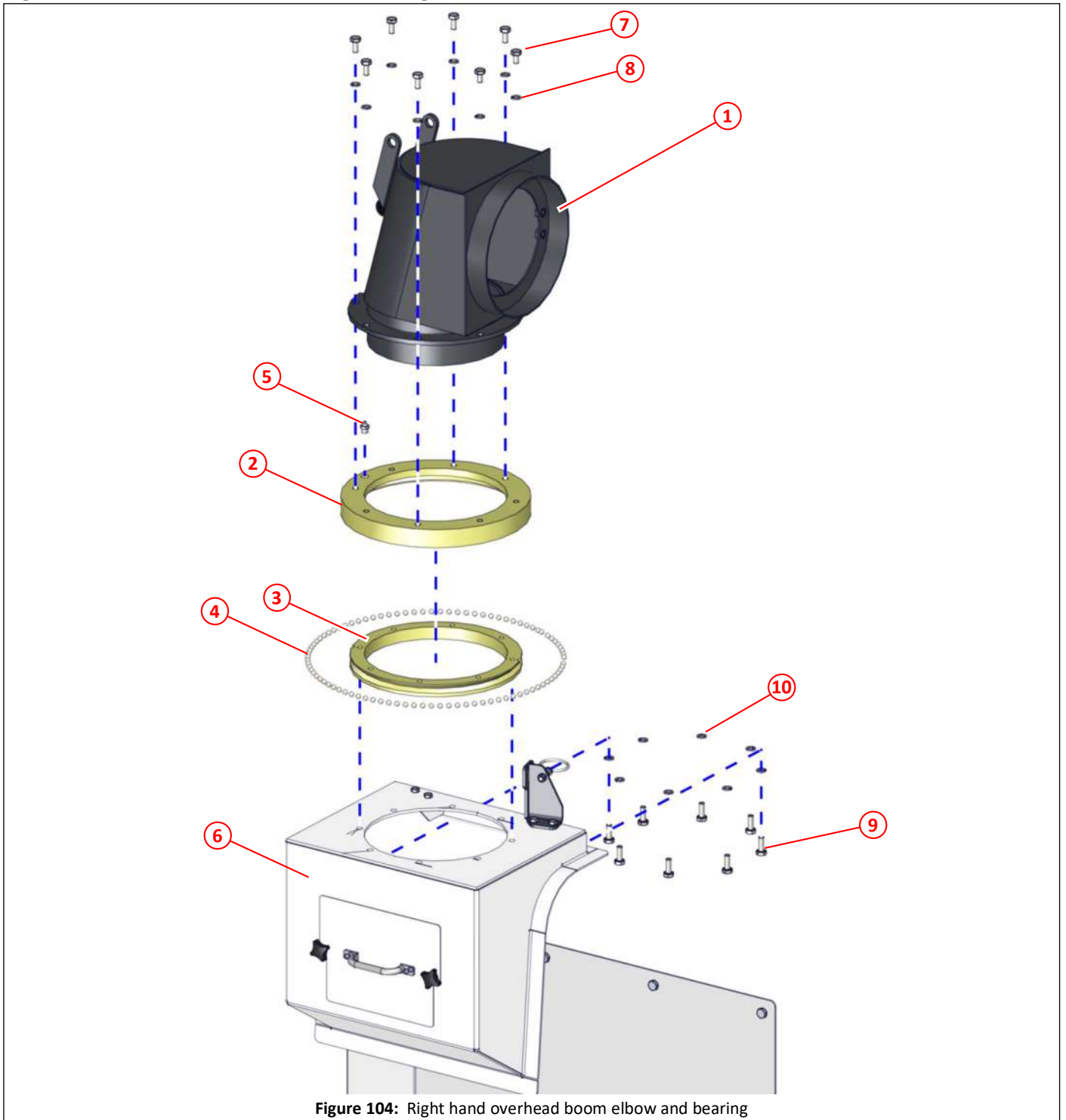

Figure 104: Right hand overhead boom elbow and bearing

Item	Part No	Qty	Description	
①	013793	1	Elbow, overhead boom	131,132,134
②	013788	1	Ring, bearing, outer	
③	013789	1	Ring, bearing, inner	
④	013791	91	Ball, steel, $\varnothing 10$	
⑤	013792	1	Grease nipple $\frac{1}{4}$ " BSP	
⑥	044737	1	Over head boom carrier. This is a welded on item.	131,132,134
⑦	011030	8	Set screw M10 x 20	
⑧	011095	8	Spring washer M10	
⑨	011031	8	Set screw M10 x 25	
⑩	011095	8	Spring washer M10	

Right hand overhead boom suction tube, pivot and cuff

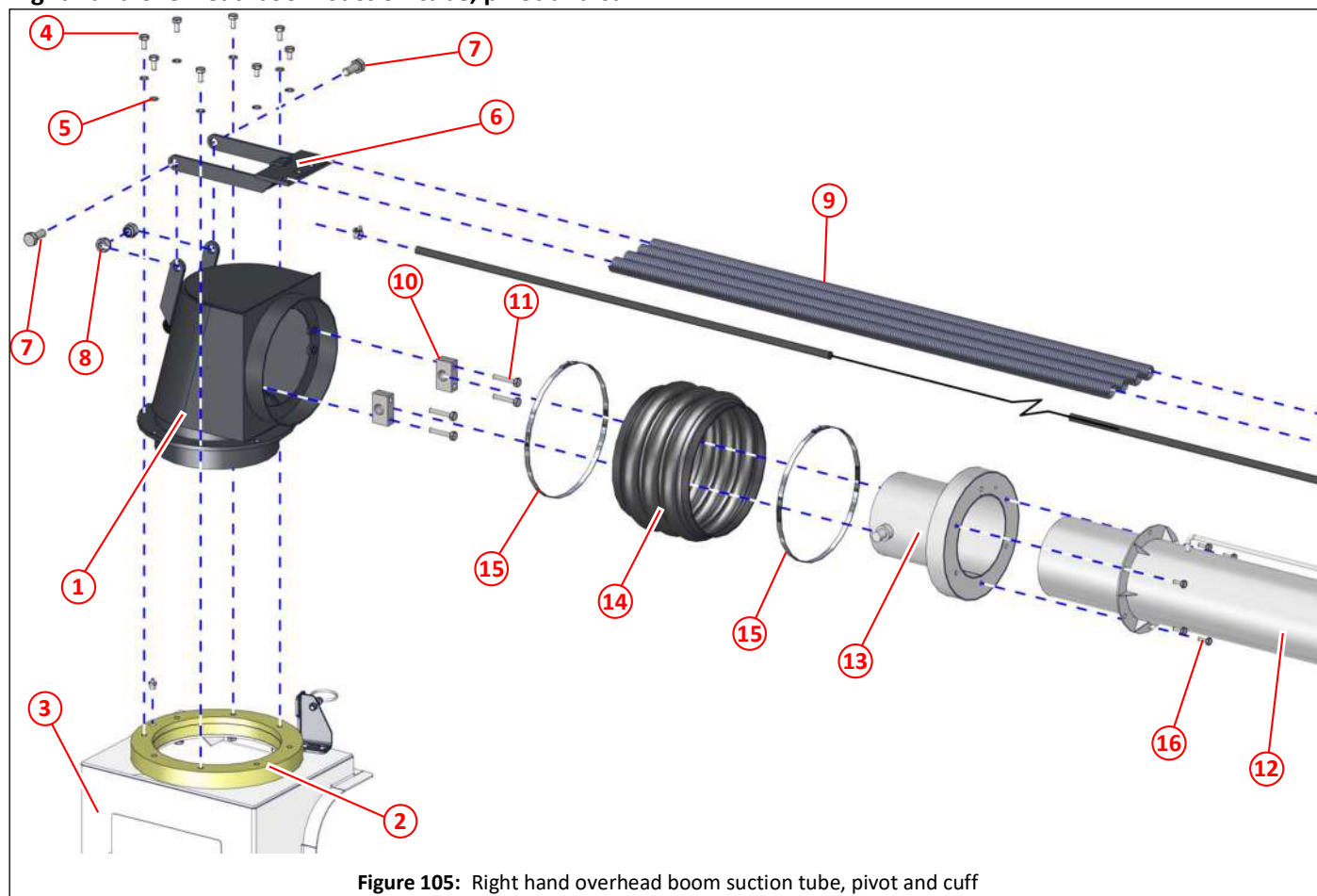

Figure 105: Right hand overhead boom suction tube, pivot and cuff

Item	Part No	Qty	Description	
①	013793	1	Elbow, overhead boom	131,132,133
②			Ring, bearing assembly	131,132,133
③	044737	1	Over head boom carrier. This is a welded on item.	131,132,133
④	011030	8	Set screw M10 x 20	
⑤	011095	8	Spring washer M10	
⑥	013801	1	Bracket, spring anchor	131
⑦	011141	2	Bolt M16 x 35	
⑧	011060	2	Nyloc nut M16	
⑨	013805	4	Spring 800	131,135
⑩	013798	2	Pivot block	
⑪	011035	4	Set screw M10 x 50	
⑫	044120	1	Pipe, suction, overhead boom	131,135,136
⑬	044121	1	Pivot, overhead boom	135
⑭	044107	1	Cuff, overhead boom pivot	131,135
⑮	012933	2	Hose clamp, worm drive, No. 10.50 (ø235mm-ø267mm)	
⑯	011010	6	Set screw M8 x 20	

Right hand overhead boom suction tube, springs

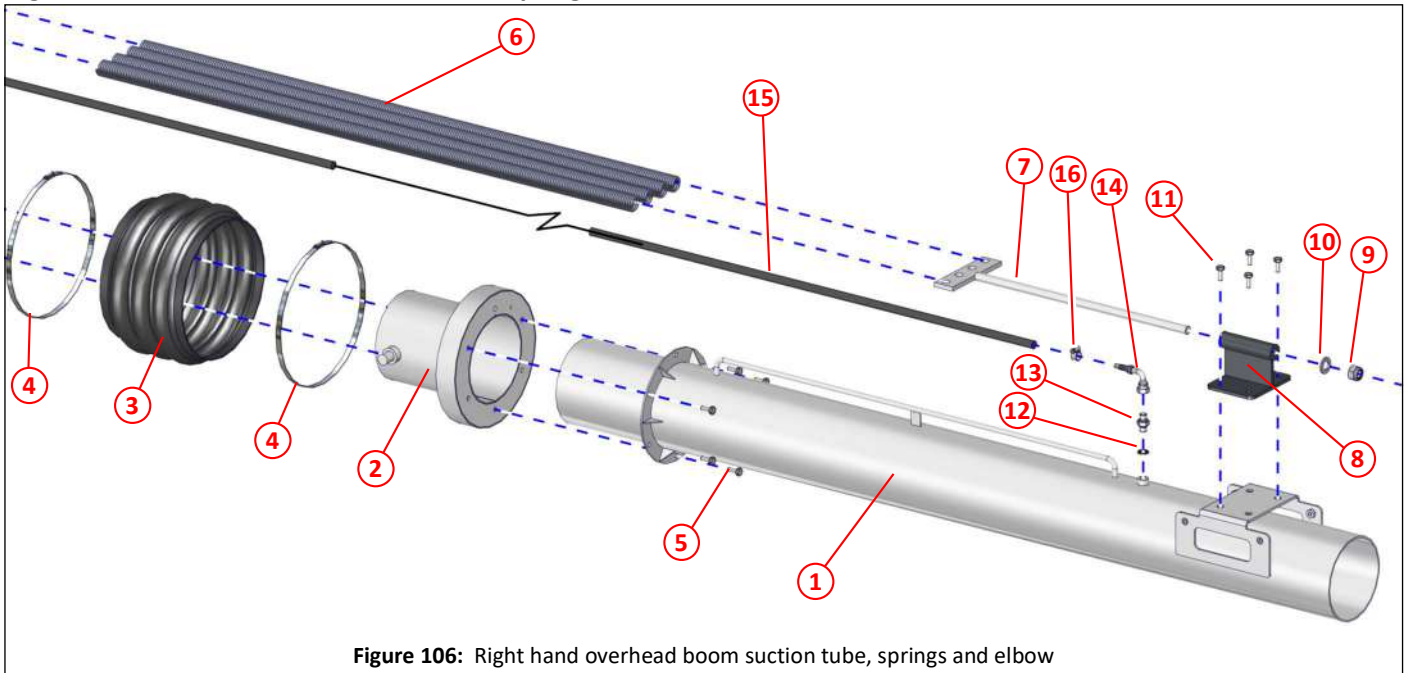

Figure 106: Right hand overhead boom suction tube, springs and elbow

Item	Part No	Qty	Description	
①	044120	1	Pipe, suction, overhead boom	131,134,136
②	044121	1	Pivot, overhead boom	134
③	044107	1	Cuff, overhead boom pivot	131,134
④	012933	2	Hose clamp, worm drive, No. 10.50 (ø235mm-ø267mm)	
⑤	011010	6	Set screw M8 x 20	
⑥	013805	4	Spring 800	131,134
⑦	013804	1	Tensioner, overhead boom	
⑧	044126	1	Bracket, spring tensioner	131
⑨	011060	1	Nyloc nut M16	
⑩	011135	1	Plain washer M16	
⑪	011010	4	Set screw M8 x 20	
⑫	011152	1	Dowty seal 1/4" BSP	
⑬	011158	1	Adapter 1/4" BSP	
⑭	002237	1	Adapter 1/4" BSPF x 3/8" hose tail, 90°	
⑮	010950	As req	Hose ø9.5 ID, black braided PVC	
⑯	010516	2	Hose clamp, worm drive, No. M00 (ø11mm-ø16mm)	

Right hand overhead boom suction hose and cradle

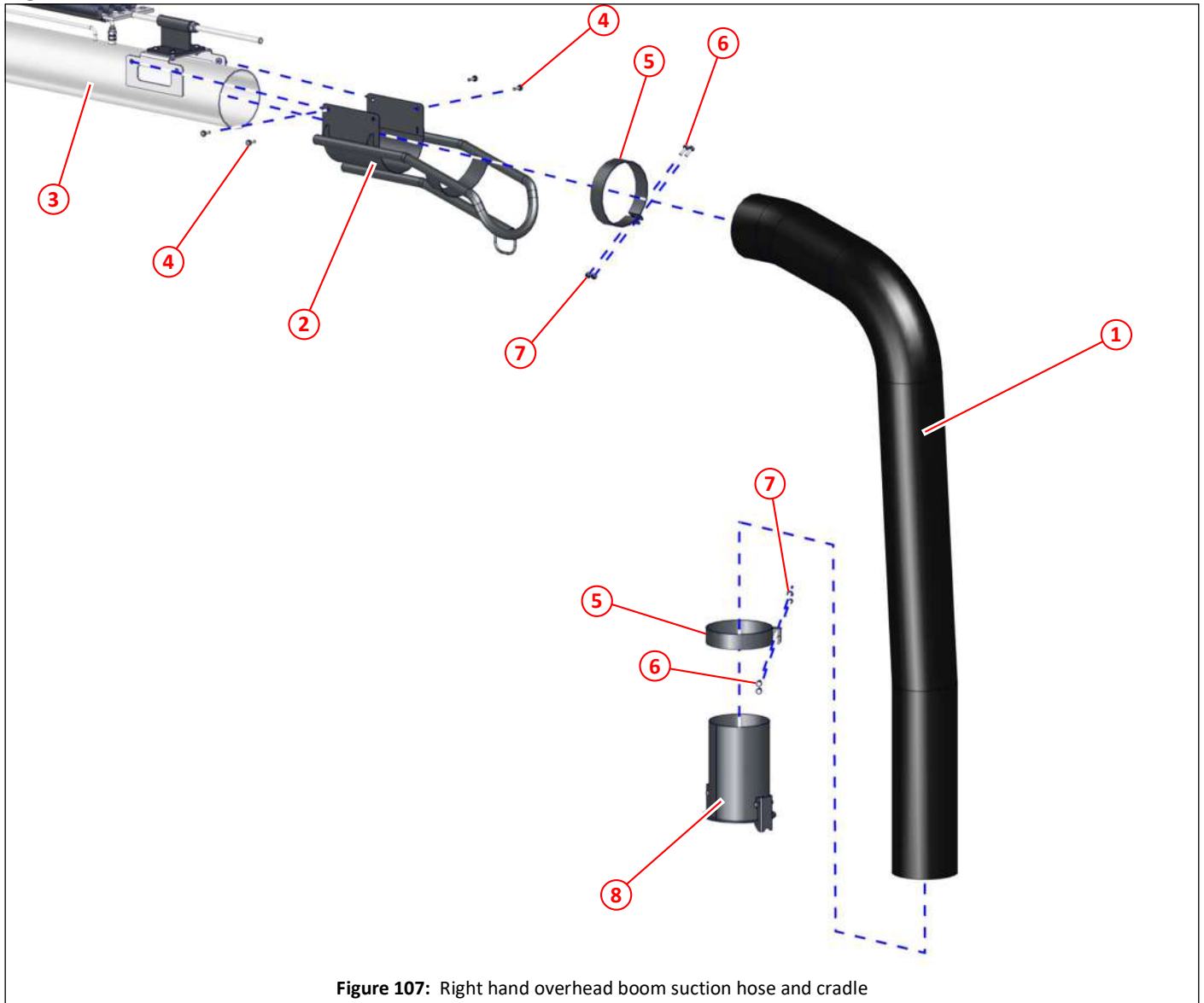

Figure 107: Right hand overhead boom suction hose and cradle

Item	Part No	Qty	Description	
①	044105	2m	Hose, overhead boom	131
②	044122	1	Cradle, overhead boom	131
③	044120	1	Pipe, suction, overhead boom	131,134,135
④	011010	4	Set screw M8 x 20	
⑤	044376	2	Clamp, hose, overhead boom	
⑥	000257	4	Set screw M8 x 25, stainless steel	
⑦	000263	4	Nyloc nut M8, stainless steel	
⑧	044124	1	Hose coupling, overhead boom	131

Right hand overhead boom locker door components

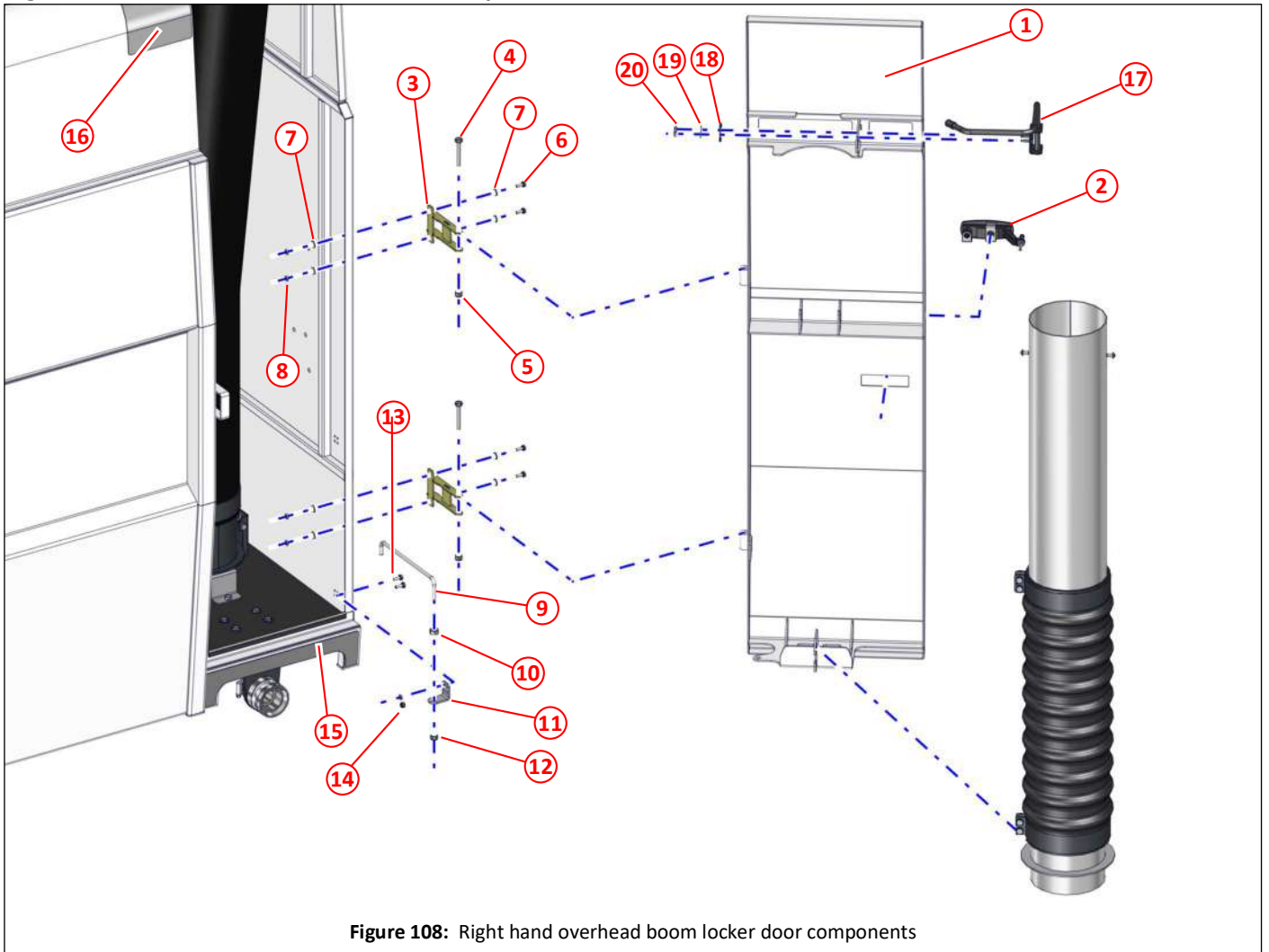

Figure 108: Right hand overhead boom locker door components

Item	Part No	Qty	Description	
①	044747	1	Door, locker, overhead boom, right hand	131
②	033115	1	Latch, locking	
③	044144	2	Hinge, locker door, overhead boom	
④	000261	2	Set screw M8 x 55, stainless steel	
⑤	000263	2	Nyloc nut M8, stainless steel	
⑥	000250	4	Set screw M6 x 16, stainless steel	
⑦	000254	4	Plain washer M6, stainless steel	
⑧	000253	4	Nyloc nut M6, stainless steel	
⑨	044407	1	Door stay, overhead boom	
⑩	011074	1	Full nut M10	
⑪	044408	1	Bracket, door stay, overhead boom	
⑫	000263	1	Nyloc nut M8, stainless steel	
⑬	011001	2	Set screw M6 x 16	
⑭	011071	2	Nyloc nut M6	
⑮	044383	1	Plate, locker protector, overhead boom	131,138
⑯	044384	1	Plate, hopper protector, overhead boom	131
⑰	045593	1	Hose protector right hand side	
⑱	027989	1	Plate, backing brace	
⑲	000254	2	Plain washer M6, stainless steel	
⑳	000253	2	Nyloc nut M6, stainless steel	



Right hand overhead boom stowage components

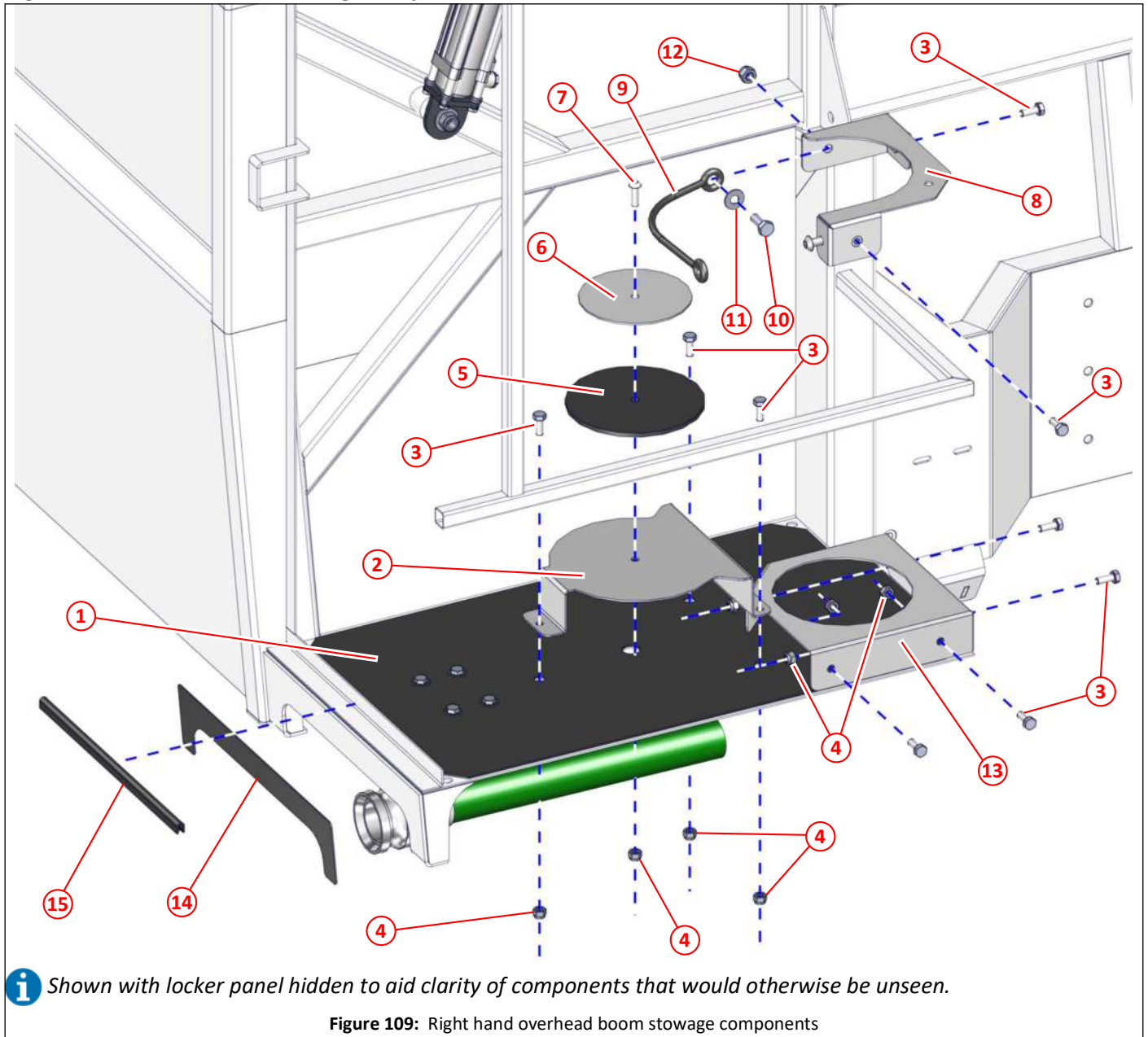

Figure 109: Right hand overhead boom stowage components

Item	Part No	Qty	Description	
①	044150	1	Rubber mat	
②	044127	1	Bracket, hose coupling stowage	
③	000256	9	Set screw M8 x 20, stainless steel	
④	000263	8	Nyloc nut M8, stainless steel	
⑤	044129	1	Sealing disc, rubber	
⑥	044130	1	Sealing plate	
⑦	000281	1	Socket button head screw, M8 x 25, stainless steel	
⑧	044752	1	Bracket, upper, extension stowage	
⑨	044007	1	Mini-tie No. 10	
⑩	000280	1	Set screw M10 x 25, stainless steel	
⑪	000270	1	Plain washer M10, stainless steel	
⑫	000269	1	Nyloc nut m10, stainless steel	
⑬	044149	1	Bracket, bottom, extension stowage	
⑭	044383	1	Plate, locker protector, overhead boom	131,137
⑮	010545	345mm	Titanfast, edging strip	



Overhead boom extension tubes

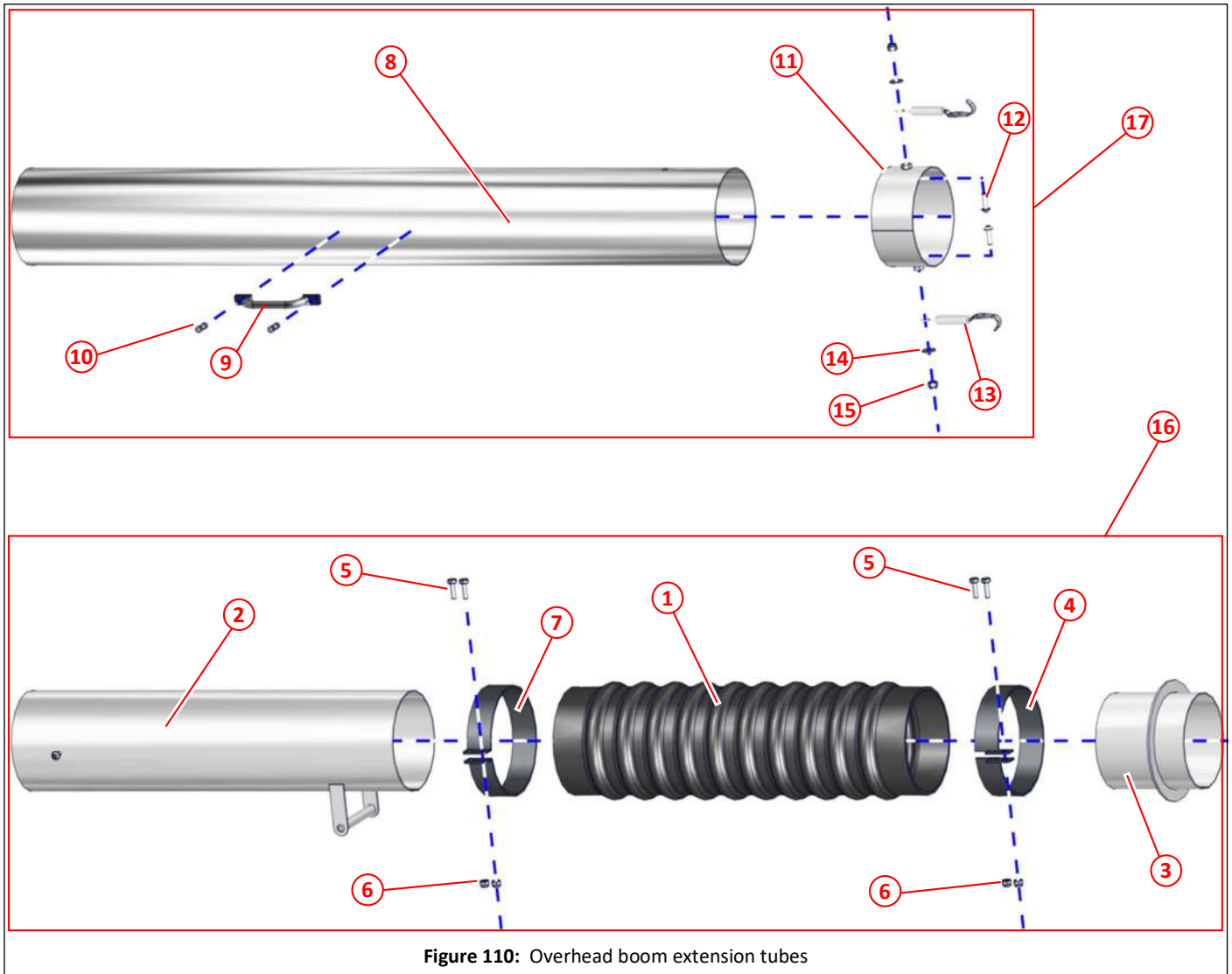

Figure 110: Overhead boom extension tubes

Item	Part No	Qty	Description	
①	044106	1	Hose, extension, overhead boom	
②	044141	1	Extension, overhead boom	
③	044140	1	Coupling, overhead boom extension	
④	036100	2	Clamp, hose, overhead boom	
⑤	000257	4	Set screw M8 x 25, stainless steel	
⑥	000263	4	Nyloc nut M8, stainless steel	
⑦	044376	1	Clamp, hose, overhead boom	
⑧	044153	1	Extension tube	
⑨	010502	1	Handle	
⑩	011131	4	Rivet, blind $\varnothing 4.8 \times 18$	
⑪	044154	1	Collar, overhead boom	
⑫	000281	2	Socket button head screw M8 x 25, stainless steel	
⑬	044014	2	Spring fastener, stainless steel	
⑭	000264	2	Plain washer M8, stainless steel	
⑮	000263	2	Nyloc nut M8, stainless steel	
⑯	044139	1	Extension, flexible, overhead boom, complete assembly	131
⑰	044155	1	Extension, overhead boom, complete assembly	131

Overhead boom water switch

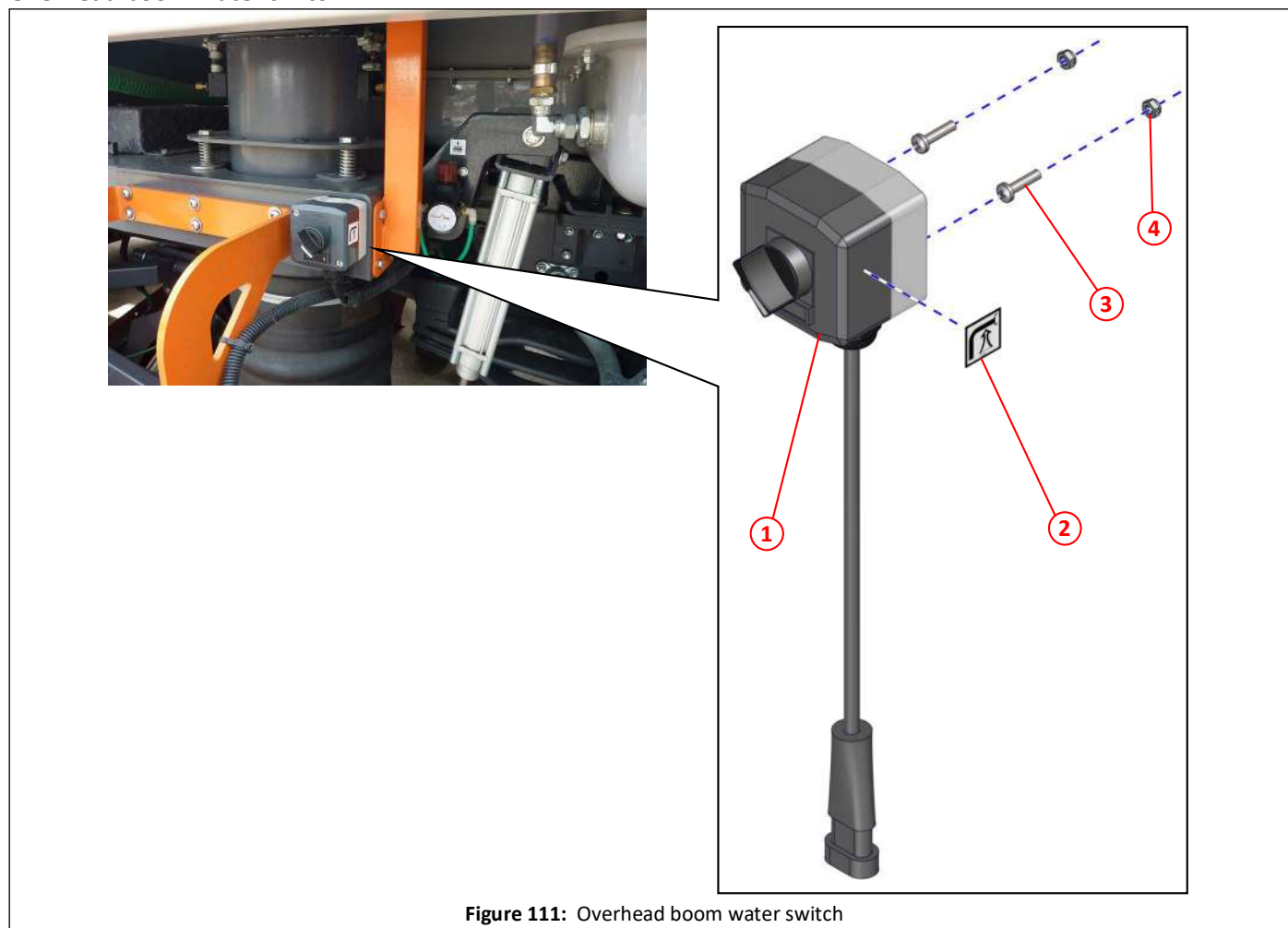

Figure 111: Overhead boom water switch

Item	Part No	Qty	Description	
①	036908	1	Switch and loom for over head boom water	330
②	039548	1	Label - Over head boom	453
③	000402	2	Pozidrive head, screw M5 x 20	
④	000155	2	Nyloc nut M5	

PU lined suction components

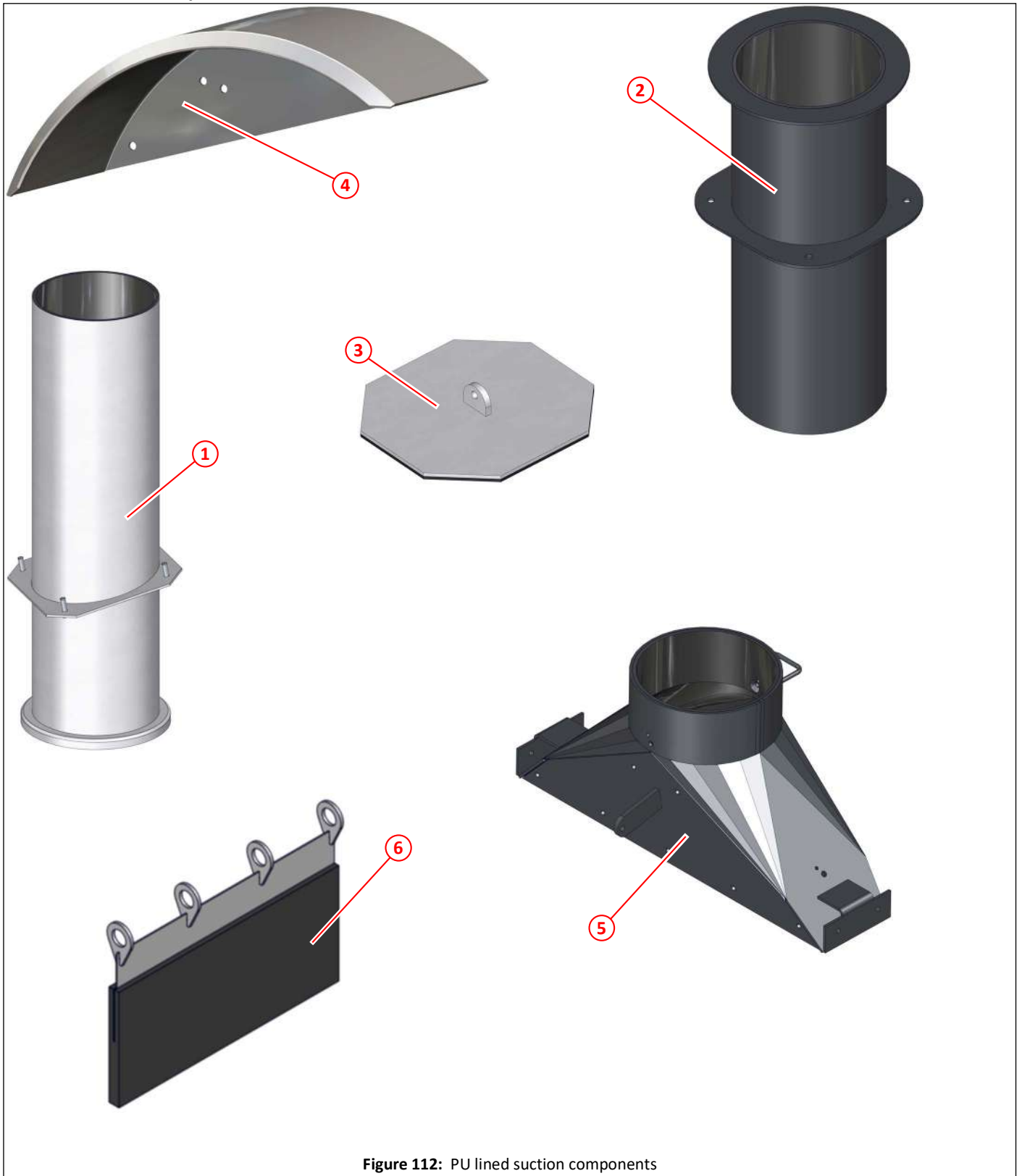

Figure 112: PU lined suction components

Item	Part No	Qty	Description	
①	051106	1	Tube, deflector, PU lined	
②	051137	1	Suction spigot, PU lined	
③	050717	1	Flap lid, auto blanking, PU lined	
④	050823	1	Deflector, PU lined	
⑤	050718	1	Suction nozzle, PU lined	
⑥	044606	1	Deflector swing plate, PU lined	



# Suction fan

<i>Description</i>	<i>Page</i>
Suction fan arrangement .....	144
Suction fan motor .....	145
Suction fan inlet cone and guard .....	146
Suction fan filter screen .....	147

Suction fan arrangement

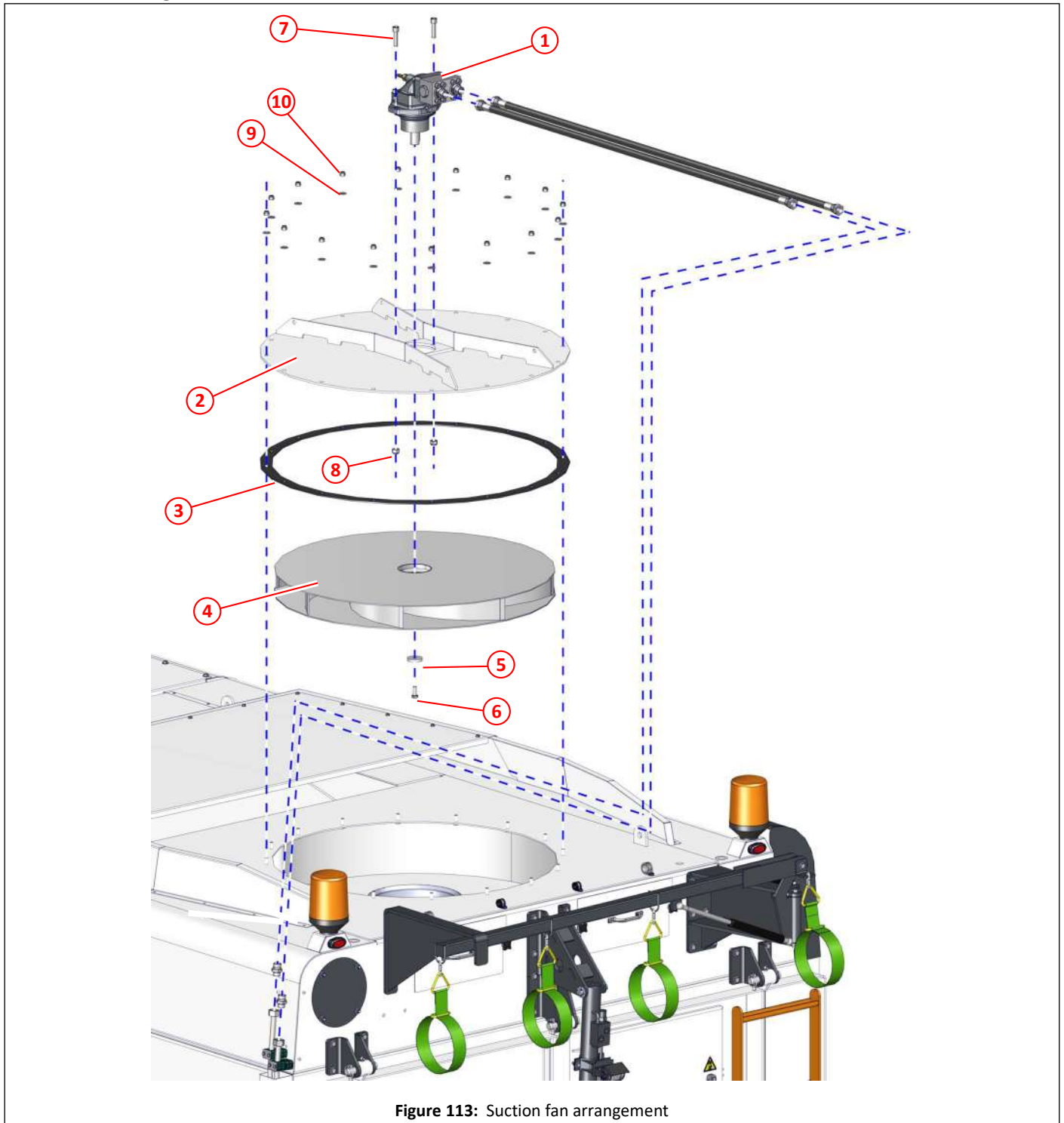

Figure 113: Suction fan arrangement

Item	Part No	Qty	Description	
①	044553	1	Fan Motor assembly145	145
②	024679	1	Fan plate (compact)	
③	010546	As req	Seal strip 3 x 38	
④	030651	1	Impeller, stainless steel	
⑤	044926	1	Washer $\phi 12.5 \times \phi 50 \times 8$ , stainless steel	
⑥	011052	1	Set screw M12 x 30	
⑦	000343	2	Socket cap head bolt M14 x 50, black	
⑧	011127	2	Nyloc nut M14	
⑨	011094	16	Plain washer M10	
⑩	011075	16	Nyloc nut M10	



Suction fan motor

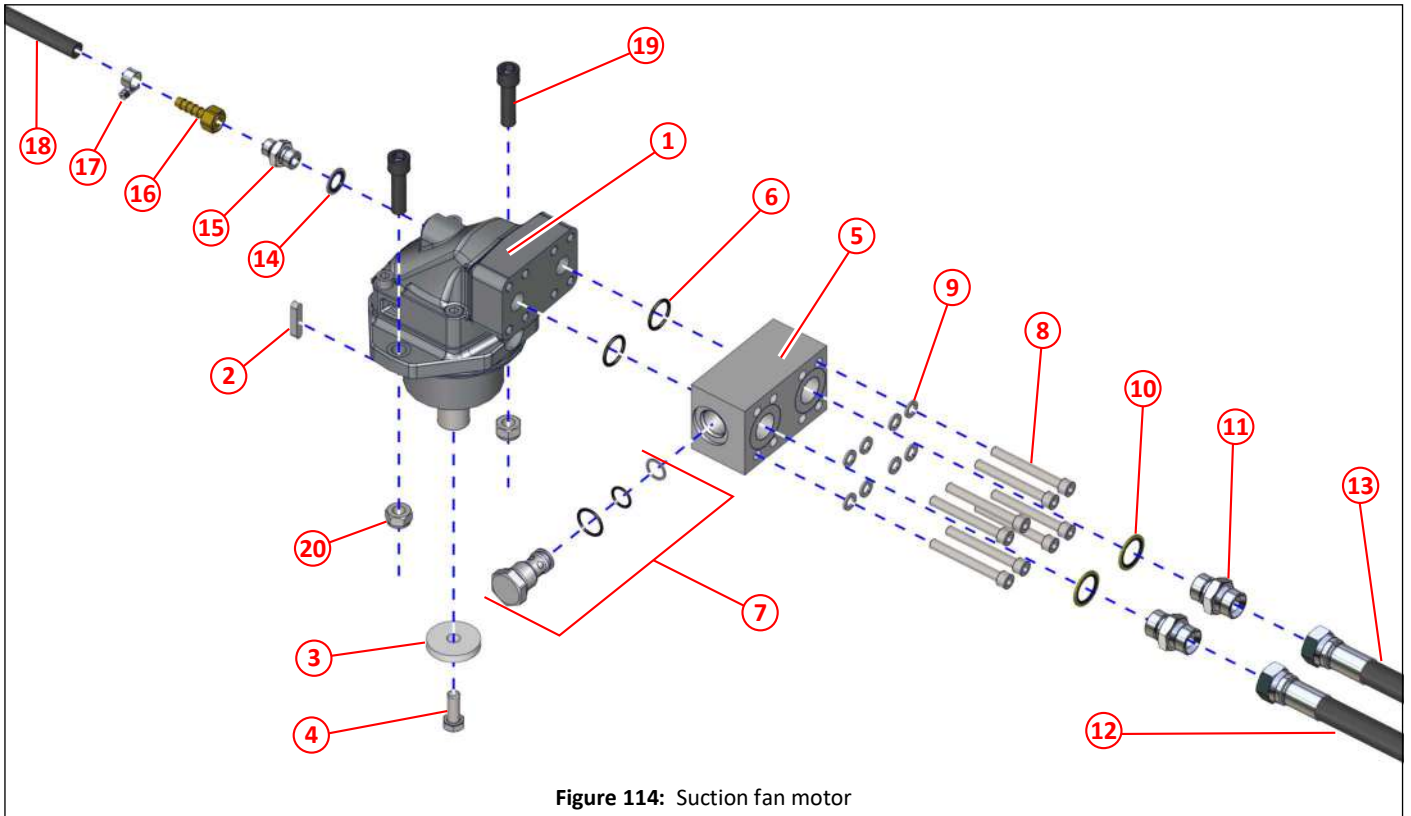

Figure 114: Suction fan motor

Item	Part No	Qty	Description	
①	024641	1	Fan motor	261
②	013292	1	Key for item ①	
③	044926	1	Washer $\phi 12.5 \times \phi 50 \times 8$ , stainless steel	
④	011052	1	Set screw M12 x 30	
⑤	041633*	1	Manifold, anti-cavitation valve	
⑥	041634*	2	'O' ring	
⑦	041635*	1	Check valve, includes seals and washer	
⑧	000048	8	Socket cap head screw M10 x 80	
⑨	011095	8	Spring washer M10	
⑩	011155	2	Dowty seal $\frac{3}{4}$ " BSP	
⑪	011161	2	Adapter $\frac{3}{4}$ " BSP	
⑫	001322	1	Hose $\frac{5}{8}$ " x 1550, $\frac{3}{4}$ " BSP straight ends	
⑬	001323	1	Hose $\frac{5}{8}$ " x 1700, $\frac{3}{4}$ " BSP straight ends	
⑭	011247	1	Dowty seal M18	
⑮	011248	1	Adapter M18 x $\frac{3}{8}$ " BSP	
⑯	010921	1	Adapter $\frac{3}{8}$ " BSP x $\frac{3}{8}$ " hose tail, complete with nut	
⑰	010516	1	Hose clamp, worm drive No. MOO ( $\phi 11\text{mm}-\phi 16\text{mm}$ )	
⑱	010958	As req	Hose $\frac{3}{8}$ "	
⑲	000343	2	Socket cap head bolt M14 x 50, black	
⑳	011127	2	Nyloc nut M14	

*	041564	1	Anti-cavitation valve assembly, includes items ⑤, ⑥ and ⑦	
---	--------	---	---	--

Suction fan inlet cone and guard

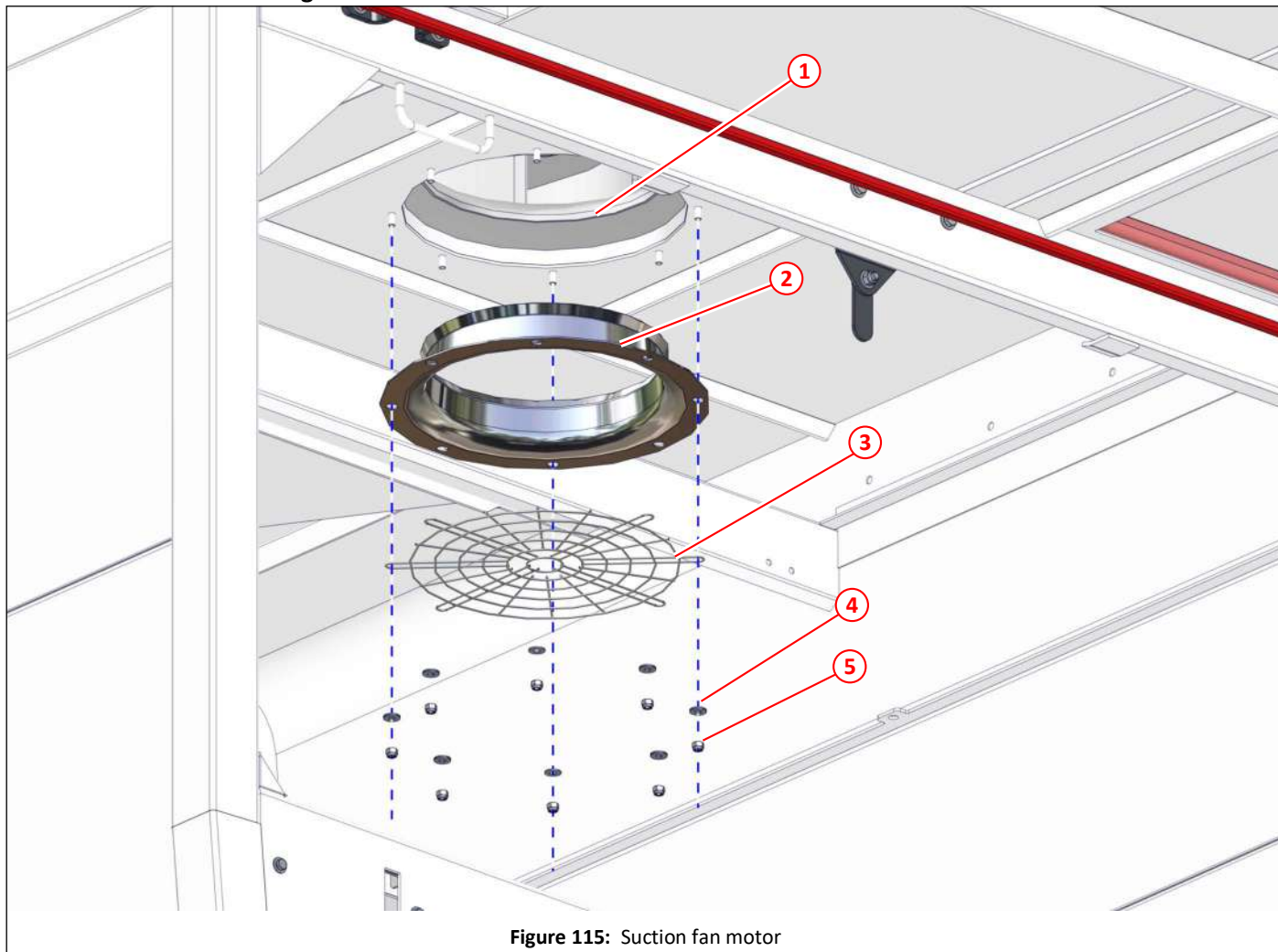

Figure 115: Suction fan motor

Item	Part No	Qty	Description	
①	030651	1	Impeller, stainless steel	144
②	032357	1	Inlet cone, stainless steel	171
③	039674	1	Guard, fan	171
④	000264	8	Plain washer, M8, stainless steel	
⑤	000263	8	Nyloc nut M8, stainless steel	

Suction fan filter screen

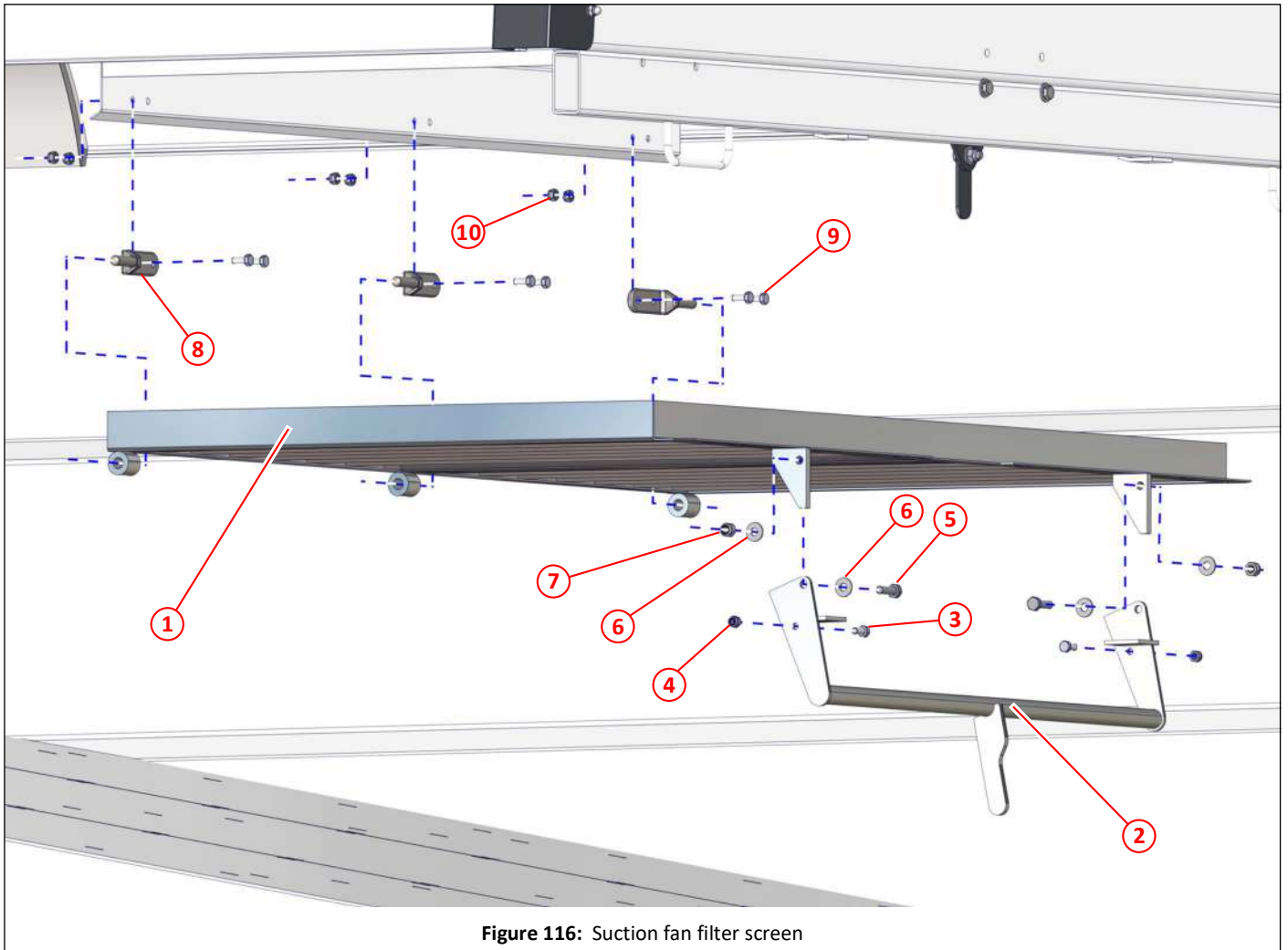

Figure 116: Suction fan filter screen

Item	Part No	Qty	Description	
①	031883	1	Screen, filter, suction fan, stainless steel	171
②	039312	1	Latch, long handle, screen	171
③	000256	2	Set screw M8 x 20, stainless steel	
④	000263	2	Nyloc nut, M8, stainless steel	
⑤	000462	2	Set screw M10 x 35, stainless steel	
⑥	011094	4	Plain washer M10	
⑦	011075	2	Nyloc nut M10	
⑧	025245	3	Gudgeon	
⑨	000256	6	Set screw M8 x 20, stainless steel	
⑩	000263	6	Nyloc nut, M8, stainless steel	



# Hopper and body

<i>Description</i>	<i>Page</i>
Hopper and body arrangement, external	150
Hopper and body arrangement, external	151
Hopper unit	152
Hopper cover	153
Hopper pivot pins and bushes	154
Hopper lift ram pivot	155
Hopper safety prop roller	156
Hopper locker covers	157
Hopper capping	158
Cover, wander hose duct	159
Blanking plugs on hopper rear panel with no rear wander hose	160
Hopper rear marker LEDs, hose and wiring clips	161
Fan inspection cover, external	162
Fan inspection cover, internal	163
Fan inspection cover with wash assist, internal	164
Locker door, right hand side	165
Locker door, left hand side	166
Hopper chutes	167
Pipework, hopper rear, left hand side	168
Pipework, hopper rear, right hand side	169
Hopper and body arrangement, internal	170
Hopper and body arrangement, internal	171
Suction fan inlet cone and guard	172
Suction fan filter screen	173
Safety latch, suction fan filter screen	174
Hopper blanking for single sweep	175
Hopper locker items, fan scraper, door safety prop, hydrant filler	176
Hydrant filler fittings and mountings	177
Rear door arrangement, overview	178
Rear door, with right hand inspection/access hatch	179
Rear door, with left hand inspection/access hatch	180
Hinges, rear door	181
Inspection/access hatch, right hand	182
Inspection/access hatch, left hand	183
Ladder and grab rail, rear door, right hand side	184
Ladder and grab rail, rear door, left hand side	185
Lay flat hose, rear door, hopper drain	186
Rear door open/close/locking arrangement	187
Hinge, rear door ram	188
Ram, rear door open/close/lock	189
Locking bar, rear door	190
Locking cam, rear door	191
Locking wear plates, rear door	192
Rear camera mountings	193
Direction sign, rear door mounted	194

Hopper and body arrangement, external

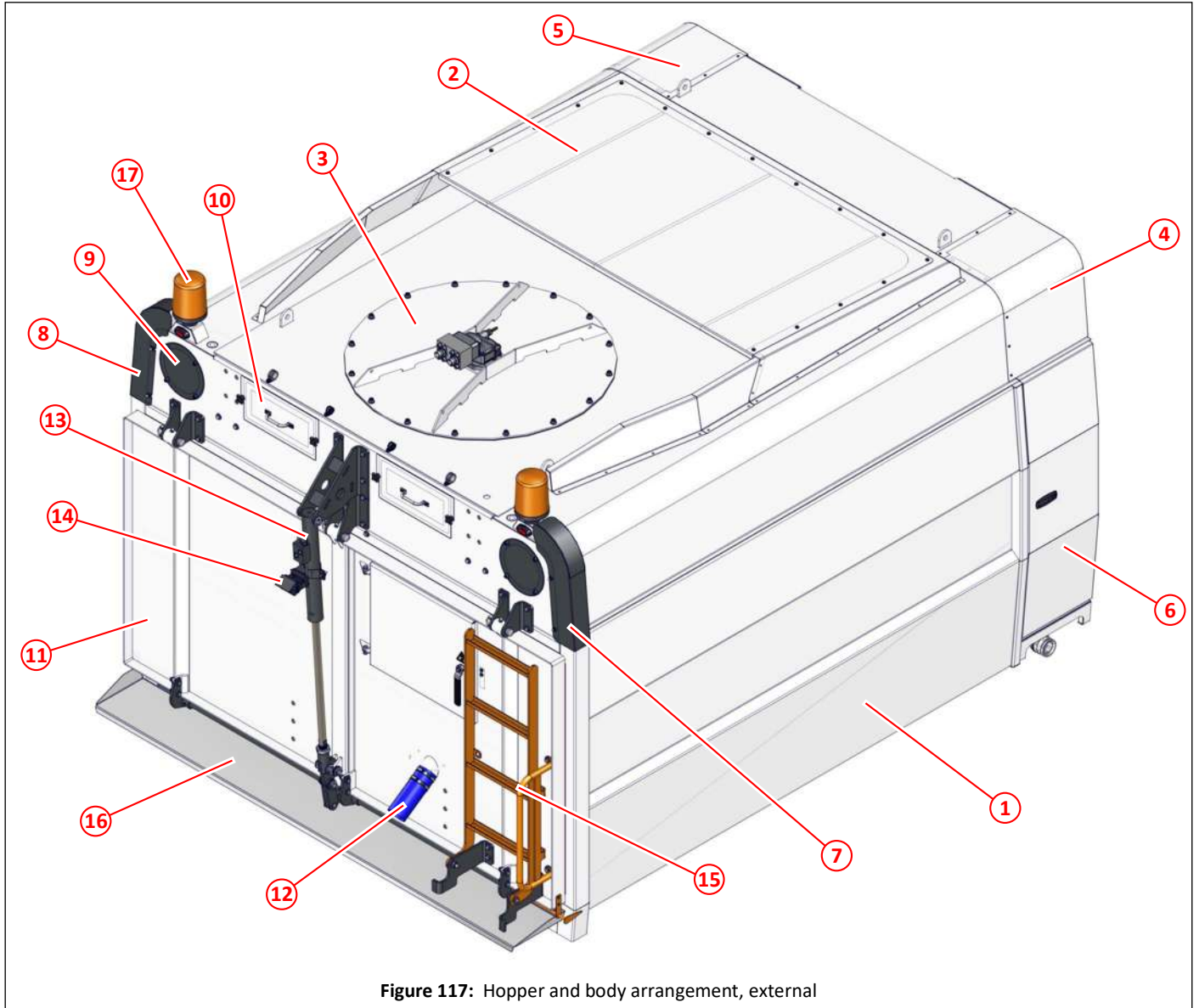

Figure 117: Hopper and body arrangement, external

Item	Part No	Qty	Description	
①	044685	1	Hopper, fully welded	152
②	040042	1	Lid, cover frame, hopper	153
③			Suction fan	144
④	044689	1	Cover, hopper locker, right hand side	157
⑤	044688	1	Cover, hopper locker, left hand side	157
⑥	044691	1	Door, locker, right hand side	165
⑦	040018	1	Capping, right hand side	158
⑧	043723	1	Capping, left hand side	158
⑨	025486	1	Cover plate, wander hose duct	159
⑩		2	Cover, inspection, outer	162
⑪			Door, rear	178,179,180
⑫	010998	1.5m	Hose, lay flat	178,179,180,186
⑬	034816	1	Ram, door opening and locking	189,272
⑭	040354	1	Camera, rear, standard fitting displayed on CANbus screen	178,329
⑮			Ladder and handle	183,184
⑯			Chute, hopper	167
⑰			Beacon	328



## Hopper and body arrangement, external

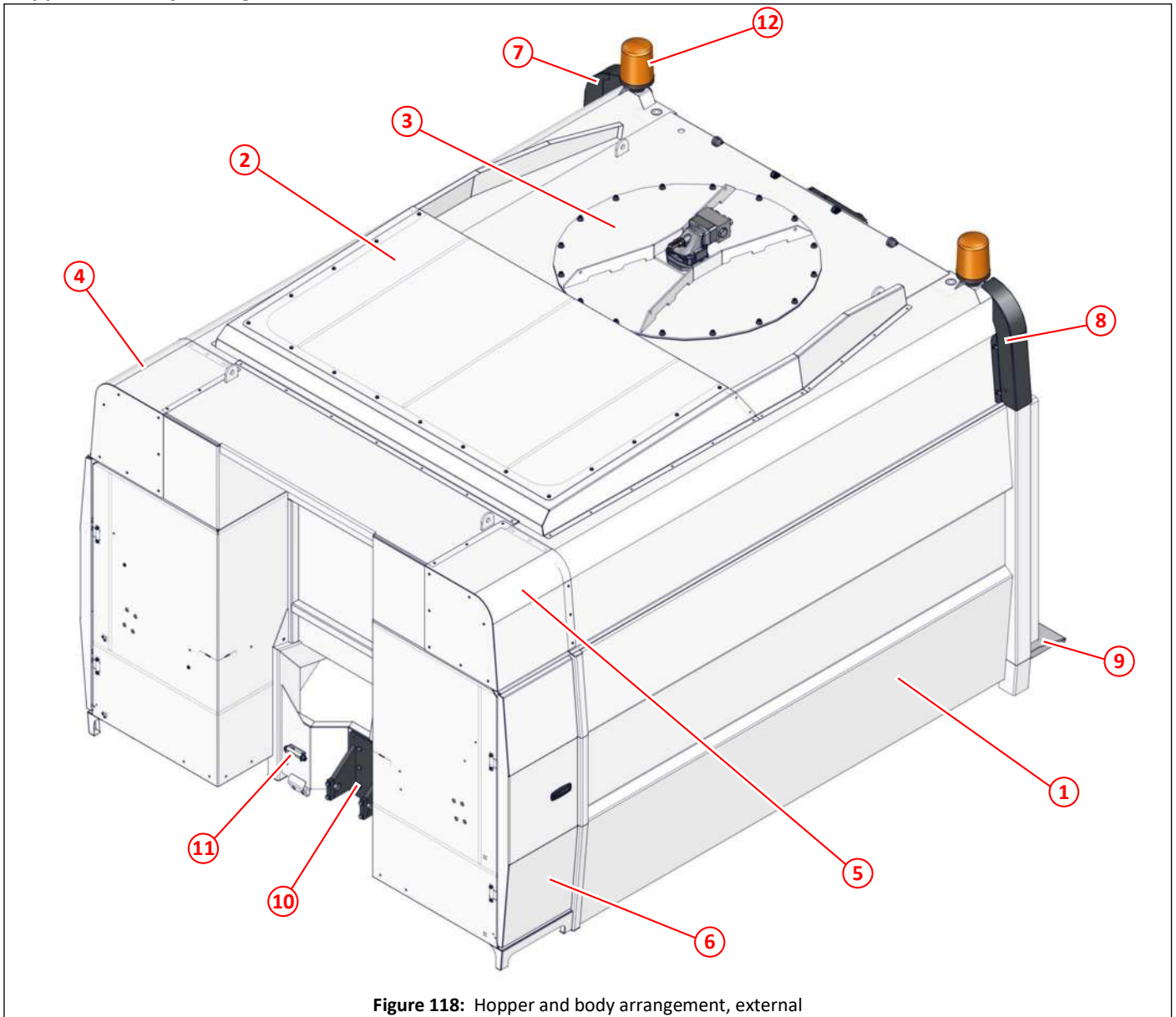
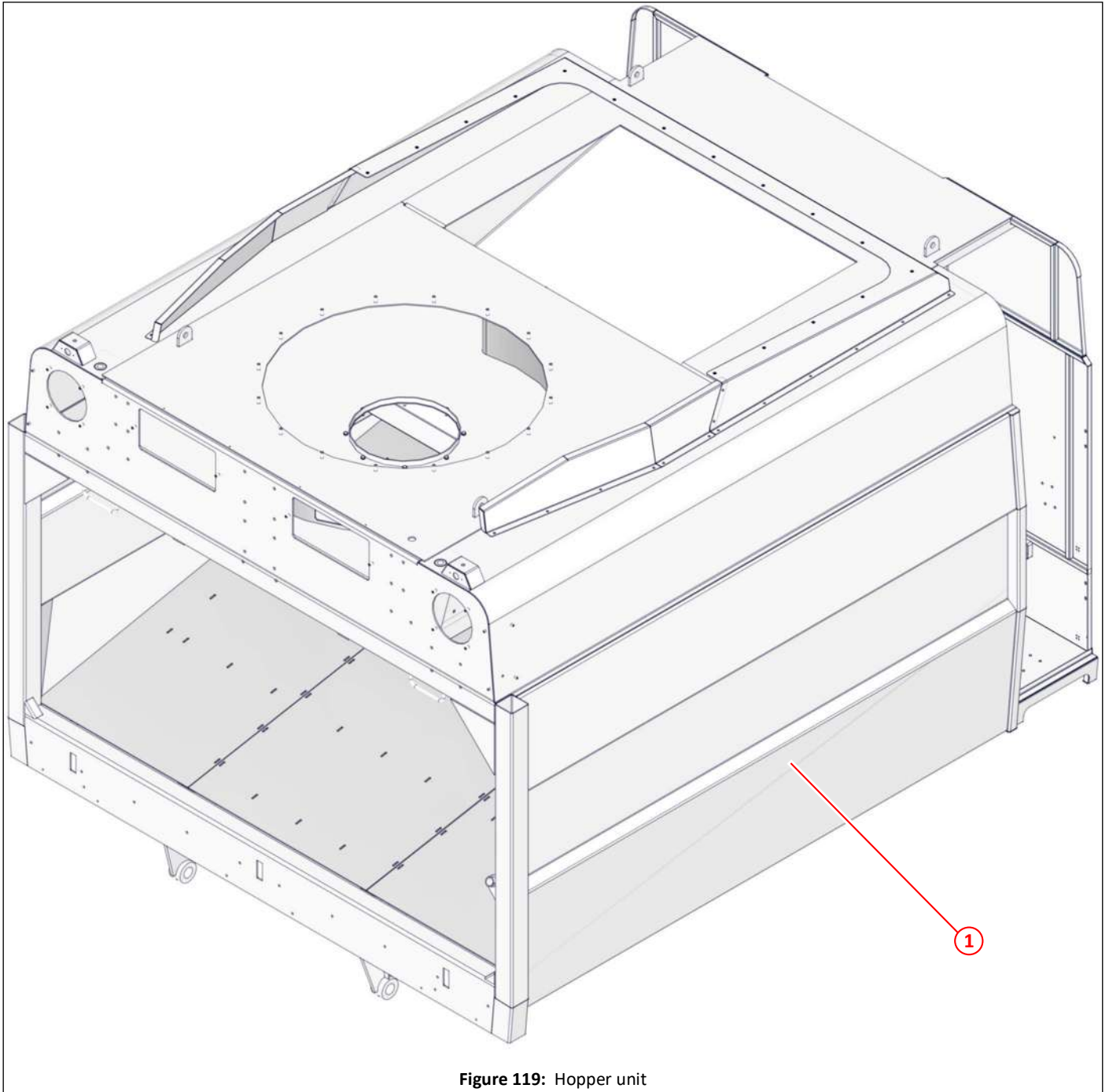

Figure 118: Hopper and body arrangement, external

Item	Part No	Qty	Description	
①	044685	1	Hopper, fully welded	152
②	040042	1	Lid, cover frame, hopper	153
③			Suction fan	144
④	044689	1	Cover, hopper locker, right hand side	157
⑤	044688	1	Cover, hopper locker, left hand side	157
⑥	044690	1	Door, locker, left hand side	166
⑦	040018		Capping, hopper, right hand side	158
⑧	043723		Capping, hopper, left hand side	158
⑨			Chute, hopper	167
⑩	010719	1	Pivot, hopper lift ram	155
⑪			Roller, safety prop	156
⑫			Beacon	328

## Hopper unit



Item	Part No	Qty	Description
①	044685	1	Hopper, fully welded

Hopper cover

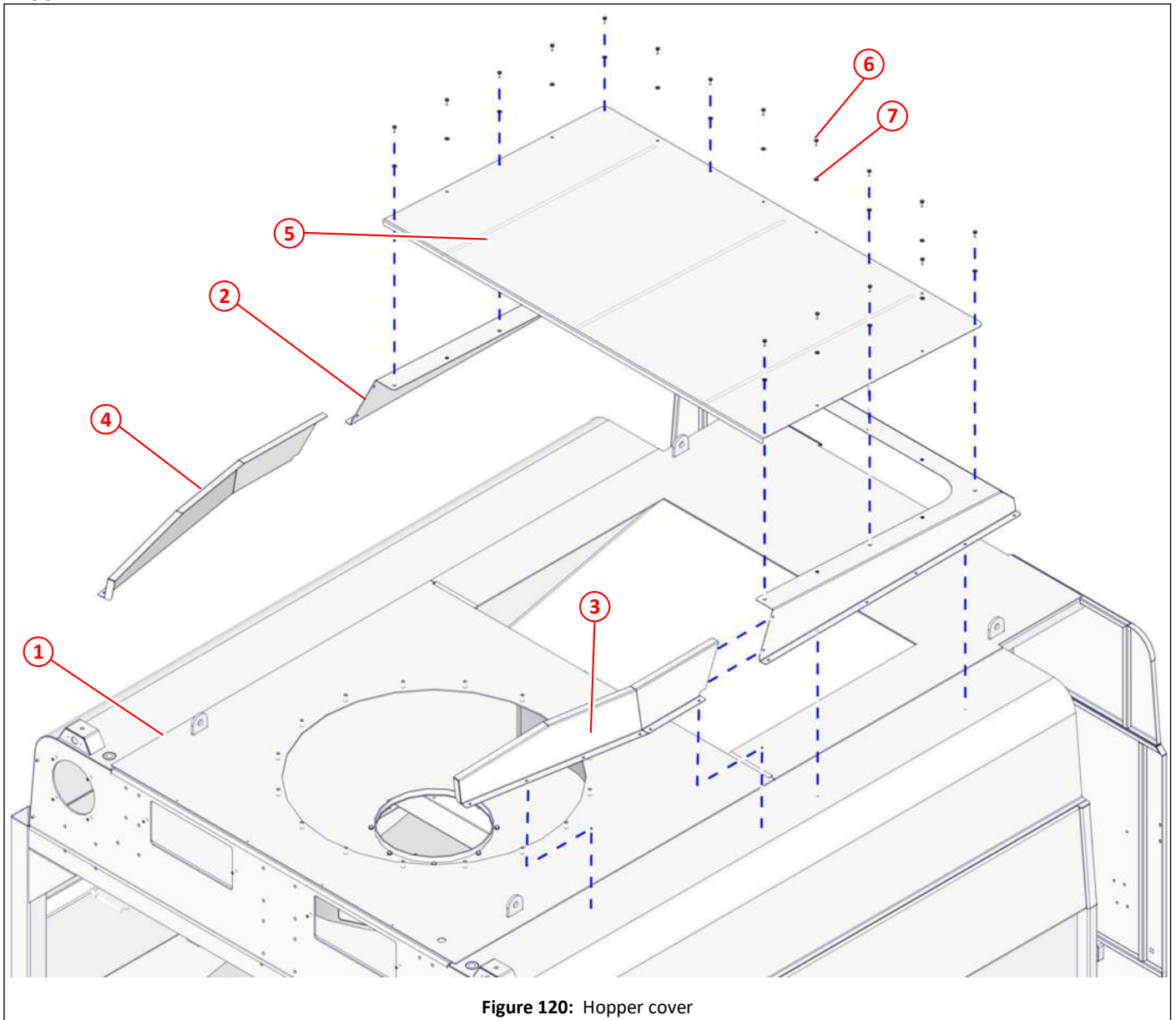

Figure 120: Hopper cover

Item	Part No	Qty	Description	
①	044685	1	Hopper, fully welded	152
②	040041	1	Cover frame, hopper, welded to hopper	
③	044718	1	Extension, cover frame, hopper, right hand side, welded to hopper	
④	044080	1	Extension, cover frame, hopper, left hand side, welded to hopper	
⑤	040042	1	Lid, cover frame, hopper	
⑥	011001	16	Set screw M6 x 16	
⑦	011090	16	Plain washer M6	

## Hopper pivot pins and bushes

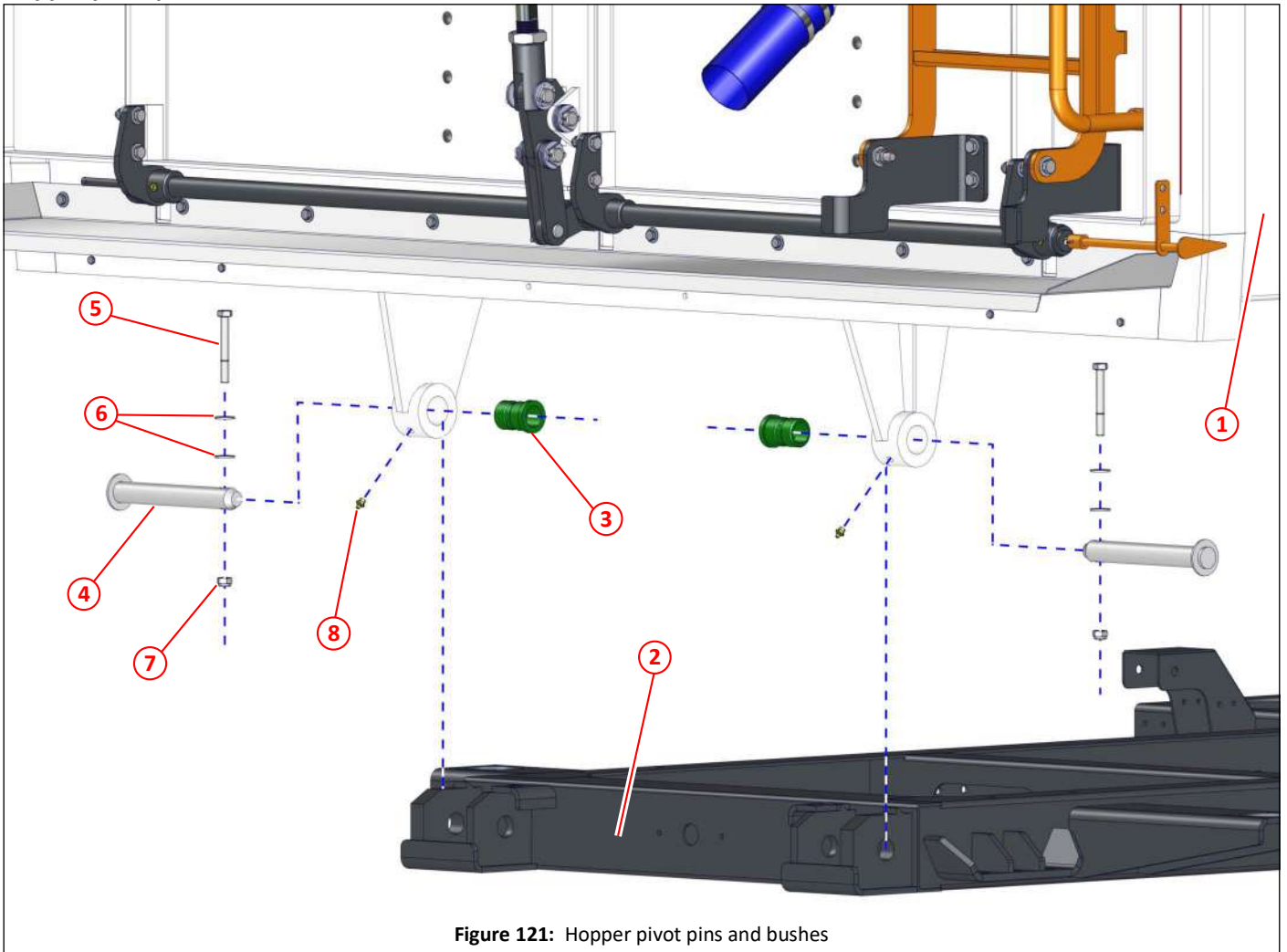

Figure 121: Hopper pivot pins and bushes

Item	Part No	Qty	Description	
①	044685	1	Hopper, fully welded	152
②	042942	1	Subframe	365,366
③	020336	2	Bush	
④	034391	2	Pivot pin, hopper	
⑤	000139	2	Bolt M12 x 90	
⑥	011096	4	Plain washer M12	
⑦	011077	2	Nyloc nut M12	
⑧	010903	2	Grease nipple $\frac{1}{8}$ " BSP, straight	

Hopper lift ram pivot

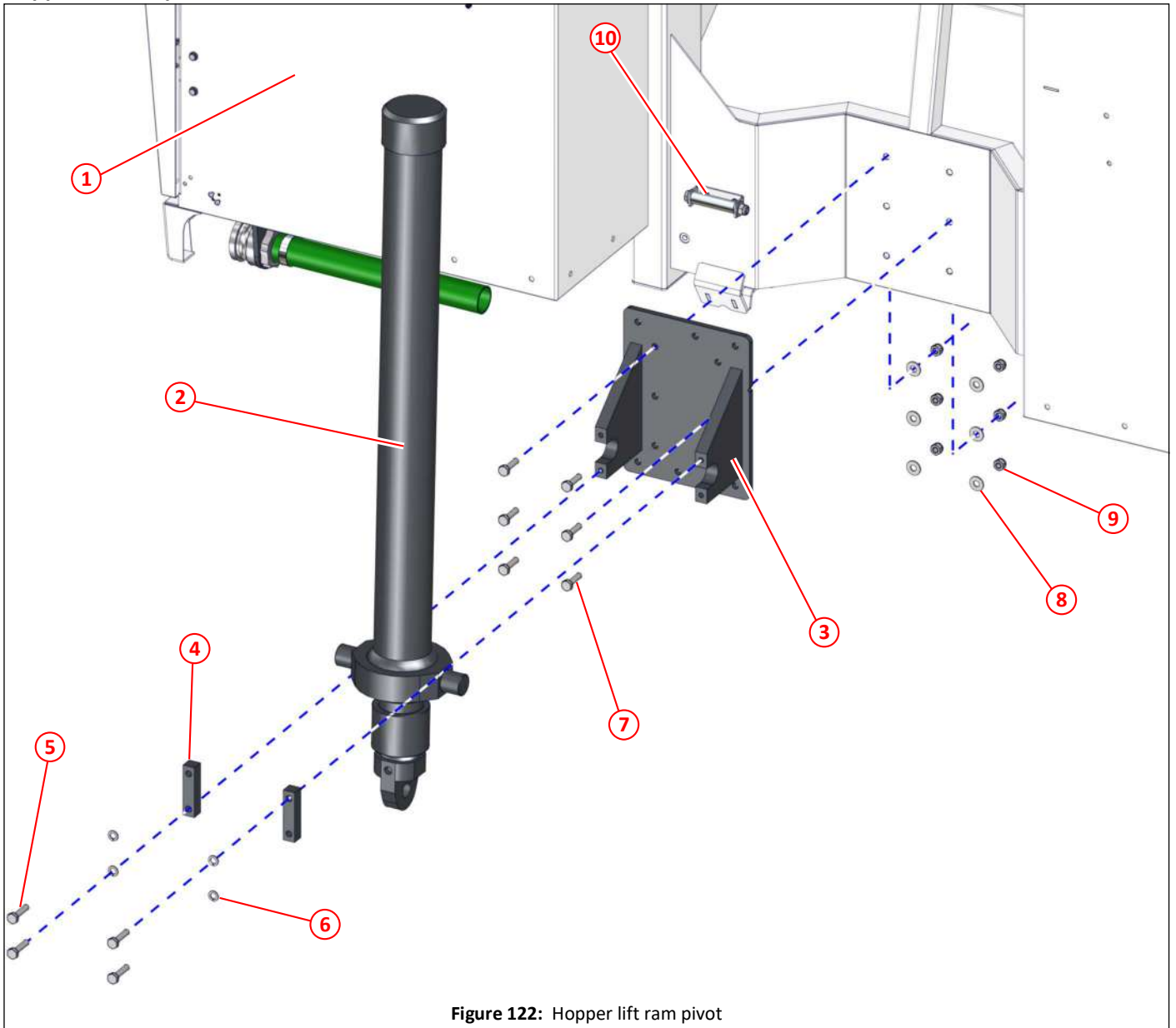

Figure 122: Hopper lift ram pivot

Item	Part No	Qty	Description	
①	044685	1	Hopper, fully welded	152
②	024249	1	Ram, dual acting, hopper	271
③	010719	1	Pivot, hopper ram	
④	034395	1	Pivot bar, hopper ram	
⑤	011034	4	Set screw M10 x 40	
⑥	011095	4	Spring washer M10	
⑦	011033	6	Set screw M10 x 35	
⑧	011094	6	Plain washer M10	
⑨	011075	6	Nyloc nut M10	
⑩			Guide, hopper safety prop	156



## Hopper safety prop roller

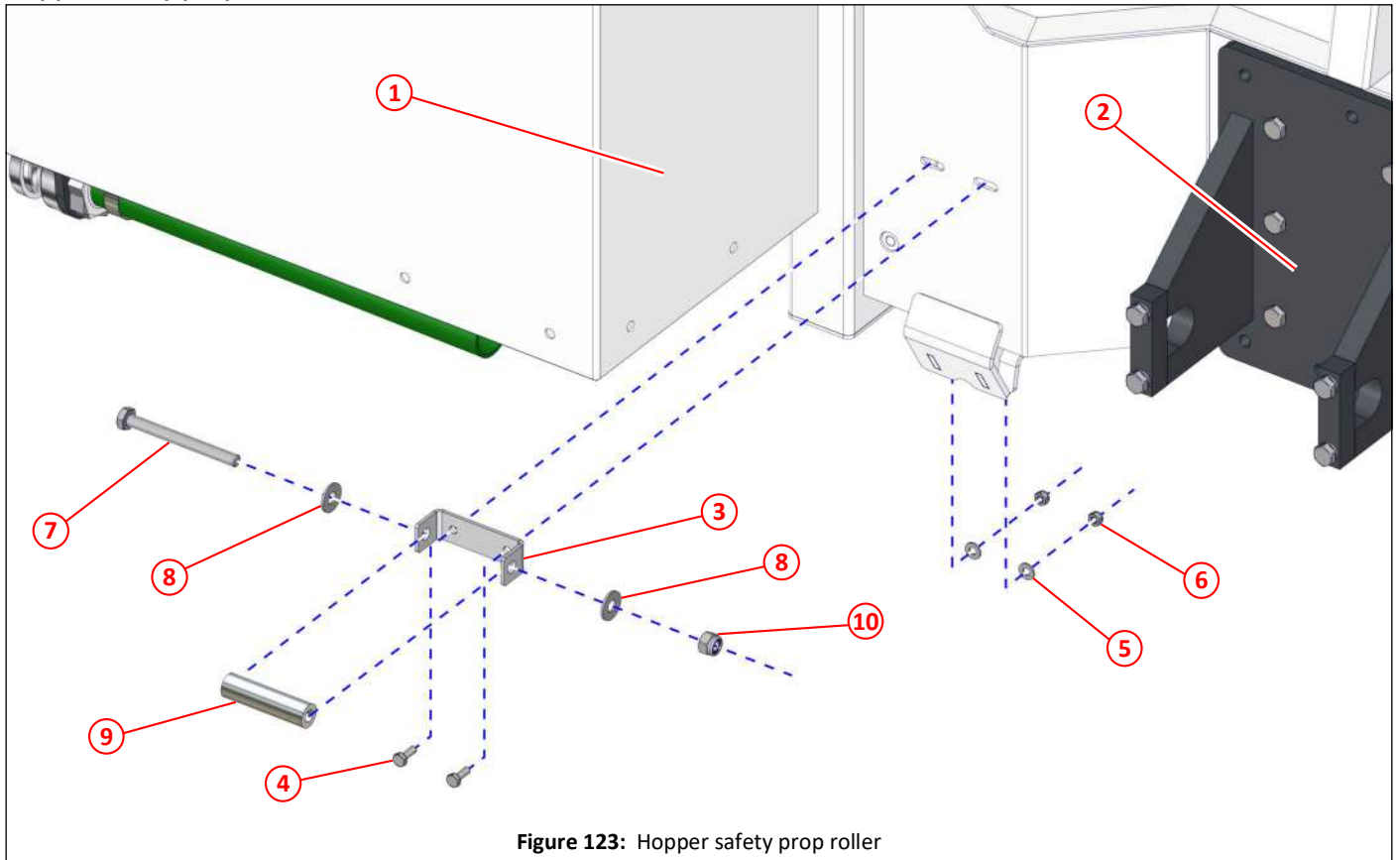
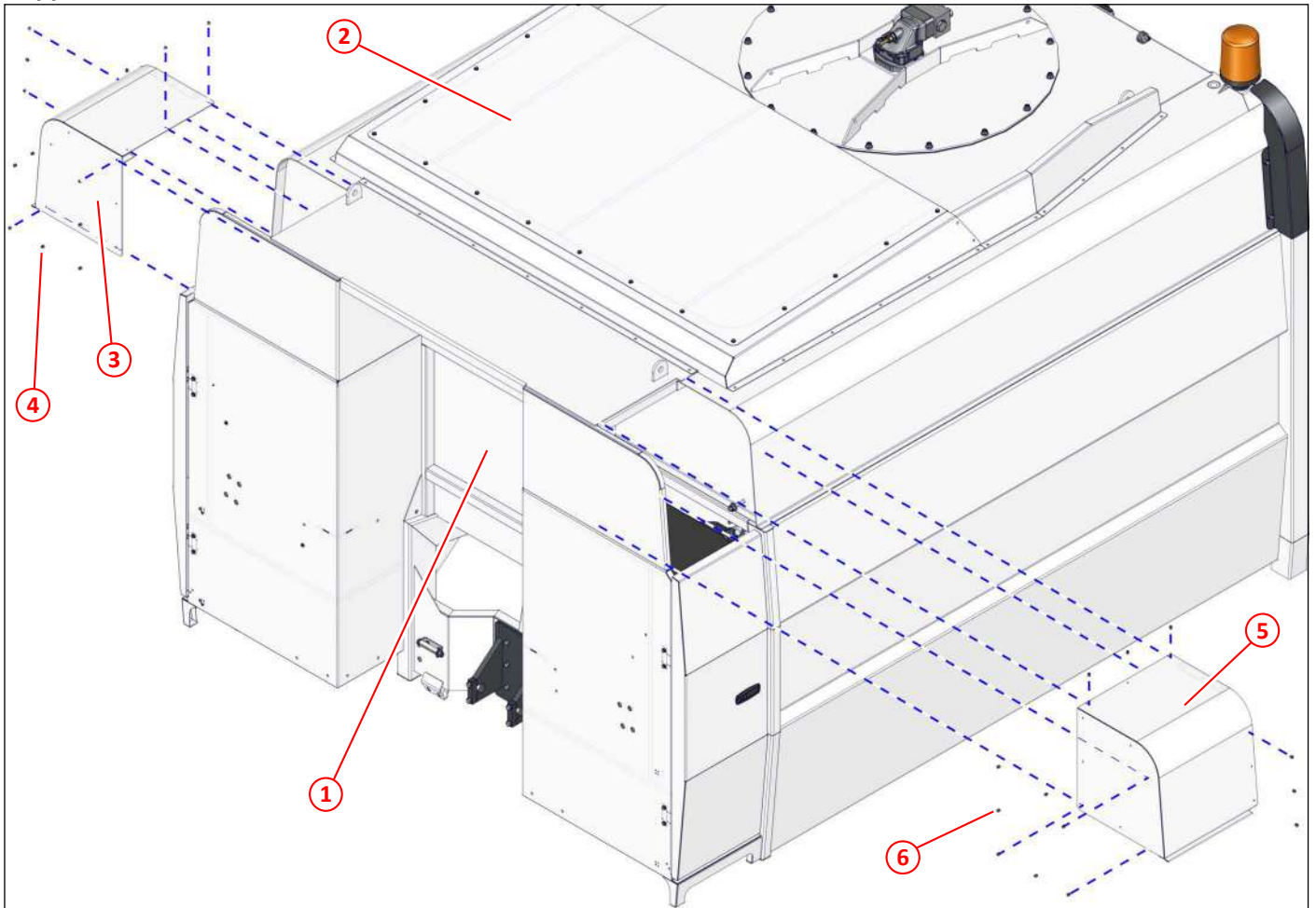

Figure 123: Hopper safety prop roller

Item	Part No	Qty	Description	
①	044685	1	Hopper, fully welded	152
②	010719	1	Pivot, hopper ram	155
③	034379	1	Bracket, hopper safety prop guide. For hopper safety prop, see page 368.	
④	011001	2	Set screw M6 x 16	
⑤	011090	2	Plain washer M6	
⑥	011071	2	Nyloc nut M6	
⑦	011039	1	Bolt M10 x 100	
⑧	011094	2	Plain washer M10	
⑨	011711	1	Roller, spacer $\phi 10.5 \times \phi 20 \times 5$	
⑩	011075	1	Nyloc nut M10	



Hopper locker covers



**i** Only one of these locker covers will be on a sweeper with an over head boom.

Figure 124: Hopper locker covers

Item	Part No	Qty	Description
①	044685	1	Hopper, fully welded
②	040042	1	Lid, cover frame, hopper
③	044689	1	Cover, hopper locker, right hand side
④	011131	13	Rivet, blind $\varnothing 4.8 \times 18$
⑤	044688	1	Cover, hopper locker, left hand side
⑥	011131	13	Rivet, blind $\varnothing 4.8 \times 18$

## Hopper capping

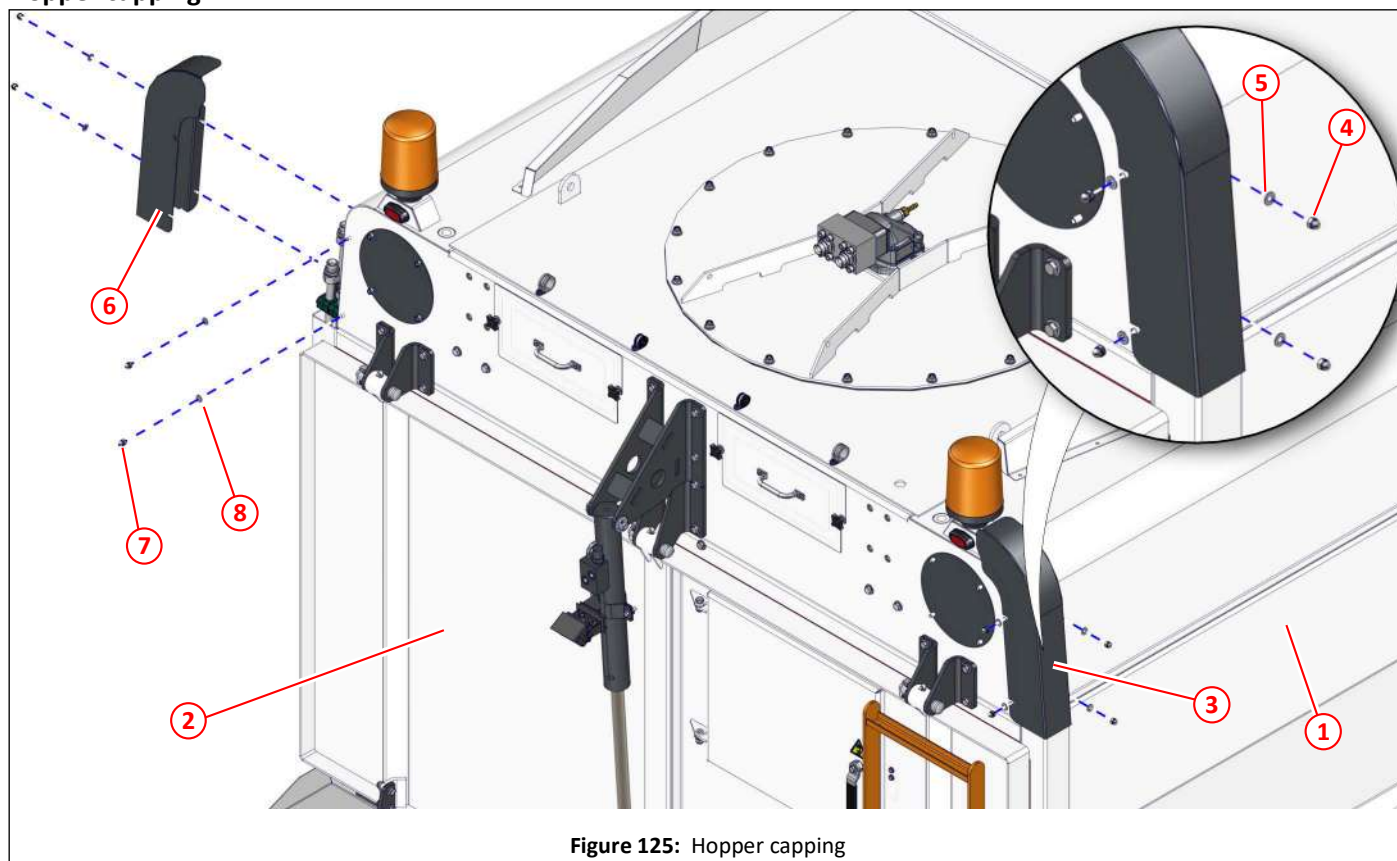

Figure 125: Hopper capping

Item	Part No	Qty	Description	
①	044685	1	Hopper, fully welded	
②			Rear door	178
③	040018	1	Capping, right hand side	
④	000089	4	Dome nut M8	
⑤	000419	4	Plain washer M8, ø17	
⑥	043723	1	Capping, left hand side	
⑦	000089	4	Dome nut M8	
⑧	000419	4	Plain washer M8, ø17	

Cover, wander hose duct

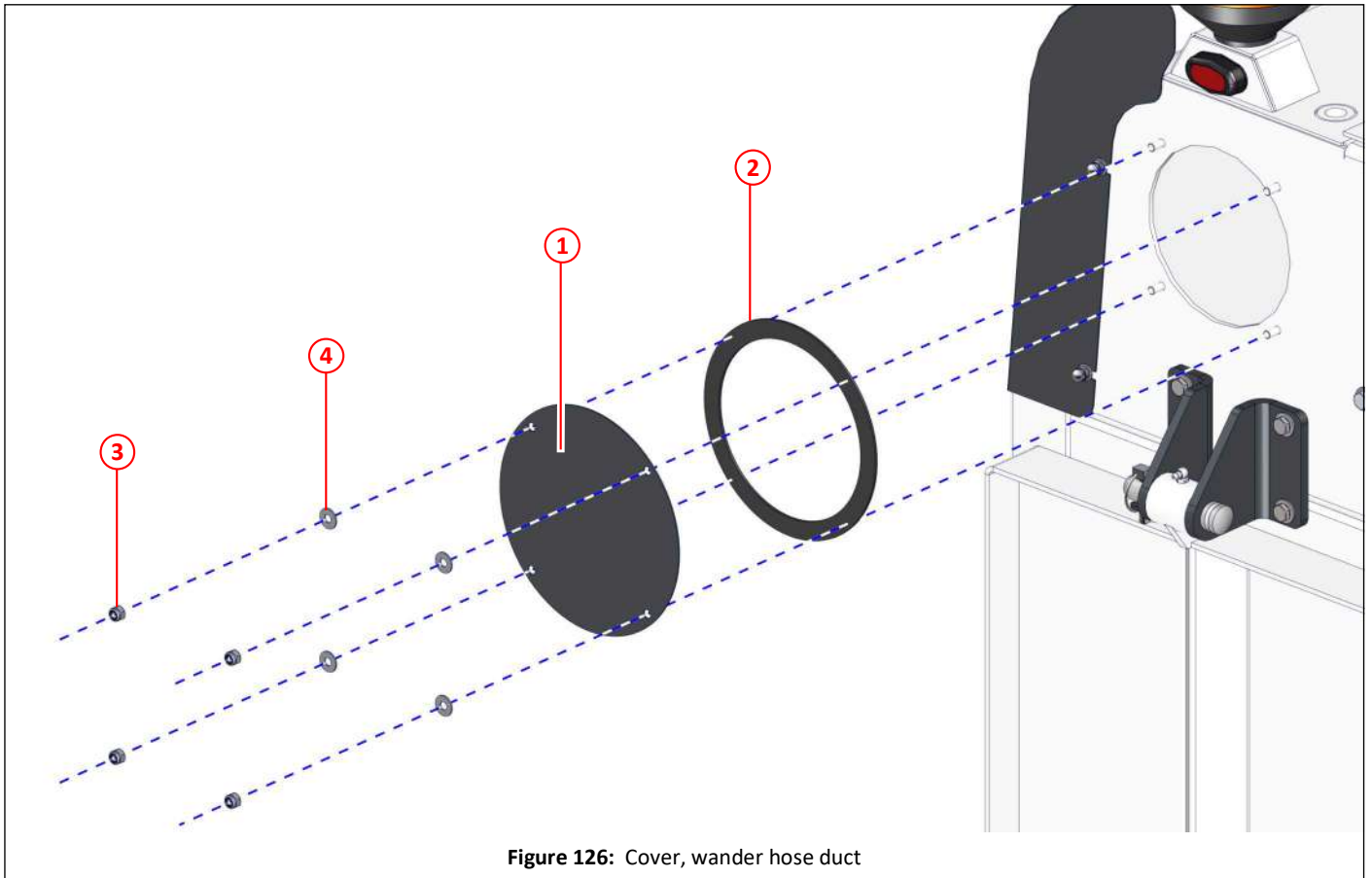

Figure 126: Cover, wander hose duct

Item	Part No	Qty	Description
①	025486	1	Cover, wander hose duct
②	013645	As req	Seal strip 3 x 19
③	000263	4	Nyloc nut N8, stainless steel
④	000264	4	Plain washer M8, stainless steel

## Blanking plugs on hopper rear panel with no rear wander hose

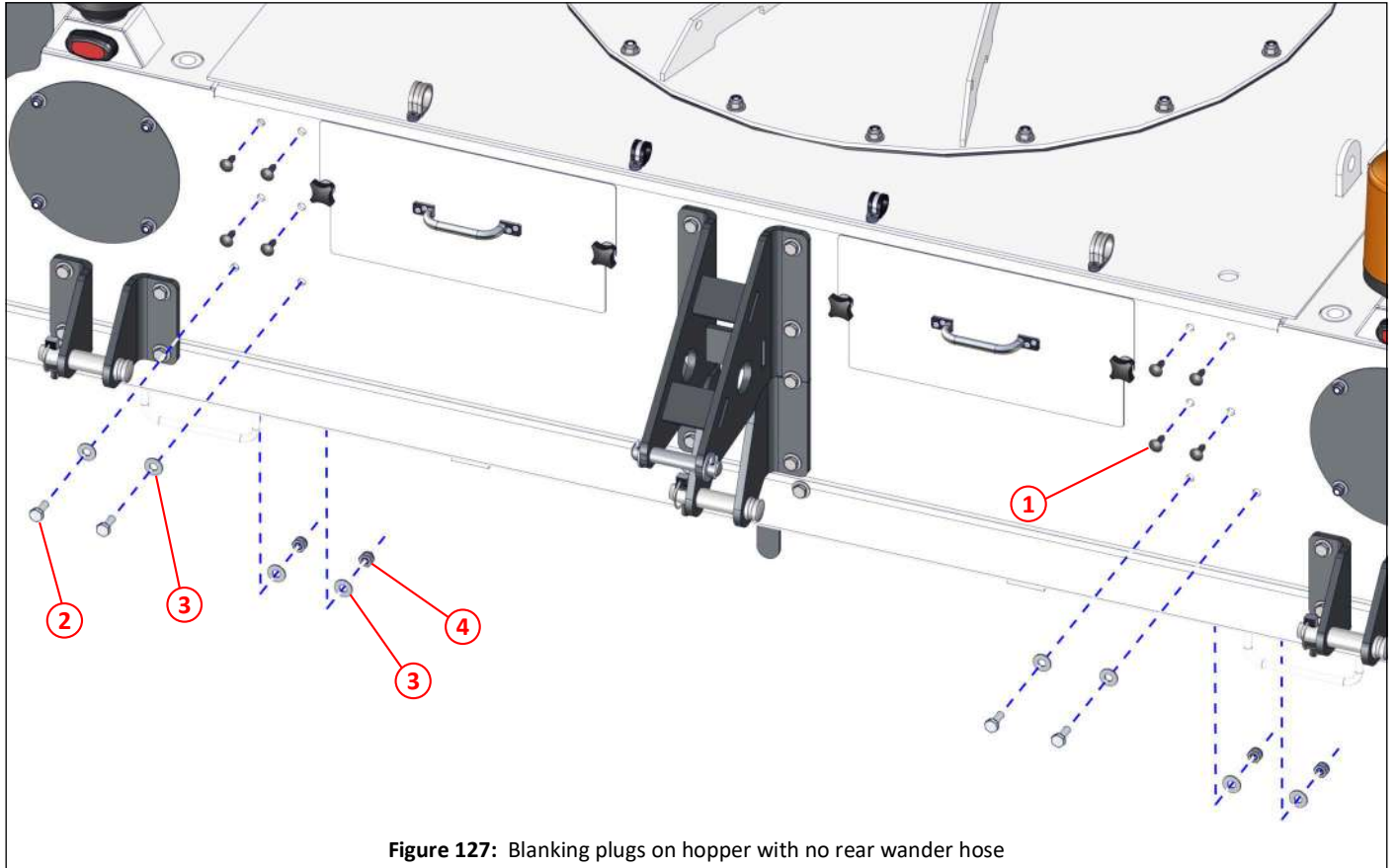

Figure 127: Blanking plugs on hopper with no rear wander hose

Item	Part No	Qty	Description
①	014563	8	Button, fir tree
②	000280	4	Set screw M10 x 25, stainless steel
③	000270	8	Plain washer M10, stainless steel
④	000269	4	Nyloc nut M10, stainless steel

Hopper rear marker LEDs, hose and wiring clips

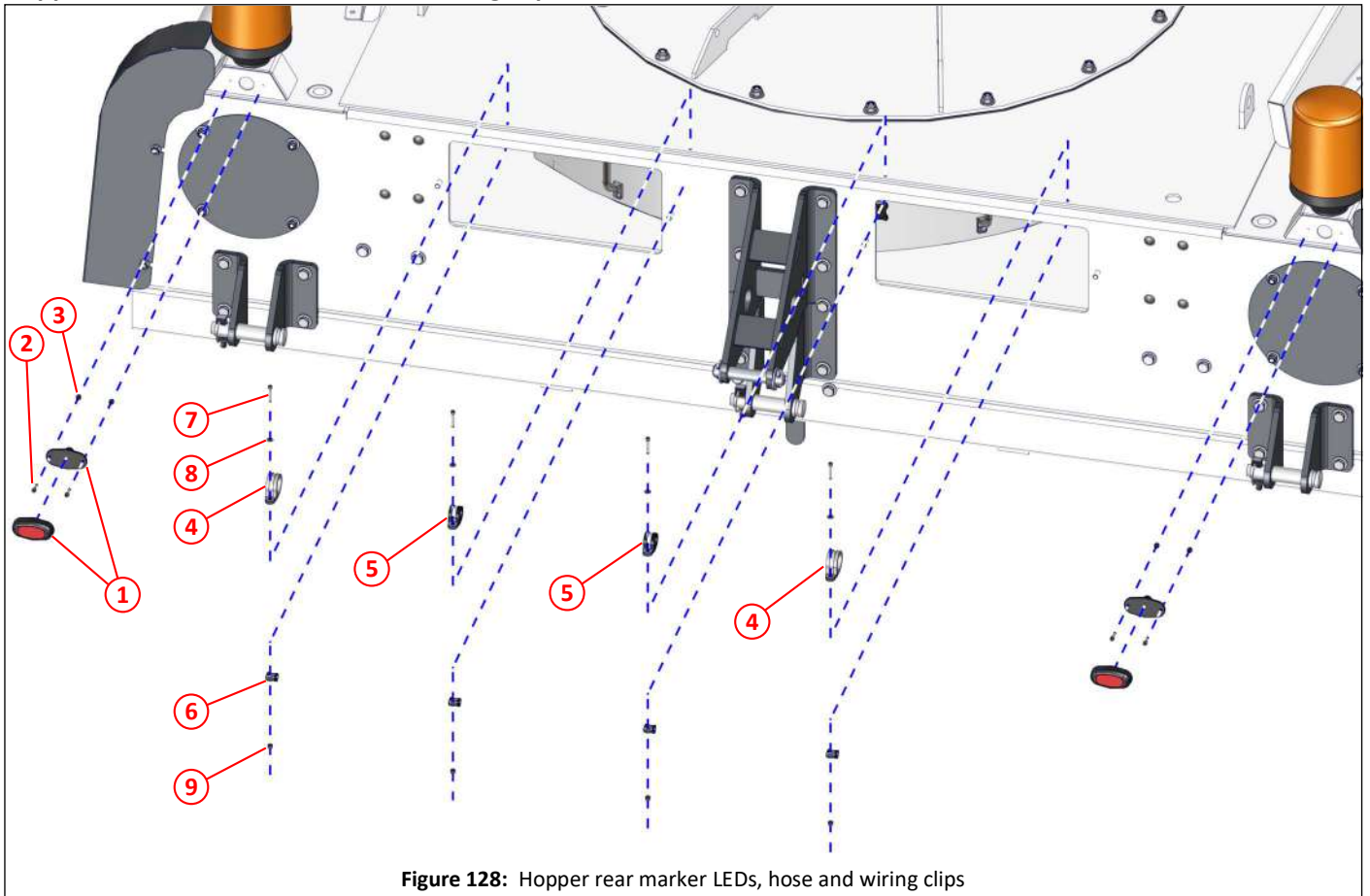

Figure 128: Hopper rear marker LEDs, hose and wiring clips

Item	Part No	Qty	Description
①	030773	2	Marker lamp, LED 12v/24v
②	000142	4	Socket cap head screw M4 x 15, plated
③	000134	4	Nyloc nut M4
④	024705	2	P-Clip, ø35
⑤	005059	2	P-Clip, ø25
⑥	021914	4	P-Clip, ø12
⑦	000191	4	Socket cap head screw M4 x 25, plated
⑧	000410	4	Plain washer M5
⑨	000134	4	Nyloc nut M4



Fan inspection cover, external

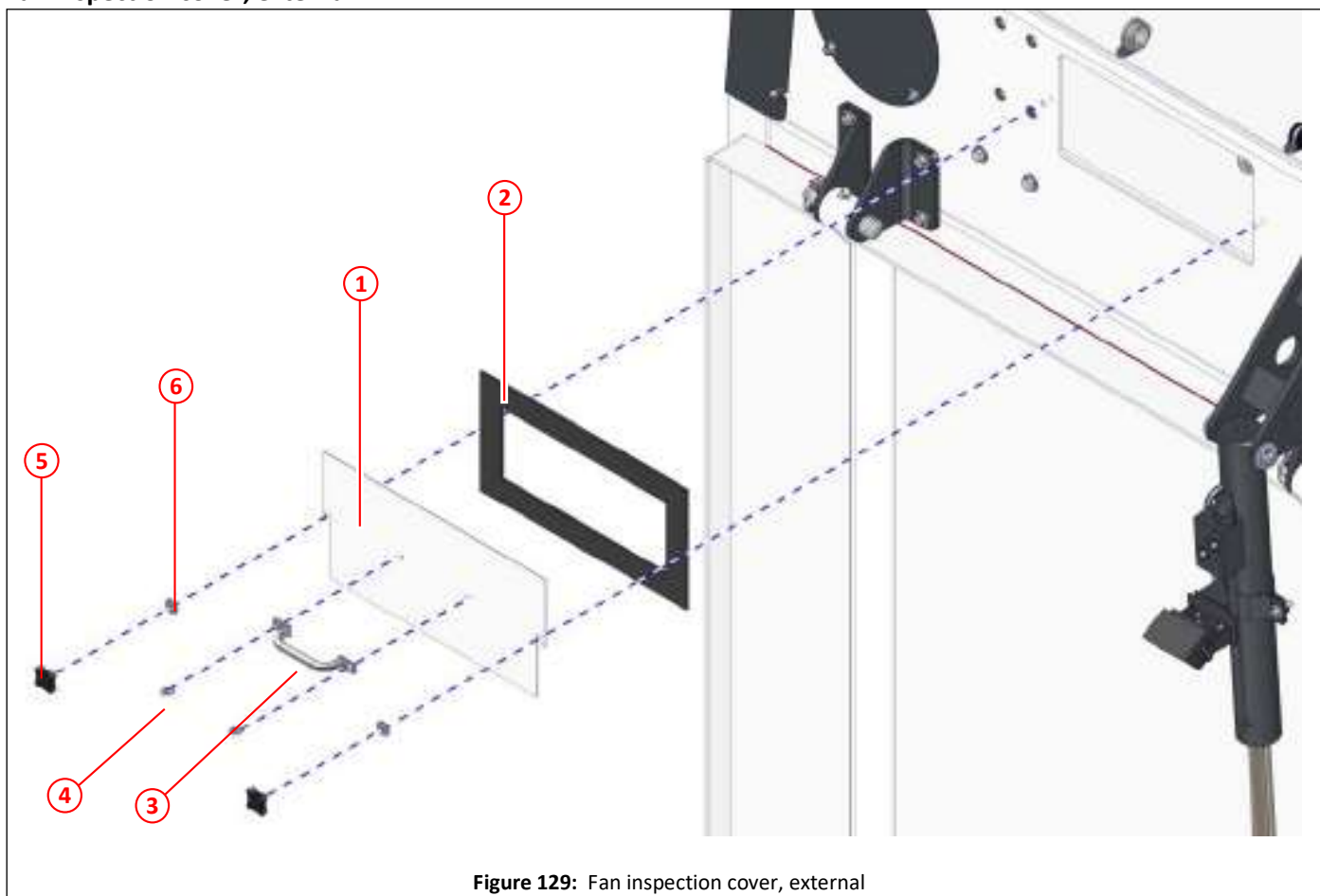

Figure 129: Fan inspection cover, external

Item	Part No	Qty	Description
①	030728	1	Cover, fan inspection, external
②	010546	As req	Seal strip 3 x 38
③	010502	1	Handle
④	011131	4	Rivet, blind $\varnothing$ 4.8 x 18
⑤	000248	2	Grip nut
⑥	000264	2	Plain washer M8, stainless steel



Fan inspection cover, internal

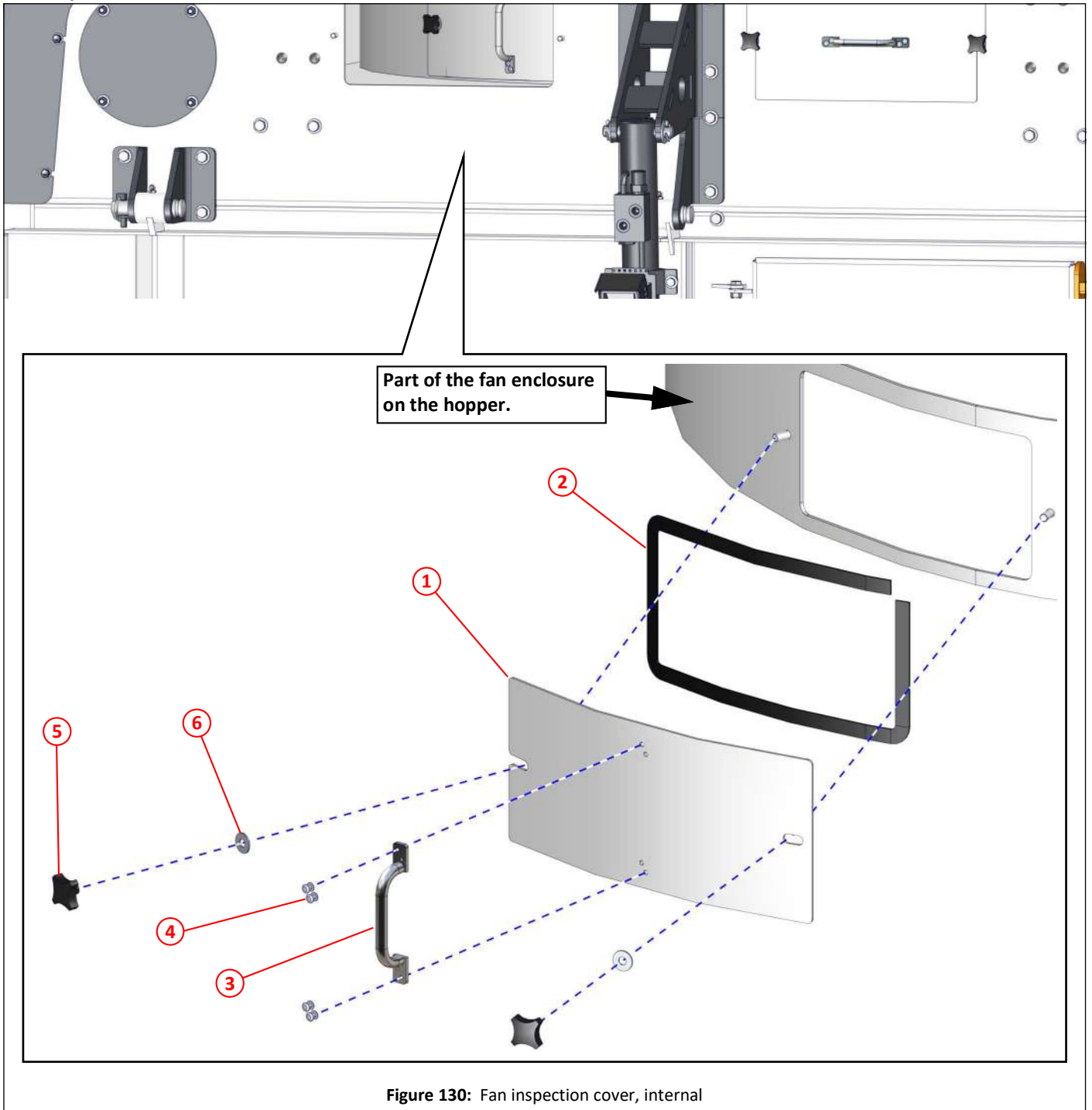

Figure 130: Fan inspection cover, internal

Item	Part No	Qty	Description
①	030730	1	Cover, fan inspection, internal
②	005020	As req	Seal strip 15 x 25
③	010502	1	Handle
④	011131	4	Rivet, blind $\varnothing 4.8 \times 18$
⑤	000248	2	Grip nut
⑥	000264	2	Plain washer M8, stainless steel

Fan inspection cover with wash assist, internal

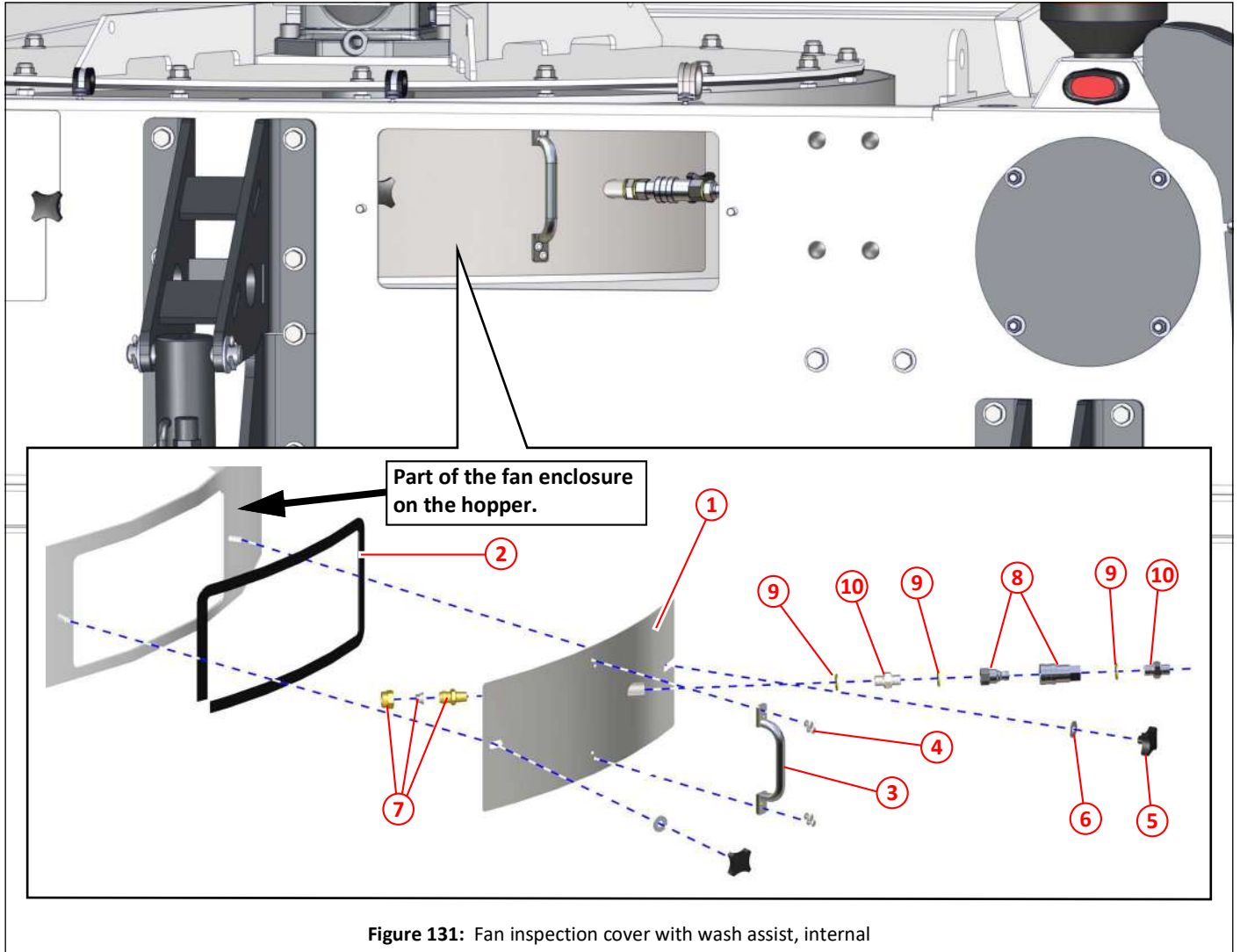

Figure 131: Fan inspection cover with wash assist, internal

Item	Part No	Qty	Description	
①	030731	1	Cover, fan cleaner, quick release	245
②	005020	As req	Seal strip 15 x 25	
③	010502	1	Handle	
④	011131	4	Rivet, blind $\varnothing 4.8 \times 18$	
⑤	000248	2	Grip nut	
⑥	000264	2	Plain washer M8, stainless steel	
⑦	030507	1	Spray jet assembly LF6-80	245
⑧	012985	1	Coupling, quick release, high pressure $\frac{1}{4}$ " BSP	
⑨	011152	3	Dowty seal $\frac{1}{4}$ " BSP	
⑩	011158	2	Adapter $\frac{1}{4}$ " BSP	

Locker door, right hand side

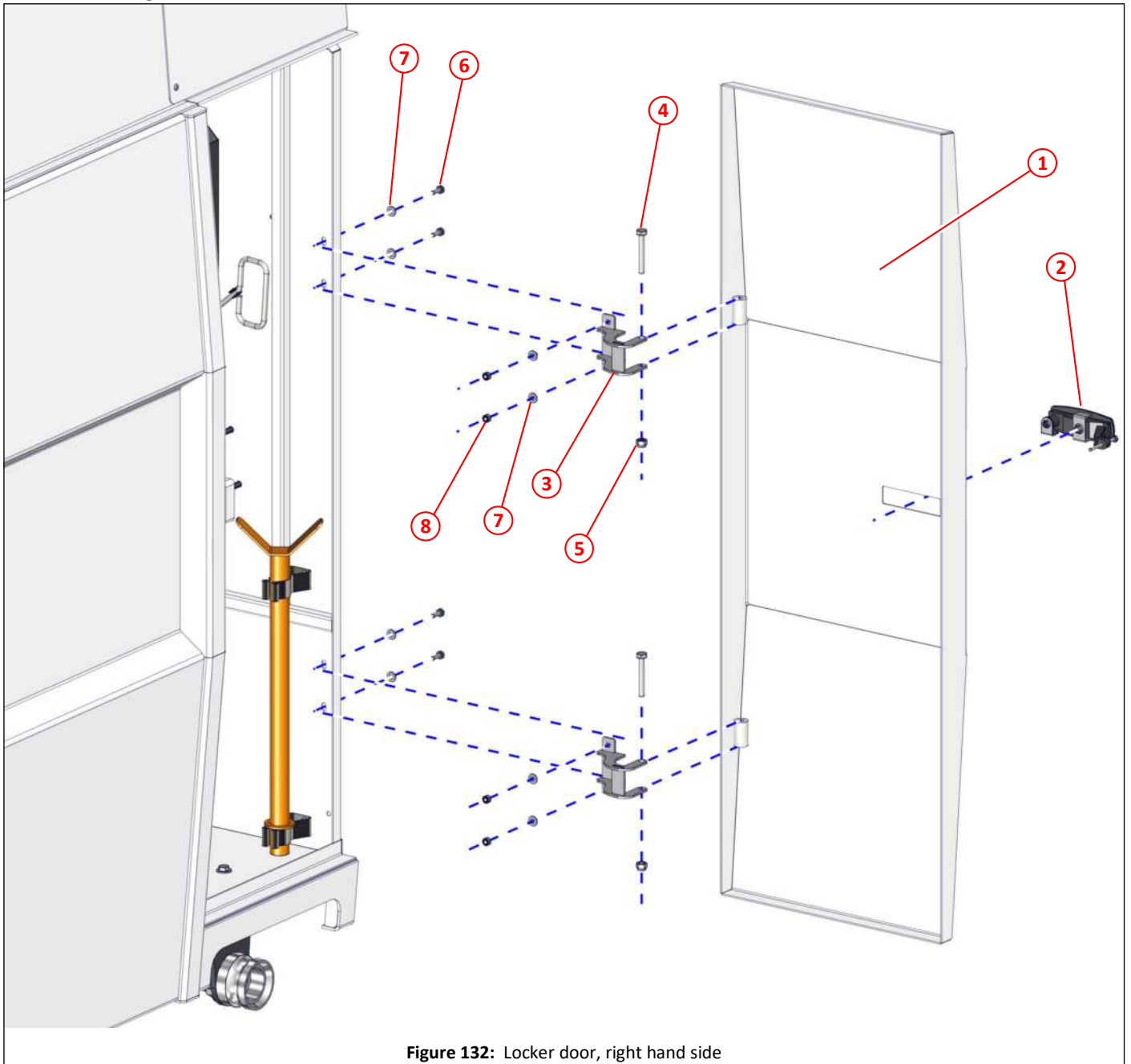

Figure 132: Locker door, right hand side

Item	Part No	Qty	Description
①	044691	1	Locker door, right hand side
②	033115	1	Latch, locking
③	034809	2	Hinge, locker door
④	000261	2	Bolt M8 x 55, stainless steel
⑤	000263	2	Nyloc nut M8, stainless steel
⑥	000250	4	Set screw M6 x 16, stainless steel
⑦	000254	8	Plain washer M6, stainless steel
⑧	000253	4	Nyloc nut M6, stainless steel

## Locker door, left hand side

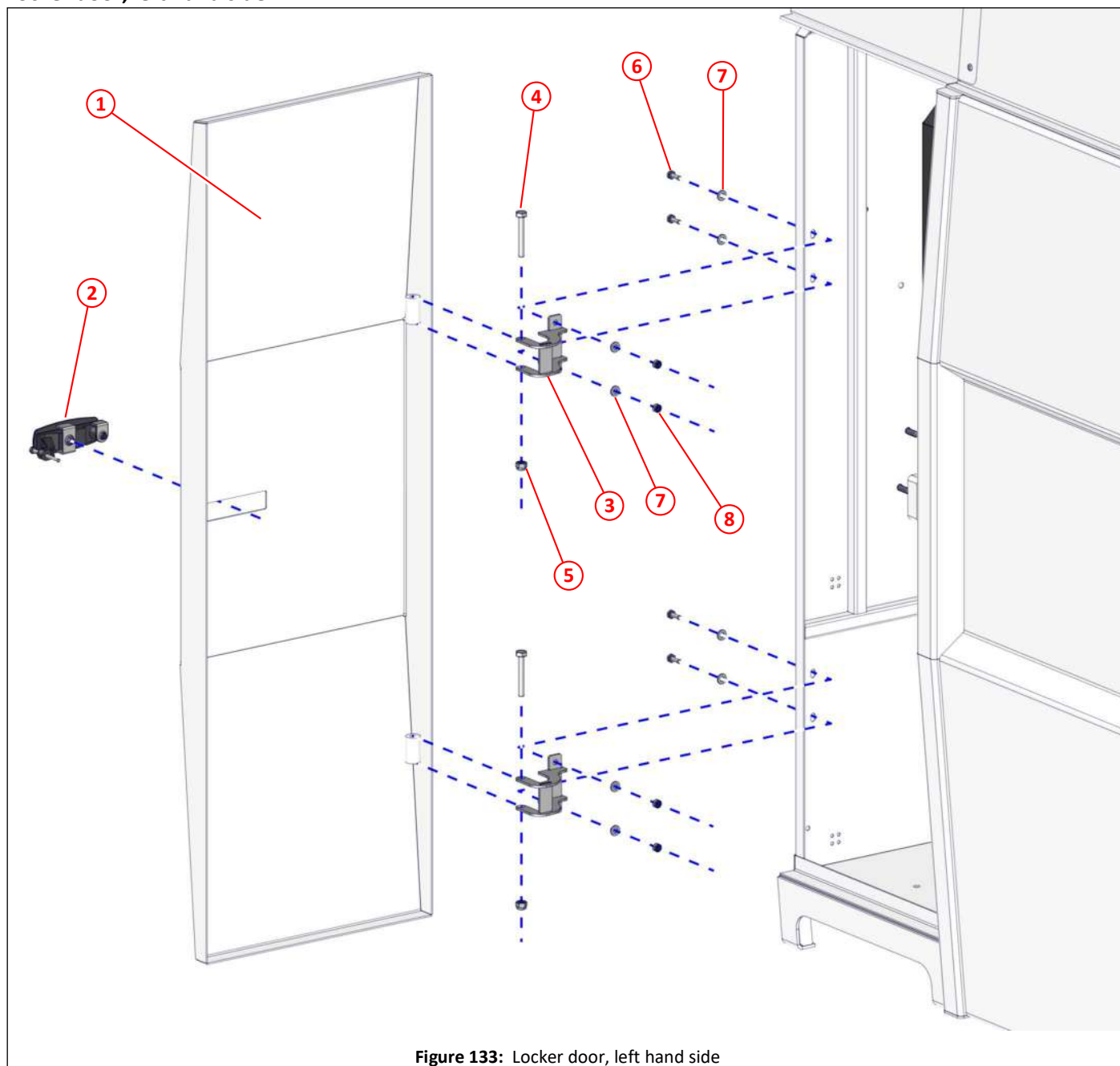

Figure 133: Locker door, left hand side

Item	Part No	Qty	Description
①	044690	1	Locker door, left hand side
②	033115	1	Latch, locking
③	034809	2	Hinge, locker door
④	000261	2	Bolt M8 x 55, stainless steel
⑤	000263	2	Nyloc nut M8, stainless steel
⑥	000250	4	Set screw M6 x 16, stainless steel
⑦	000254	8	Plain washer M6, stainless steel
⑧	000253	4	Nyloc nut M6, stainless steel

Hopper chutes

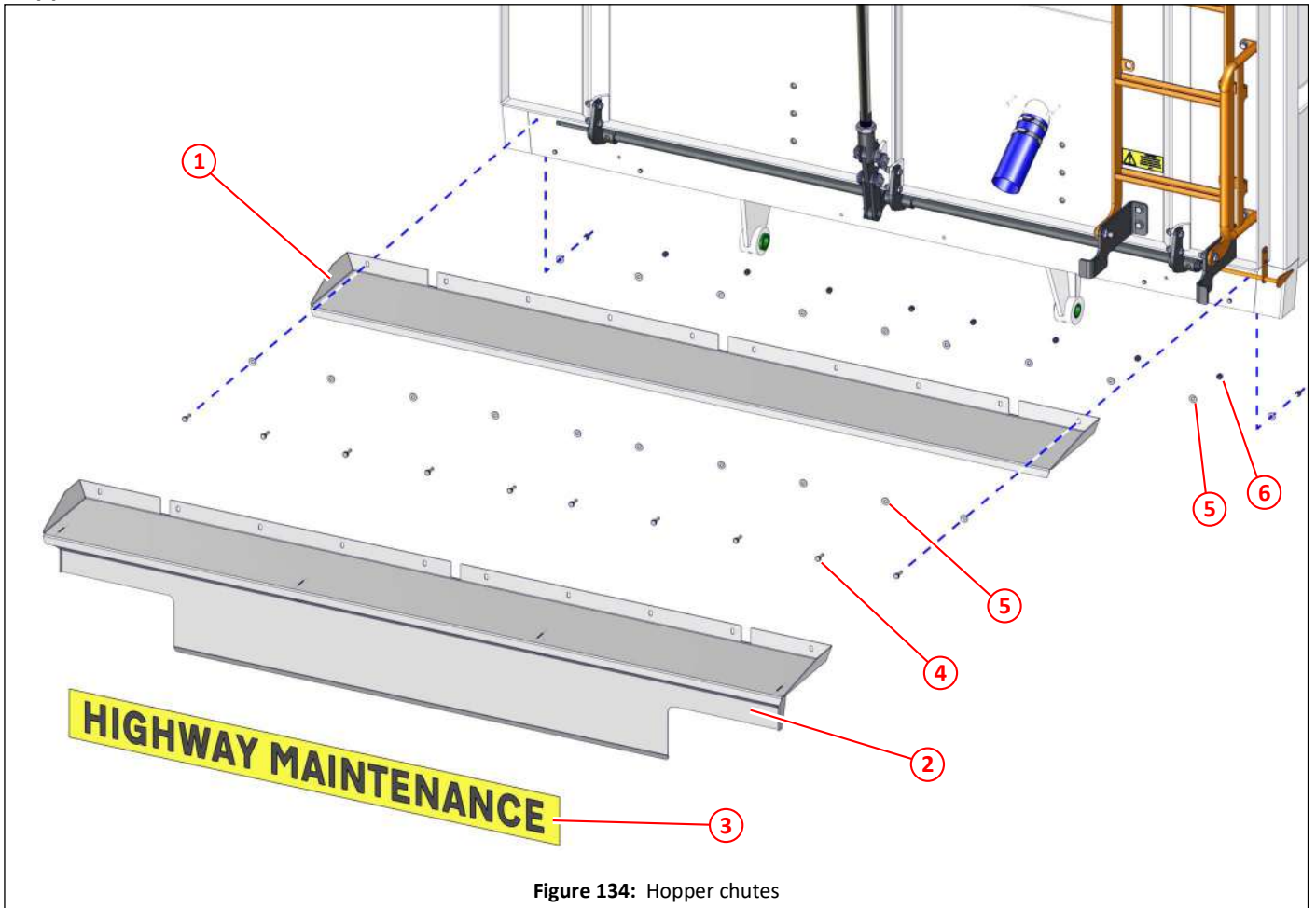

Figure 134: Hopper chutes

Item	Part No	Qty	Description
①	034337	1	Hopper chute
②	039431	1	Hopper chute, with conspicuity mounting
③	039370	1	Sign, 'HIGHWAY MAINTENANCE'
④	000257	10	Set screw M8 x 25, stainless steel
⑤	000264	20	Plain washer M8, stainless steel
⑥	000263	10	Nyloc nut M8, stainless steel

Pipework, hopper rear, left hand side

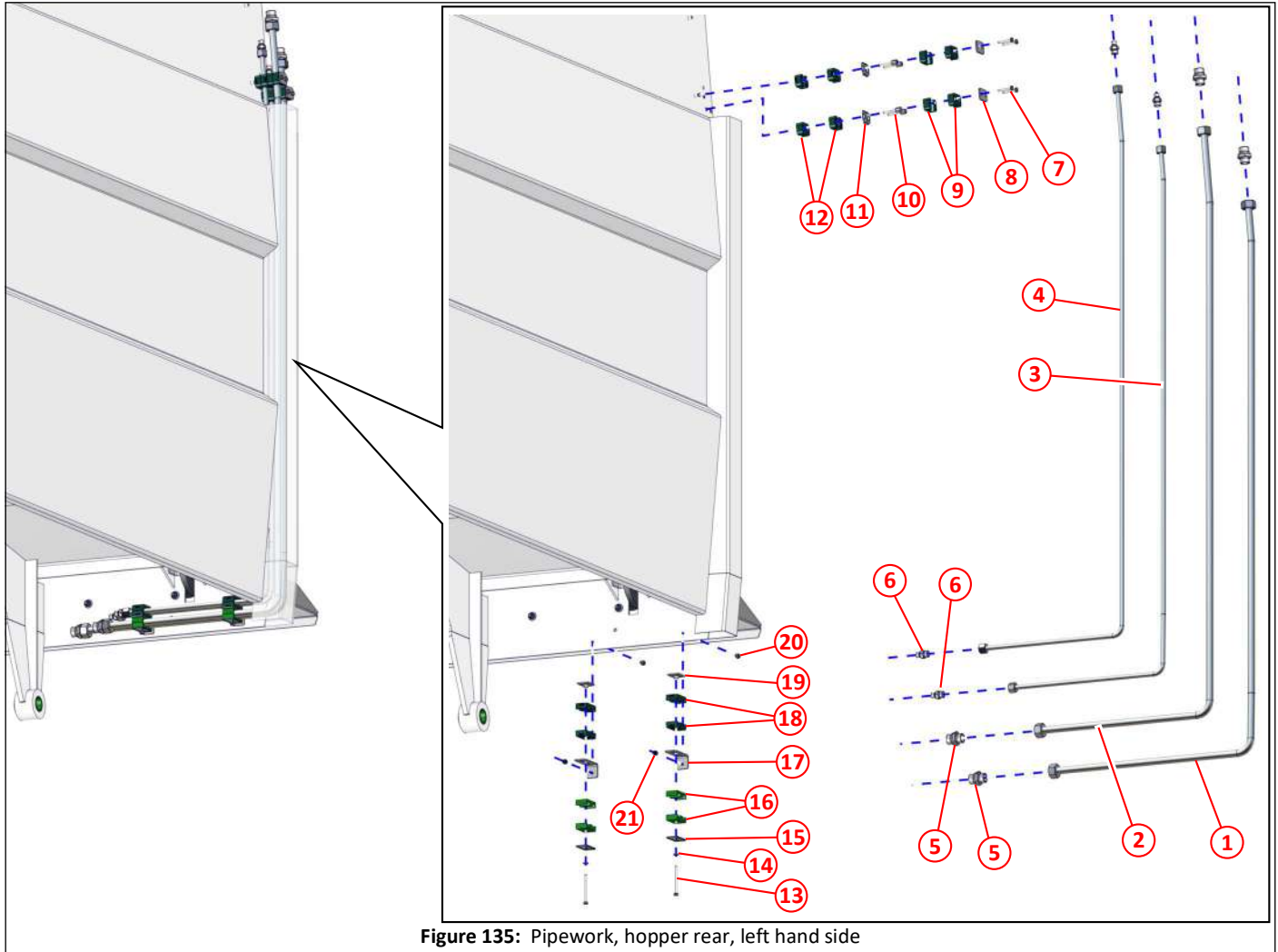

Figure 135: Pipework, hopper rear, left hand side

Item	Part No	Qty	Description
①	043603	1	Pipe, steel, suction fan return
②	043602	1	Pipe, steel, suction fan feed
③	043606	1	Pipe, steel, rear door close
④	043605	1	Pipe, steel, rear door open
⑤	002177	4	Adapter, compression, M/M, 18mm x $\frac{3}{4}$ " BSP
⑥	002086	4	Adapter 12 X $\frac{1}{4}$ " BSP
⑦	011068	4	Bolt M6 x 35
⑧	031317	2	Clamp plate, flat
⑨	042796	4	Clamp block, pipe, $\phi$ 18 single
⑩	000470	4	Bolt, stacking 35mm (AF4)
⑪	000472	4	Plate, locking. SIG1
⑫	043691	4	Clamp block, pipe, $\phi$ 12.7 single
⑬	011143	2	Set screw M6 x 70
⑭	011090	2	Plain washer M6
⑮	031319	2	Clamp plate, flat
⑯	027988	4	Clamp block, pipe, $\phi$ 18 x $\phi$ 18 double
⑰	026196	2	Bracket, anti-vibration
⑱	043590	4	Clamp block, pipe, $\phi$ 12.7 x $\phi$ 12.7 double
⑲	027993	2	Clamp plate, bottom
⑳	000250	2	Set screw M6 x 16, stainless steel
㉑	000253	2	Nyloc nut M6, stainless steel



## Pipework, hopper rear, right hand side

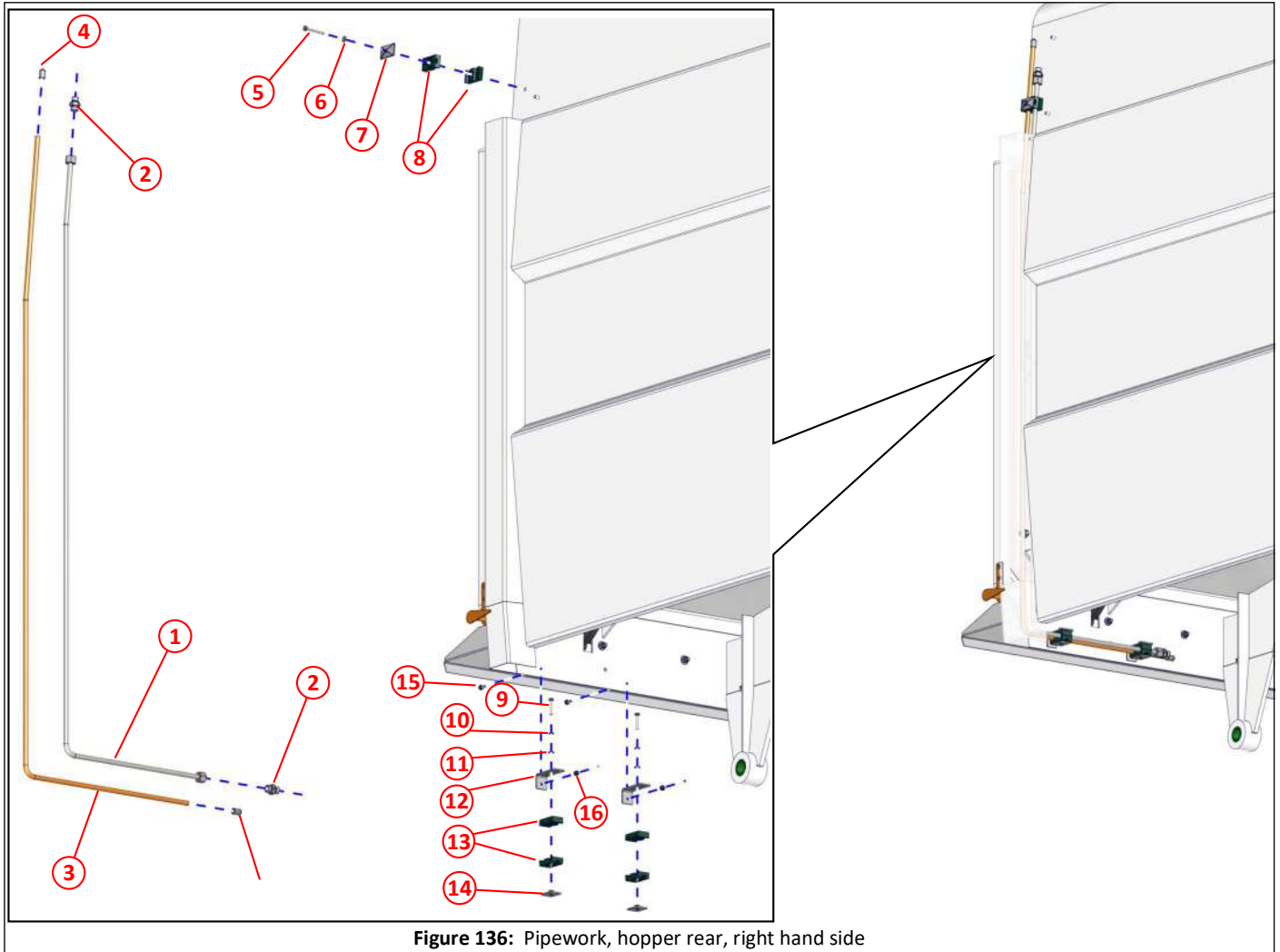

Figure 136: Pipework, hopper rear, right hand side

Item	Part No	Qty	Description
①	043604	1	Pipe, steel, suction fan case
②	020903	2	Adapter $\phi 12 \times \frac{3}{8}$ " BSP
③	043607	1	Loom rail, hopper
④	043065	2	Cap, pipe, $\phi 12$ OD
⑤	011003	1	Set screw M6 x 50
⑥	011090	1	Plain washer M6
⑦	031319	1	Clamp plate, flat
⑧	043590	2	Clamp block, pipe, $\phi 12.7 \times \phi 12.7$ double
⑨	011068	2	Bolt M6 x 35
⑩	011091	2	Spring washer M6
⑪	011090	2	Plain washer M6
⑫	026196	2	Bracket, anti-vibration
⑬	043590	4	Clamp block, pipe, $\phi 12.7 \times \phi 12.7$ double
⑭	027993	2	Clamp plate, bottom
⑮	000250	2	Set screw M6 x 16, stainless steel
⑯	000253	2	Nyloc nut M6, stainless steel

## Hopper and body arrangement, internal

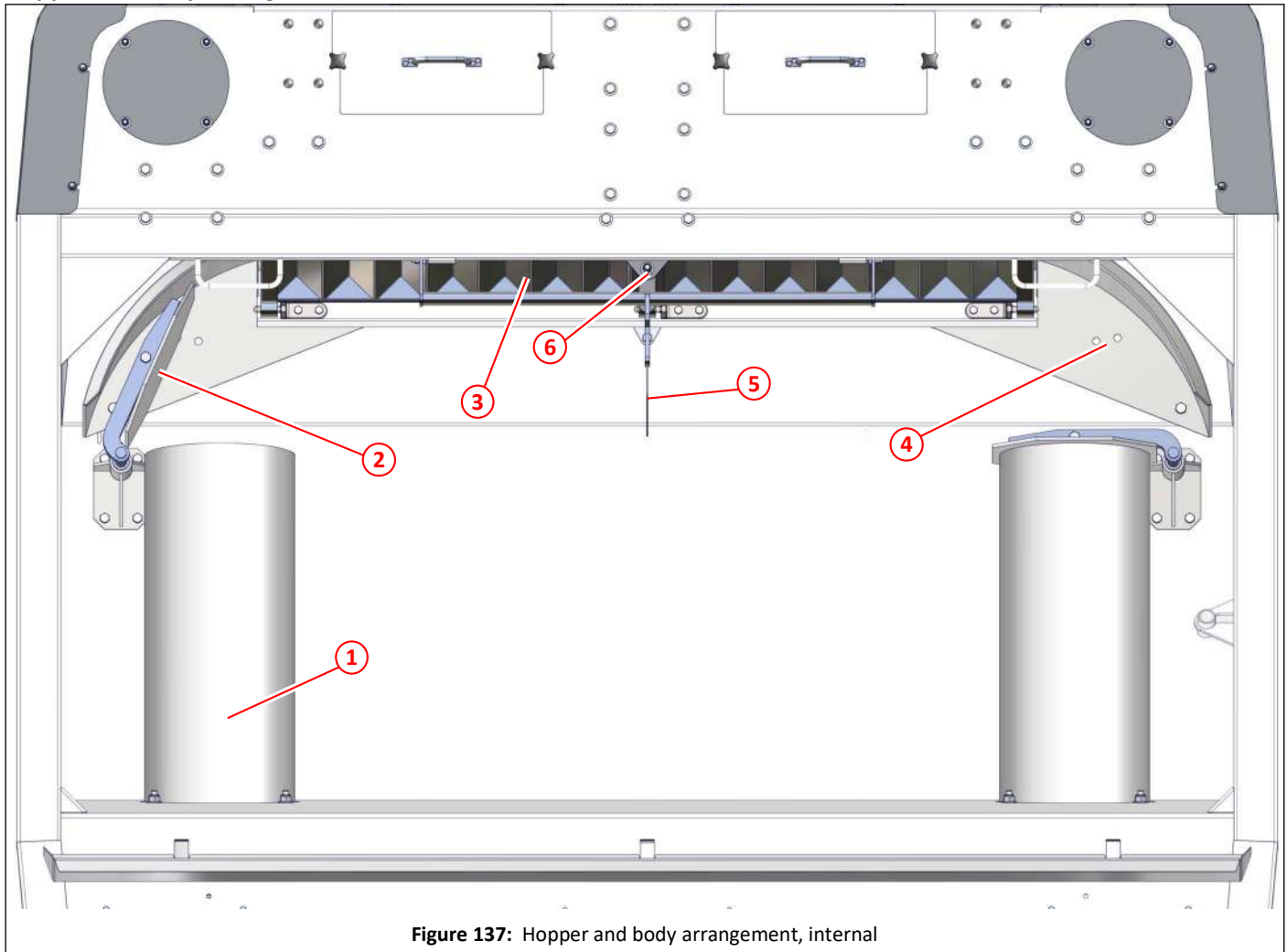

Figure 137: Hopper and body arrangement, internal

Item	Part No	Qty	Description	
①	044603	1	Tube, deflector	93,107
②			Auto blanking arrangement	96,113
③	031883	1	Screen, filter, suction fan, stainless steel	147,171,173
④	022644	2	Deflector	93,107
⑤	044618	1	Deflector flap	112
⑥			Safety latch, screen	171,172,173

Hopper and body arrangement, internal

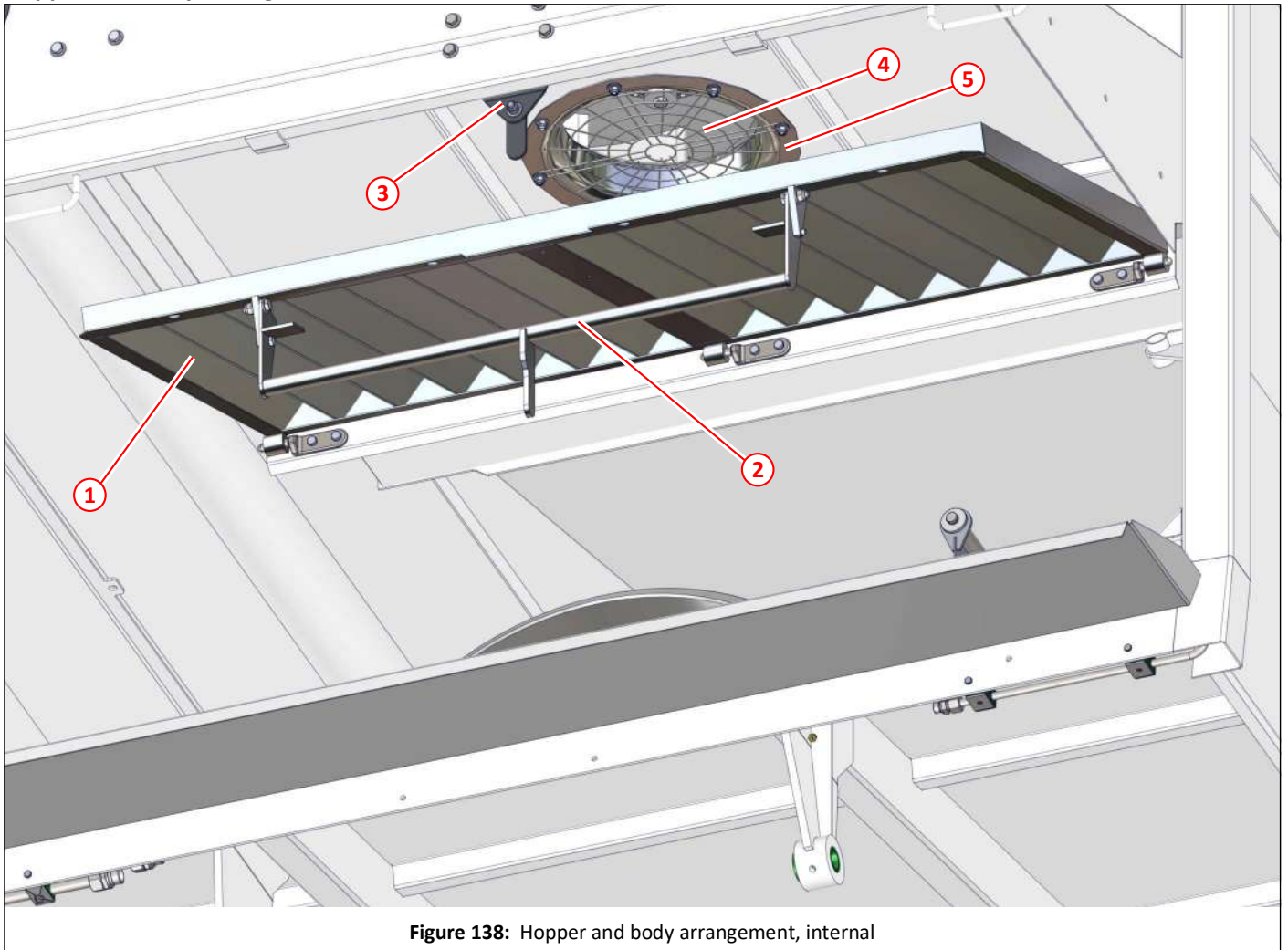

Figure 138: Hopper and body arrangement, internal

Item	Part No	Qty	Description	
①	031883	1	Screen, filter, suction fan, stainless steel	147,170,173
②	039312	1	Handle, screen latch, long handle	147,173
③			Safety latch, screen	170,172,173,174
④	039674		Guard, fan	146,172
⑤	032357		Cone, suction fan	146,172

## Suction fan inlet cone and guard

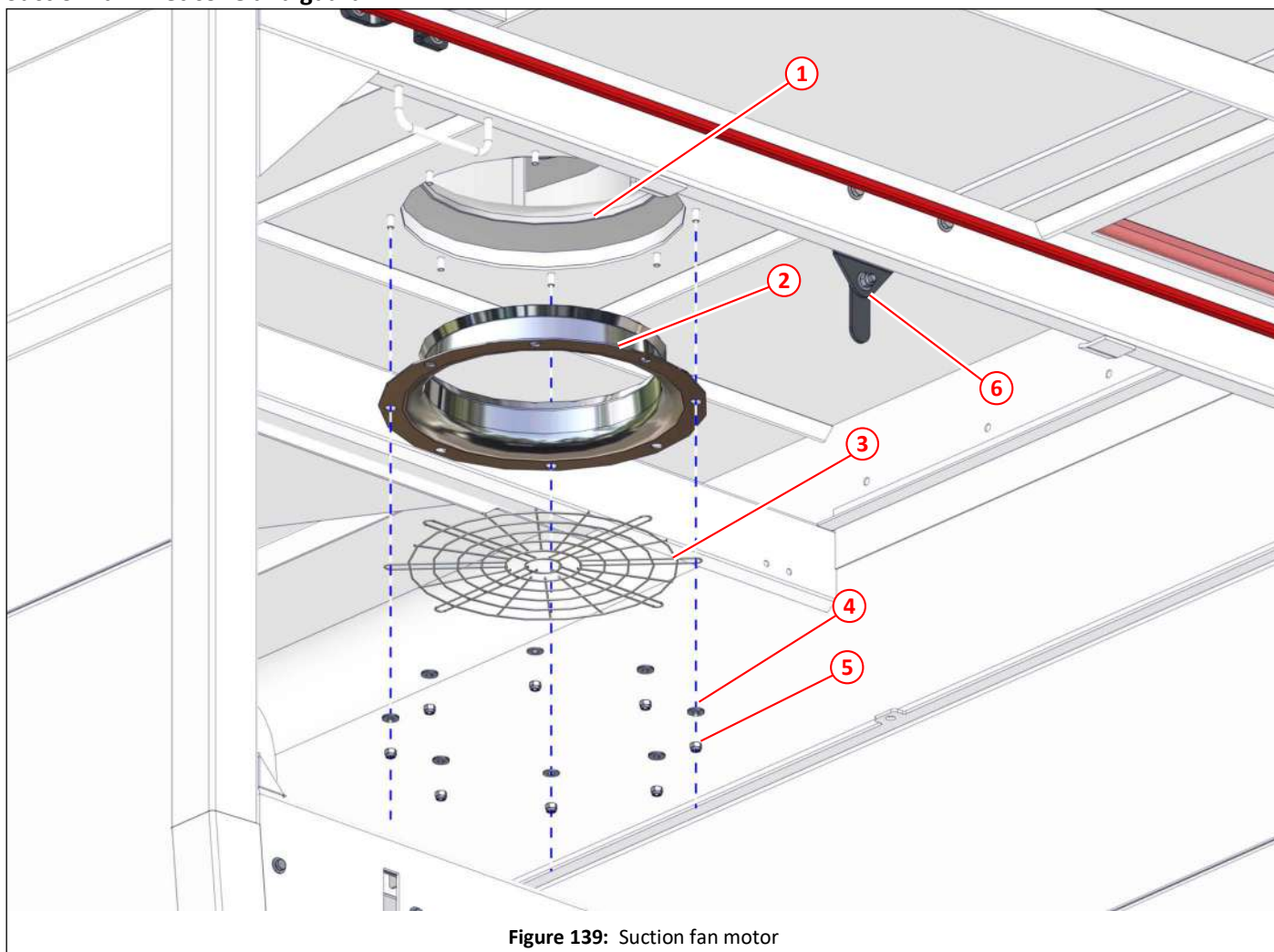

Figure 139: Suction fan motor

Item	Part No	Qty	Description	
①	030651	1	Impeller, stainless steel	144
②	032357	1	Inlet cone, stainless steel	146,171
③	039674	1	Guard, fan	146,171
④	000264	8	Plain washer, M8, stainless steel	
⑤	000263	8	Nyloc nut M8, stainless steel	
⑥			Safety latch, screen	174

Suction fan filter screen

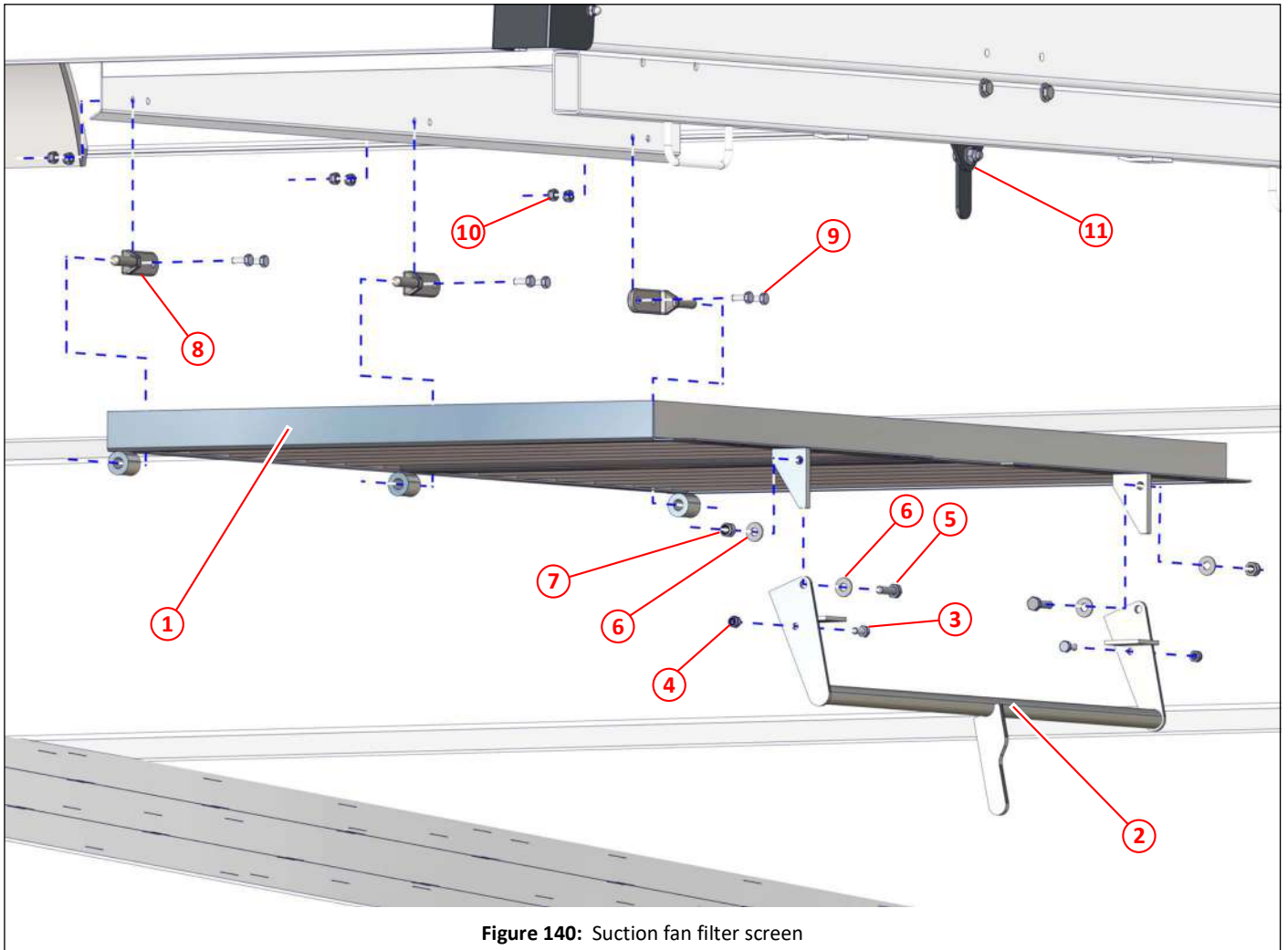

Figure 140: Suction fan filter screen

Item	Part No	Qty	Description	
①	031883	1	Screen, filter, suction fan, stainless steel	147,170,171
②	039312	1	Latch, long handle, screen	171
③	000256	2	Set screw M8 x 20, stainless steel	
④	000263	2	Nyloc nut, M8, stainless steel	
⑤	000462	2	Set screw M10 x 35, stainless steel	
⑥	011094	4	Plain washer M10	
⑦	011075	2	Nyloc nut M10	
⑧	025245	3	Gudgeon	
⑨	000256	6	Set screw M8 x 20, stainless steel	
⑩	000263	6	Nyloc nut, M8, stainless steel	
⑪			Safety latch, screen	174

## Safety latch, suction fan filter screen

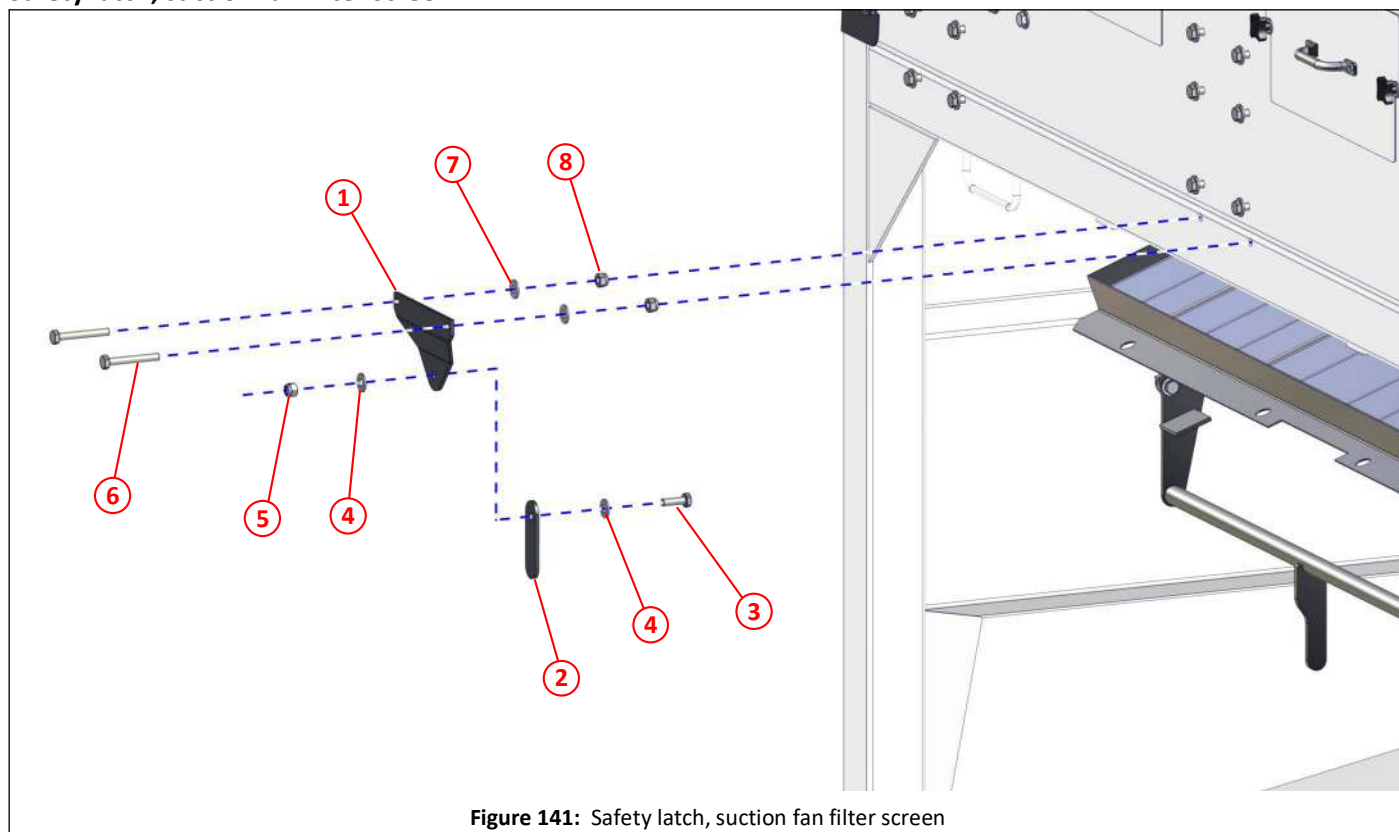

Figure 141: Safety latch, suction fan filter screen

Item	Part No	Qty	Description
①	028052	1	Safety bracket
②	028053	1	Safety link
③	000461	1	Set screw M10 x 30, stainless steel
④	000270	2	Plain washer M10, stainless steel
⑤	000269	1	Nyloc nut M10, stainless steel
⑥	011043	2	Bolt M10 x 70
⑦	011094	2	Plain washer M10
⑧	011075	2	Nyloc nut M10



Hopper blanking for single sweep

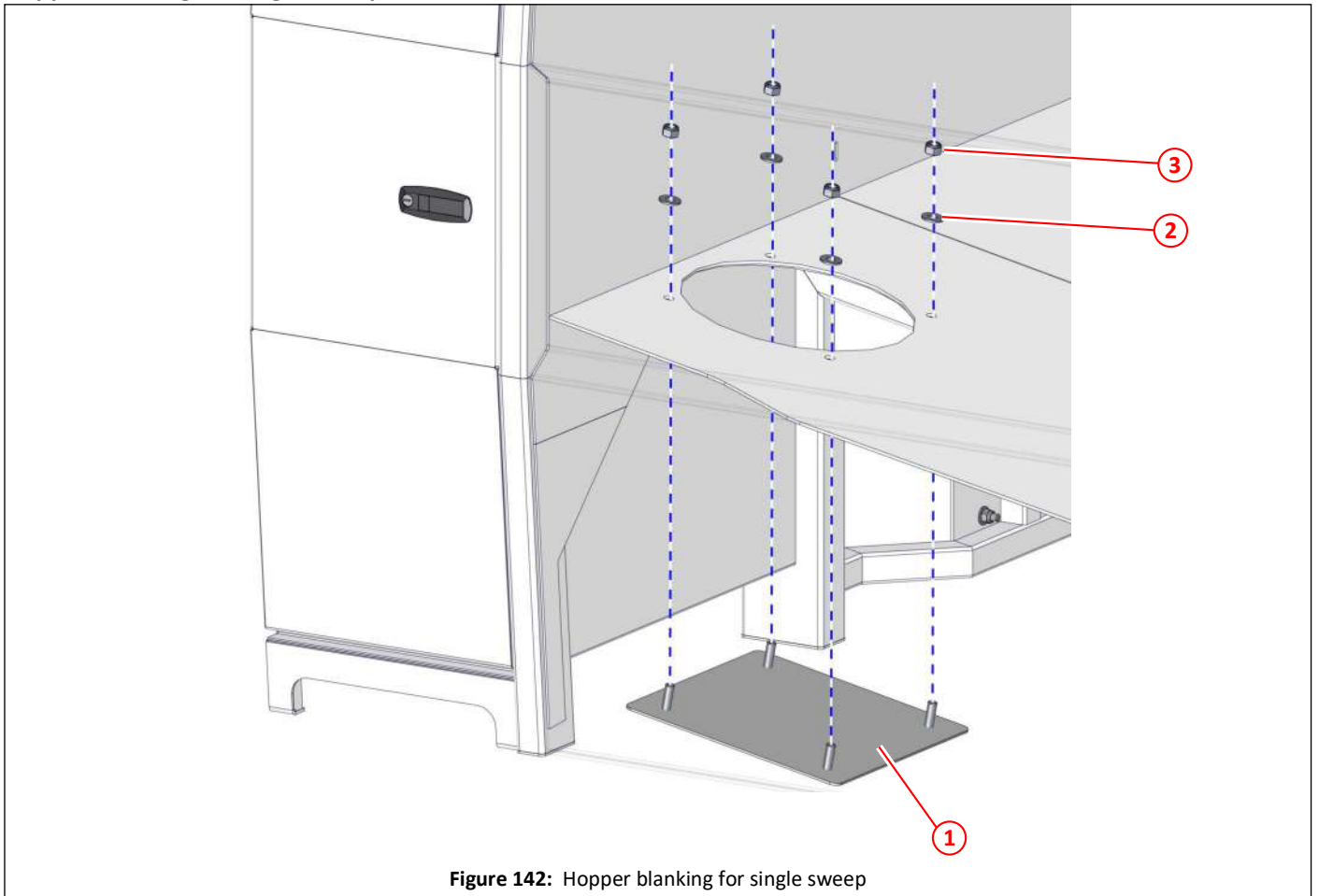
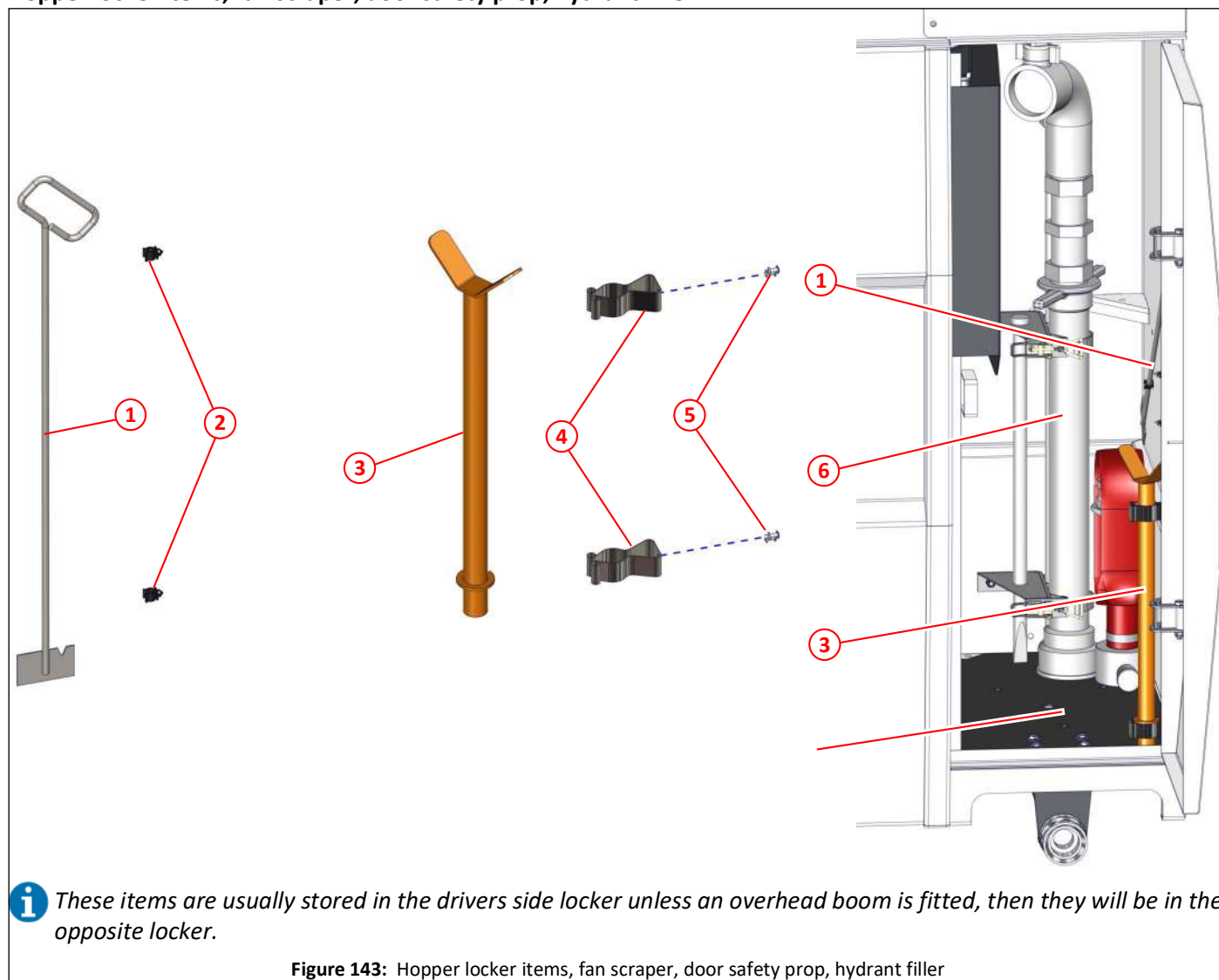

Figure 142: Hopper blanking for single sweep

Item	Part No	Qty	Description	
①	038725	1	Plate, deflector tube blanking	
②	000277	4	Plain washer M12, stainless steel	
③	000275	4	Nyloc nut M12, stainless steel	

## Hopper locker items, fan scraper, door safety prop, hydrant filler



Item	Part No	Qty	Description	
①	013514	1	Fan scraper	
②	013631	2	Clip, fir tree	
③	039683	1	Safety prop, hopper rear door	
④	014806	2	Clip, broom	
⑤	011131	4	Rivet, blind $\varnothing 4.8 \times 18$	
⑥	044150	2	Rubber mat (one for each locker)	
⑦			Hydrant filler	177

Hydrant filler fittings and mountings

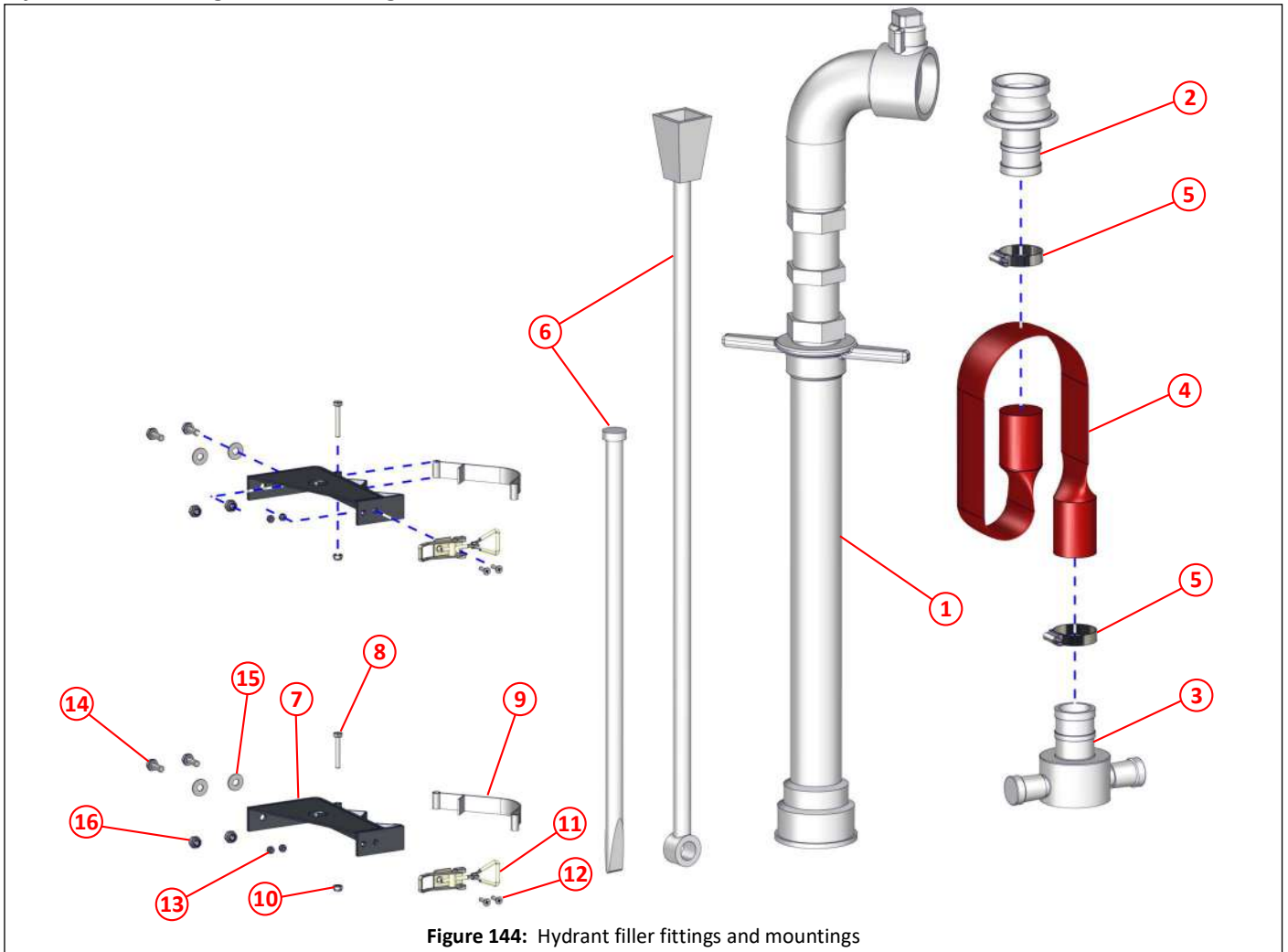
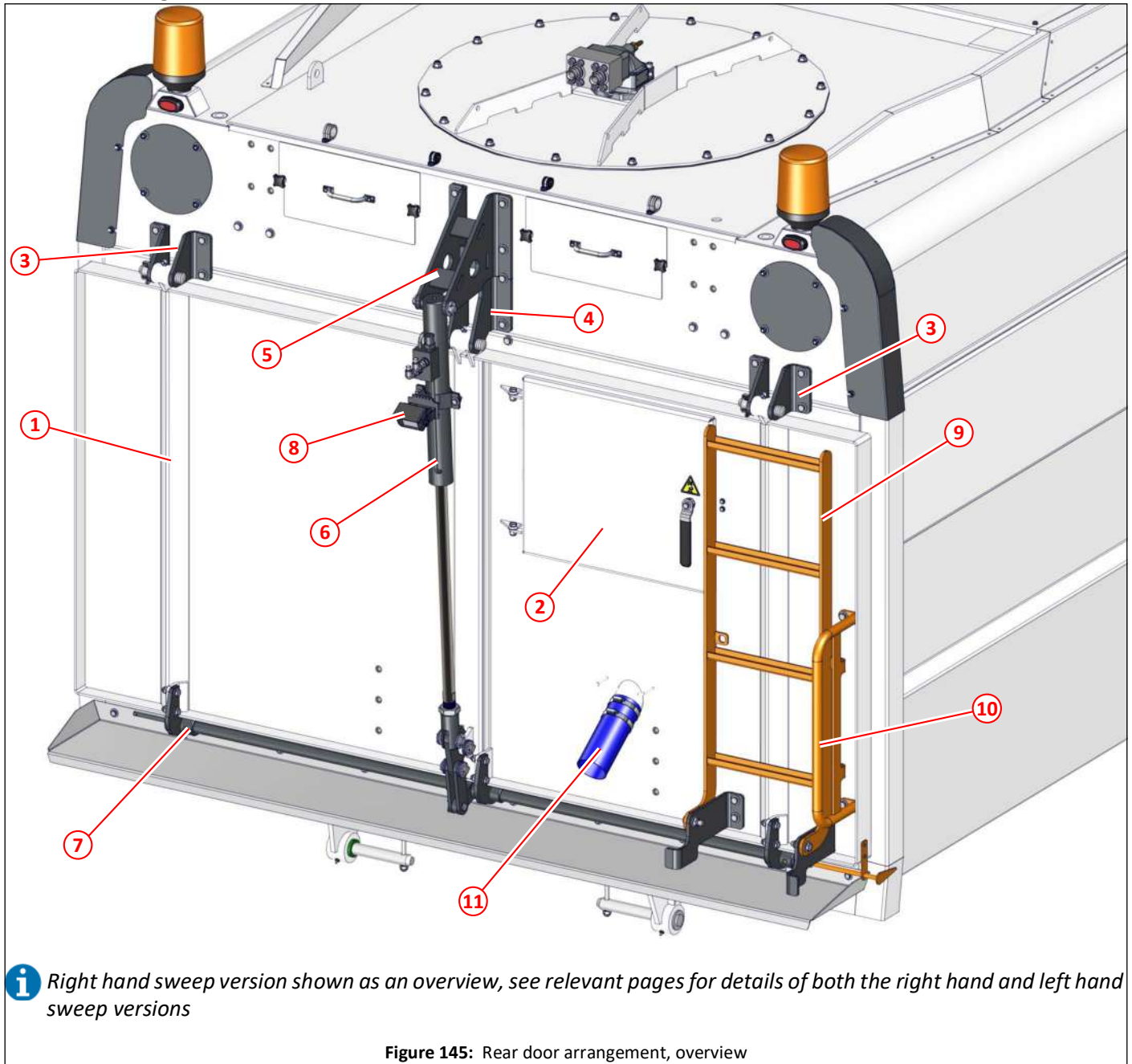

Figure 144: Hydrant filler fittings and mountings

Item	Part No	Qty	Description
①	014544	1	Hydrant standpipe
②	014546	1	Hydrant adapter, male, $\phi 2'' \times \phi 2.5''$
③	013171	1	Hydrant adapter hose tail
④	014547	4m	Hydrant lay flat hose
⑤	012927	2	Hose clamp, worm drive, No. 2 ( $\phi 40\text{mm}-\phi 55\text{mm}$ )
⑥	014545	1	Hydrant key and bar
⑦	020484*	1	Bracket, standpipe mounting
⑧	000021*	1	Set screw M6 x 40
⑨	020483*	1	Strap, standpipe mounting
⑩	011071*	1	Nyloc nut M6
⑪	010509*	1	OJOP fastener, with hinged toggle
⑫	000389*	2	Countersunk, Pozidrive head, screw M5 x 16, zinc and clear plated
⑬	000155*	2	Nyloc nut M5
⑭	011010*	2	Set screw M8 x 20
⑮	011092*	2	Plain washer M8
⑯	011073*	2	Nyloc nut M8

\*. Items are for 1 complete mounting bracket. Two brackets are required.

## Rear door arrangement, overview



Item	Part No	Qty	Description	
①		1	Rear door, with inspection/access hatch	179,180
②	036363	1	Hatch, inspection access	182,183
③		2	Hinge, door, outer	181
④		1	Hinge, door, inner	181
⑤		1	Hinge, ram door open/close/locking	187,188
⑥		1	Ram, door open/close/locking	187,189
⑦		1	Locking bar	187,190
⑧			Rear camera	189,193,329
⑨		1	Ladder, access	184,185
⑩		1	Grab rail	184,185
⑪			Hose, hopper drain	186

Rear door, with right hand inspection/access hatch

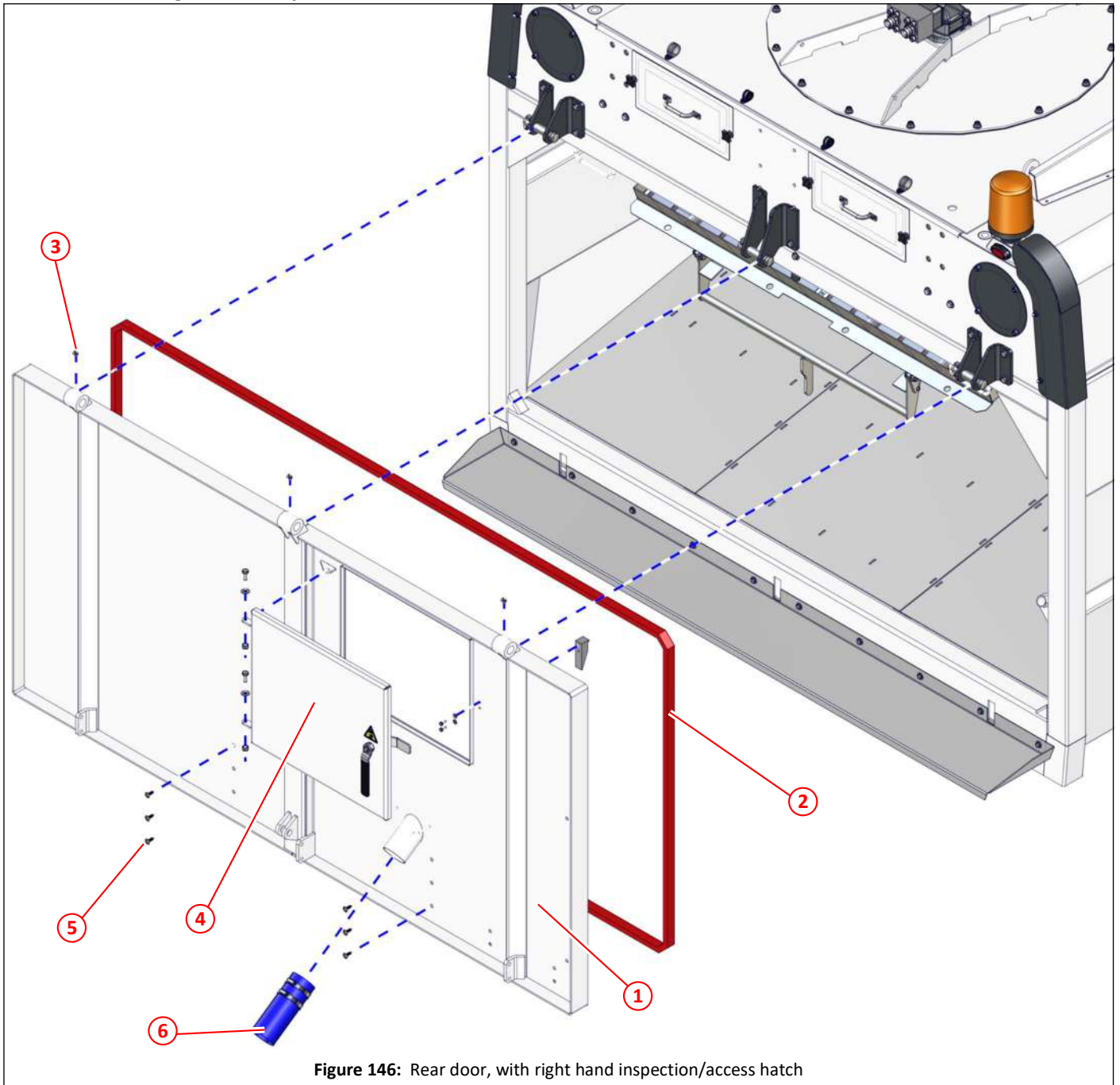

Figure 146: Rear door, with right hand inspection/access hatch

Item	Part No	Qty	Description	
①	039263	1	Door, rear, with right hand inspection/access hatch	
②	030806	1	Seal, rear door	
③	010902	3	Grease nipple $\frac{1}{8}$ " BSP, 90°	
④	036363	1	Hatch, inspection access	182,183
⑤	014563	6	Button, fir tree, used if no rear wander boom	
⑥			Hose, hopper drain	186



## Rear door, with left hand inspection/access hatch

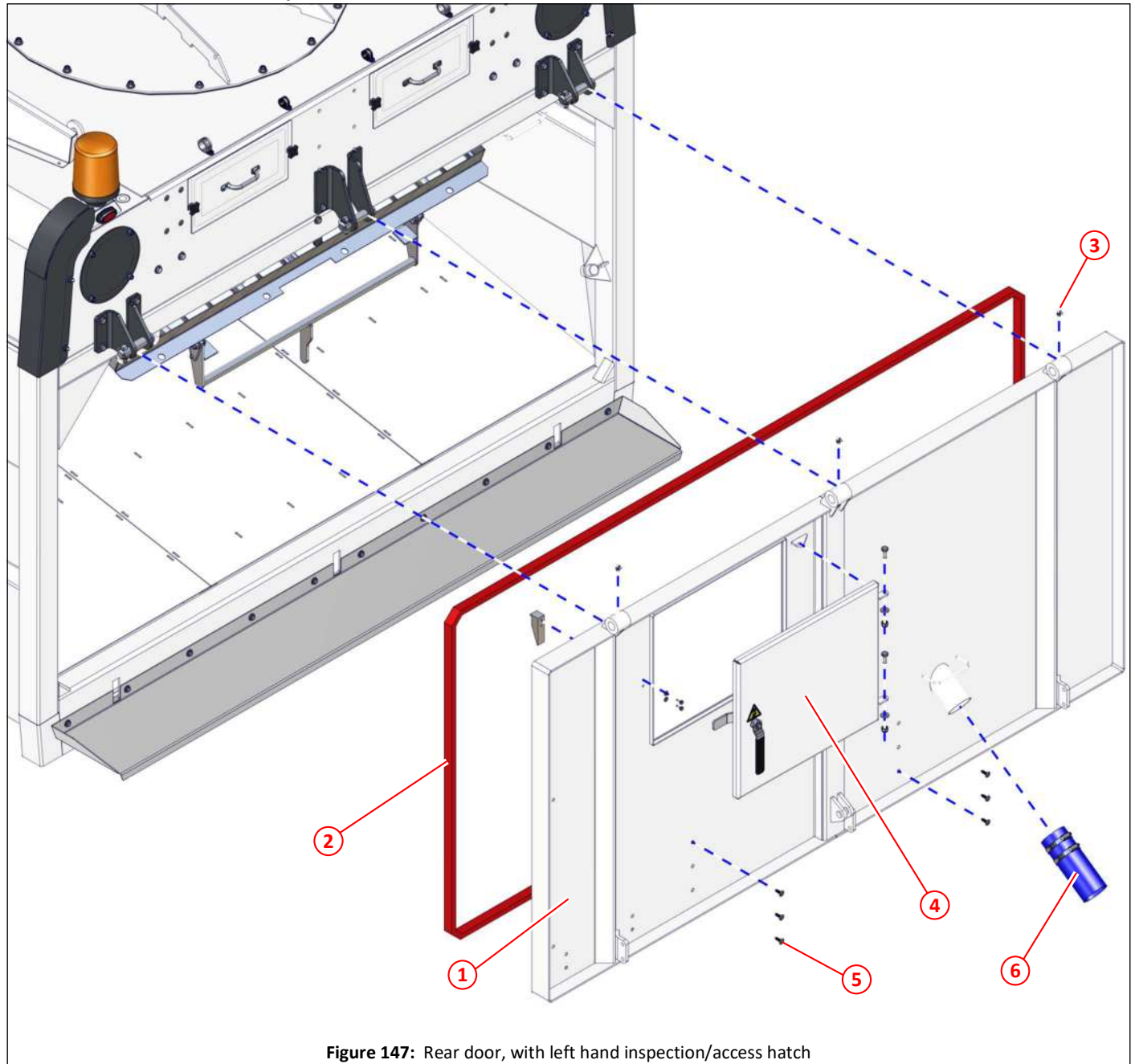

Figure 147: Rear door, with left hand inspection/access hatch

Item	Part No	Qty	Description	
①	039311	1	Door, rear, with left hand inspection/access hatch	
②	030806	1	Seal, rear door	
③	010902	3	Grease nipple $\frac{1}{8}$ " BSP, 90°	
④	036363	1	Hatch, inspection access	182,183
⑤	014563	6	Button, fir tree, used if no rear wander boom	
⑥			Hose, hopper drain	186



Hinges, rear door

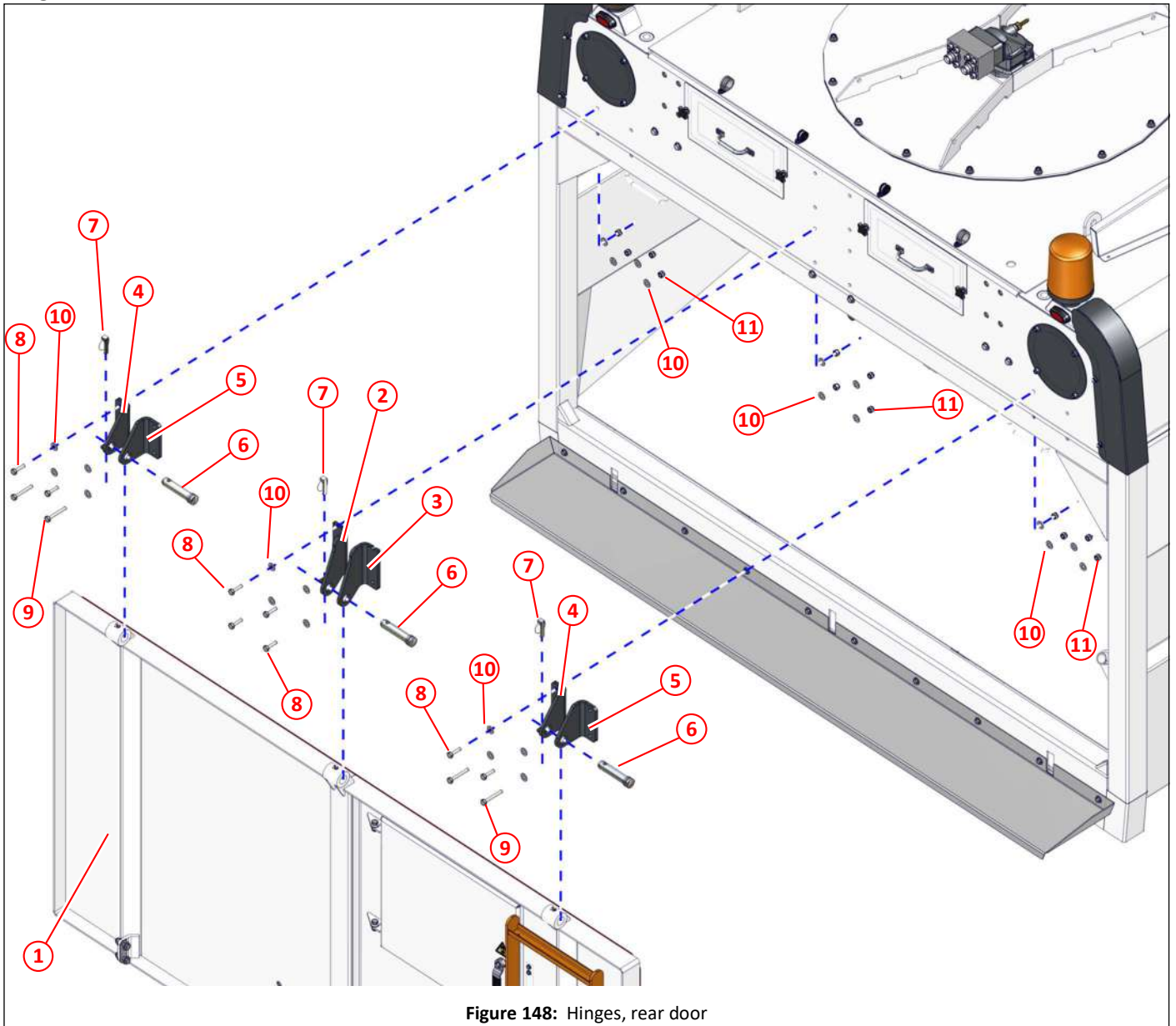

Figure 148: Hinges, rear door

Item	Part No	Qty	Description	
①		1	Rear door, with inspection/access hatch	179,180
②	035709	1	Hinge, rear door, centre left hand	
③	035710	1	Hinge, rear door, centre right hand	
④	034310	2	Hinge, rear door, outer left hand	
⑤	034311	2	Hinge, rear door, outer right hand	
⑥	013051	3	Pin, hinge	
⑦	013053	3	Lynch pin	
⑧	011033	8	Set screw M10 x 35	
⑨	011037	4	Bolt M10 x 65	
⑩	011094	24	Plain washer M10	
⑪	011075	12	Nyloc nut M10	

Inspection/access hatch, right hand

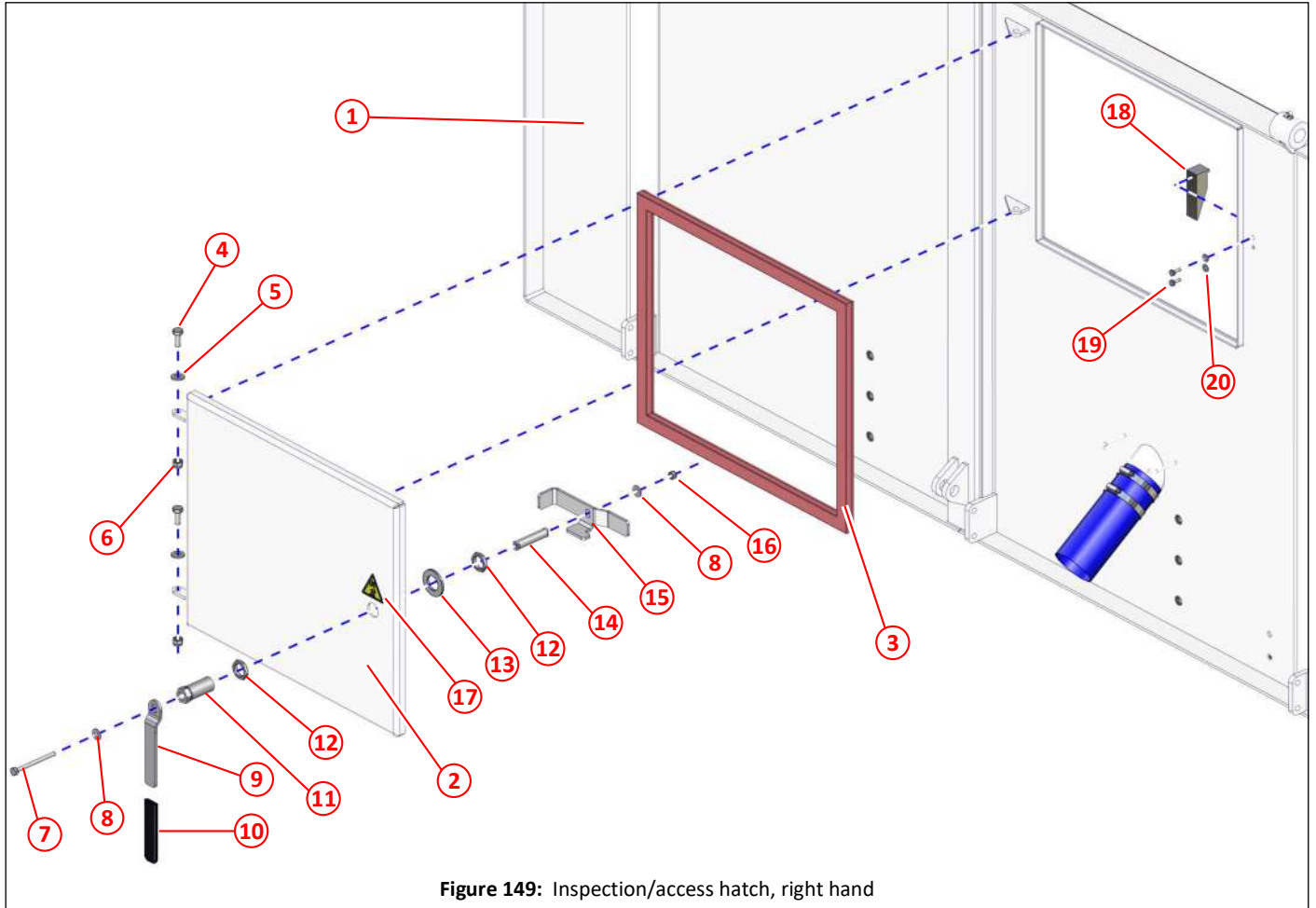

Figure 149: Inspection/access hatch, right hand

Item	Part No	Qty	Description	
①	039263	1	Door, rear, with right hand inspection/access hatch	179
②	036363	1	Hatch, inspection access	
③	013599	1	Seal, inspection/access hatch	
④	011031	2	Set screw M10 x 25	
⑤	011094	2	Plain washer M10	
⑥	011075	2	Nyloc nut M10	
⑦	011019	1	Bolt M8 x 90	
⑧	011092	2	Plain washer M8	
⑨	027933	1	Handle, door	
⑩	040032	1	Sleeve, door handle	
⑪	027935	1	Bearing, door catch	
⑫	027937	2	Back nut $\frac{3}{4}$ " BSP	
⑬	000121	1	Plain washer M27	
⑭	027934	1	Spindle, door catch	
⑮	040033	1	Door catch, with stop, for right hand inspection/access hatch	
⑯	011073	1	Nyloc nut M8	
⑰	039550	1	Label - Warning, debris	452
⑱	027932	1	Striker, door catch	
⑲	000250	2	Set screw M6 x 16, stainless steel	
⑳	000254	2	Plain washer M6, stainless steel	

Inspection/access hatch, left hand

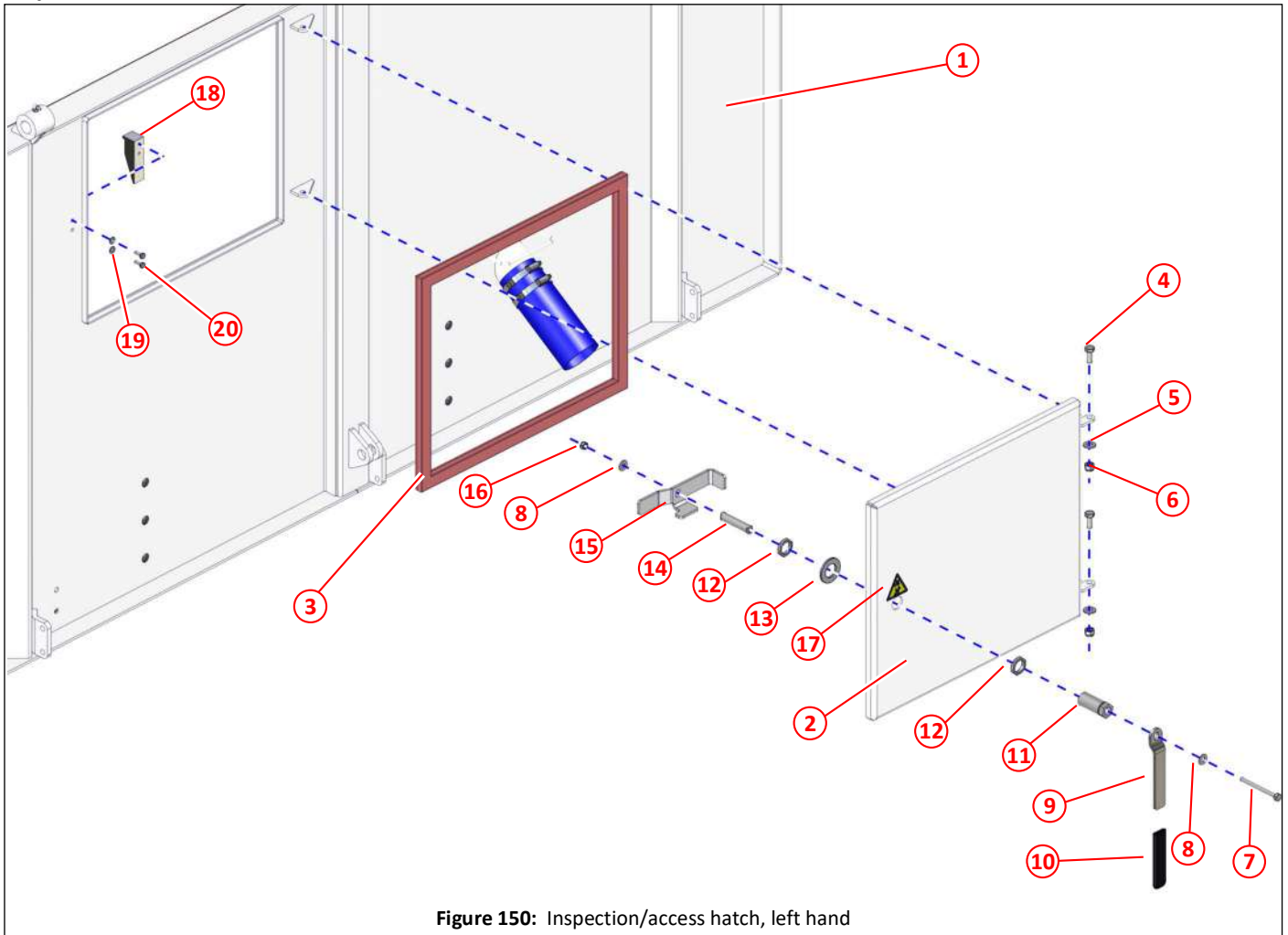

Figure 150: Inspection/access hatch, left hand

Item	Part No	Qty	Description	
①	039311	1	Door, rear, with left hand inspection/access hatch	180
②	036363	1	Hatch, inspection access	
③	013599	1	Seal, inspection/access hatch	
④	011031	2	Set screw M10 x 25	
⑤	011094	2	Plain washer M10	
⑥	011075	2	Nyloc nut M10	
⑦	011019	1	Bolt M8 x 90	
⑧	011092	2	Plain washer M8	
⑨	027933	1	Handle, door	
⑩	040032	1	Sleeve, door handle	
⑪	027935	1	Bearing, door catch	
⑫	027937	2	Back nut $\frac{3}{4}$ " BSP	
⑬	000121	1	Plain washer M27	
⑭	027934	1	Spindle, door catch	
⑮	040034	1	Door catch, with stop, for left hand inspection/access hatch	
⑯	011073	1	Nyloc nut M8	
⑰	039550	1	Label - Warning, debris	452
⑱	027932	1	Striker, door catch	
⑲	000250	2	Set screw M6 x 16, stainless steel	
⑳	000254	2	Plain washer M6, stainless steel	

Ladder and grab rail, rear door, right hand side

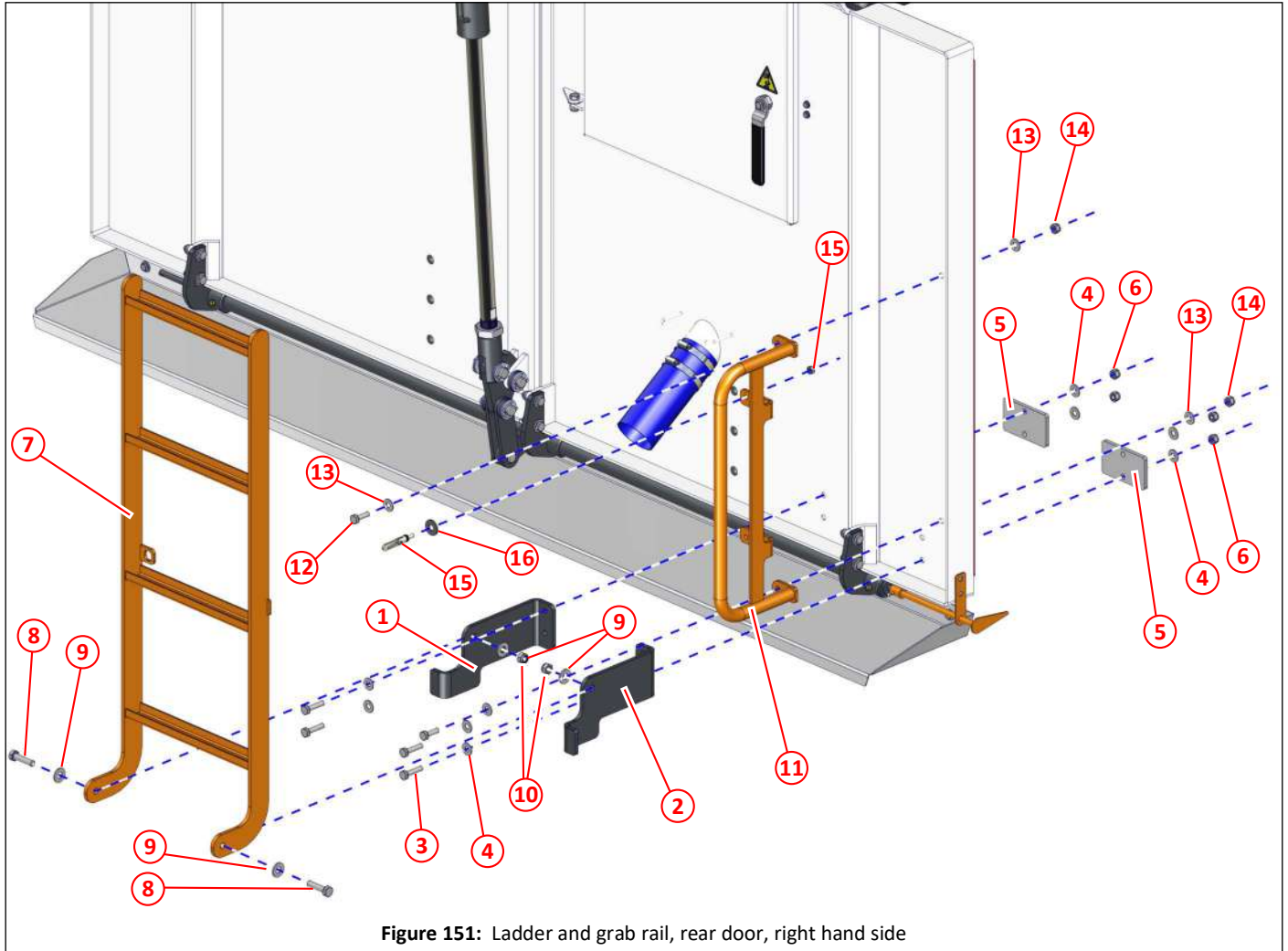

Figure 151: Ladder and grab rail, rear door, right hand side

Item	Part No	Qty	Description
①	039285	1	Hinge, rear ladder, left hand
②	039286	1	Hinge, rear ladder, right side
③	011034	4	Set screw M10 x 40
④	011094	8	Plain washer M10
⑤	040133	2	Plate, load spreader, rear ladder
⑥	011075	4	Nyloc nut M10
⑦	039284	1	Ladder, rear
⑧	011054	2	Set screw M12 x 45
⑨	011096	4	Plain washer M12
⑩	011077	2	Nyloc nut M12
⑪	039287	1	Grab handle, rear door
⑫	011032	2	Set screw M10 x 30
⑬	011094	4	Plain washer M10
⑭	011075	2	Nyloc nut M10
⑮	012253	1	Antiluce, small, includes star washer and nut
⑯	021979	1	Washer, sealing, rubber $\phi$ 12 x $\phi$ 30 x 3

## Ladder and grab rail, rear door, left hand side

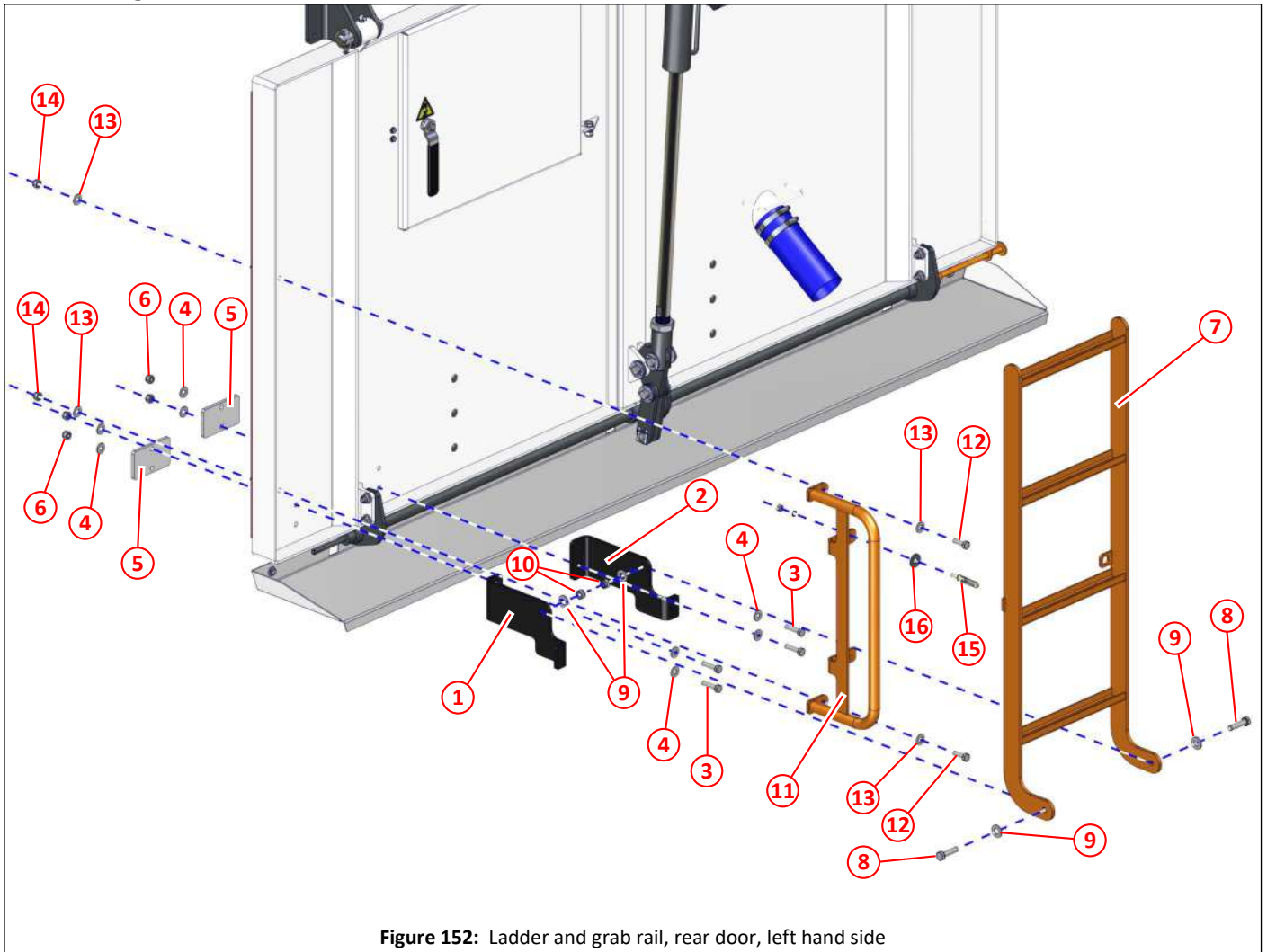

Figure 152: Ladder and grab rail, rear door, left hand side

Item	Part No	Qty	Description
①	039285	1	Hinge left hand, rear ladder
②	039286	1	Hinge right hand, rear ladder
③	011034	4	Set screw M10 x 40
④	011094	8	Plain washer M10
⑤	040133	2	Plate, load spreader, rear ladder
⑥	011075	4	Nyloc nut M10
⑦	039284	1	Ladder, rear
⑧	011054	2	Set screw M12 x 45
⑨	011096	4	Plain washer M12
⑩	011077	2	Nyloc nut M12
⑪	039287	1	Grab handle, rear door
⑫	011032	2	Set screw M10 x 30
⑬	011094	4	Plain washer M10
⑭	011075	2	Nyloc nut M10
⑮	012253	1	Antiluce, small, includes, star washer and nut
⑯	021979	1	Washer, sealing, rubber $\phi 12 \times \phi 30 \times 3$



## Lay flat hose, rear door, hopper drain

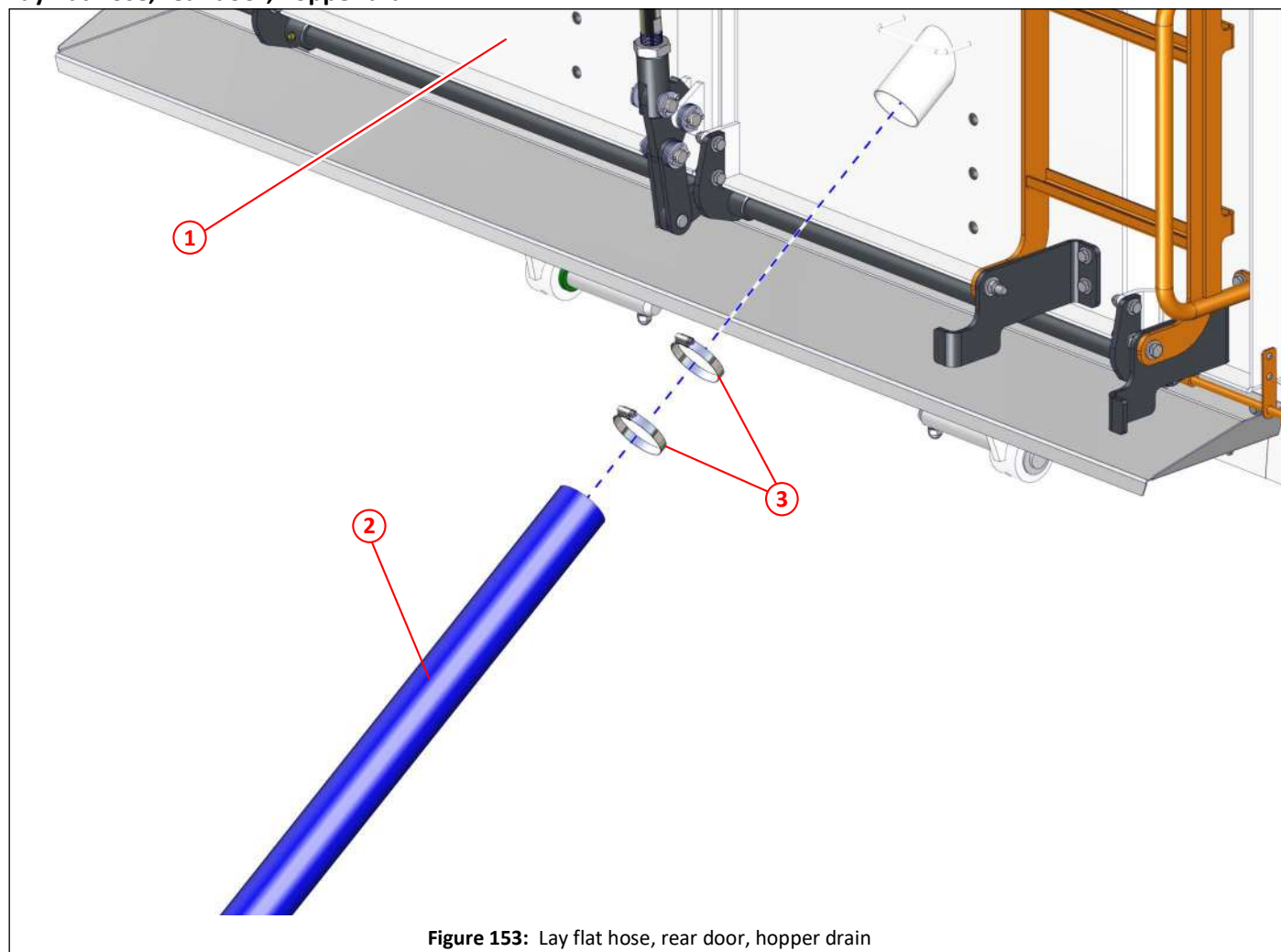

Figure 153: Lay flat hose, rear door, hopper drain

Item	Part No	Qty	Description	
①			Rear door, with inspection/access hatch	178
②	010998		Lay flat hose, blue	
③	012931	2	Hose clamp, worm drive, No. 4 (ø70mm-ø90mm)	



Rear door open/close/locking arrangement

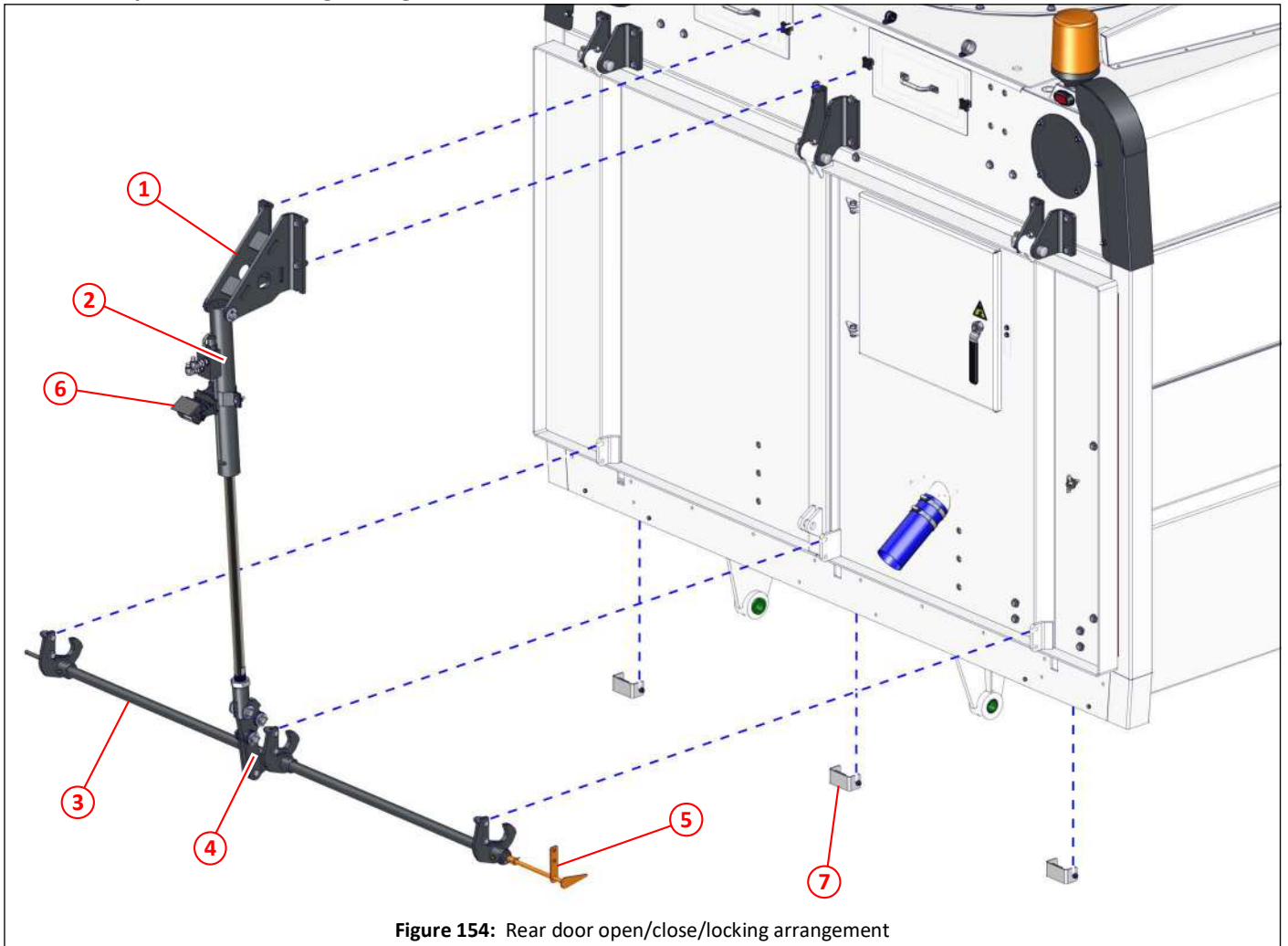

Figure 154: Rear door open/close/locking arrangement

Item	Part No	Qty	Description	
①	034309	1	Hinge, rear door ram	188
②	034816	1	Ram, rear door	189
③	034317		Locking bar, rear door	190
④			Locking cam arrangement	191
⑤	035654	1	Locking flag	190
⑥			Rear camera	193,329
⑦	034322	3	Wear plate, rear door locking	192

## Hinge, rear door ram

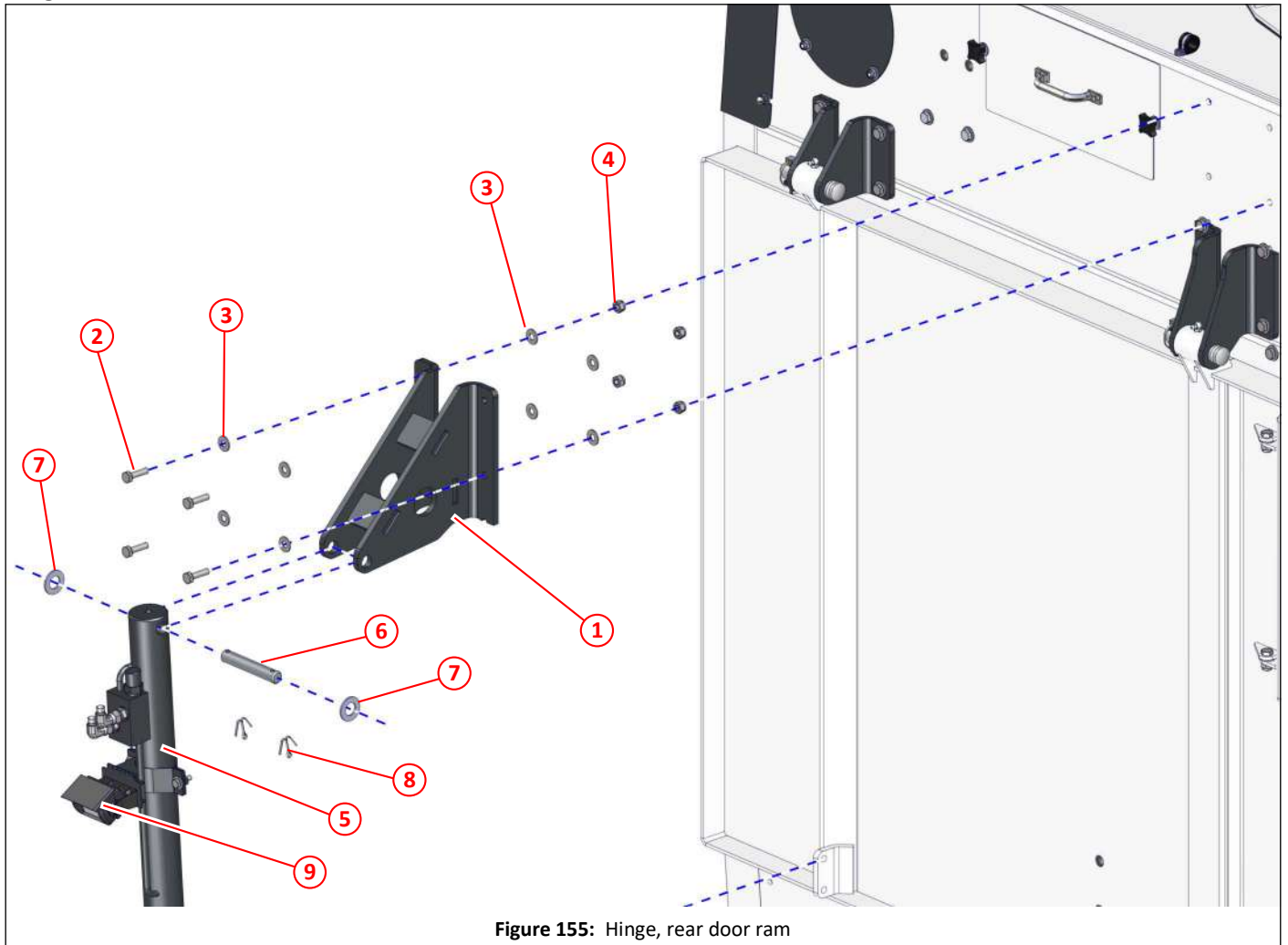

Figure 155: Hinge, rear door ram

Item	Part No	Qty	Description	
①	034309	1	Hinge, rear door ram	189
②	011033	4	Set screw M10 x 35	
③	011094	8	Plain washer M10	
④	011075	4	Nyloc nut M10	
⑤	034816	1	Ram, rear door	189
⑥	022558	1	Pin, rear door ram	
⑦	011102	2	Plain washer M20	
⑧	011122	2	Split pin $\frac{3}{16}$ " x $1\frac{1}{2}$ "	
⑨			Rear camera	193,329

Ram, rear door open/close/lock

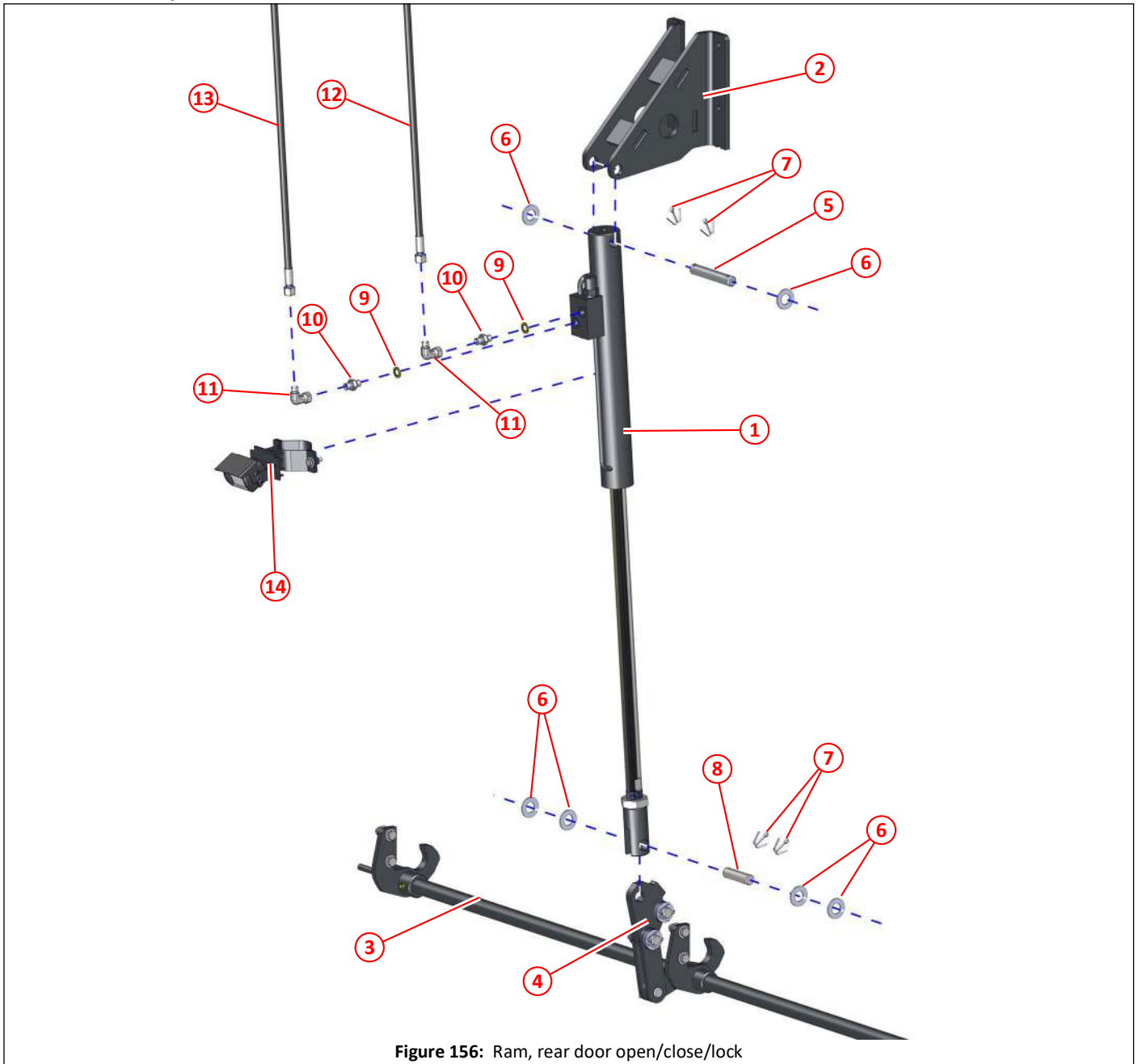

Figure 156: Ram, rear door open/close/lock

Item	Part No	Qty	Description	
①	034816	1	Ram, rear door	272
②	034309	1	Hinge, rear door ram	188
③	034317	1	Locking bar, rear door	190
④			Locking cam arrangement	191
⑤	022558	1	Pin, rear door ram	
⑥	011102	6	Plain washer M20	
⑦	011122	4	Split pin $\frac{3}{16}$ " x $1\frac{1}{2}$ "	
⑧	014038	1	Pin $\varnothing 20$ x 70	
⑨	011152	2	Dowty seal $\frac{1}{4}$ " BSP	
⑩	011158	2	Adapter, M/M, $\frac{1}{4}$ " BSP x $\frac{1}{4}$ " BSP	
⑪	011171	2	Elbow, swivel, M/F, $\frac{1}{4}$ " BSP	
⑫	011328	2	Hose, $\frac{1}{4}$ " BSP x 1780, straight ends,	
⑬	001321	1	Hose, $\frac{1}{4}$ " BSP x 1850, straight ends,	
⑭			Rear camera	193,329

Locking bar, rear door

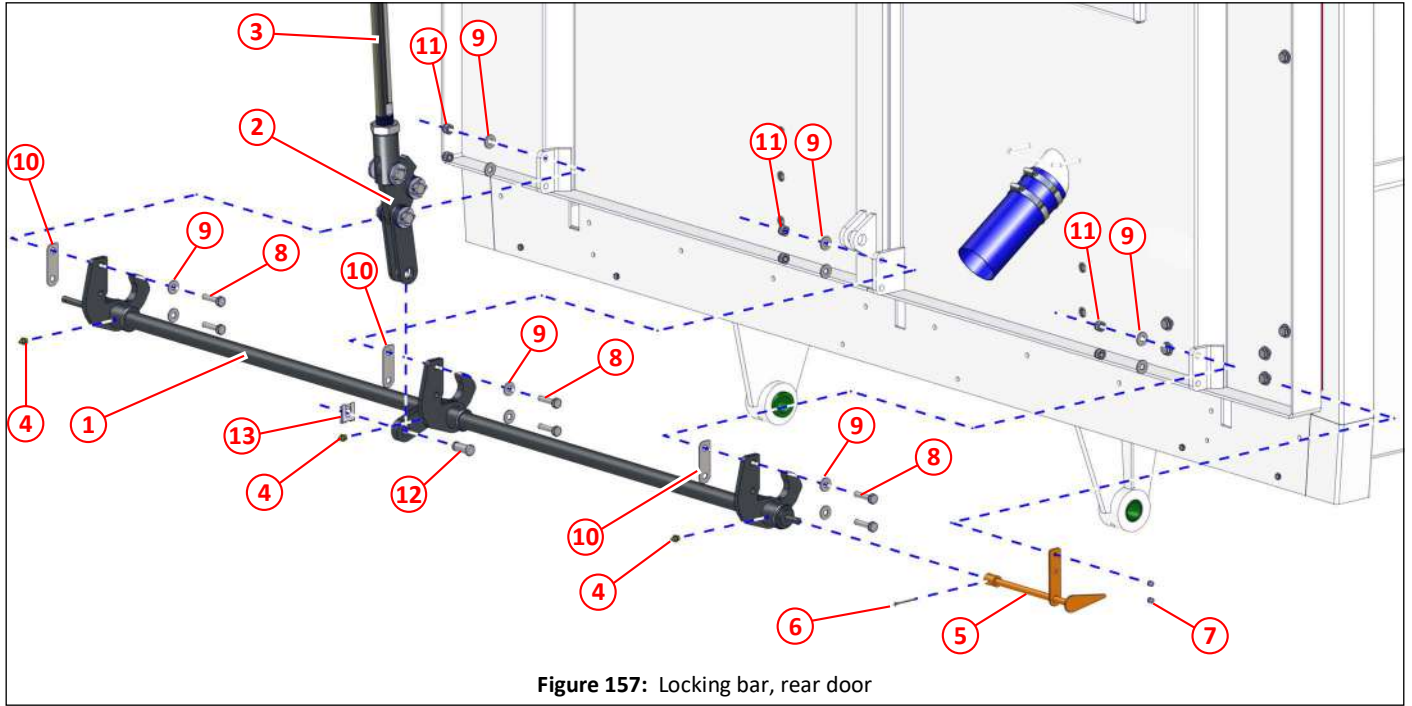

Figure 157: Locking bar, rear door

Item	Part No	Qty	Description	
①	034317	1	Locking bar, rear door	
②			Locking cam arrangement	191
③	034816	1	Ram, rear door	189
④	010903	3	Grease nipple $\frac{1}{8}$ " BSP, straight	
⑤	035654	1	Locking flag, fitted to drivers side of locking bar/hopper door	
⑥	000103	1	Split pin $\frac{5}{32}$ " x $1\frac{1}{2}$ "	
⑦	011131	2	Rivet, blind $\varnothing$ 4.8 x 18	
⑧	011034	6	Set screw M10 x 40	
⑨	011094	12	Plain washer M10	
⑩	038151	As req	Shim 1.5mm, rear door locking bar	
⑪	038149	As req	Shim 2mm, rear door locking bar	
⑫	011075	6	Nyloc nut M10	
⑬	022673	1	Clevis pin, turned	
⑭	022674	1	Clip, retaining, M16	

Locking cam, rear door

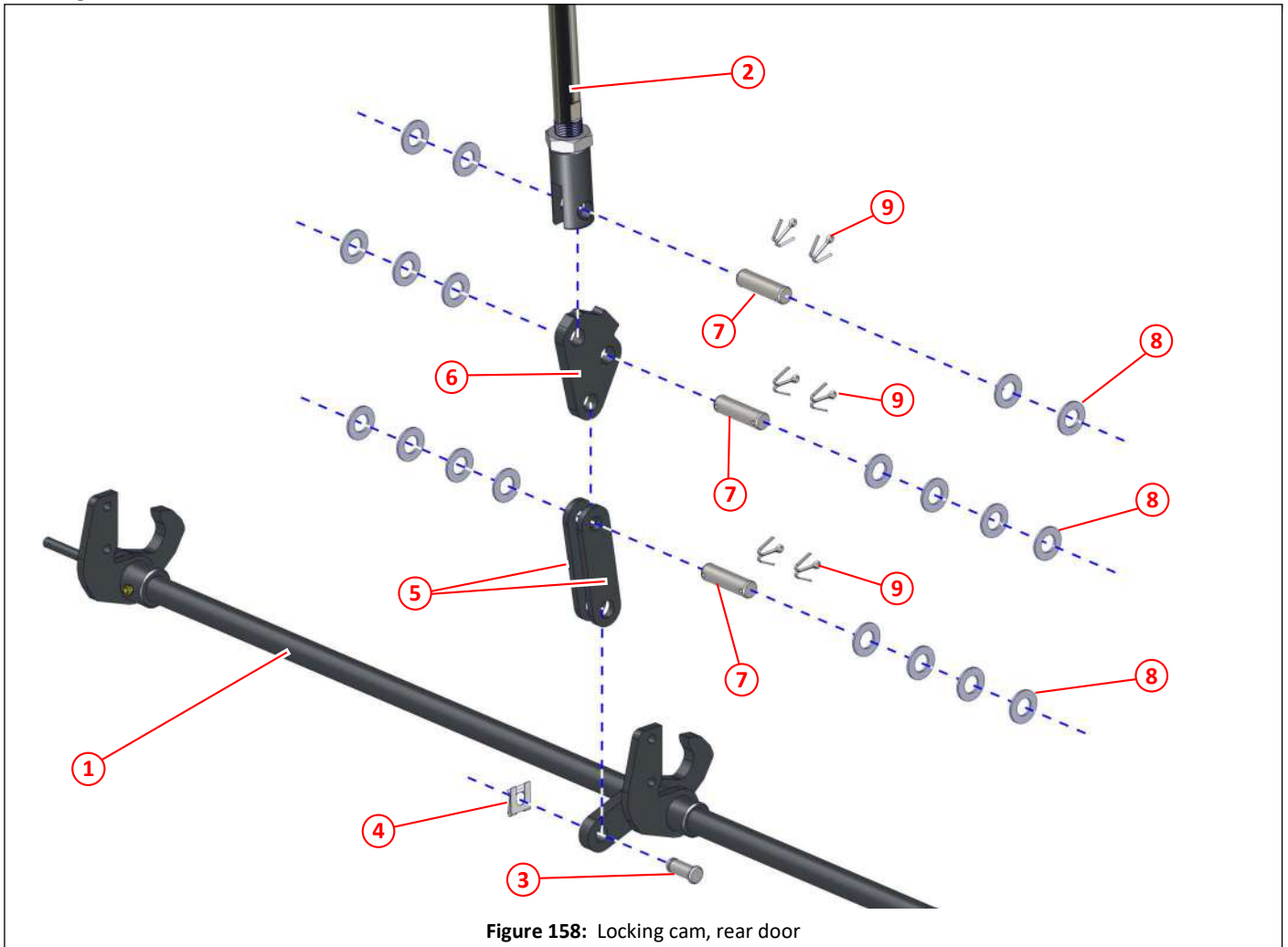

Figure 158: Locking cam, rear door

Item	Part No	Qty	Description	
①	034317	1	Locking bar, rear door open/close/lock	187,189,190
②	034816	1	Ram, rear door	189
③	022673	1	Clevis pin, turned	
④	022674	1	Clip, retaining, M16	
⑤	034315	2	Push link, door locking	
⑥	034314	1	Cam, door locking	
⑦	014038	3	Pin $\varnothing 20 \times 70$	
⑧	011102	19	Plain washer M20	
⑨	011122	6	Split pin $\frac{3}{16}'' \times 1\frac{1}{2}''$	

## Locking wear plates, rear door

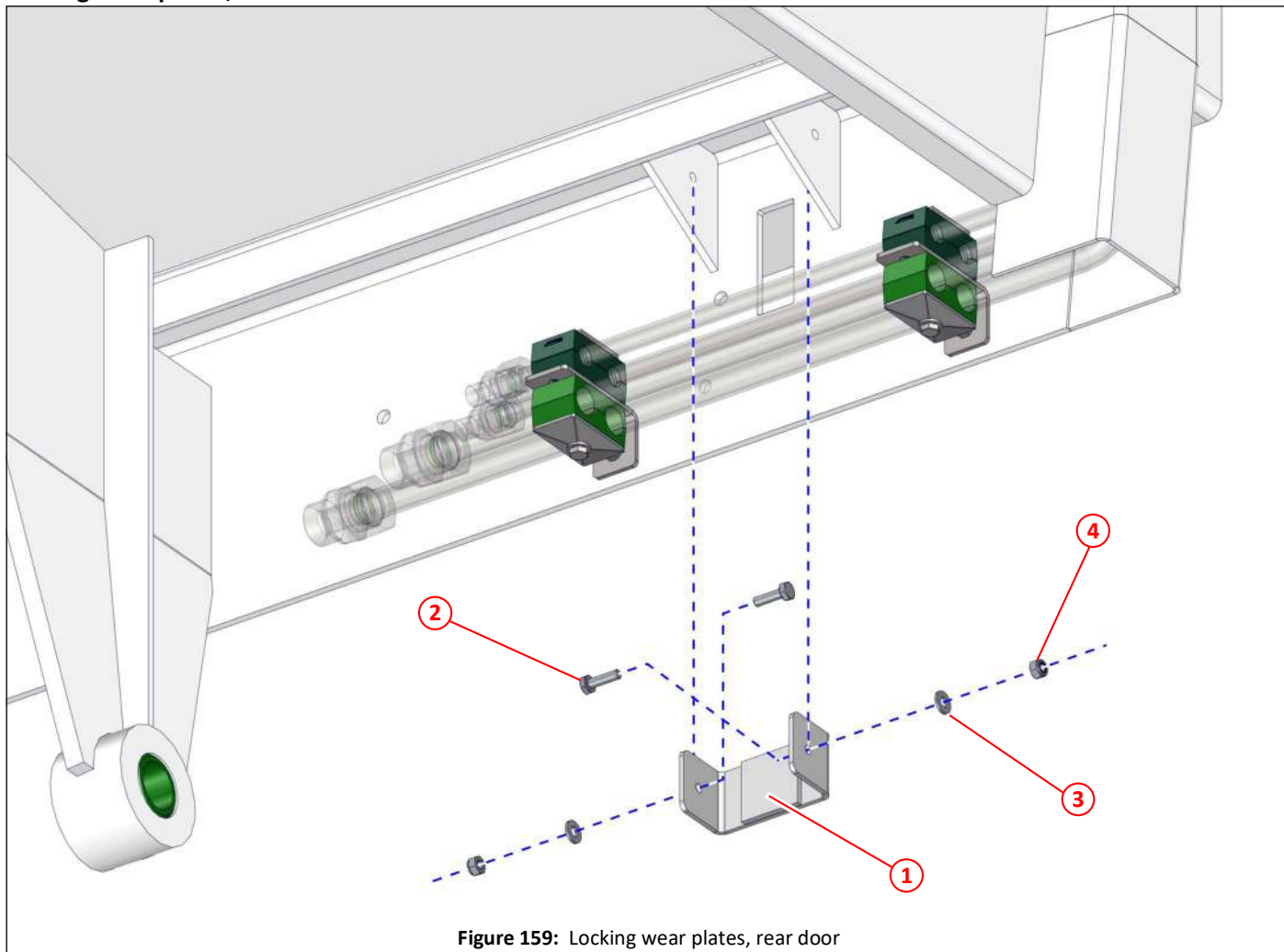

Figure 159: Locking wear plates, rear door

Item	Part No	Qty	Description	
①	034322	1	Wear plate, rear door locking	187
②	000252	2	Set screw M6 x 20, stainless steel	
③	000254	2	Plain washer M6, stainless steel	
④	000253	2	Nyloc nut M6, stainless steel	



Rear camera mountings

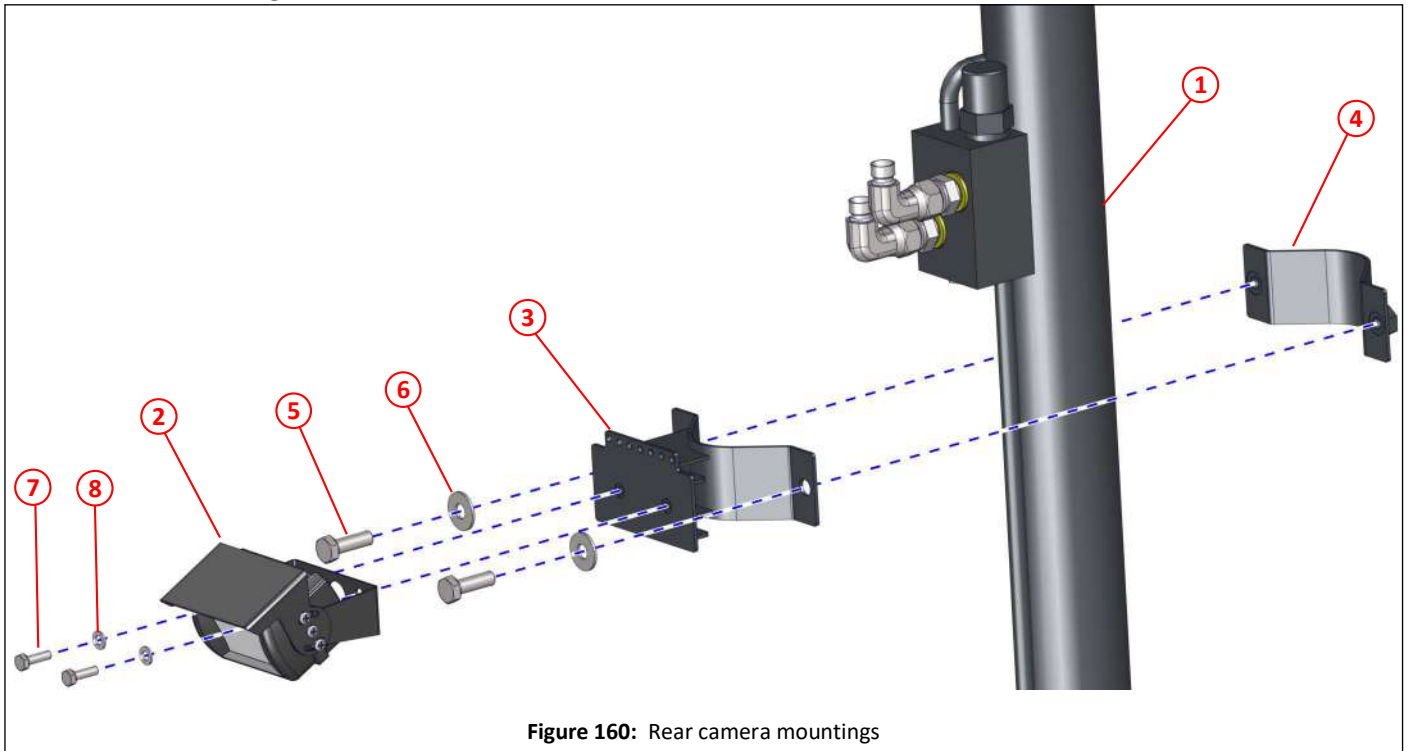

Figure 160: Rear camera mountings

Item	Part No	Qty	Description	
①	034816	1	Ram, rear door	189
②	040354	1	Camera	329
③	040676	1	Front clamp, camera mount	
④	040677	1	Rear clamp, camera mounting	
⑤	011011	2	SETSCREW M8 X 25	
⑥	011092	2	Plain washer M8	
⑦	000052	2	Bolt M5 X 16	
⑧	000410	2	Plain washer M5	

Direction sign, rear door mounted

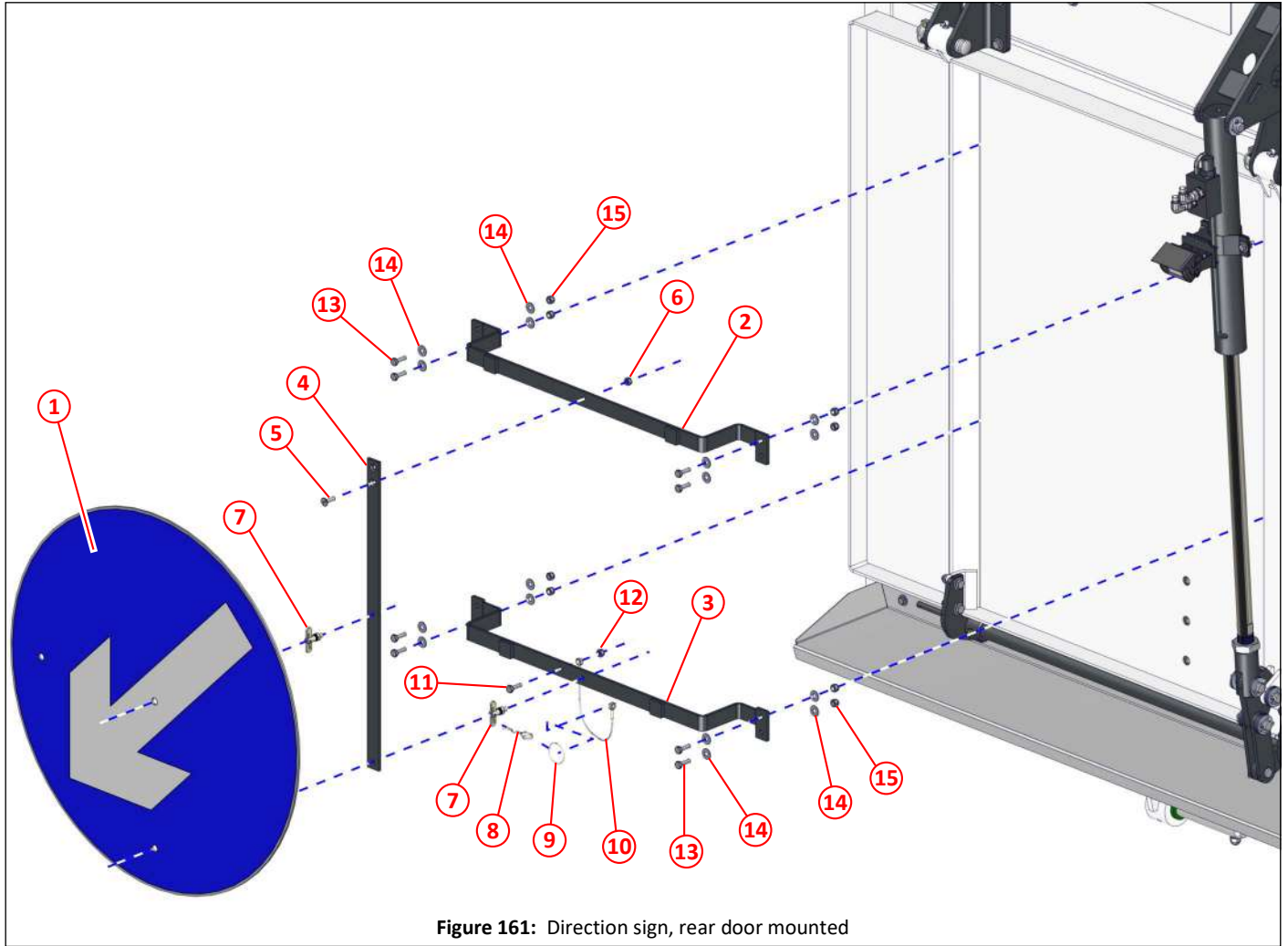

Figure 161: Direction sign, rear door mounted

Item	Part No	Qty	Description
①	021869	1	Direction arrow sign, ø750
②	035818	1	Support bracket, upper, rear sign
③	035819	1	Support bracket, lower, rear sign
④	031978	1	Support bar, centre, rear sign
⑤	000109	1	Countersunk slotted screw M8 x 25
⑥	011073	1	Nyloc nut M8
⑦	012253	2	Antiluce, small, includes star washer and nut
⑧	021944	1	R-Clip, grip, double wound (ø3 wire)
⑨	023599	1	Ring
⑩	020711	1	Leash cable
⑪	000257	1	Set screw M8 x 25, stainless steel
⑫	011073	1	Nyloc nut M8
⑬	000257	8	Set screw M8 x 25, stainless steel
⑭	000264	16	Plain washer M8, stainless steel
⑮	000263	8	Nyloc nut M8, stainless steel

# Water

<i>Description</i>	<i>Page</i>
Water system layout . . . . .	196
Water tank . . . . .	198
Water tank anti-vibration mountings . . . . .	199
Water tank mounting support plates . . . . .	200
Water level sight tube, water tank . . . . .	201
Lid, water tank . . . . .	202
Fittings, water tank, front . . . . .	203
Drain, water tank . . . . .	204
Drain, water tank, when auxiliary water tank fitted . . . . .	205
Fittings, water tank, rear . . . . .	206
Auxiliary water tank, 650 litre (172 US gallons), mounting location . . . . .	207
Auxiliary water tank, 650 litre (172 US gallons) . . . . .	208
Auxiliary water tank, lower mounting brackets . . . . .	209
Auxiliary water tank, upper mounting braces . . . . .	210
Auxiliary water tank, filler lid . . . . .	211
Auxiliary water tank, sight tube . . . . .	212
Auxiliary water tank, valve fittings . . . . .	213
Water strainer, low pressure . . . . .	214
Water pump, twin diaphragm, low pressure, mounting . . . . .	215
Water pump, twin diaphragm, low pressure, fittings . . . . .	216
Water pump, twin diaphragm, low pressure, components . . . . .	217
Water valves, location . . . . .	218
Water valves, 2-way, mounting . . . . .	219
Water valves, 3-way, mounting . . . . .	220
Water valves, 4-way, mounting . . . . .	221
Water valves, 5-way, mounting . . . . .	222
Water valves, 6-way, mounting . . . . .	223
Water valve components . . . . .	224
Water spray nozzle, twin, left hand side brush . . . . .	225
Water spray nozzle, twin, right hand side brush . . . . .	226
Water spray nozzles, suction nozzle box . . . . .	227
Water spray nozzles, suction spigot . . . . .	228
Front spray bar, low pressure . . . . .	229
Water nozzle, overhead boom suction tube . . . . .	230
High pressure water sy . . . . .	231
Water strainer, high pressure . . . . .	231
Water pump, high pressure 30 LPM, mounting, motor and coupling . . . . .	232
Water pump, high pressure 30 LPM, feed, output and return fittings . . . . .	233
Water pump, high pressure 30 LPM, drainage fittings . . . . .	234
Water pump, high pressure 30 LPM, seal kits . . . . .	235
Front spray bar, combined high pressure/low pressure . . . . .	236
Shut off valve and low pressure non return valve, combined front spray bar . . . . .	237
Hose reel and mounting . . . . .	238
Hand lance and mounting . . . . .	239
Spray bar, high pressure, front of suction nozzle, mounting . . . . .	240
Spray bar, high pressure, front of suction nozzle, water feed and shut off valve . . . . .	241
Spray bar, high pressure, rear of suction nozzle, mounting . . . . .	242
Spray bar, high pressure, rear of suction nozzle, water feed and shut off valve . . . . .	243
Spray bar, high pressure, central brush (wide sweep), mounting, water feed and shut off valve . . . . .	244
Fan wash assist . . . . .	245

Water system layout

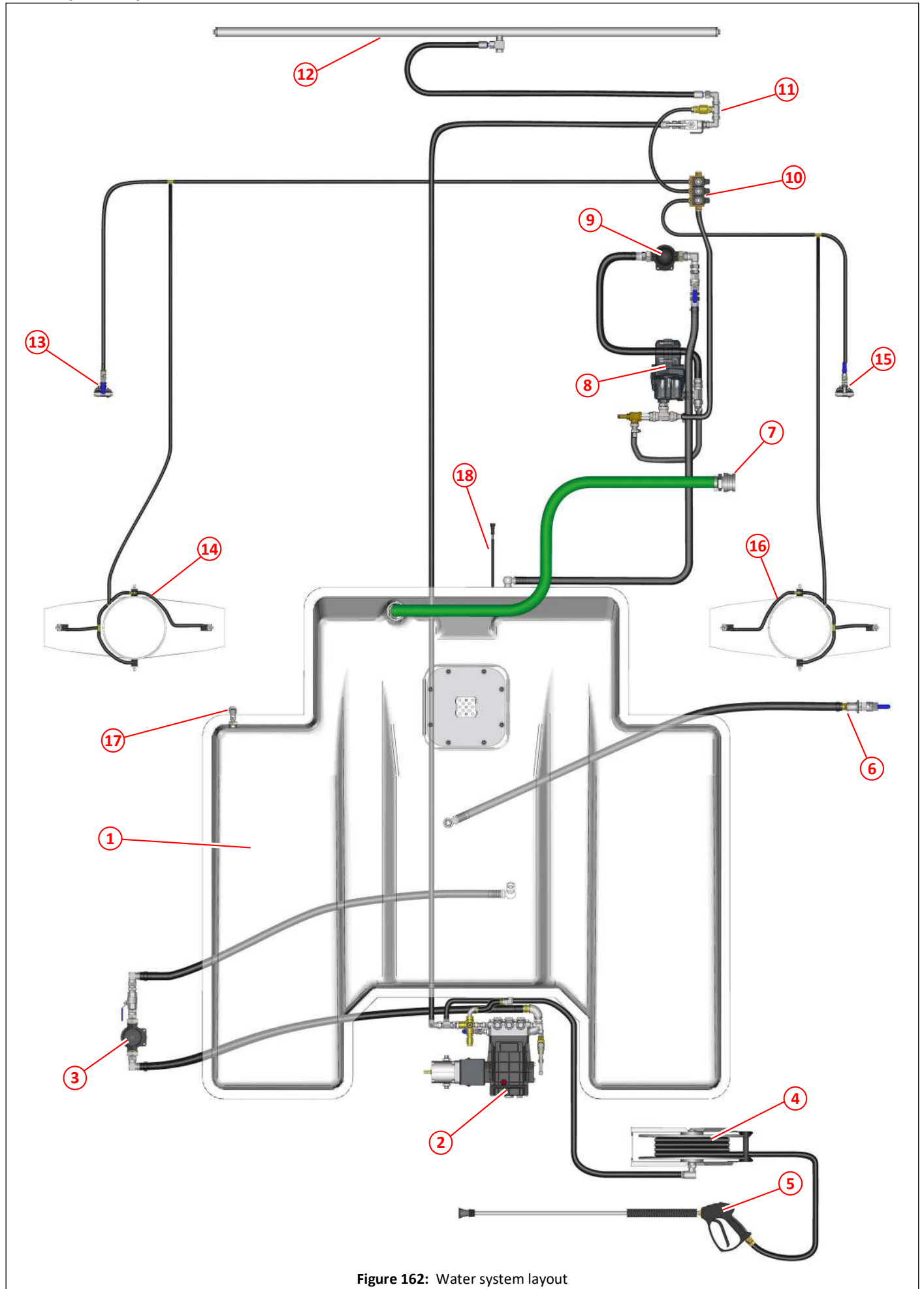



Figure 162: Water system layout

Water system layout

Item	Part No	Qty	Description	
①			Water tank	198
②			Water pump, high pressure	232
③			Water strainer, high pressure	231
④			Hose reel	238
⑤			Hand lance	239
⑥			Water tank drain	204
⑦			Water filler	177
⑧			Water pump, low pressure	215
⑨			Water strainer, low pressure	214
⑩			Water valves	218
⑪			Front spray bar tap	237
⑫			Front spray bar	229
⑬			Water spray nozzles, left hand side brush	225
⑭			Water spray nozzles, left hand suction nozzle	227
⑮			Water spray nozzles, right hand side brush	226
⑯			Water spray nozzles, right hand suction nozzle	227
⑰			Water level sight tube	201
⑱			Water level float switch	203

 Dual sweep sweeper with high pressure water pump shown. Other sweepers will differ depending on configuration

Water tank

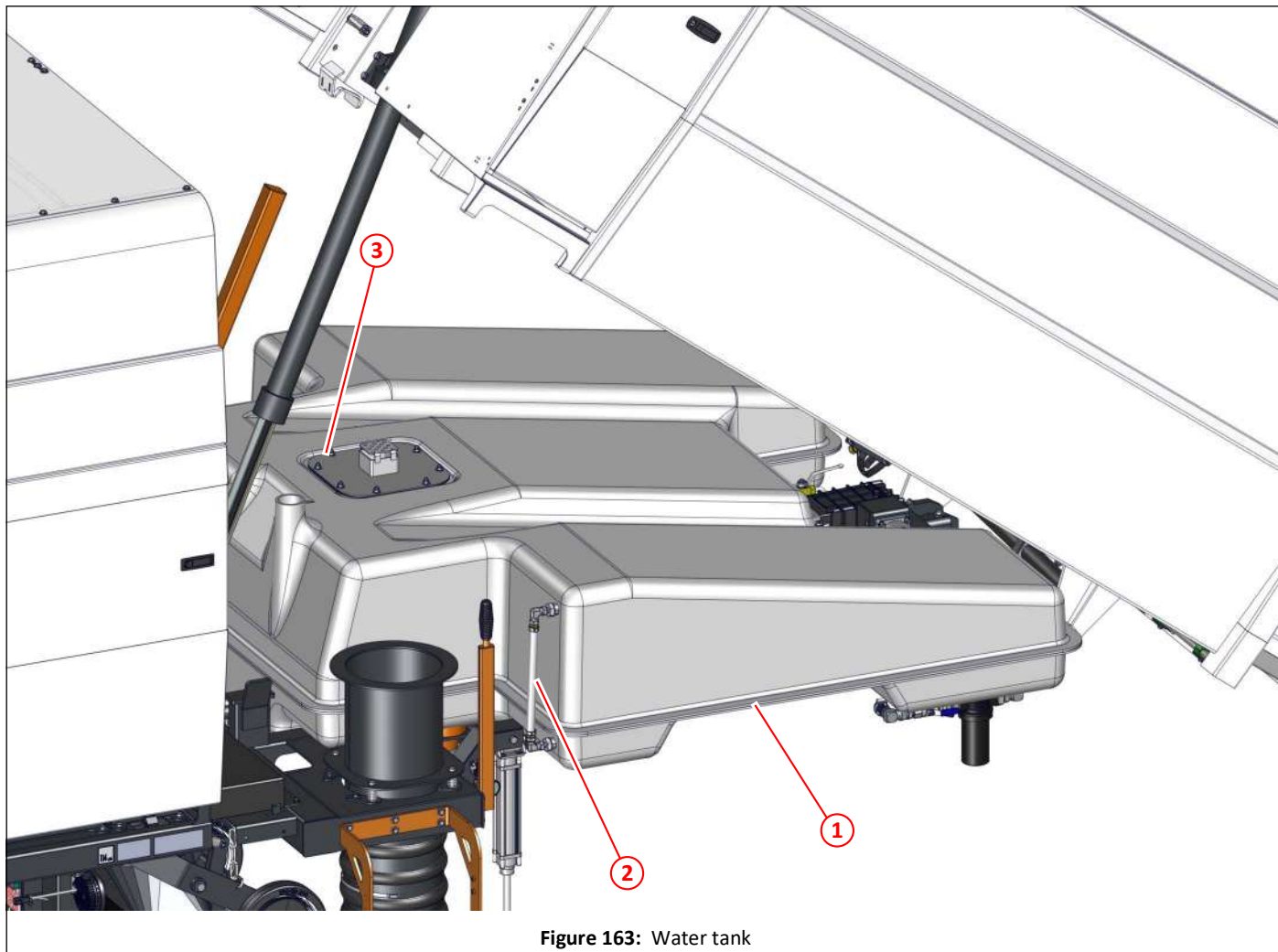

Figure 163: Water tank

Item	Part No	Qty	Description	
①	050809	1	Water tank	
②			Water level sight tube	201
③	034760		Lid, water tank	



Water tank anti-vibration mountings

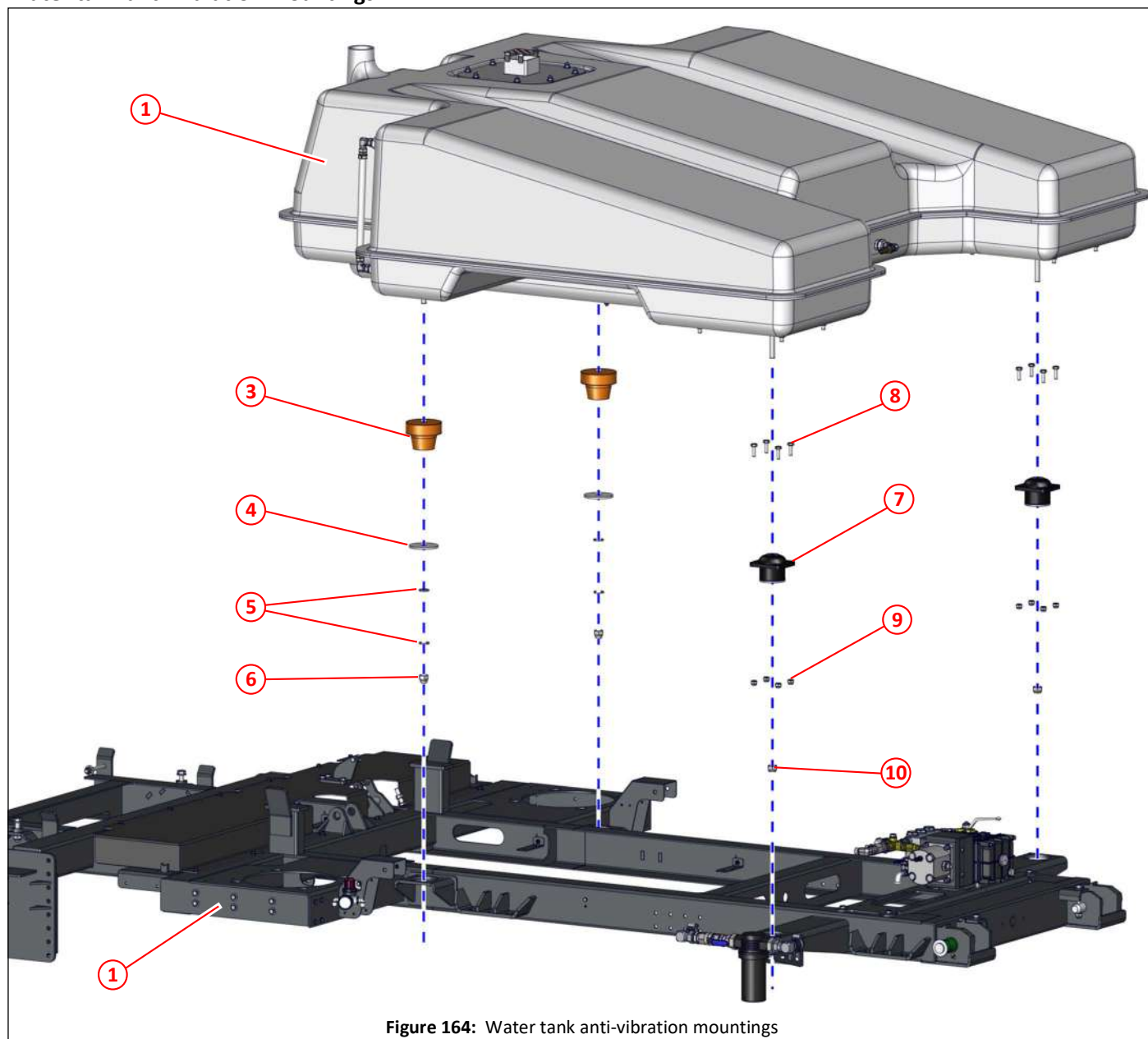

Figure 164: Water tank anti-vibration mountings

Item	Part No	Qty	Description	
①	042942	1	Subframe	365
②	050809	1	Water tank	
③	044509	2	Bush, orange, water tank	
④	044623	2	Washer $\phi 16.5 \times \phi 85 \times 5$	
⑤	011135	4	Plain washer M16	
⑥	000493	2	Nut, dome, M16, DIN 1587	
⑦	033838	2	Mounting, anti-vibration, MS243/5 (HD type), water tank	366
⑧	011032	8	Set screw M10 x 30	
⑨	011075	8	Nyloc nut M10	
⑩	011060	2	Nyloc nut M16	

Water tank mounting support plates

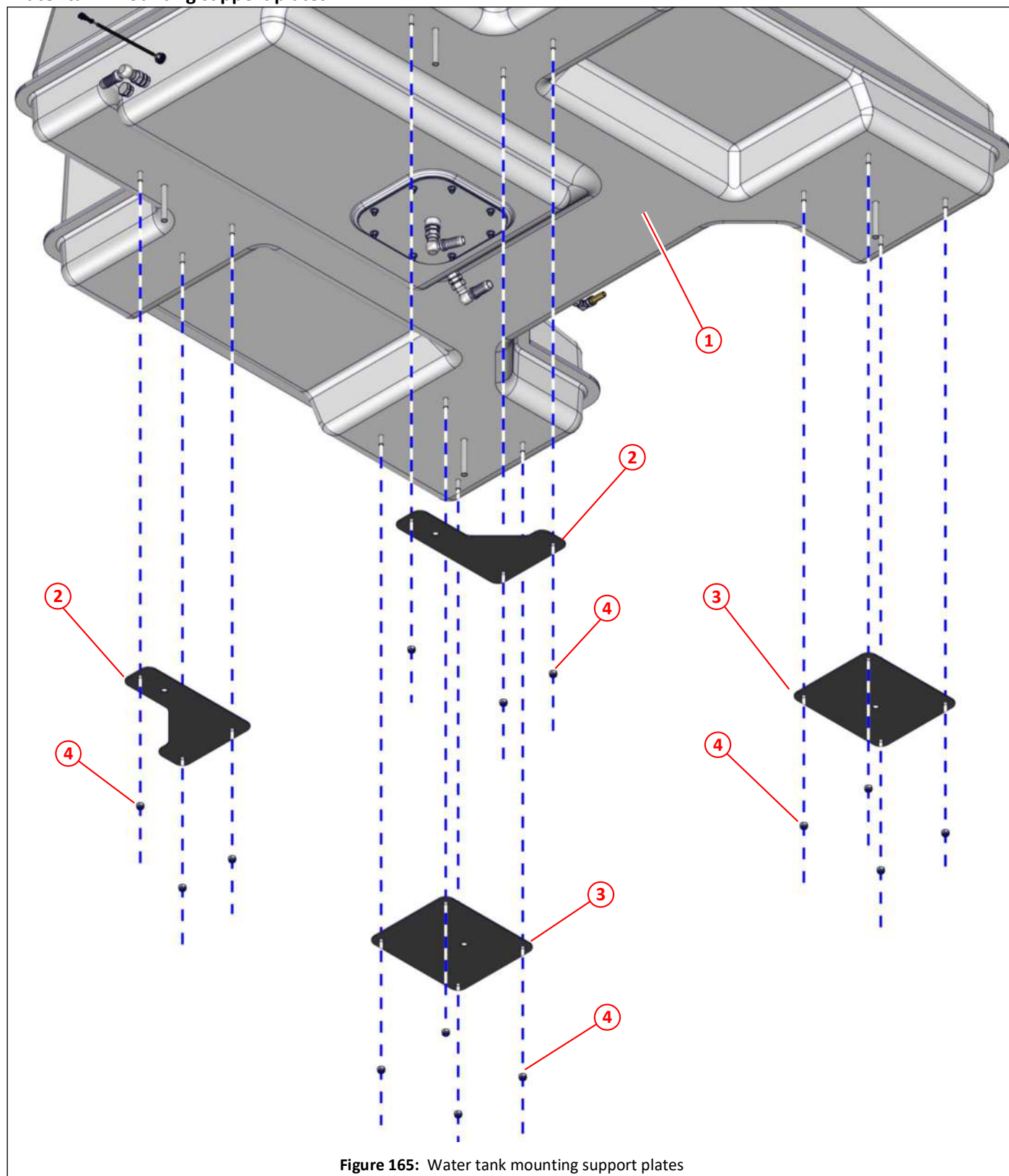

Figure 165: Water tank mounting support plates

Item	Part No	Qty	Description
①	050809	1	Water tank
②	034871	2	Support plate, front
③	034872	2	Support plate, rear
④	011077		Nyloc nut M12

Water level sight tube, water tank

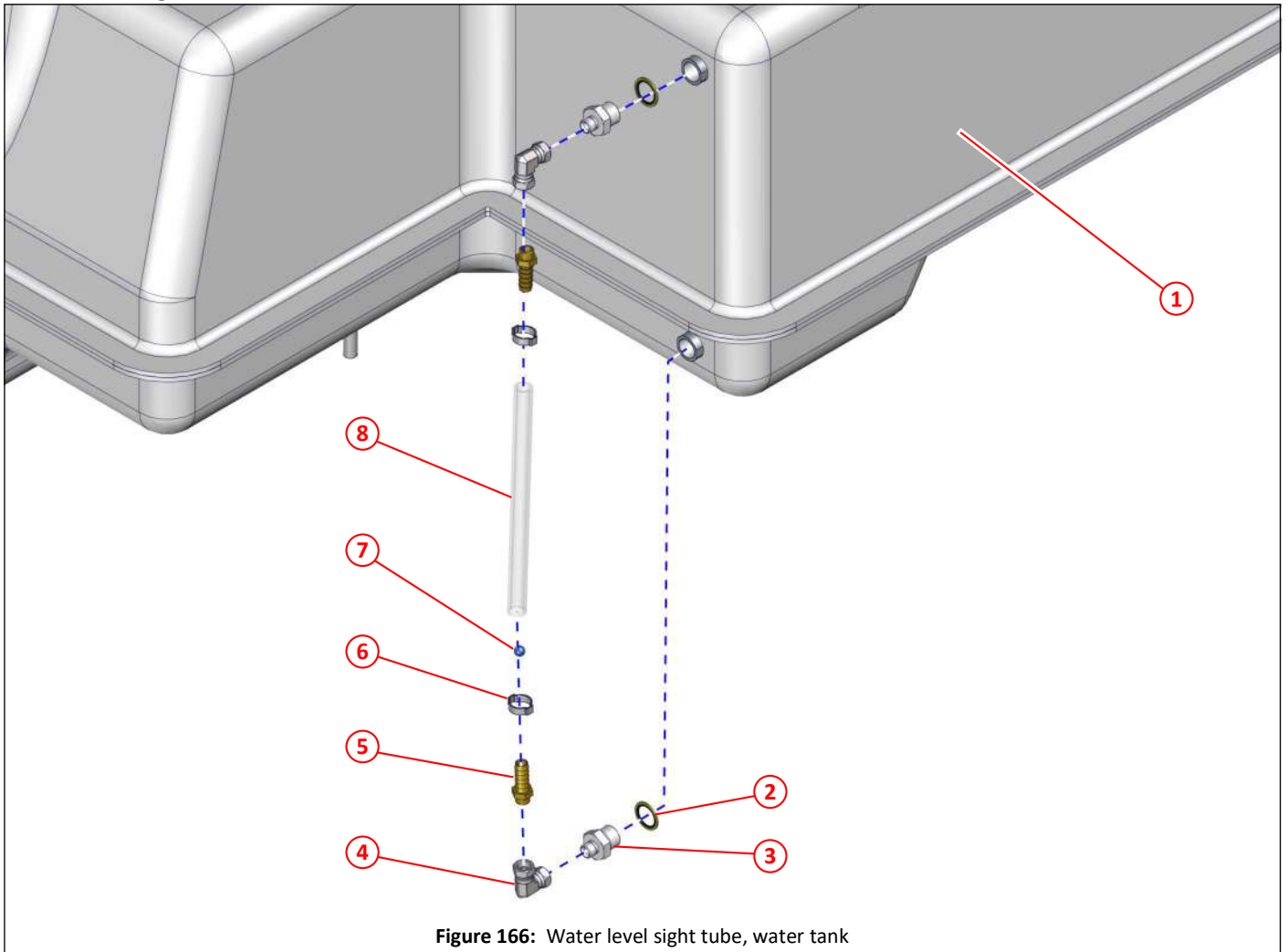

Figure 166: Water level sight tube, water tank

Item	Part No	Qty	Description
①	050809	1	Water tank
②	011155	2	Dowty seal, $\frac{3}{4}$ " BSP
③	011224	2	Adapter, $\frac{3}{4}$ " BSP x $\frac{3}{8}$ " BSP
④	011205	2	Elbow, swivel, F/F, $\frac{3}{8}$ " BSP
⑤	010930	2	Adapter, $\frac{3}{8}$ " BSP x $\frac{5}{8}$ ", hose tail
⑥	000202	2	O-Clip $\frac{7}{8}$ "
⑦	025335	1	Ball, plastic, $\frac{1}{2}$ "
⑧	040424	300mm	PVC tube, clear, $\frac{5}{8}$ "

Lid, water tank

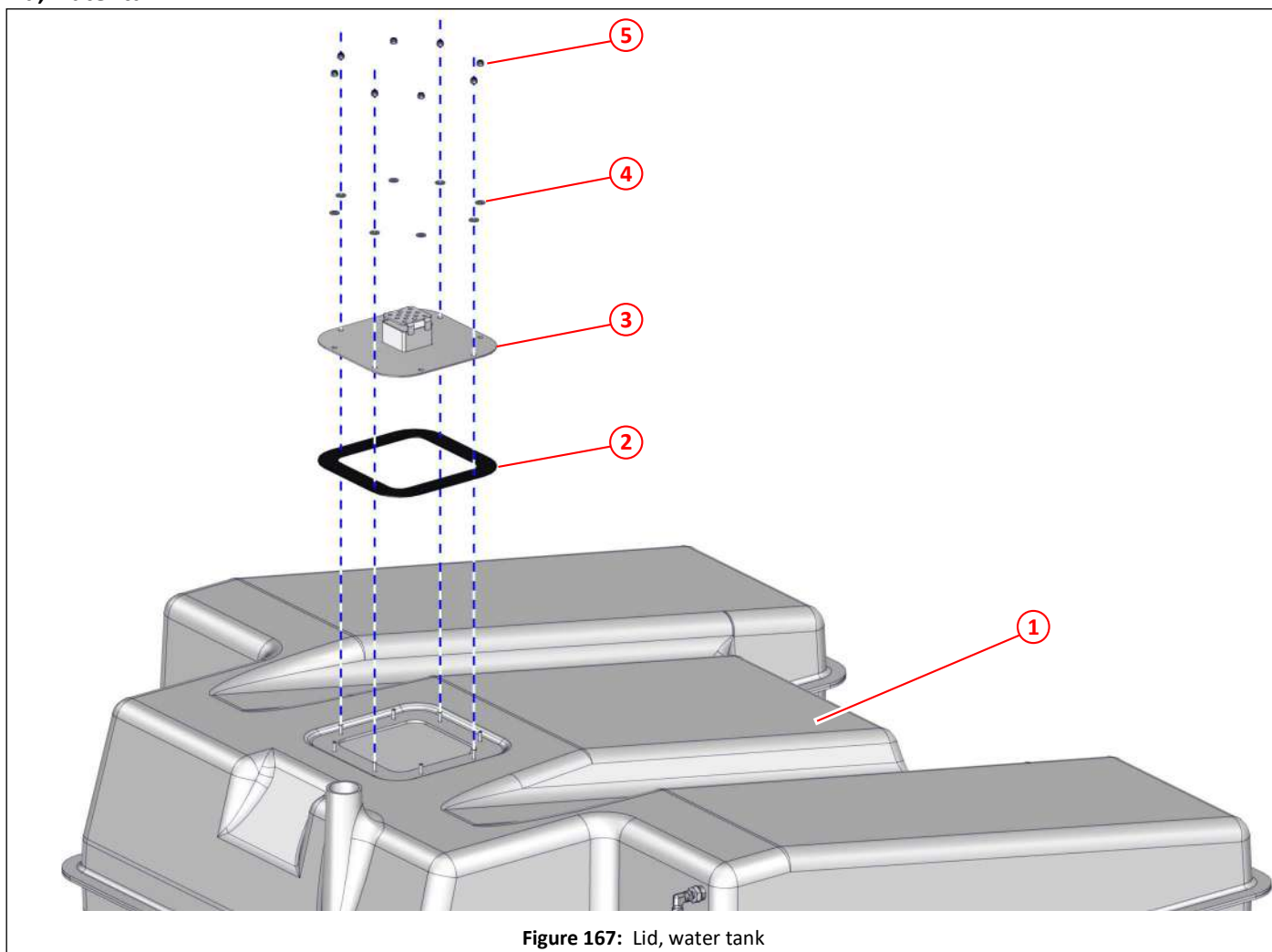

Figure 167: Lid, water tank

Item	Part No	Qty	Description
①	050809	1	Water tank
②	034873	1	Gasket, water tank
③	034760	1	Lid, water tank
④	000264	8	Plain washer, M8, stainless steel
⑤	000263	8	Nyloc nut M8, stainless steel

Fittings, water tank, front

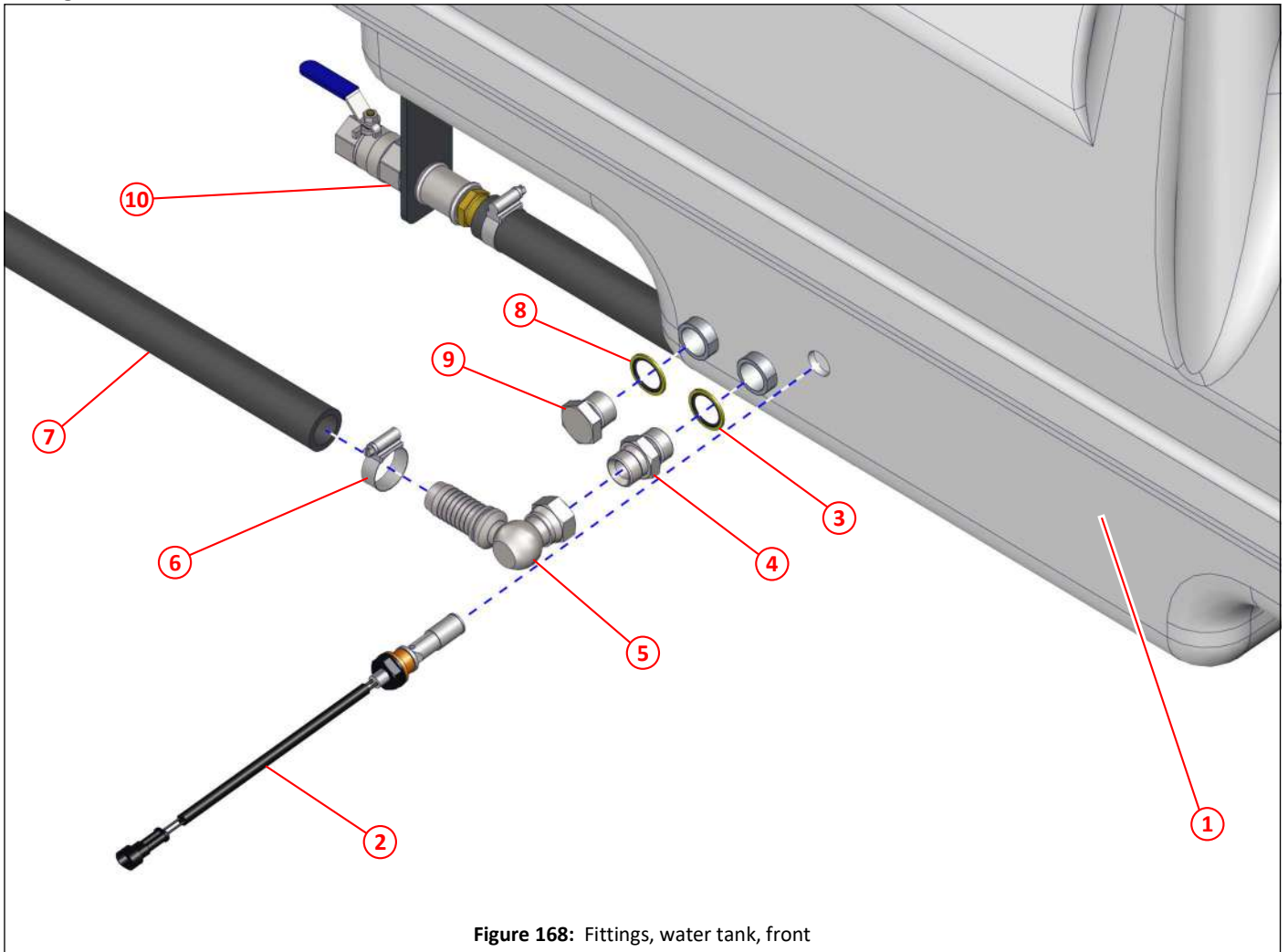

Figure 168: Fittings, water tank, front

Item	Part No	Qty	Description	
①	050809	1	Water tank	
②	038671	1	Float switch, with amp plug	
③	011155	1	Dowty seal, $\frac{3}{4}$ " BSP	
④	011161	1	Adapter, $\frac{3}{4}$ " BSP	
⑤	002203	1	Elbow, $\frac{3}{4}$ " BSP x 1", hose tail	
⑥	010518	1	Hose clamp, worm drive, No. 1X ( $\phi 30-\phi 40$ )	
⑦	010959	As req	Hose, 1", to water filter	
⑧	011155	1	Dowty seal, $\frac{3}{4}$ " BSP	
⑨	011244	1	Plug, $\frac{3}{4}$ " BSP	
⑩			Water tank drain	204



Drain, water tank

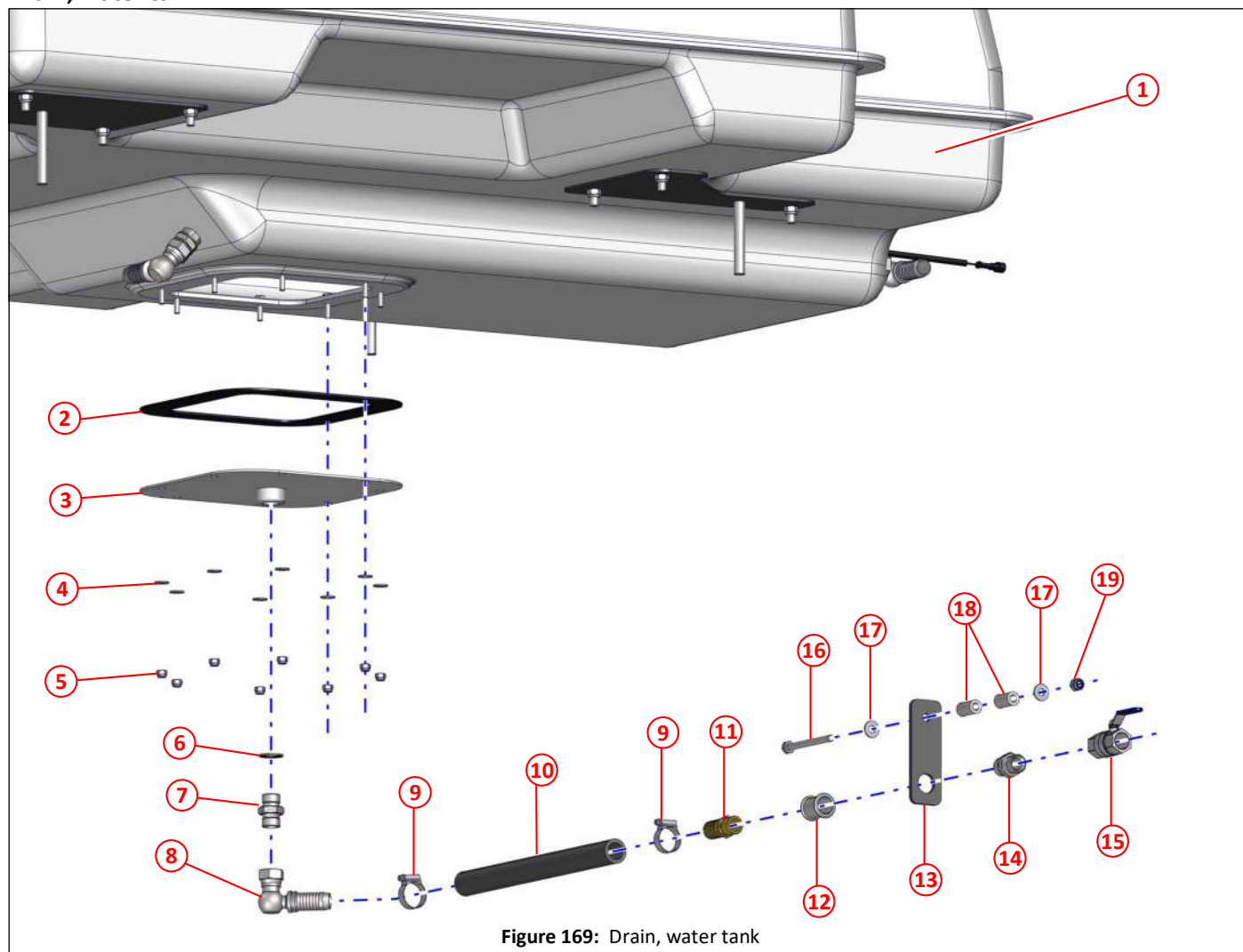

Figure 169: Drain, water tank

Item	Part No	Qty	Description
①	050809	1	Water tank
②	034873	1	Gasket, water tank
③	034780	1	Sump plate, water tank
④	000264	8	Plain washer, M8, stainless steel
⑤	000263	8	Nyloc nut, M8, stainless steel
⑥	011155	1	Dowty seal, $\frac{3}{4}$ " BSP
⑦	011161	1	Adapter, $\frac{3}{4}$ " BSP
⑧	002203	1	Elbow, $\frac{3}{4}$ " BSP x 1", hose tail
⑨	010518	2	Hose clamp, worm drive, No. 1X ( $\phi$ 30- $\phi$ 40)
⑩	010959	As req	Hose, 1"
⑪	010931	1	Adapter, male $\frac{3}{4}$ " BSP x 1", hose tail
⑫	010934	1	Socket, $\frac{3}{4}$ " BSP
⑬	021848	1	Bracket, water tank drain
⑭	011161	1	Adapter, $\frac{3}{4}$ " BSP
⑮	013757	1	Valve, ball, $\frac{3}{4}$ " BSP
⑯	011842	1	Bolt M10 x 110
⑰	000270	2	Plain washer, M10, stainless steel
⑱	037723	2	Spacer
⑲	000269	1	Nyloc nut, M10, stainless steel



Drain, water tank, when auxiliary water tank fitted

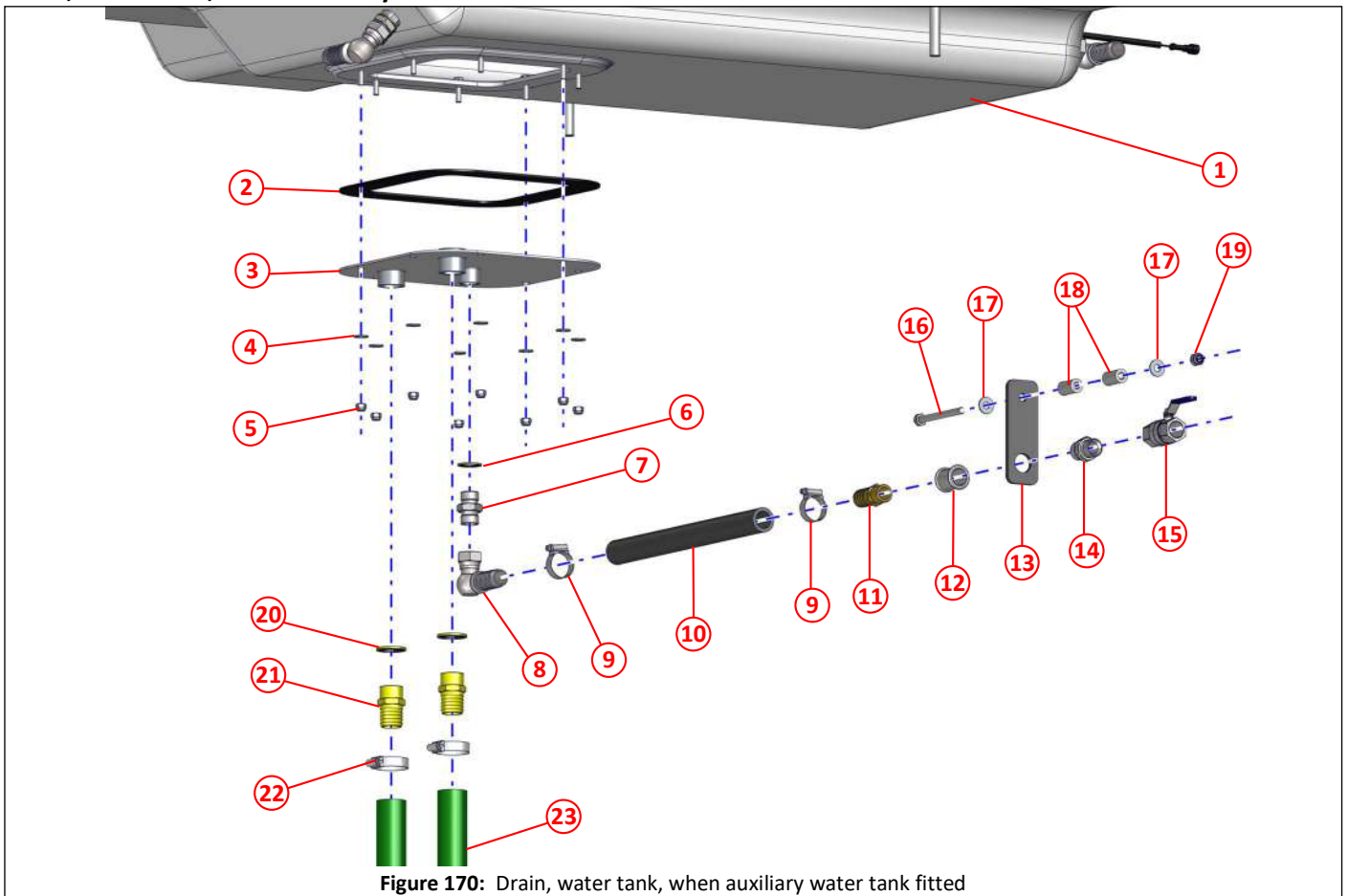

Figure 170: Drain, water tank, when auxiliary water tank fitted

Item	Part No	Qty	Description
①	050809	1	Water tank
②	034873	1	Gasket, water tank
③	040135	1	Sump plate, water tank, with auxiliary water tank
④	000264	8	Plain washer, M8, stainless steel
⑤	000263	8	Nyloc nut M8, stainless steel
⑥	011155	1	Dowty seal, 3/4" BSP
⑦	011161	1	Adapter, 3/4" BSP
⑧	002203	1	Elbow, 3/4" BSP x 1", hose tail
⑨	010518	2	Hose clamp, worm drive, No. 1X (ø30-ø40)
⑩	010959	As req	Hose, 1"
⑪	010931	1	Adapter, male 3/4" BSP x 1", hose tail
⑫	010934	1	Socket, 3/4" BSP
⑬	021848	1	Bracket, water tank drain
⑭	011161	1	Adapter, 3/4" BSP
⑮	013757	1	Valve, ball, 3/4" BSP
⑯	011842	1	Bolt M10 x 110
⑰	000270	2	Plain washer, M10, stainless steel
⑱	037723	2	Spacer
⑲	000269	1	Nyloc nut, M10, stainless steel
⑳	011156	2	Dowty seal, 1" BSP
㉑	003029	2	Adapter, male 1" BSP x 1 1/4" hose tail
㉒	003007	2	Hose clamp, worm drive, No. 2A (ø35-ø50)
㉓	001077	As req	Hose, green medium duty, id 1 1/4"

Fittings, water tank, rear

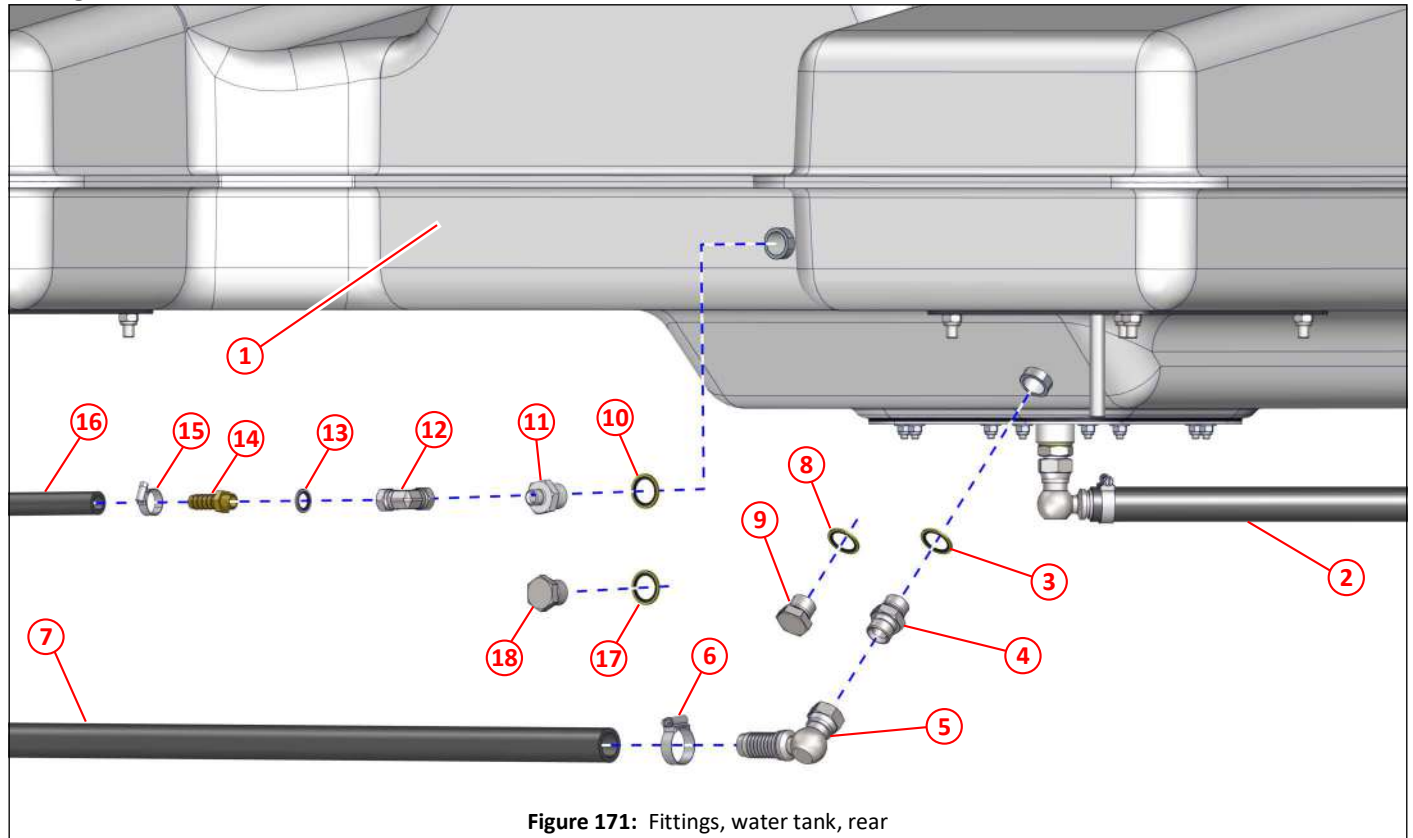

Figure 171: Fittings, water tank, rear

Item	Part No	Qty	Description	
①	050809	1	Water tank	
②			Water tank drain	204
③	011155	1	Dowty seal, $\frac{3}{4}$ " BSP	
④	011161	1	Adapter, $\frac{3}{4}$ " BSP	
⑤	002203	1	Elbow, $\frac{3}{4}$ " BSP x 1", hose tail	
⑥	010518	1	Hose clamp, worm drive, No. 1X ( $\phi$ 30- $\phi$ 40)	
⑦	010959	As req	Hose, 1", to water filter (for high pressure)	
⑧	011155*	1	Dowty seal, $\frac{3}{4}$ " BSP	
⑨	011244*	1	Plug, $\frac{3}{4}$ " BSP	
⑩	011155	1	Dowty seal, $\frac{3}{4}$ " BSP	
⑪	011224	1	Adapter, $\frac{3}{4}$ " BSP x $\frac{3}{8}$ " BSP	
⑫	011205	1	Elbow, swivel, F/F, $\frac{3}{8}$ " BSP	
⑬	011153	1	Dowty seal $\frac{3}{8}$ " BSP	
⑭	010930	1	Adapter, $\frac{3}{8}$ " BSP x $\frac{5}{8}$ ", hose tail	
⑮	010517	1	Hose clamp, worm drive, No. 0X ( $\phi$ 18- $\phi$ 25)	
⑯	011000	As req	Hose, $\frac{5}{8}$ ", return from high pressure pump	
⑰	011155*	1	Dowty seal, $\frac{3}{4}$ " BSP	
⑱	011244*	1	Plug, $\frac{3}{4}$ " BSP	

\*. These items are used to blank the associated bosses if sweeper is not fitted with high pressure water system.

Auxiliary water tank, 650 litre (172 US gallons), mounting location

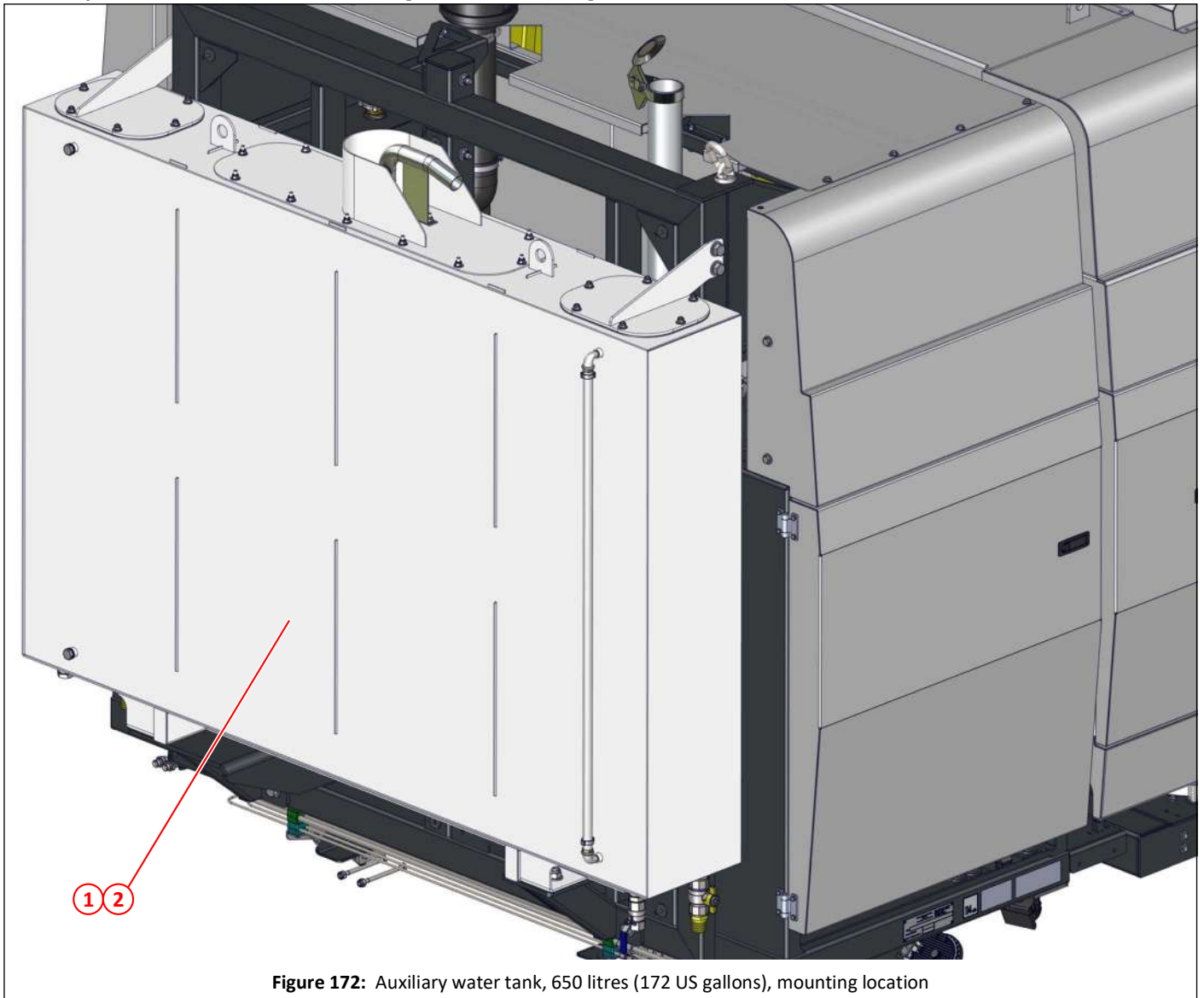

Figure 172: Auxiliary water tank, 650 litres (172 US gallons), mounting location

Item	Part No	Qty	Description	
①	043134	1	Auxiliary water tank complete assembly without mounting brackets	
②	043104	1	Auxiliary water tank, just the tank with no fittings	

Auxiliary water tank, 650 litre (172 US gallons)

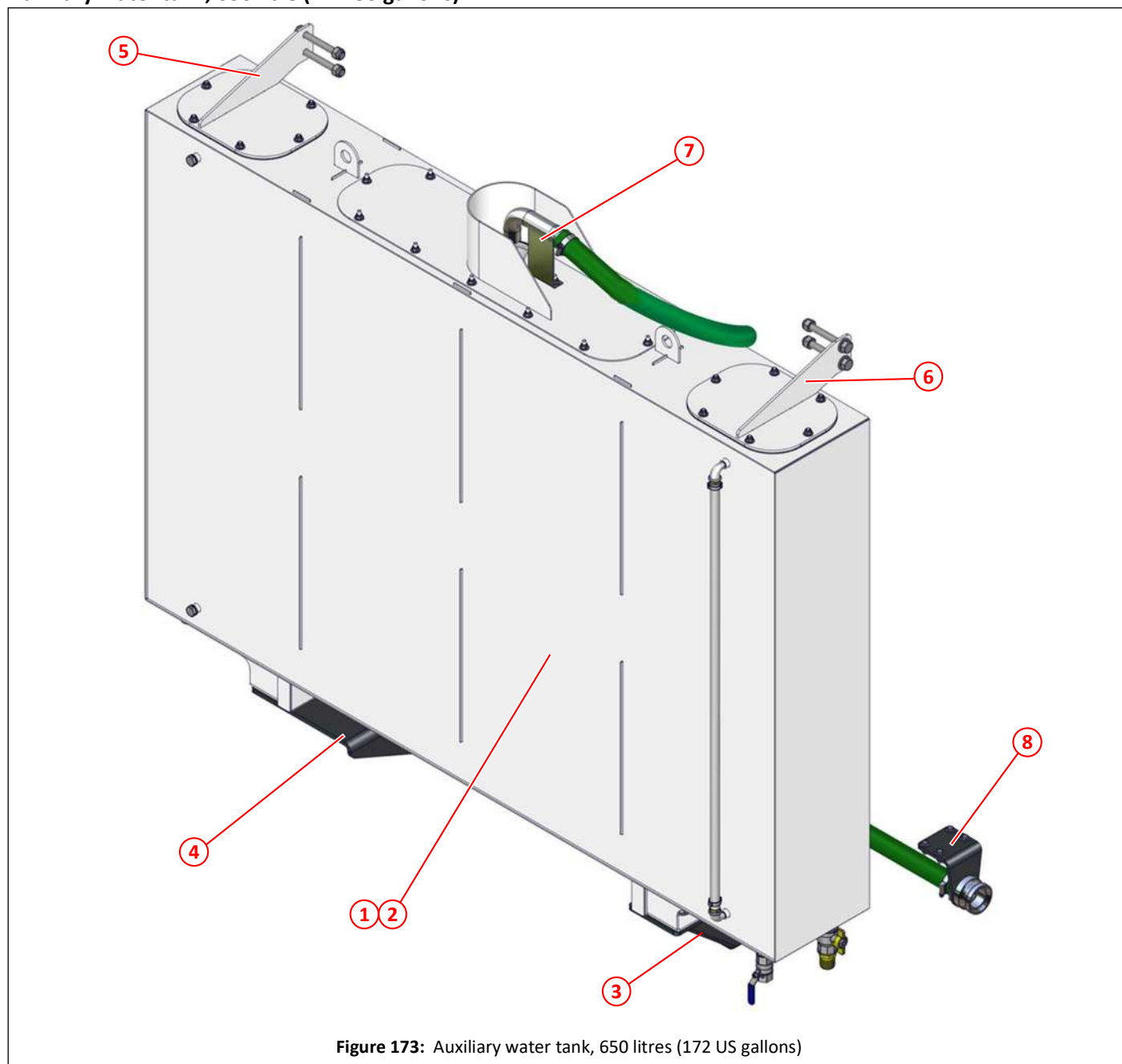

Figure 173: Auxiliary water tank, 650 litres (172 US gallons)

Item	Part No	Qty	Description
①	043134	1	Auxiliary water tank complete assembly without mounting brackets
②	043104	1	Auxiliary water tank, just the tank with no fittings
③	043135	1	Auxiliary water tank mounting bracket, left hand side
④	043136	1	Auxiliary water tank mounting bracket, right hand side
⑤	045153	1	Auxiliary water tank brace, right hand side
⑥	045154	1	Auxiliary water tank brace, left hand side
⑦	024586	1	Tank filler pipe
⑧			Hydrant filler

Auxiliary water tank, lower mounting brackets

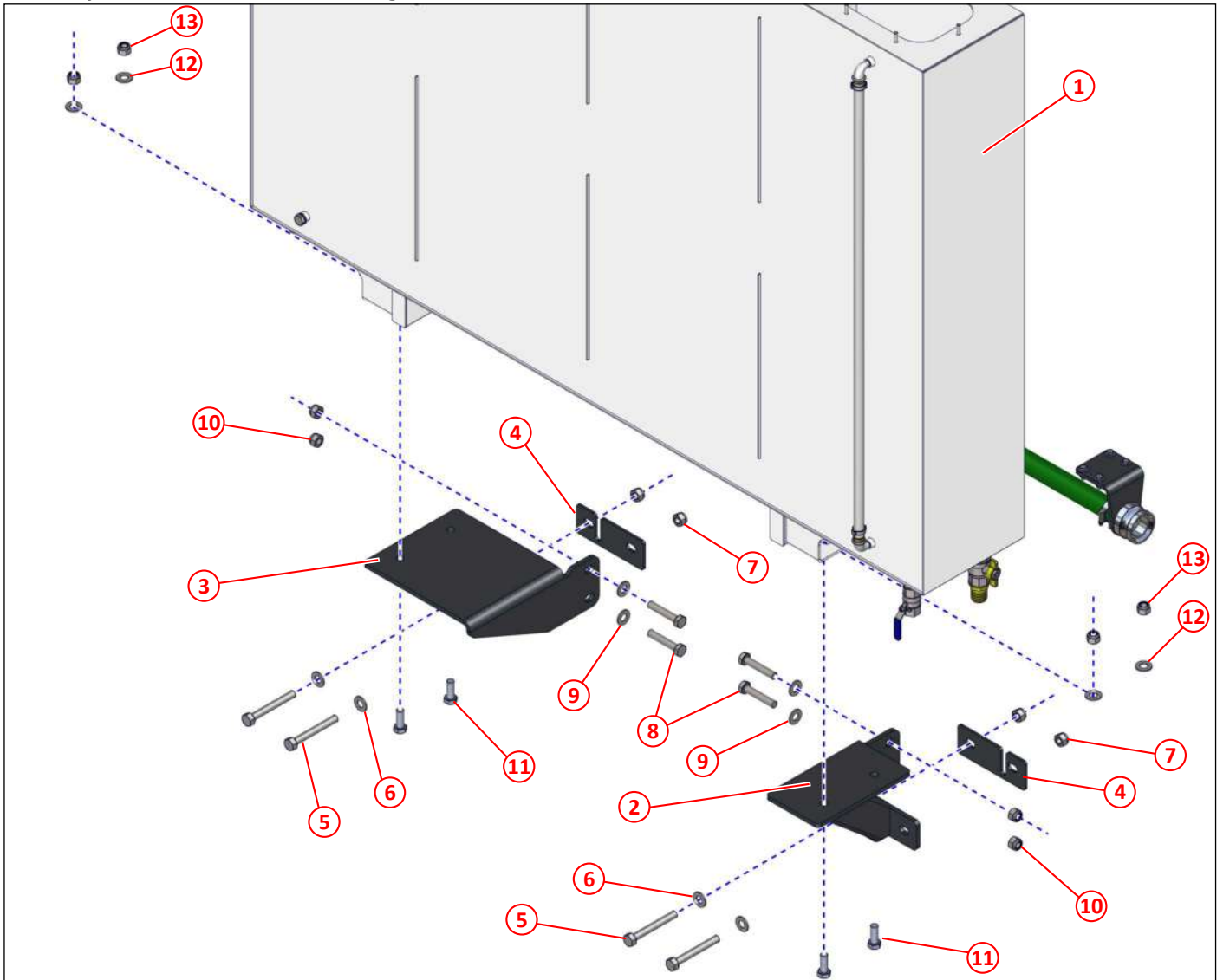

Figure 174: Auxiliary water tank, lower mounting brackets

Item	Part No	Qty	Description
①	043104	1	Auxiliary water tank, just the tank with no fittings
②	043135	1	Auxiliary water tank mounting bracket, left hand side
③	043136	1	Auxiliary water tank mounting bracket, right hand side
④	045127	2	Auxiliary water tank plate
⑤	000184	4	Bolt M16 x 120, Grade 10.9
⑥	011135	4	Plain washer M16
⑦	011060	4	Nyloc nut M16
⑧	011261	4	Bolt M16 x 80
⑨	011135	4	Plain washer M16
⑩	011060	4	Nyloc nut M16
⑪	000386	4	Bolt M16 x 40 x 1.5 pitch
⑫	011135	4	Plain washer M16
⑬	011060	4	Nyloc nut M16

Auxiliary water tank, upper mounting braces

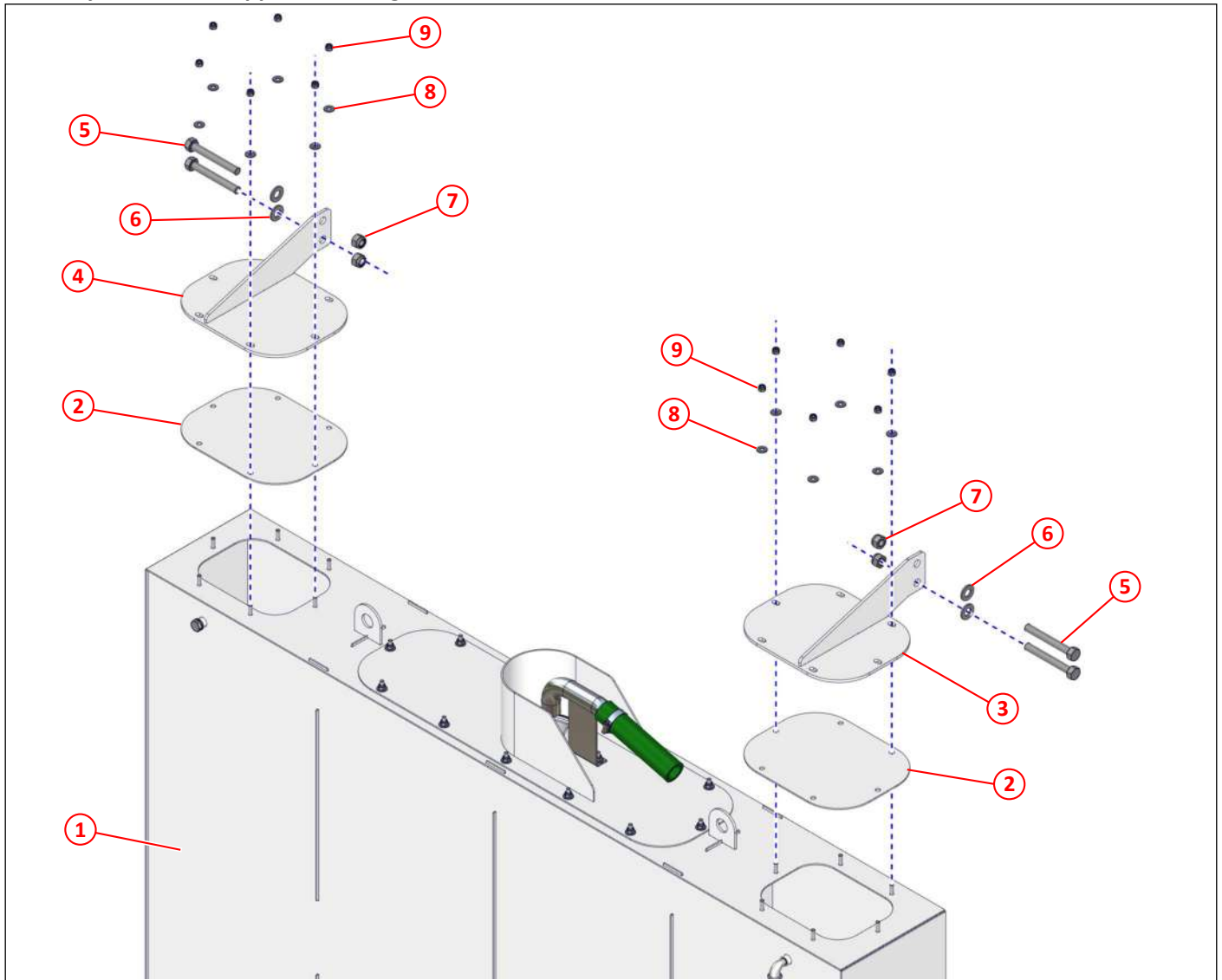

Figure 175: Auxiliary water tank, upper mounting braces

Item	Part No	Qty	Description
①	043104	1	Auxiliary water tank, just the tank with no fittings
②	039877	2	Small lid, auxiliary water tank
③	045153	1	Auxiliary water tank brace, right hand side
④	045154	1	Auxiliary water tank brace, left hand side
⑤	000184	4	Bolt M16 x 120, Grade 10.9
⑥	011135	4	Plain washer M16
⑦	011060	4	Nyloc nut M16
⑧	000264	12	Plain washer M8, stainless steel
⑨	000263	12	Nyloc nut M8, stainless steel
NI	020362	As req	Inseal strip 3 x 15. To be places under the lids.



Auxiliary water tank, filler lid

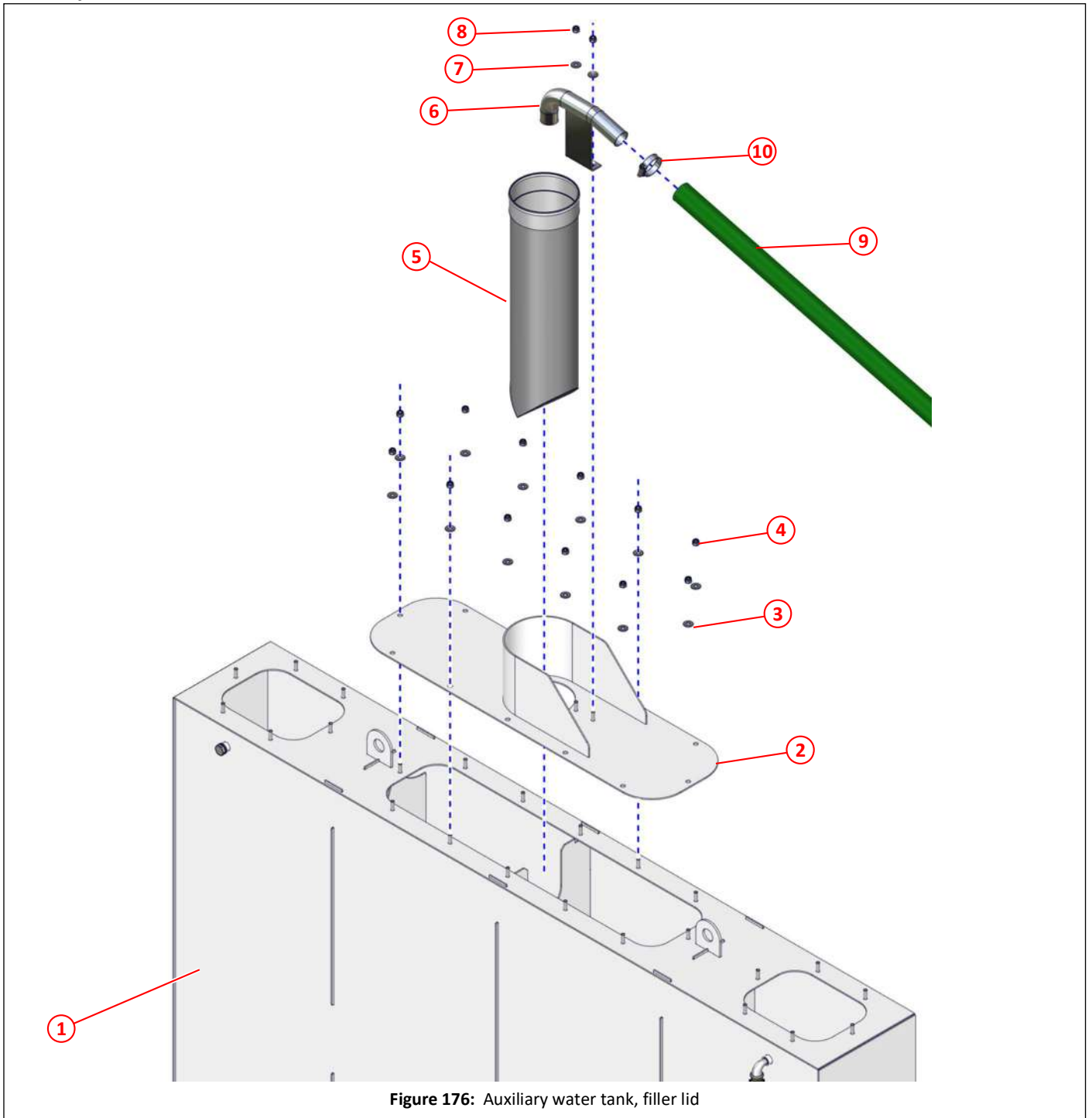

Figure 176: Auxiliary water tank, filler lid

Item	Part No	Qty	Description
①	043104	1	Auxiliary water tank, just the tank with no fittings
②	045151	2	Centre lid, auxiliary water tank
③	000264	12	Plain washer M8, stainless steel
④	000263	12	Nyloc nut M8, stainless steel
⑤	032461	1	Water tank strainer
⑥	024586	1	Hydrant filler pipe
⑦	000264	2	Plain washer M8, stainless steel
⑧	000263	2	Nyloc nut M8, stainless steel
⑨	001045	As req	Hose, green medium duty, id 1 ½"
⑩	003007	1	Hose clamp, worm drive, No. 2A (ø35-ø50]
NI	020362	As req	Inseal strip 3 x 15. To be places under the lid.

Auxiliary water tank, sight tube

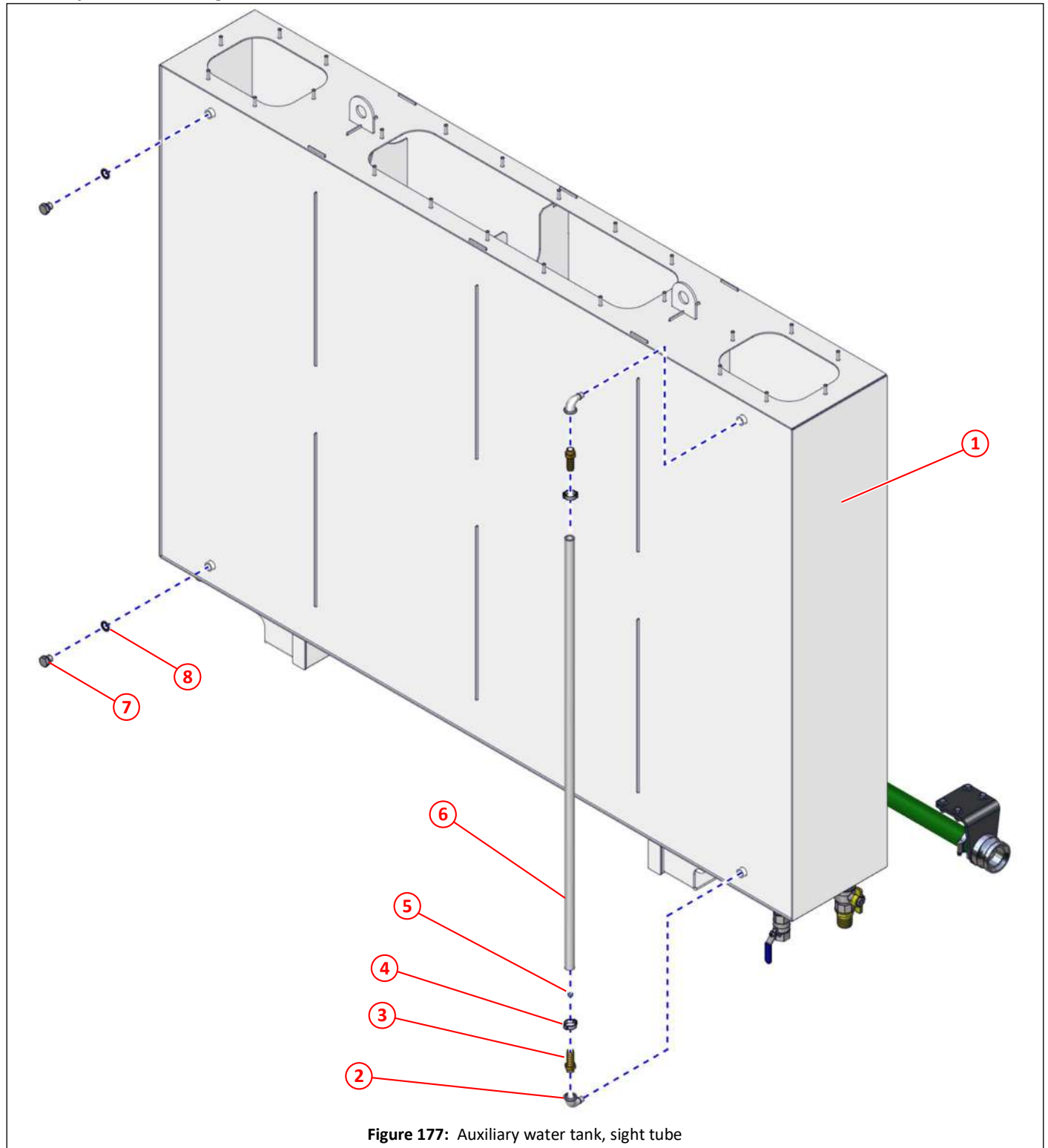

Figure 177: Auxiliary water tank, sight tube

Item	Part No	Qty	Description
①	043104	1	Auxiliary water tank, just the tank with no fittings
②	010913	2	Elbow, M/F, $\frac{3}{8}$ " BSP
③	010930	2	Adapter, $\frac{3}{8}$ " BSP x $\frac{5}{8}$ ", hose tail
④	000202	2	O-Clip $\frac{7}{8}$ "
⑤	025335	1	Ball, plastic, $\frac{1}{2}$ "
⑥	034465	1.5m	PVC tube, clear, $\frac{5}{8}$ "
⑦	011242	2	Plug, $\frac{3}{8}$ " BSP
⑧	011153	2	Dowty seal, $\frac{3}{8}$ " BSP

Auxiliary water tank, valve fittings

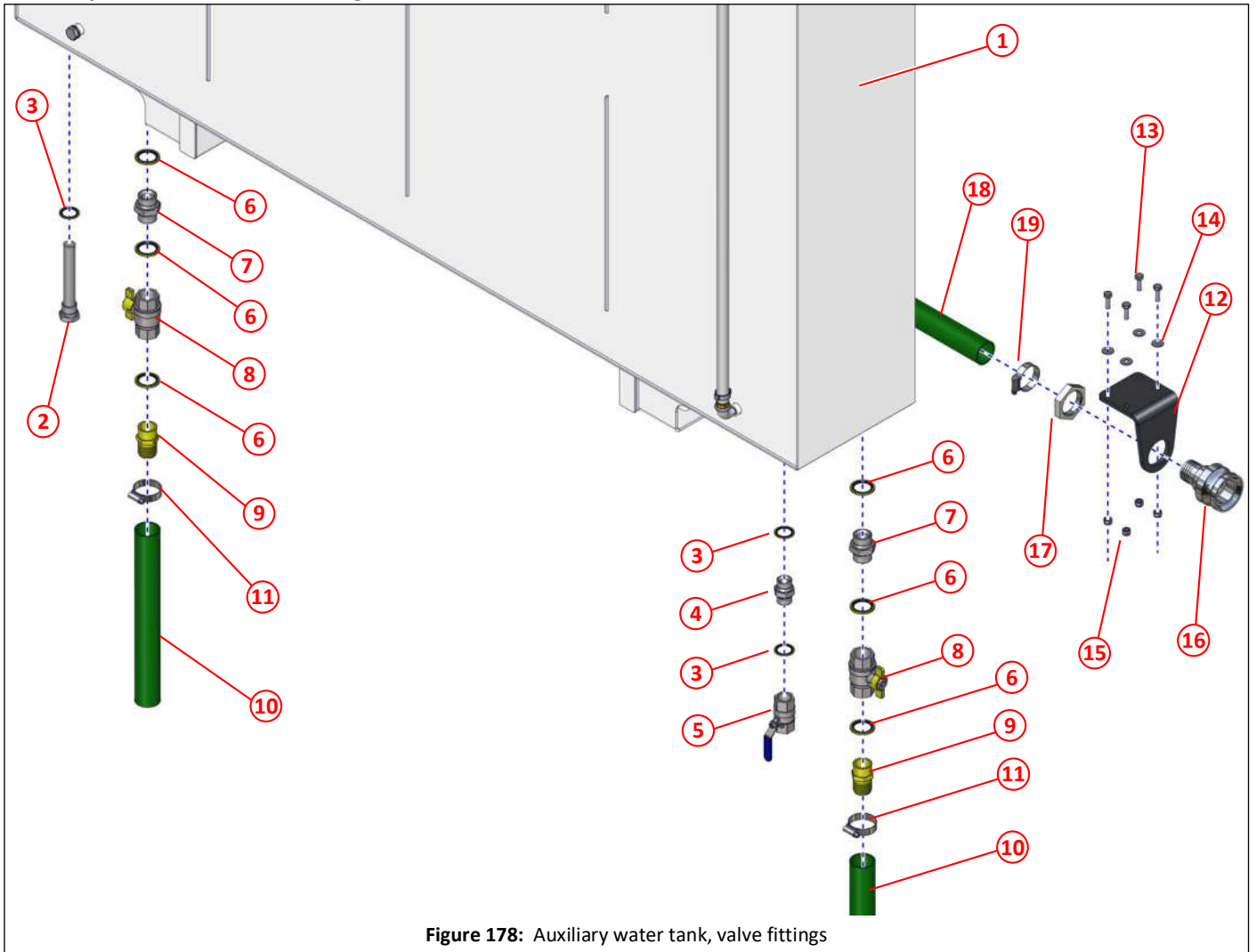

Figure 178: Auxiliary water tank, valve fittings

Item	Part No	Qty	Description
①	043104	1	Auxiliary water tank, just the tank with no fittings
②	012883	1	Sacrificial anode
③	011155	3	Dowty seal, 3/4" BSP
④	011161	1	Adapter, 3/4" BSP
⑤	013757	1	Valve, ball, 3/4" BSP
⑥	011156	6	Dowty seal, 1" BSP
⑦	011162	2	Adapter, 1" BSP
⑧	002050	2	Valve, ball, 1" BSP, low pressure
⑨	003029	2	Adapter, 1" BSP x 1 1/4" hose tail
⑩	001077	As req	Hose, green, medium duty, id 1 1/4"
⑪	003007	2	Hose clamp, worm drive, No. 2A (ø35-ø50]
⑫	039313	1	Adapter bracket
⑬	000257	4	Set screw M8 x 25, stainless steel
⑭	000264	4	Plain washer M8, stainless steel
⑮	000263		Nyloc nut M8, stainless steel
⑯	025140	1	Hydrant adapter
⑰	003026	1	Back nut, 1 1/2" BSP
⑱	001045	As req	Hose, green medium duty, id 1 1/2"
⑲	003007	2	Hose clamp, worm drive, No. 2A (ø35-ø50]

Water strainer, low pressure

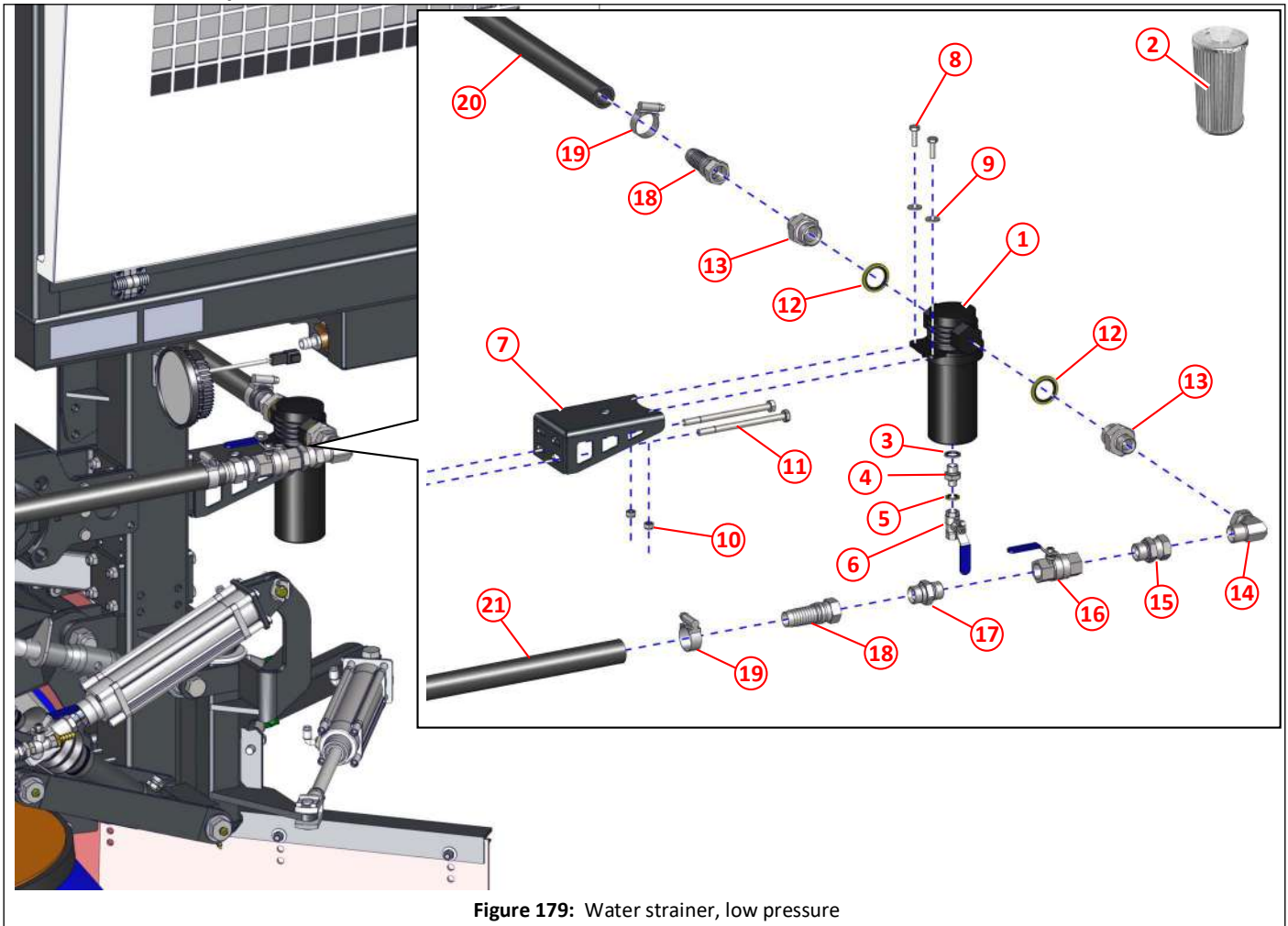

Figure 179: Water strainer, low pressure

Item	Part No	Qty	Description
①	023862	1	Water strainer, complete with filter element
②	023863	1	Filter element
③	011153	1	Dowty seal, $\frac{3}{8}$ " BSP
④	011199	1	Adapter, M/M, $\frac{3}{8}$ " BSP x $\frac{1}{4}$ " BSP
⑤	011152	1	Dowty seal, $\frac{1}{4}$ " BSP
⑥	011743	1	Valve, ball, $\frac{1}{4}$ " BSP
⑦	043086	1	Bracket, water strainer
⑧	011011	2	Set screw M8 x 25
⑨	011092	2	Plain washer M8
⑩	011073	2	Nyloc nut M8
⑪	000041	2	Bolt M10 x 140, part of low pressure water pump mounting
⑫	011156	2	Dowty seal 1" BSP
⑬	011193	2	Adapter, 1" BSP x $\frac{3}{4}$ " BSP
⑭	011174	1	Elbow, swivel, $\frac{3}{4}$ " BSP
⑮	012228	1	Adapter, swivel, M/F, $\frac{3}{4}$ " BSP
⑯	013757	1	Valve, ball, $\frac{3}{4}$ " BSP
⑰	011161	1	Adapter, $\frac{3}{4}$ " BSP
⑱	002084	2	Adapter, $\frac{3}{4}$ " BSP x 1" hose tail
⑲	010518	2	Hose clamp, worm drive, No. 1X (ø30-ø40)
⑳	010959	As req	Hose, 1", to water filter (to low pressure water pump)
㉑	010959	As req	Hose, 1", to water filter (from water tank)

Water pump, twin diaphragm, low pressure, mounting

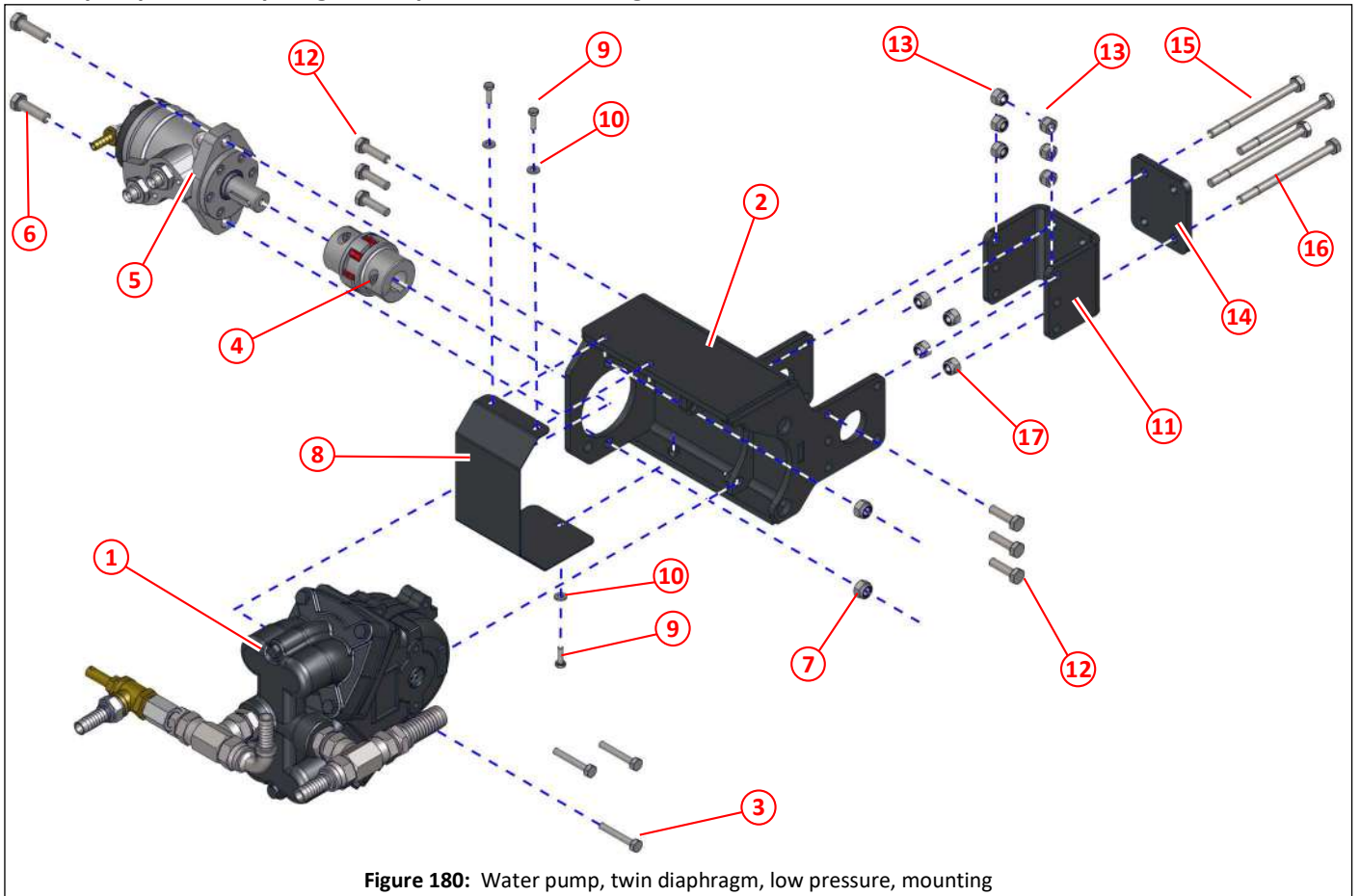

Figure 180: Water pump, twin diaphragm, low pressure, mounting

Item	Part No	Qty	Description	
①	010208	1	Water pump, twin diaphragm, low pressure	
②	045029	1	Mounting bracket, water pump, low pressure	
③	011016	3	Set screw M8 x 50	
④	043779	1	Coupling, water pump	
⑤	043778	1	Hydraulic motor 40cc	278
⑥	011069	2	Bolt M12 x 40	
⑦	011077	2	Nyloc nut M12	
⑧	044186	1	Cover, coupling	
⑨	011067	3	Set screw M6 x 20	
⑩	011090	3	Plain washer M6	
⑪	045030	1	Adapter plate	
⑫	011033	6	Set screw M10 x 35	
⑬	011075	6	Nyloc nut M10	
⑭	045031	1	Spreader plate	
⑮	000075	2	Bolt M10 x 130	
⑯	000041	2	Bolt M10 x 140	
⑰	011075	4	Nyloc nut M10	

Water pump, twin diaphragm, low pressure, fittings

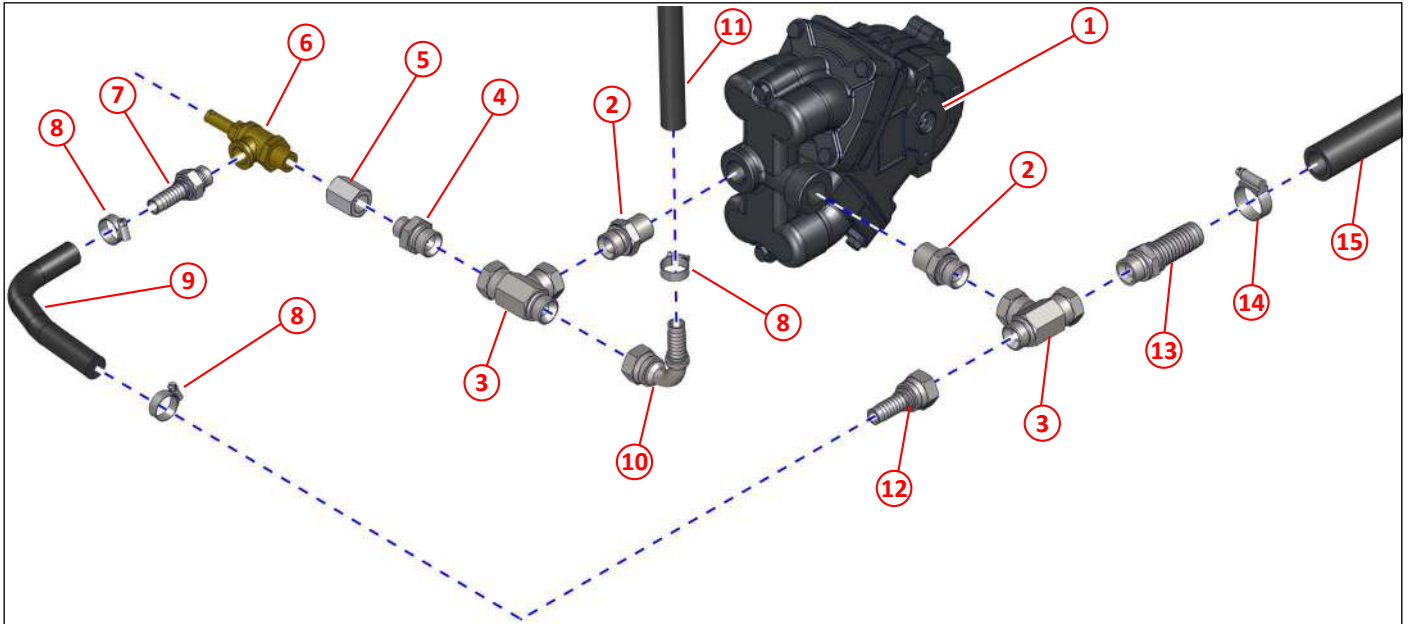

Figure 181: Water pump, twin diaphragm, low pressure, fittings

Item	Part No	Qty	Description
①	010208	1	Water pump, twin diaphragm, low pressure
②	002245	2	Adapter, M/M, 3/4" BSPP x 3/4" BSPT
③	002233	2	Tee, M/F/F, nuts on branch, 3/4" BSP
④	011166	1	Adapter, 3/4" BSP x 1/2" BSP
⑤	010900	1	Socket 1/2" BSP
⑥	045532	1	Valve, pressure regulating (13.8 bar)
⑦	002159	1	Adapter, male 3/4" BSPP x 5/8" hose tail
⑧	010517	3	Hose clamp, worm drive, No. 0X (ø18-ø25)
⑨	011000	As req	Hose, 5/8", pressure relief
⑩	001145	1	Elbow, female 3/4" BSP x 5/8" hose tail
⑪	011000	As req	Hose, 5/8", to water valves
⑫	001144	1	Adapter, female 3/4" BSPP x 5/8" hose tail
⑬	002252	1	Adapter, male 3/4" BSPP x 1" hose tail
⑭	010518	1	Hose clamp, worm drive, No. 1X (ø30-ø40)
⑮	010959	As req	Hose 1", from water strainer, low pressure



Water pump, twin diaphragm, low pressure, components

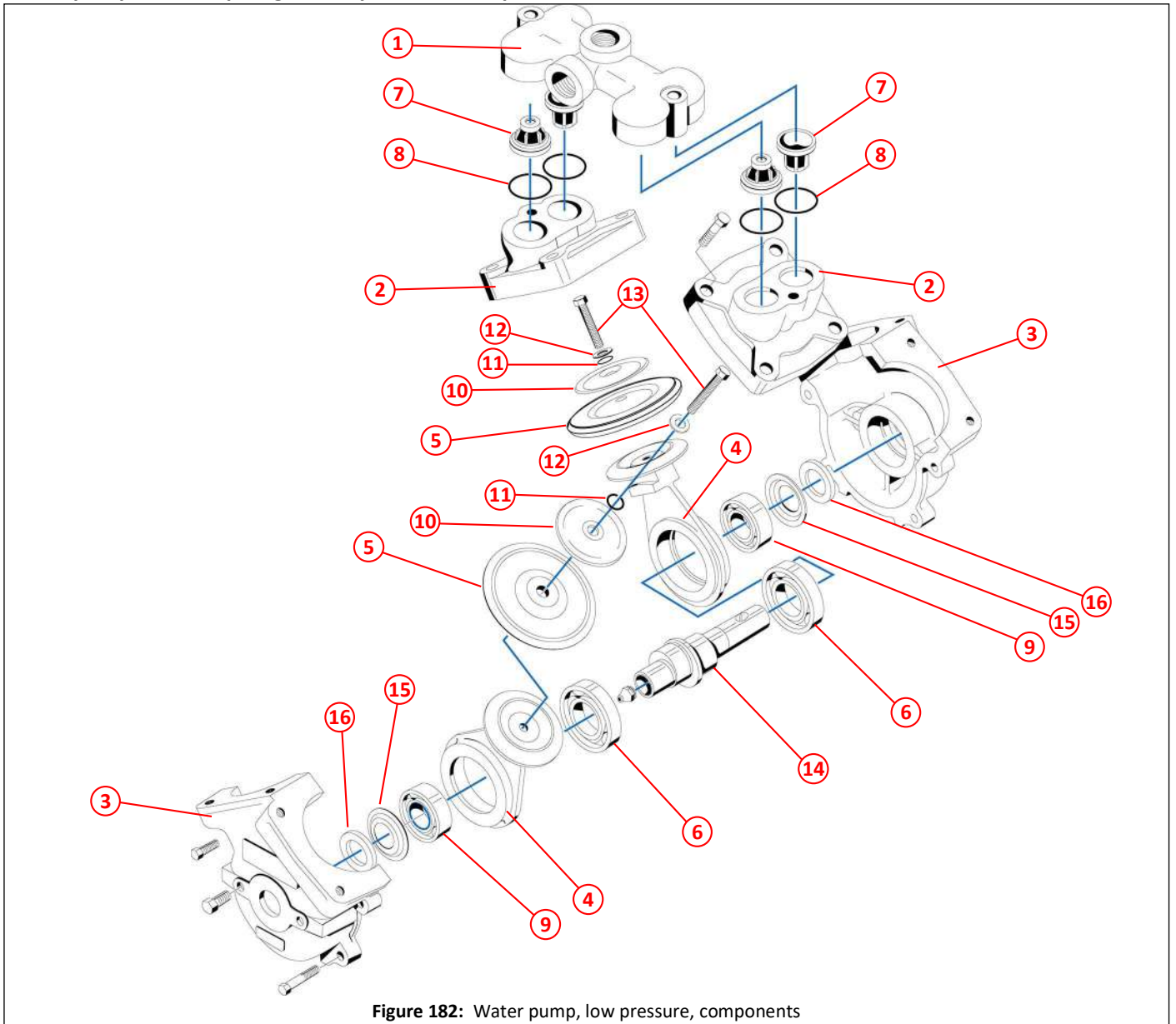
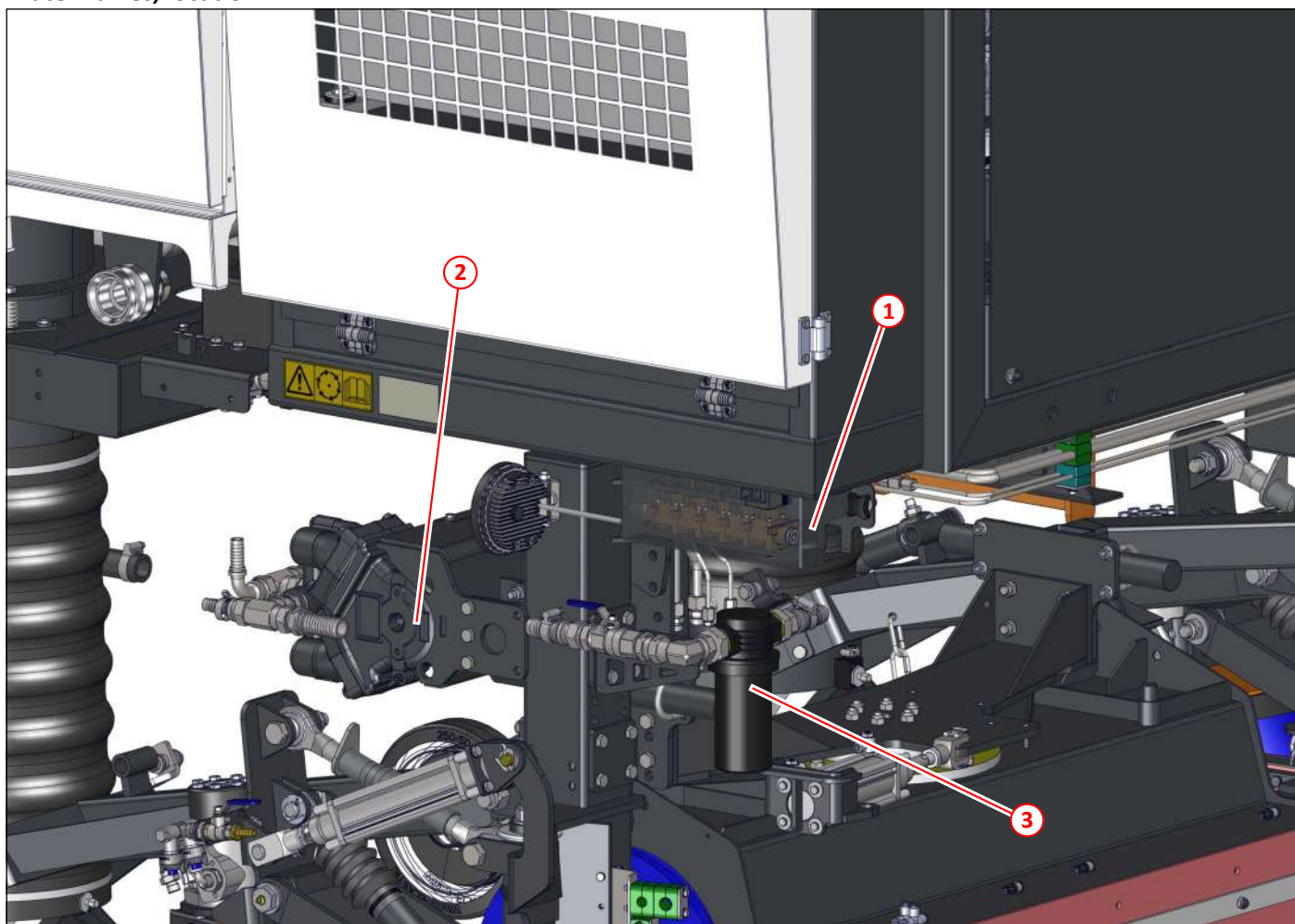

Figure 182: Water pump, low pressure, components

Item	Part No	Qty	Description
①	020460	1	Pump bridge, valve chamber
②	020463	2	Pump head, diaphragm cover
③	020461	2	Pump crankcase
④	014682	2	Connecting rod
⑤	013629	2	Diaphragm
⑥	TBC	2	Bearing, ball
⑦	013627	4	Poppet valve
⑧	013628	4	Sealing ring
⑨	TBC	2	Bearing, ball
⑩	014882	2	Diaphragm upper
⑪	031560	2	Seal
⑫	031561	2	Washer
⑬	TBC	2	Bolt
⑭	TBC	1	Pump eccentric
⑮	014881	2	Retainer
⑯	014879	2	Felt washer
⑰	010903	1	Grease nipple, 1/8" straight

Water valves, location



**i** Cover of the water valves ghosted.

Figure 183: Water valves, location

Item	Part No	Qty	Description	
①			Water valves	219,221,222,223,224
②		1	Water pump, twin diaphragm, low pressure	215
③		1	Water strainer, complete with filter element	214

Water valves, 2-way, mounting

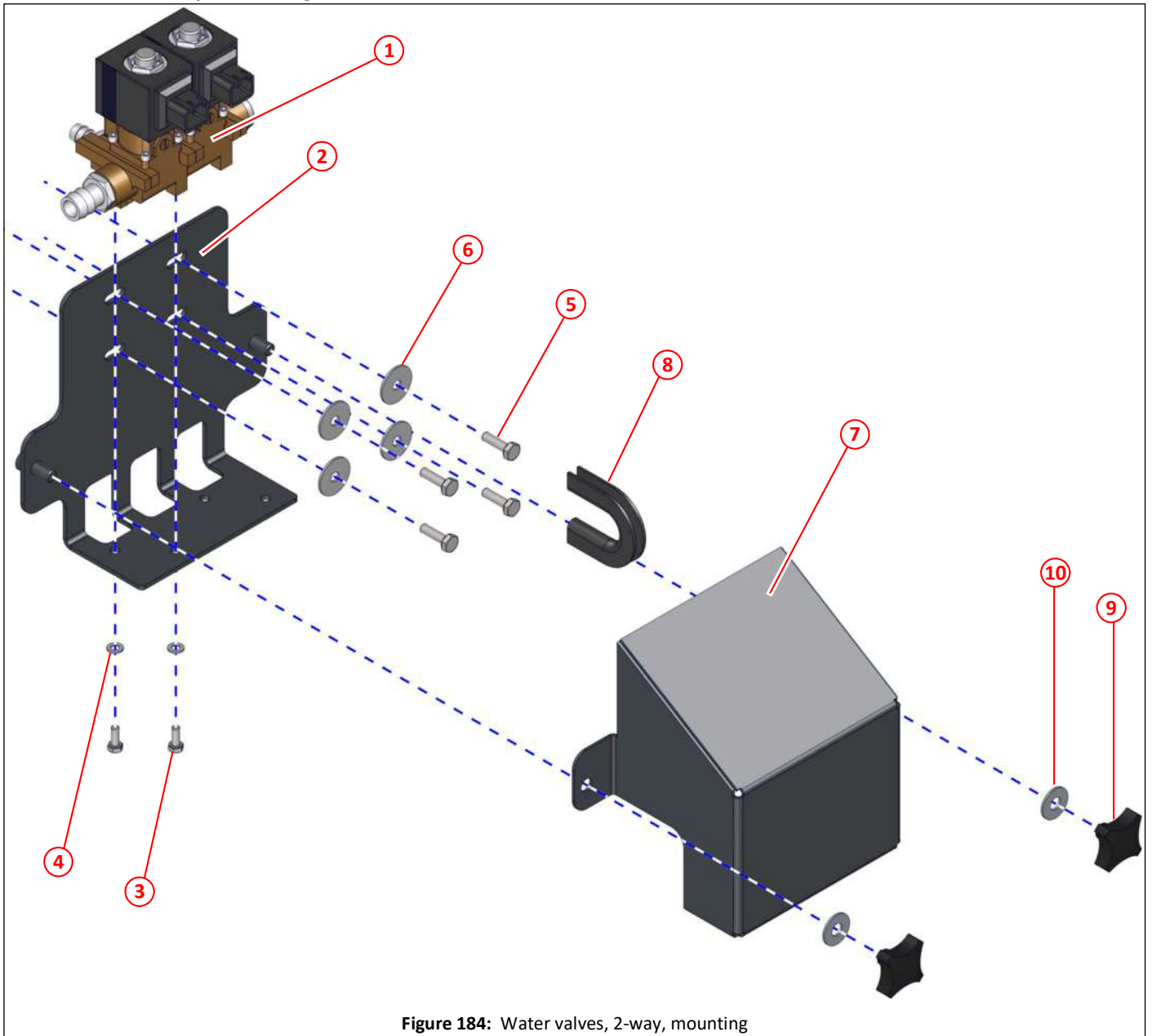

Figure 184: Water valves, 2-way, mounting

Item	Part No	Qty	Description	
①	043113	1	Water valve, 2 valve assembly, 24v	224
①	TBA	1	Water valve, 2 valve assembly, 12v	224
②	038384	1	Mounting bracket, water valves	
③	000097	2	Bolt M5 x 12	
④	000410	2	Plain washer M5	
⑤	011067	4	Set screw M6 x 20	
⑥	011099	4	Repair washer $\phi\frac{1}{4}$ " x $\phi 1$ "	
⑦	043366	1	Cover, water valves	
⑧	005073	As req	Titanfast edging MET106 to suit 3-5mm	
⑨	000248	2	Grip nut M8	
⑩	011092	2	Plain washer M8	

Water valves, 3-way, mounting

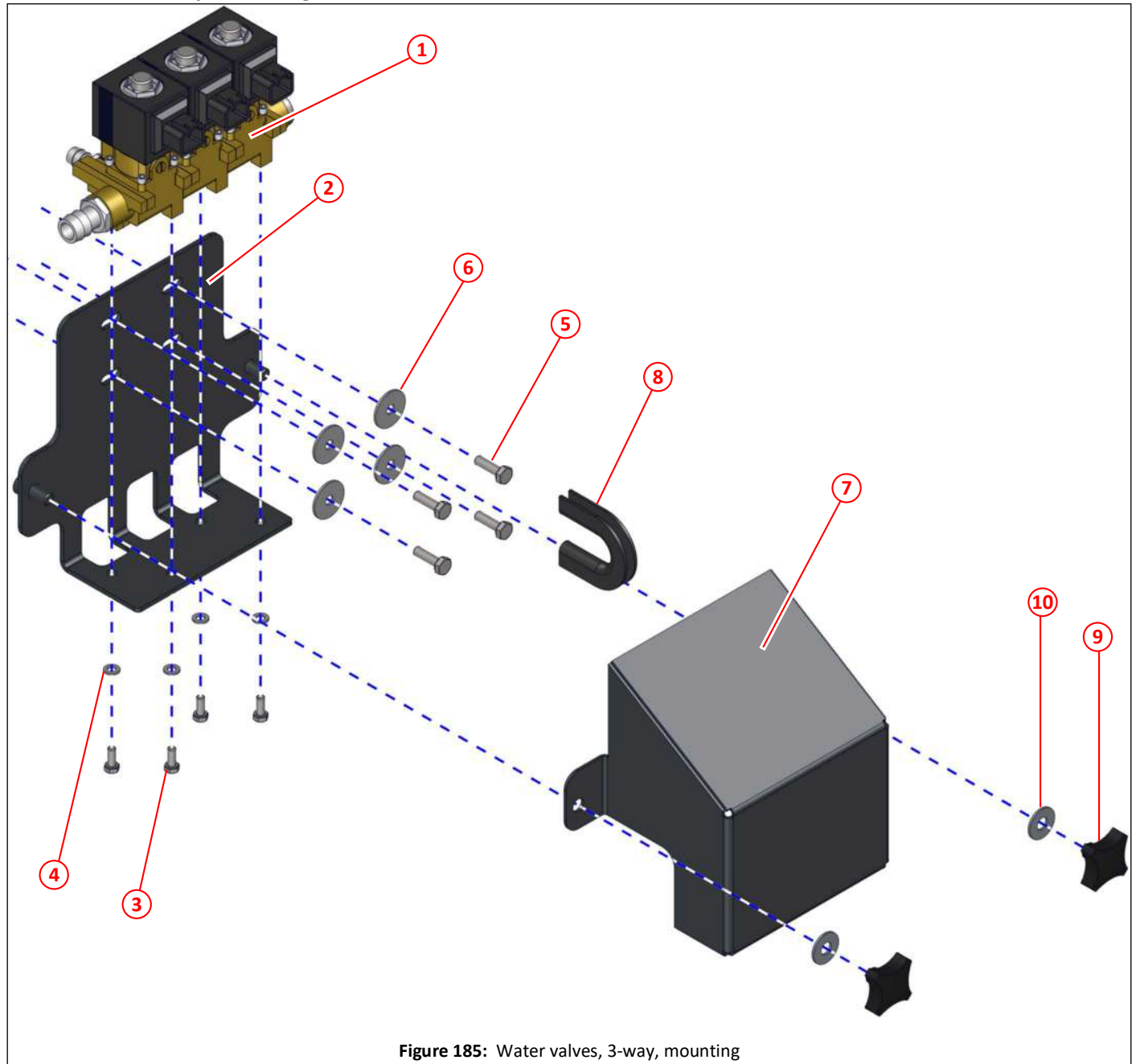

Figure 185: Water valves, 3-way, mounting

Item	Part No	Qty	Description	
①	038370	1	Water valve, 3 valve assembly, 24v	224
①	038369	1	Water valve, 3 valve assembly, 12v	224
②	038384	1	Mounting bracket, water valves	
③	000097	4	Bolt M5 x 12	
④	000410	4	Plain washer M5	
⑤	011067	4	Set screw M6 x 20	
⑥	011099	4	Repair washer $\phi\frac{1}{4}$ " x $\phi 1$ "	
⑦	043366	1	Cover, water valves	
⑧	005073	As req	Titanfast edging MET106 to suit 3-5mm	
⑨	000248	2	Grip nut M8	
⑩	011092	2	Plain washer M8	

Water valves, 4-way, mounting

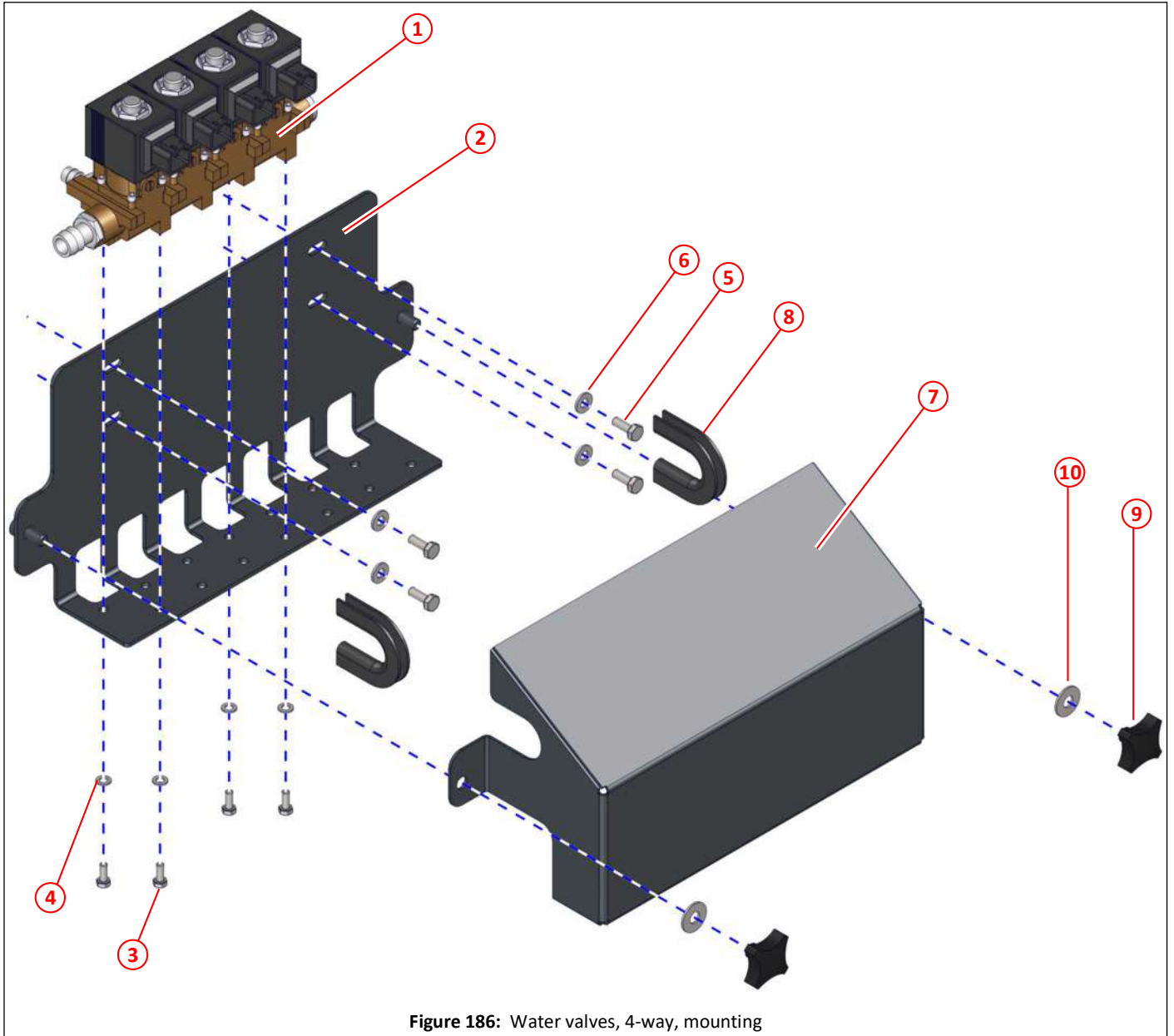

Figure 186: Water valves, 4-way, mounting

Item	Part No	Qty	Description	
①	043641	1	Water valve, 4 valve assembly, 24v	224
①	044662	1	Water valve, 4 valve assembly, 12v	224
②	043365	1	Mounting bracket, water valves	
③	000097	4	Bolt M5 x 12	
④	000410	4	Plain washer M5	
⑤	011001	4	Set screw M6 x 16	
⑥	011090	4	Plain washer M6	
⑦	043366	1	Cover, water valves	
⑧	005073	As req	Titanfast edging MET106 to suit 3-5mm	
⑨	000248	2	Grip nut M8	
⑩	011092	2	Plain washer M8	



Water valves, 5-way, mounting

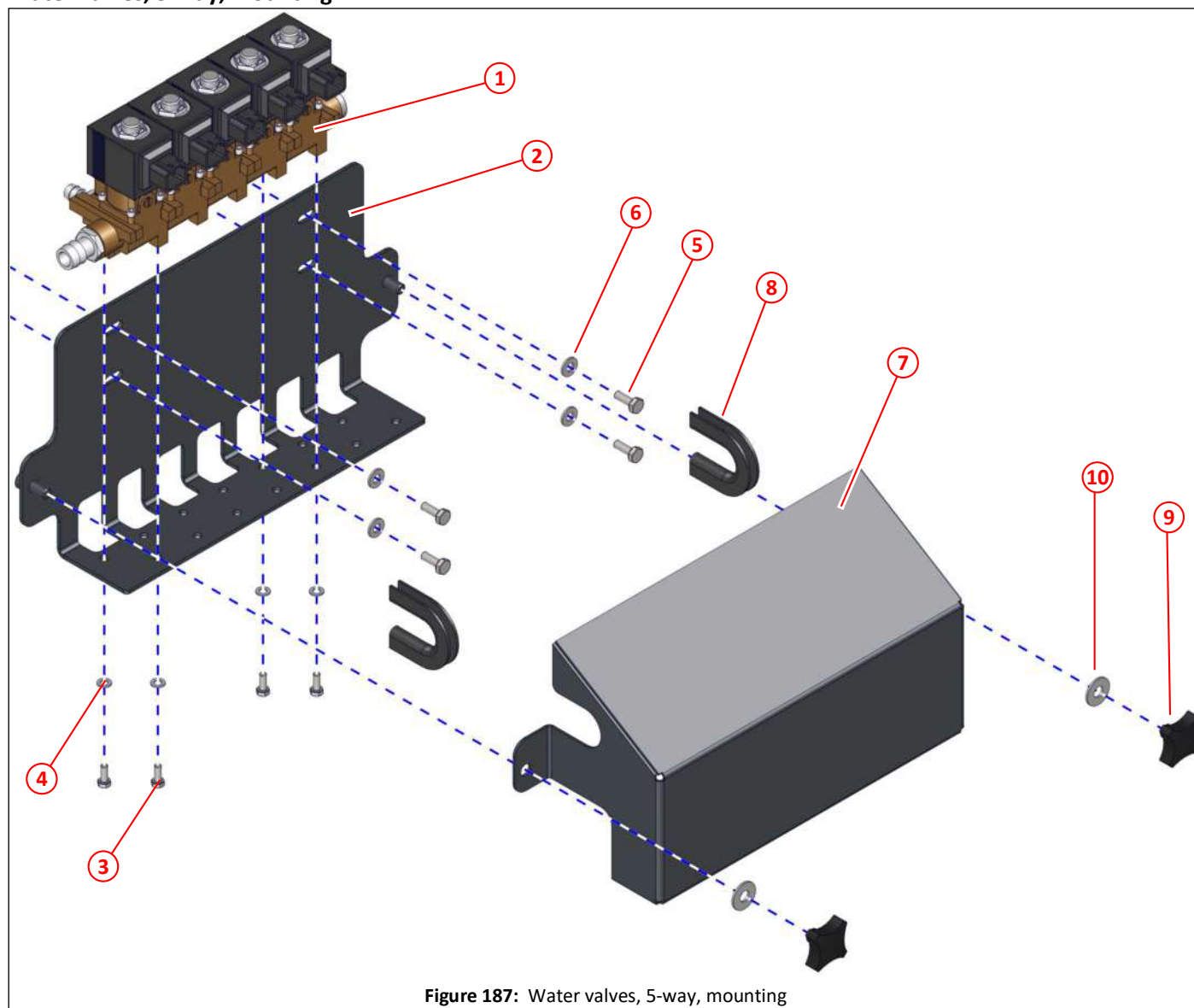

Figure 187: Water valves, 5-way, mounting

Item	Part No	Qty	Description	
①	043642	1	Water valve, 5 valve assembly, 24v	224
①	044493	1	Water valve, 5 valve assembly, 12v	224
②	043365	1	Mounting bracket, water valves	
③	000097	4	Bolt M5 x 12	
④	000410	4	Plain washer M5	
⑤	011001	4	Set screw M6 x 16	
⑥	011090	4	Plain washer M6	
⑦	043366	1	Cover, water valves	
⑧	005073	As req	Titanfast edging MET106 to suit 3-5mm	
⑨	000248	2	Grip nut M8	
⑩	011092	2	Plain washer M8	



Water valves, 6-way, mounting

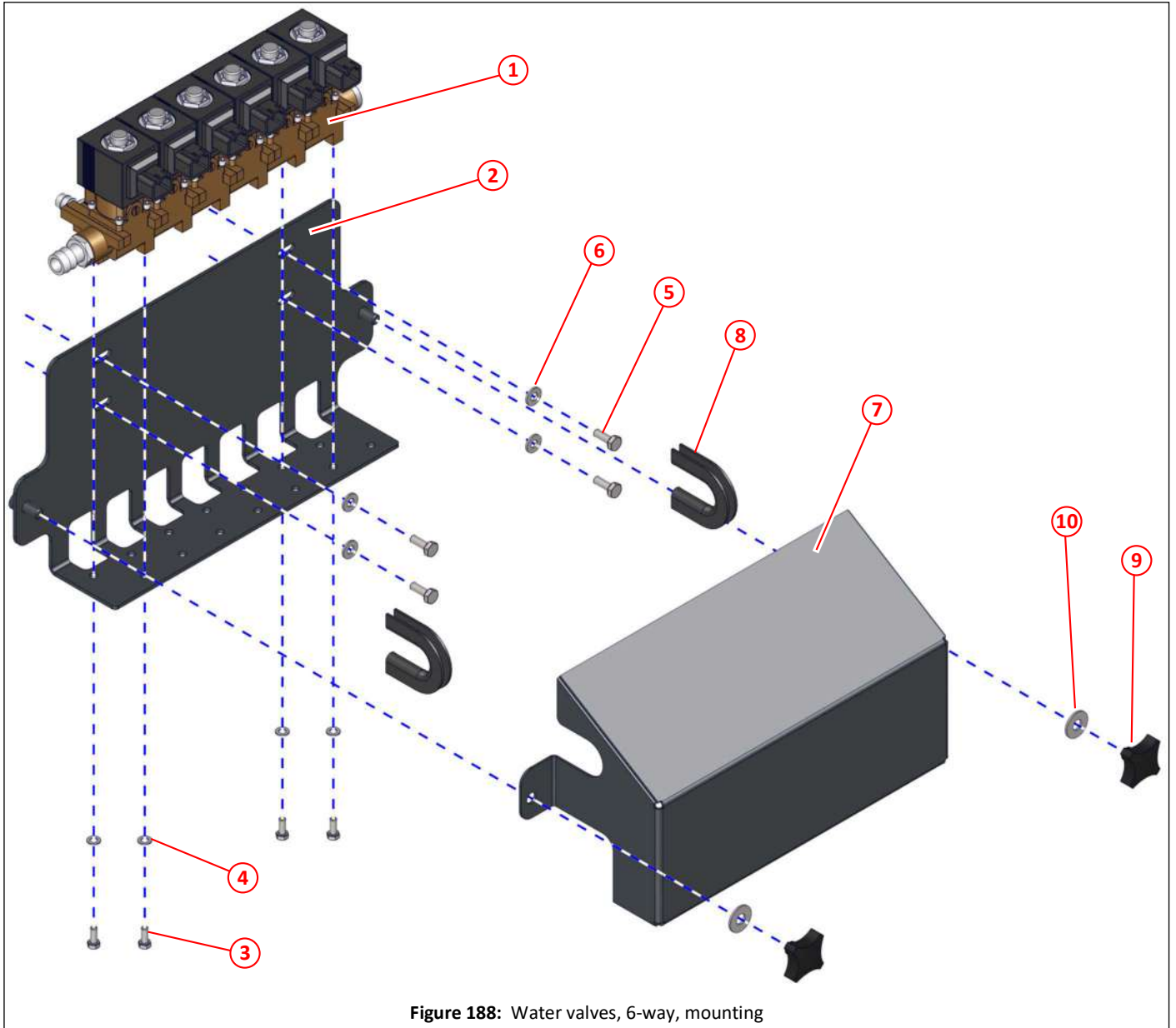
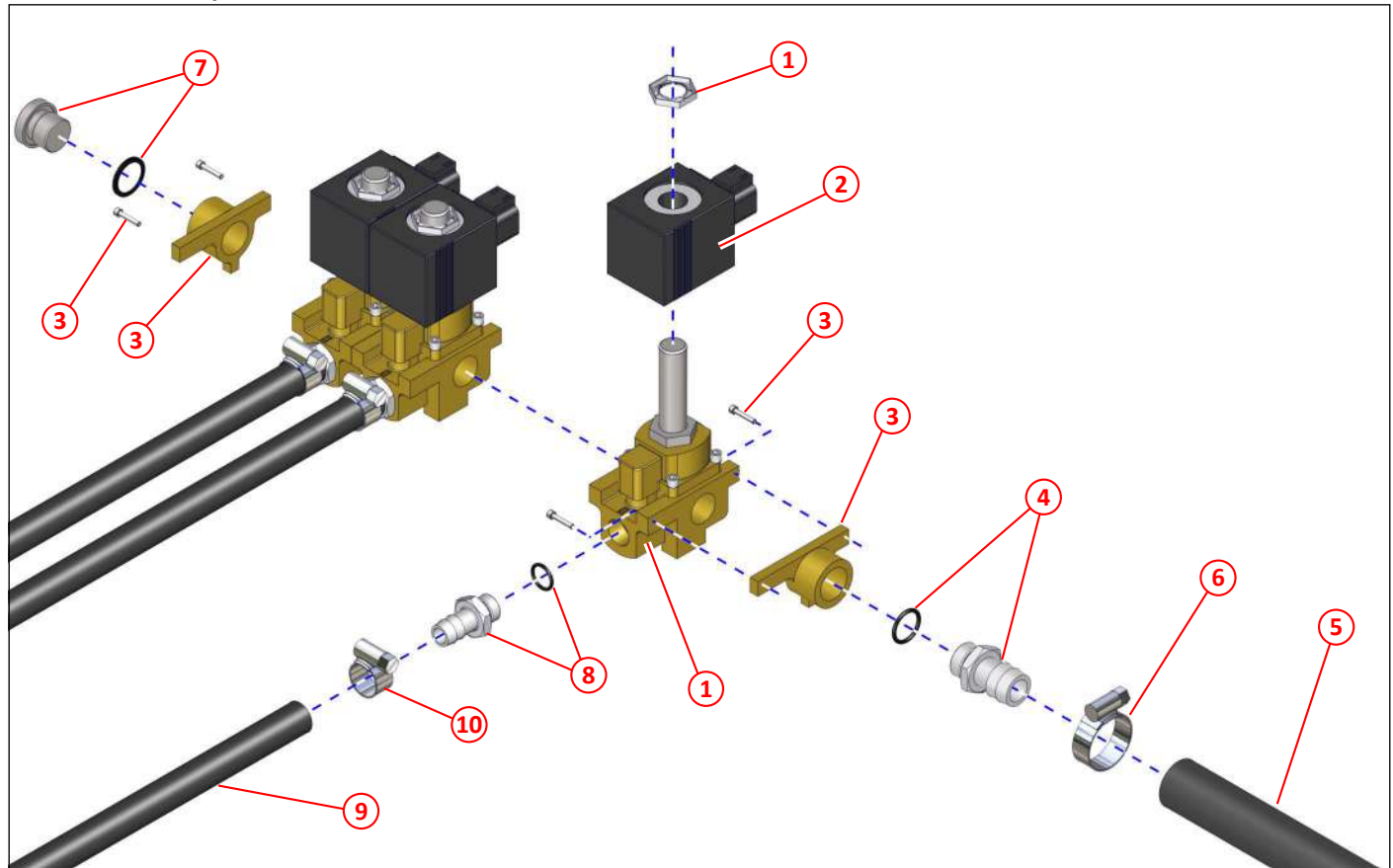

Figure 188: Water valves, 6-way, mounting

Item	Part No	Qty	Description	
①	043643	1	Water valve, 6 valve assembly, 24v	224
①	TBA	1	Water valve, 6 valve assembly, 12v	224
②	043365	1	Mounting bracket, water valves	
③	000097	4	Bolt M5 x 12	
④	000410	4	Plain washer M5	
⑤	011001	4	Set screw M6 x 16	
⑥	011090	4	Plain washer M6	
⑦	043366	1	Cover, water valves	
⑧	005073	As req	Titanfast edging MET106 to suit 3-5mm	
⑨	000248	2	Grip nut M8	
⑩	011092	2	Plain washer M8	

Water valve components



**i** 3 way water valve shown, other versions similar.

Figure 189: Water valve components

Item	Part No	Qty	Description
①	037969	As req	Water solenoid valve, Deutsch connector, includes item ②, 24v
①	038368	As req	Water solenoid valve, Deutsch connector, includes item ②, 12v
②	037059	As req	Coil, 8 watt, Deutsch connector, 24v
②	038371	As req	Coil, 8 watt, Deutsch connector, 12v
③	045753	1	Service kit, water valve, includes end pieces, screws and o-rings
④	TBC *	1	Adapter $\frac{3}{8}$ " BSP x 17mm hose tail, with rubber seal
⑤	011000	As req	Hose $\frac{5}{8}$ "
⑥	010517	1	Hose clamp, worm drive, No. 0X ( $\phi$ 18mm- $\phi$ 25mm)
⑦	TBC †	1	Plug $\frac{3}{8}$ " BSP, with rubber seal
⑧	TBC ‡	1	Adapter $\frac{1}{4}$ " BSP x 12mm hose tail, with rubber seal
⑨	010950	As req	Hose $\frac{3}{8}$ "
⑩	010516	1	Hose clamp, worm drive, No. M00 ( $\phi$ 11mm- $\phi$ 16mm)

\*. Use 010930 Adapter  $\frac{3}{8}$ " BSP x  $\frac{5}{8}$ " hose tail and 011153 Dowty seal  $\frac{3}{8}$ " BSP as an alternative

†. Use 011242 Plug  $\frac{3}{8}$ " BSP and 011153 Dowty seal  $\frac{3}{8}$ " BSP as an alternative

‡. Use 010922 Adapter  $\frac{1}{4}$ " BSP x  $\frac{3}{8}$ " hose tail and 011152 Dowty seal  $\frac{1}{4}$ " BSP as an alternative

Water spray nozzle, twin, left hand side brush

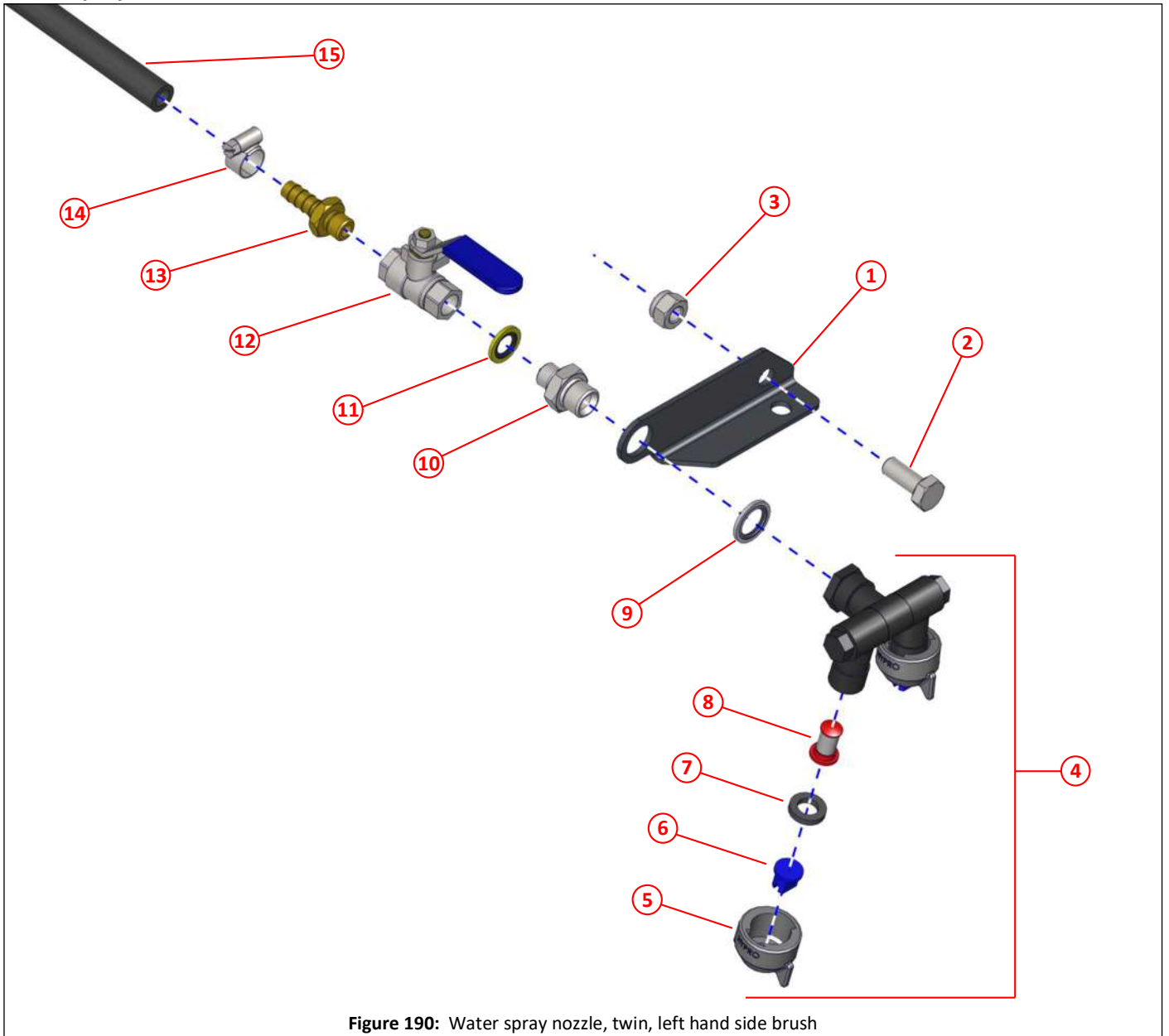

Figure 190: Water spray nozzle, twin, left hand side brush

Item	Part No	Qty	Description
①	036042	1	Nozzle bracket, twin nozzles, side brush, for left hand side
②	011031	1	Set screw M10 x25
③	011075	1	Nyloc nut M10
④	036044	1	Double swivel nozzle assembly
⑤	030635	1	Cone nozzle cap, per nozzle
⑥	030748	1	Jet (blue), per nozzle
⑦	030636	1	Rubber washer, per nozzle
⑧	030633	1	Filter, 100 mesh, per nozzle
⑨	011153	1	Dowty seal $\frac{3}{8}$ " BSP
⑩	011199	1	Adapter $\frac{3}{8}$ " x $\frac{1}{4}$ " BSP
⑪	011152	1	Dowty seal $\frac{1}{4}$ " BSP
⑫	011743	1	Valve, ball, $\frac{1}{4}$ " BSP
⑬	010922	1	Adapter $\frac{1}{4}$ " BSP x $\frac{3}{8}$ " hose tail
⑭	010516	1	Hose clamp, worm drive, No. M00 ( $\phi$ 11mm- $\phi$ 16mm)
⑮	010950	As req	Hose $\frac{3}{8}$ "

Water spray nozzle, twin, right hand side brush

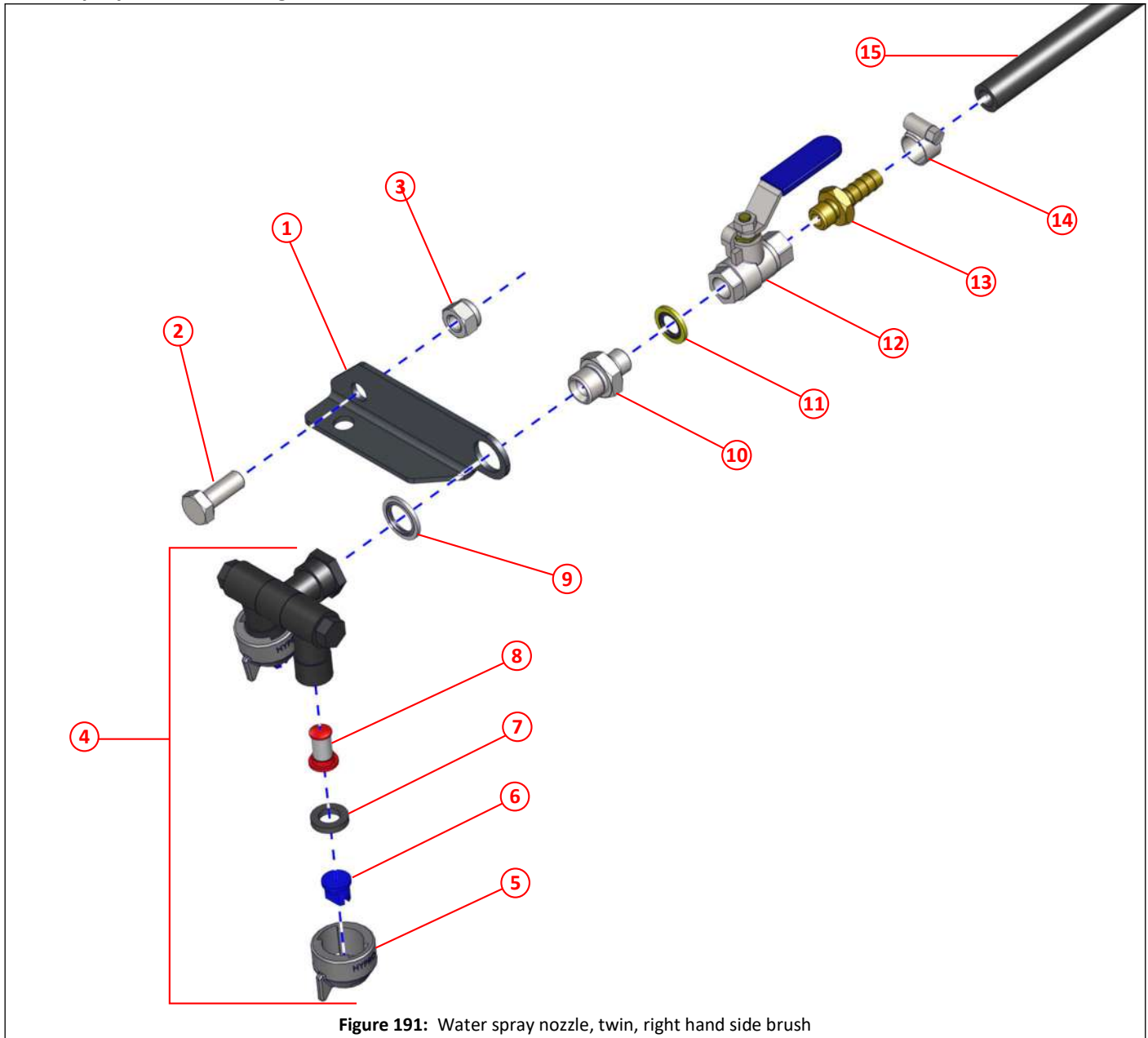

Figure 191: Water spray nozzle, twin, right hand side brush

Item	Part No	Qty	Description
①	036043	1	Nozzle bracket, twin nozzles, side brush, for right hand side
②	011031	1	Set screw M10 x25
③	011075	1	Nyloc nut M10
④	036044	1	Double swivel nozzle assembly
⑤	030635	1	Cone nozzle cap, per nozzle
⑥	030748	1	Jet (blue), per nozzle
⑦	030636	1	Rubber washer, per nozzle
⑧	030633	1	Filter, 100 mesh, per nozzle
⑨	011153	1	Dowty seal $\frac{3}{8}$ " BSP
⑩	011199	1	Adapter $\frac{3}{8}$ " x $\frac{1}{4}$ " BSP
⑪	011152	1	Dowty seal $\frac{1}{4}$ " BSP
⑫	011743	1	Valve, ball, $\frac{1}{4}$ " BSP
⑬	010922	1	Adapter $\frac{1}{4}$ " BSP x $\frac{3}{8}$ " hose tail
⑭	010516	1	Hose clamp, worm drive, No. M00 (ø11mm-ø16mm)
⑮	010950	As req	Hose $\frac{3}{8}$ "

Water spray nozzles, suction nozzle box

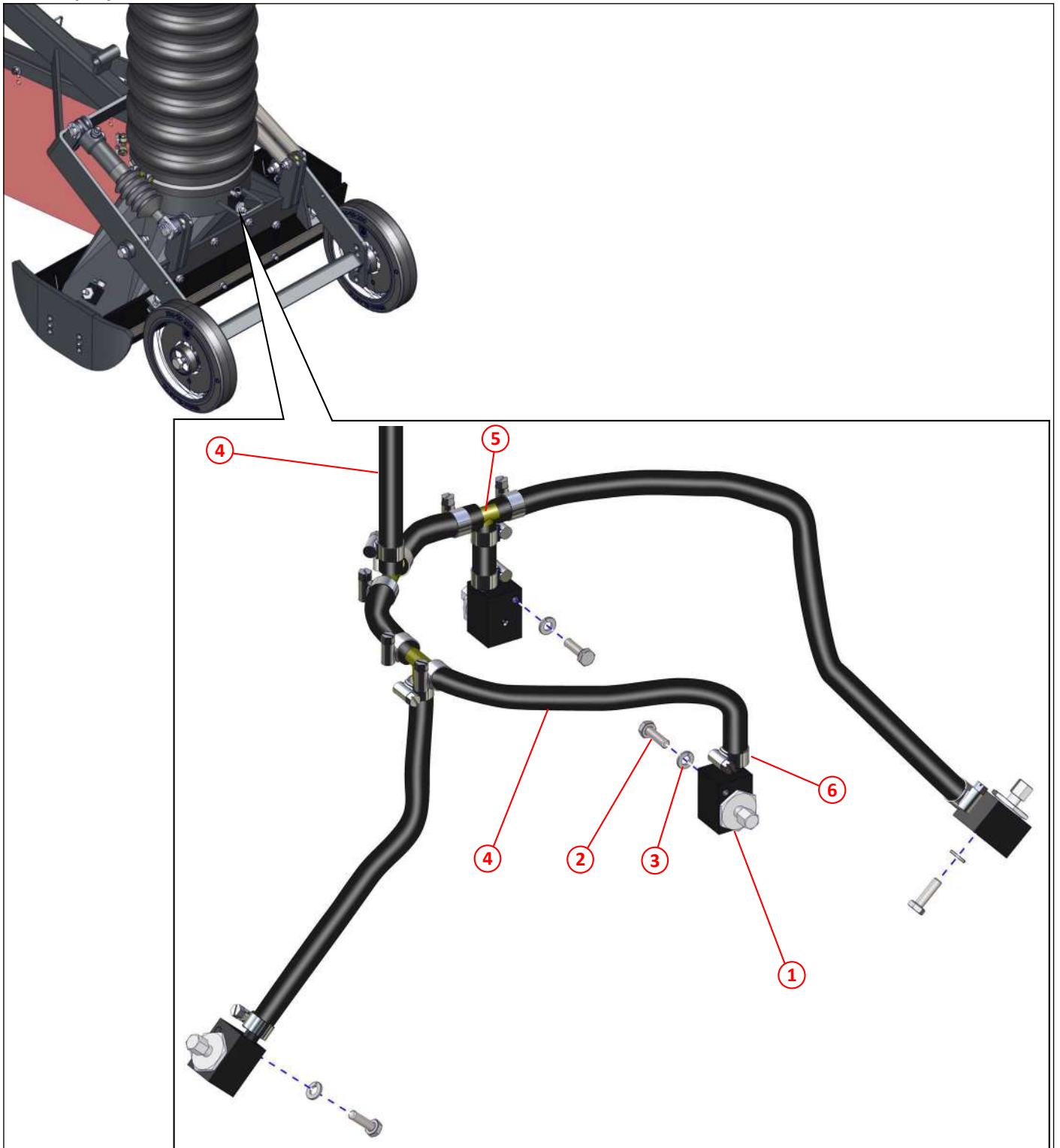

Figure 192: Water spray nozzles, suction nozzle box

Item	Part No	Qty	Description
①	013360 *	4	Spray jet, square block
②	011067 *	4	Set screw M6 x 20
③	011091 *	4	Spring washer M6
④	010950 *	As req	Hose $\frac{3}{8}$ "
⑤	003000 *	3	Tee, brass, equal. $\frac{3}{8}$ "
⑥	010516	13	Hose clamp, worm drive, No. M00 ( $\phi$ 11mm- $\phi$ 16mm)

\*. Quantities shown are per suction nozzle

Water spray nozzles, suction spigot

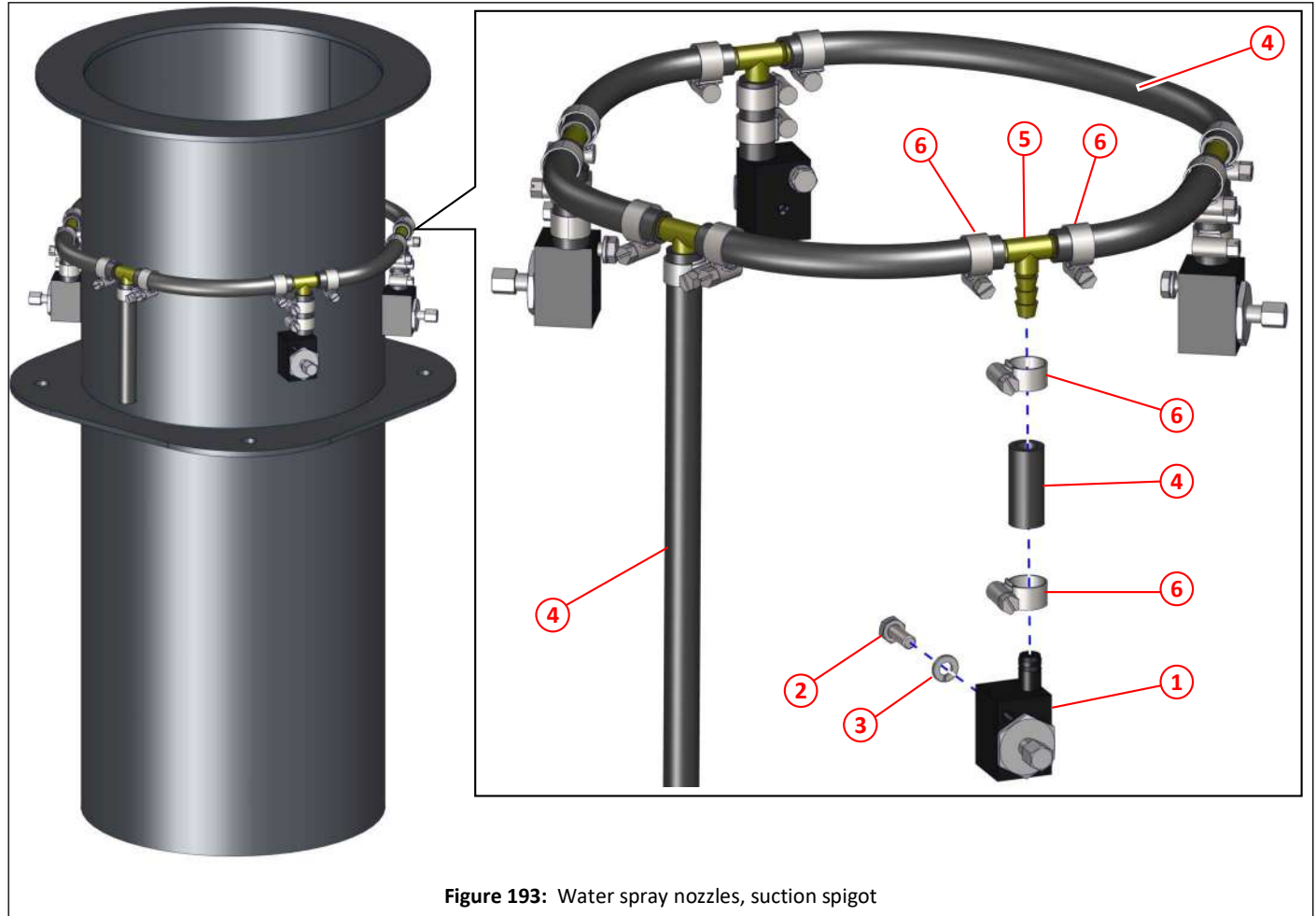

Figure 193: Water spray nozzles, suction spigot

Item	Part No	Qty	Description
①	013360 *	4	Spray jet, square block
②	011067 *	4	Set screw M6 x 20
③	011091 *	4	Spring washer M6
④	010950 *	As req	Hose $\frac{3}{8}$ "
⑤	003000 *	5	Tee, brass, equal. $\frac{3}{8}$ "
⑥	010516	19	Hose clamp, worm drive, No. M00 (ø11mm-ø16mm)

\*. Quantities shown are per suction spigot.



Front spray bar, low pressure

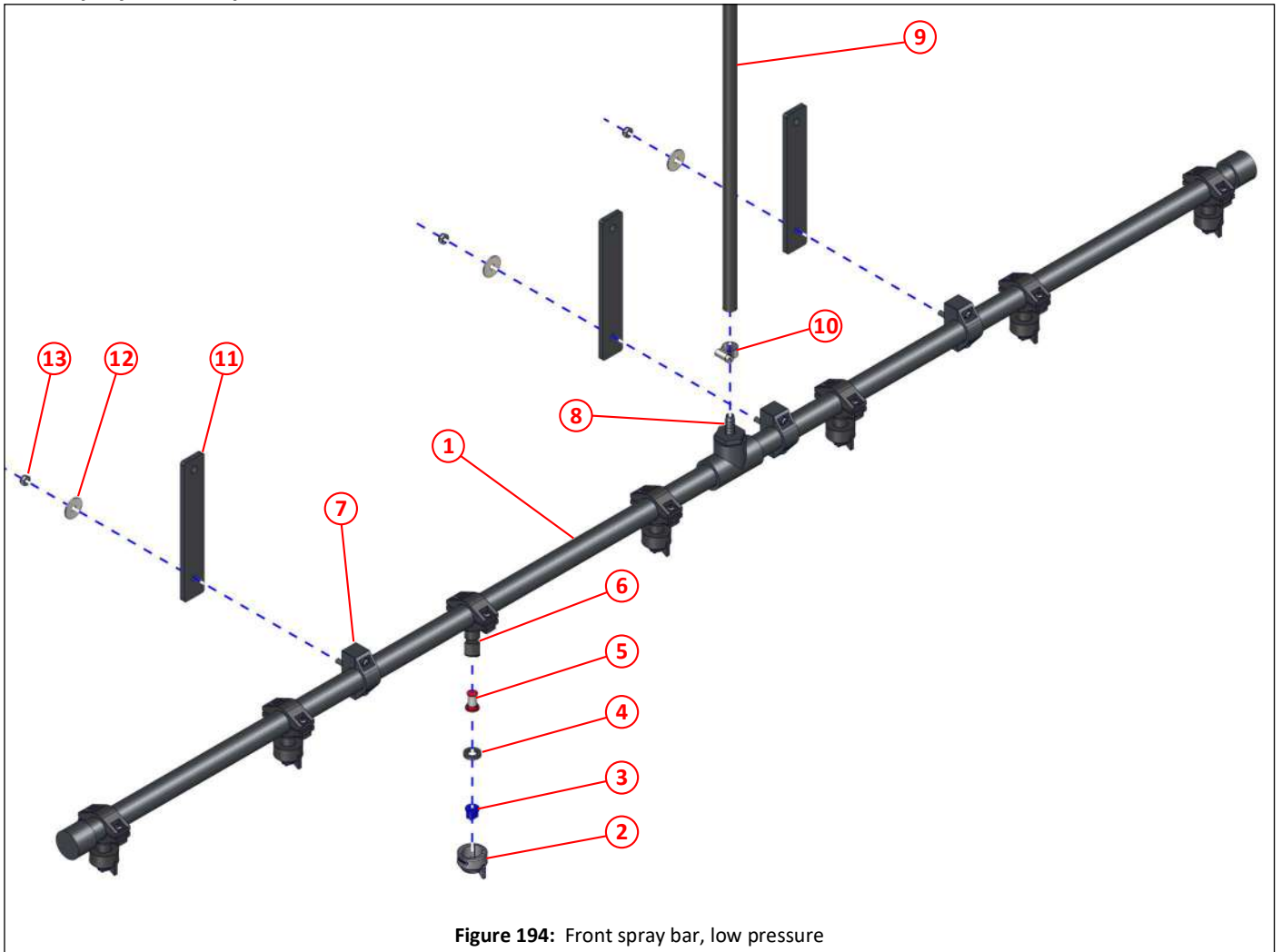

Figure 194: Front spray bar, low pressure

Item	Part No	Qty	Description	
①	030323	1	Spray bar, low pressure, complete, includes items ② to ⑧	
②	030635	7	Cone nozzle cap, per nozzle	
③	030632	7	Jet	
④	030636	7	Rubber washer	
⑤	030633	7	Filter, 100 mesh	
⑥	030634	7	Nozzle holder	
⑦	031338	7	Clamp	
⑧	031339	1	Adapter, hose tail	
⑨	010950	As req	Hose $\frac{3}{8}$ " , from water valves	218
⑩	010516	1	Hose clamp, worm drive, No. M00 ( $\phi$ 11mm- $\phi$ 16mm)	
⑪	036655 *	3	Bracket, low pressure spray bar mounting	
⑫	011099	3	Repair washer $\phi$ $\frac{1}{4}$ " x $\phi$ 1"	
⑬	011071	3	Nyloc nut M6	

\*. These brackets are chassis dependant, contact Scarab Parts Department for the correct item for your particular chassis. Brackets for a DAF 75 shown.

Water nozzle, overhead boom suction tube

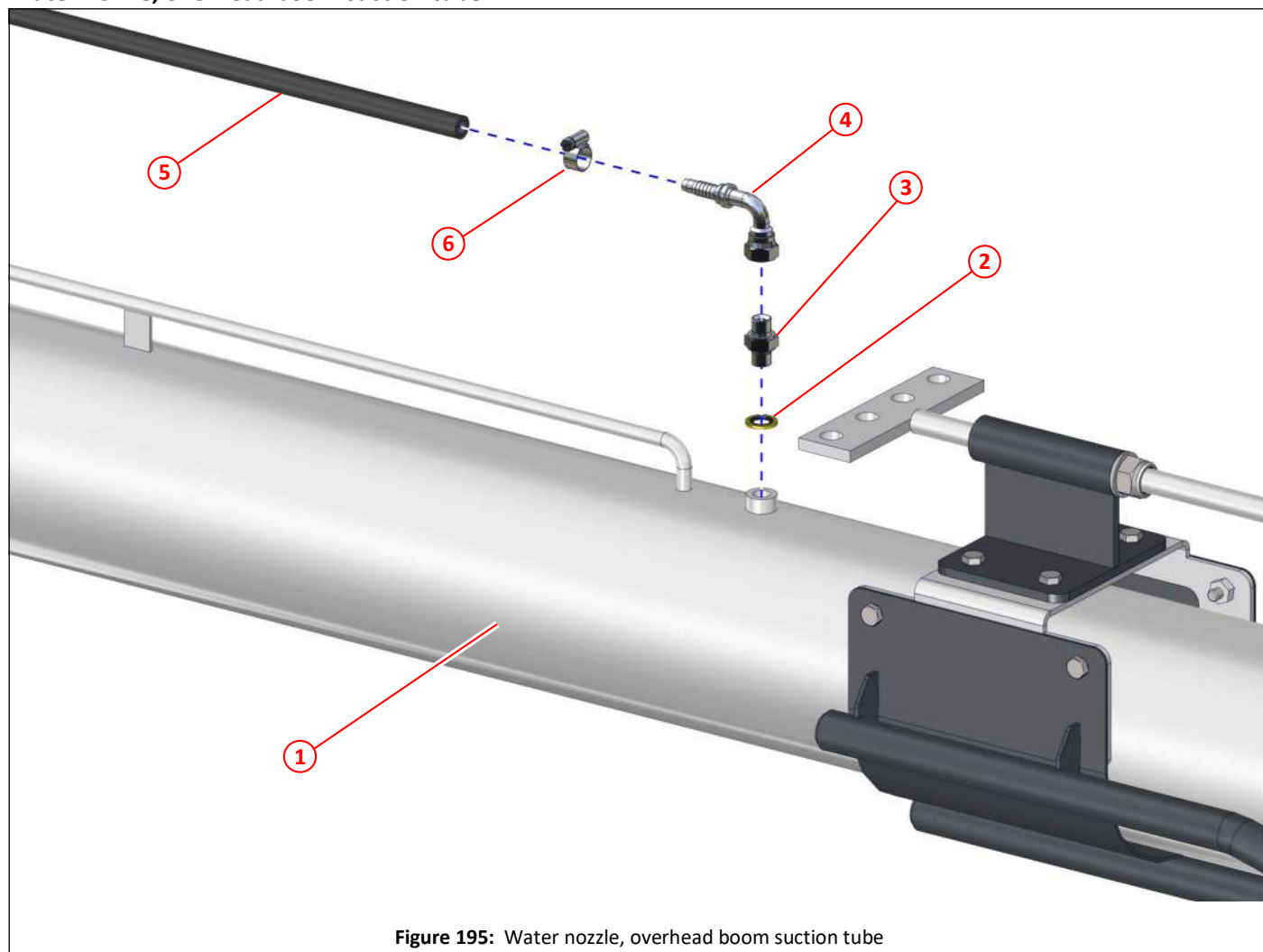

Figure 195: Water nozzle, overhead boom suction tube

Item	Part No	Qty	Description	
①	044120	1	Pipe, suction, overhead boom	123
②	011152	1	Dowty seal $\frac{1}{4}$ " BSP	
③	011158	1	Adapter $\frac{1}{4}$ " BSP	
④	002237	1	Elbow $\frac{1}{4}$ " BSPF x $\frac{3}{8}$ " hose tail, 90°	
⑤	010950	As req	Hose $\varnothing$ 9.5 ID, black braided PVC	
⑥	010516	2	Hose clamp, worm drive, No. M00 ( $\varnothing$ 11mm- $\varnothing$ 16mm)	

Water strainer, high pressure

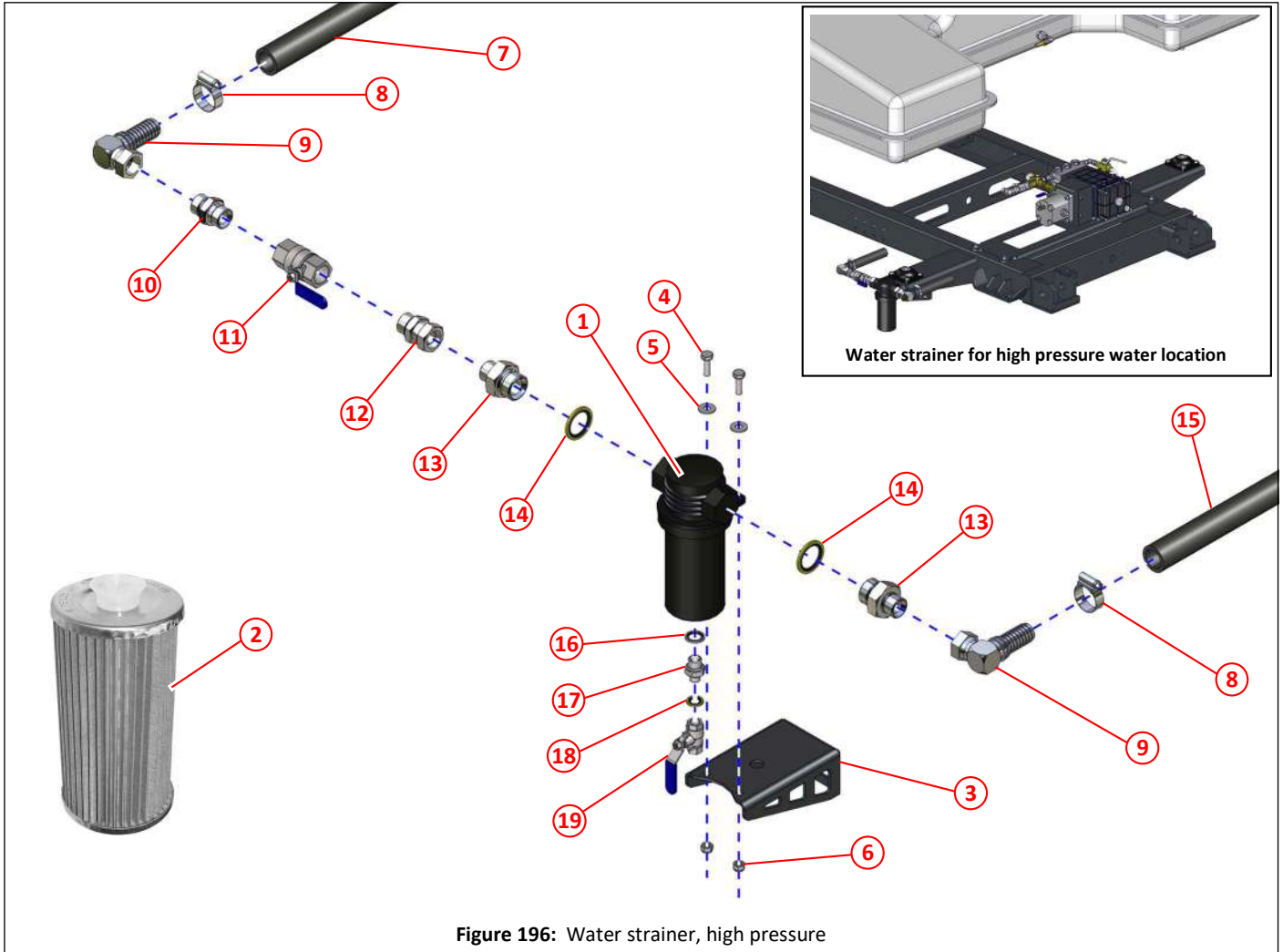

Figure 196: Water strainer, high pressure

Item	Part No	Qty	Description
①	023862	1	Water strainer, complete with filter element
②	023863	1	Filter element
③	043086	1	Bracket, water strainer
④	011011	2	Set screw M8 x 25
⑤	011092	2	Plain washer M8
⑥	011073	2	Nyloc nut M8
⑦	010959	As req	Hose 1", from water tank
⑧	010518	2	Hose clamp, worm drive, No. 1X (ø30-ø40)
⑨	011210	2	Elbow 3/4" BSPF x 1" hose tail
⑩	011161	1	Adapter 3/4" BSP
⑪	013757	1	Valve, ball, 3/4" BSP
⑫	012228	1	Adapter M/F 3/4" BSP
⑬	011193	2	Adapter 1" BSP x 3/4" BSP
⑭	011156	2	Dowty seal 1" BSP
⑮	010959	As req	Hose 1", to high pressure water pump
⑯	011153	1	Dowty seal 3/8" BSP
⑰	011743	1	Adapter, M/M, 3/8" BSP x 1/4" BSP
⑱	011152	1	Dowty seal 1/4" BSP
⑲	011743	1	Valve, ball, 1/4" BSP

Water pump, high pressure 30 LPM, mounting, motor and coupling

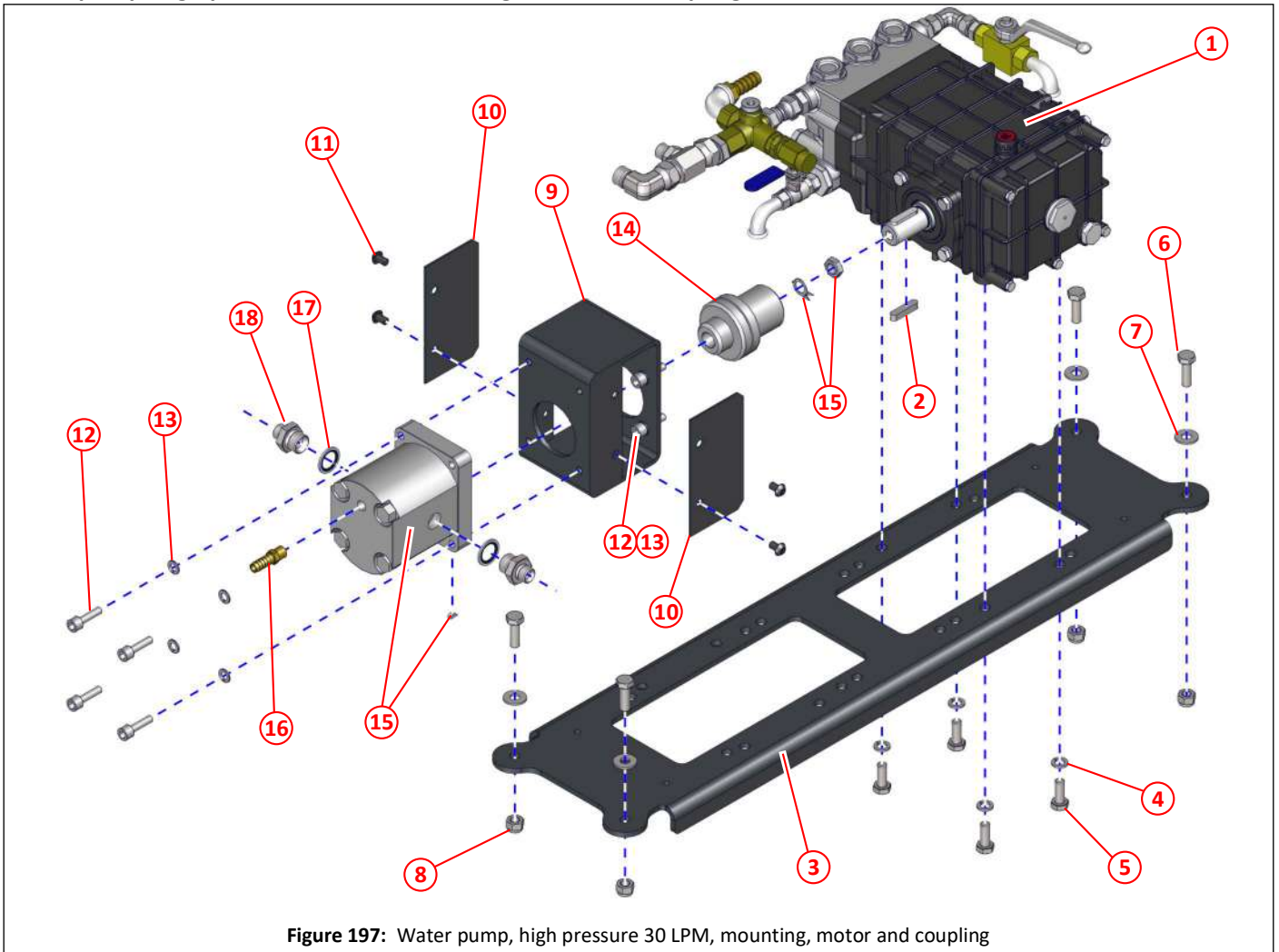

Figure 197: Water pump, high pressure 30 LPM, mounting, motor and coupling

Item	Part No	Qty	Description	
①	039940	1	Water pump, 30 LPM, UDOR	233,234,235
②	011515	1	Key	
③	034374	1	Bracket, high pressure water pump	
④	011095	4	Sprint washer M10	
⑤	011031	4	Set screw M10 x 25	
⑥	011032	4	Set screw M10 x 30	
⑦	011094	4	Plain washer M10	
⑧	011075	4	Nyloc nut M10	
⑨	036654	1	Drive box kit 30lpm pump, includes items ⑩, ⑪, ⑫, ⑬ and ⑭	
⑩		2	Drive box cover	
⑪	000405	4	Socket button head screw, M8 x 12, black	
⑫	000017	8	Socket cap head screw, M8 x 30	
⑬	011093	8	Spring washer M8	
⑭		1	Drive coupling	
⑮	025373	1	Motor, hydraulic, 19cc	279
⑯	003010	1	Adapter, 1/4" BSPT x 3/8" hose tail	
⑰	011154	2	Dowty seal 1/2" BSP	
⑱	011167	2	Adapter, 1/2" BSP x 3/8" BSP	
NI	001149	2	Hose 3/8" BSP x 3550, with straight/90° ends, feed and return for hydraulic motor	

Water pump, high pressure 30 LPM, feed, output and return fittings

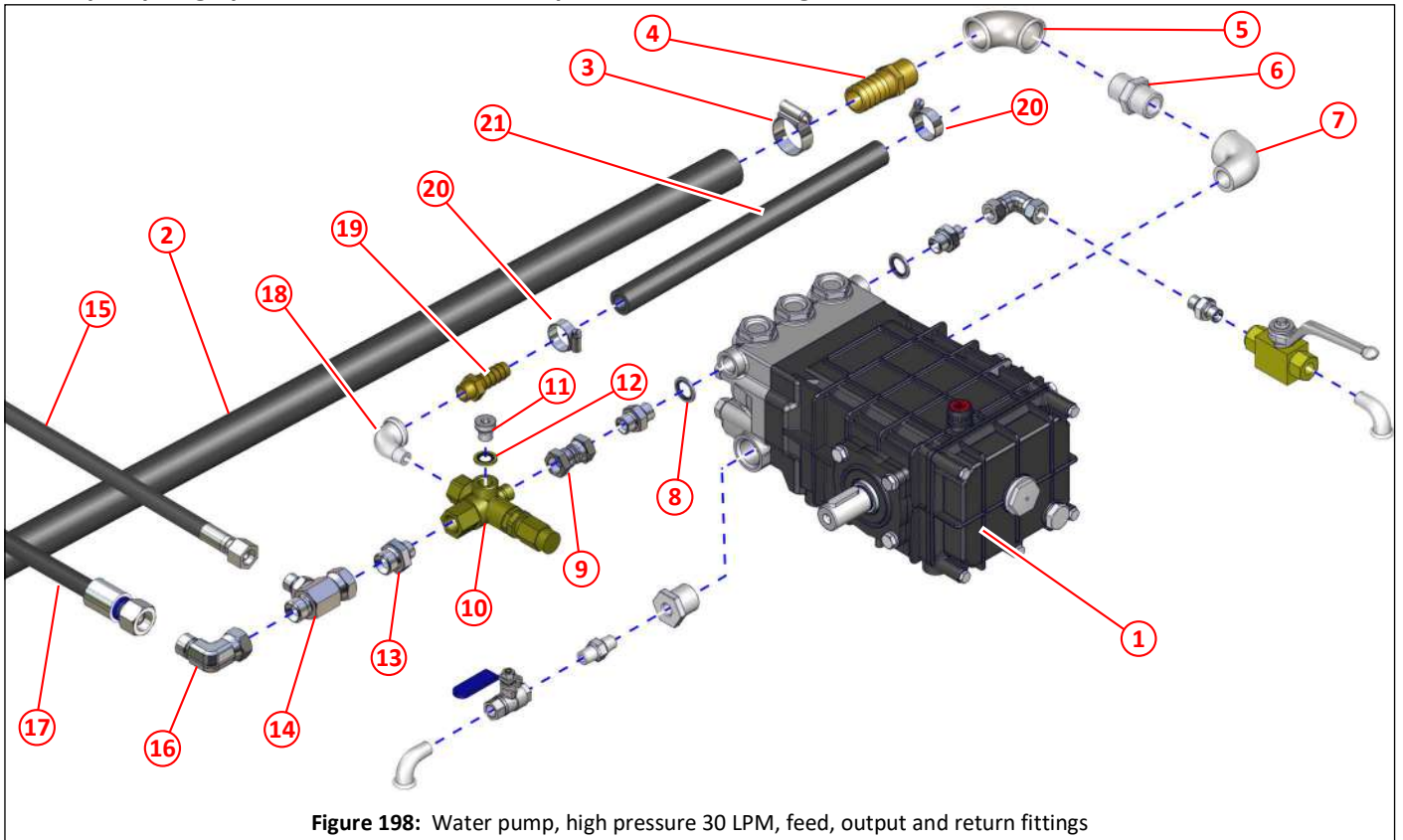

Figure 198: Water pump, high pressure 30 LPM, feed, output and return fittings

Item	Part No	Qty	Description	
①	039940	1	Water pump, 30 LPM, UDOR	232,234,235
②	010959	As req	Hose 1", from water strainer	
③	010518	1	Hose clamp, worm drive, No. 1X (ø30-ø40)	
④	010931	1	Adapter, 3/4" BSP x 1" hose tail	
⑤	010918	1	Elbow, F/F, 3/4" BSP	
⑥	010916	1	Adapter, M/M, 3/4" BSP	
⑦	010917	1	Elbow M/F 3/4" BSP	
⑧	011153	1	Dowty seal 3/8" BSP	
⑨	011214	1	Adapter, 3/8" BSP nut/nut	
⑩	010599	1	Valve, unloader, dual	
⑪	011152	1	Dowty seal 1/4" BSP	
⑫	002016	1	Plug, hex socket head 1/4" BSP	
⑬	011167	1	Adapter, 1/2" BSP x 3/8" BSP	
⑭	002110	1	Tee, 1/2" BSP male x 1/2" BSP female x 3/8" BSP male, reducer on branch	
⑮	011307	1	Hose 3/8" BSP x 1300, straight ends	
⑯	011173	1	Elbow, swivel, M/F, 1/2" BSP	
⑰	001068	1	Hose, 1/2" BSP straight ends, 4000mm, to front spray bar shut off valve	
⑱	010913	1	Elbow, M/F, 3/8" BSP	
⑲	010930	1	Adapter, 3/8" BSP x 5/8", hose tail	
⑳	010517	2	Hose clamp, worm drive, No. 0X (ø18-ø25)	
㉑	011000	As req	Hose, 5/8", return from high pressure pump to water tank	



Water pump, high pressure 30 LPM, drainage fittings

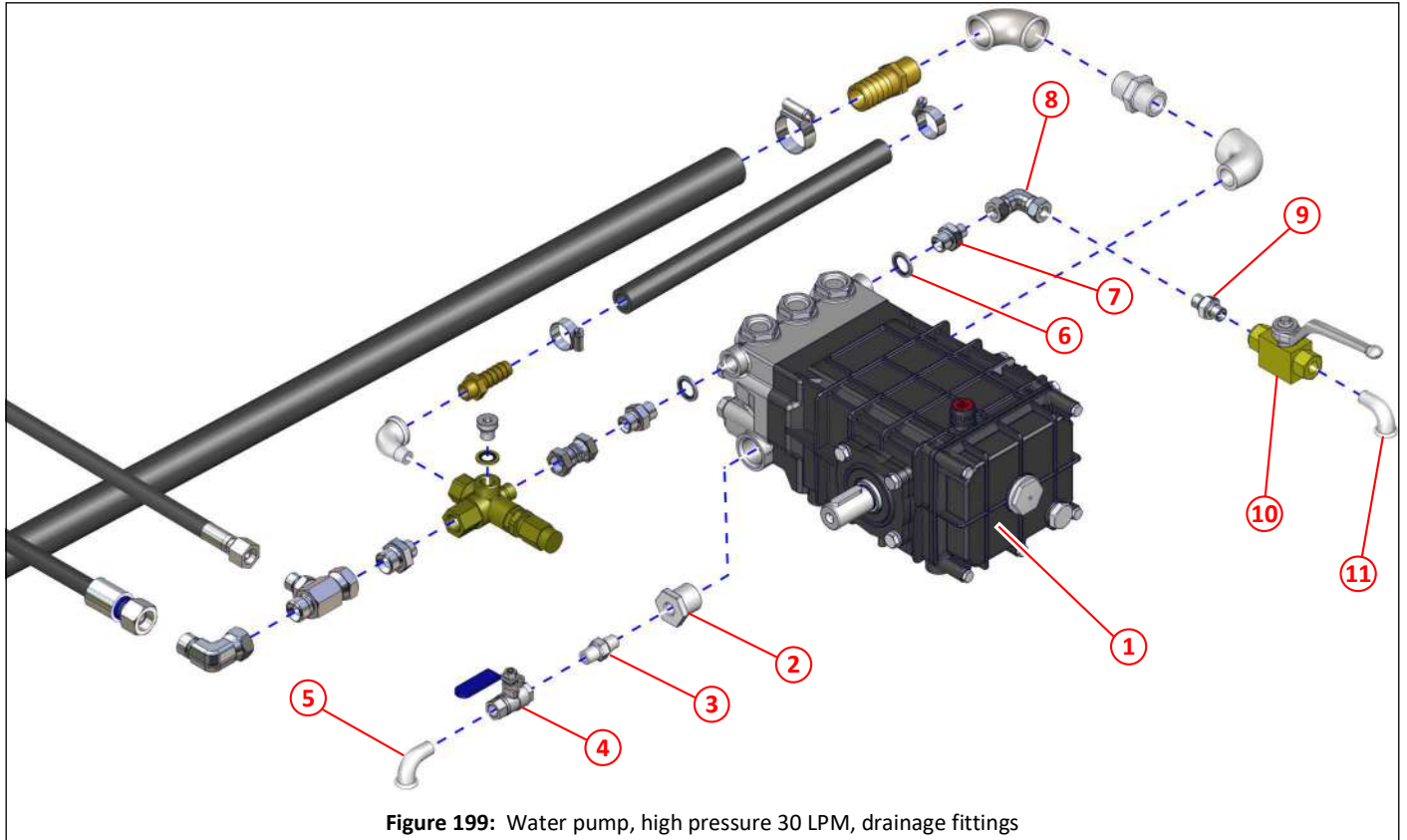

Figure 199: Water pump, high pressure 30 LPM, drainage fittings

Item	Part No	Qty	Description	
①	039940	1	Water pump, 30 LPM, UDOR	232,233,235
②	003006	1	Reducing bush, $\frac{3}{4}$ " BSP x $\frac{1}{4}$ " BSP	
③	010944	1	Adapter, M/M, $\frac{1}{4}$ " BSP	
④	011743	1	Valve, ball, $\frac{1}{4}$ " BSP	
⑤	010910	1	Elbow, M/F, $\frac{1}{4}$ " BSP	
⑥	011153	1	Dowty seal $\frac{3}{8}$ " BSP	
⑦	011199	1	Adapter $\frac{3}{8}$ " BSP x $\frac{1}{4}$ " BSP	
⑧	011169	1	Elbow, swivel, F/F, $\frac{1}{4}$ " BSP	
⑨	011158	1	Adapter, M/M, $\frac{1}{4}$ " BSP	
⑩	011257	1	Valve, ball, $\frac{1}{4}$ " BSP, high pressure	
⑪	010910	1	Elbow, M/F, $\frac{1}{4}$ " BSP	



Water pump, high pressure 30 LPM, seal kits

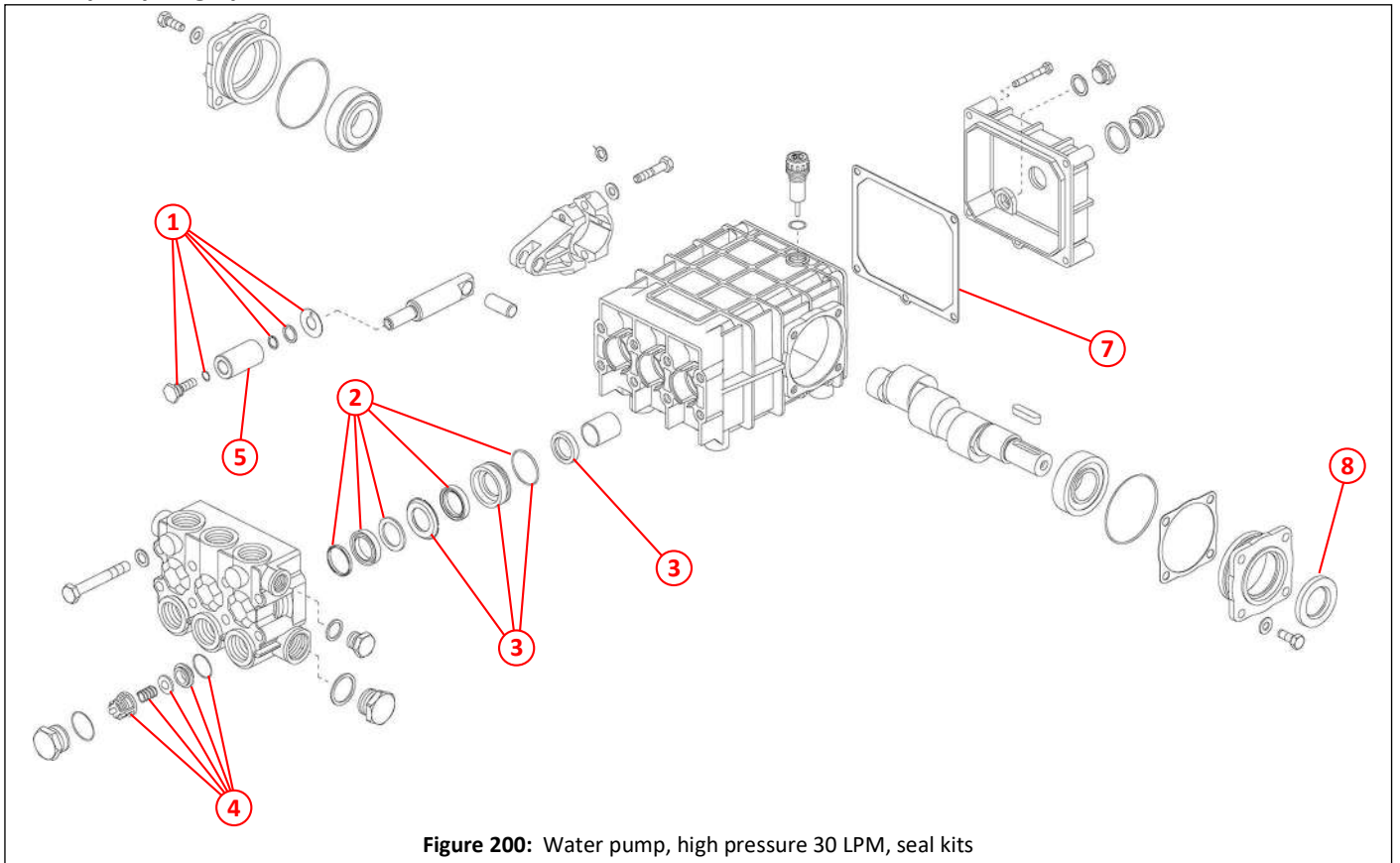

Figure 200: Water pump, high pressure 30 LPM, seal kits

Item	Part No	Qty	Description
①	045356	1	Piston bolt repair (Kit 6), PUCP 606106
②	045357	1	Water seal (Kit 11), PUWS 606111
③	045358	1	Brass insert (Kit 18), PUPB
④	045359	1	Valve (Kit 3), PUVA 606103
⑤	045360	1	Ceramic piston, PUCP 120533
⑥	045361	1	Piston oil seal, PUOS 000743
⑦	045362	1	Crankcase cover gasket, PUGA 060275
⑧	045363	1	Shaft oil seal, PUOS 000738

Front spray bar, combined high pressure/low pressure

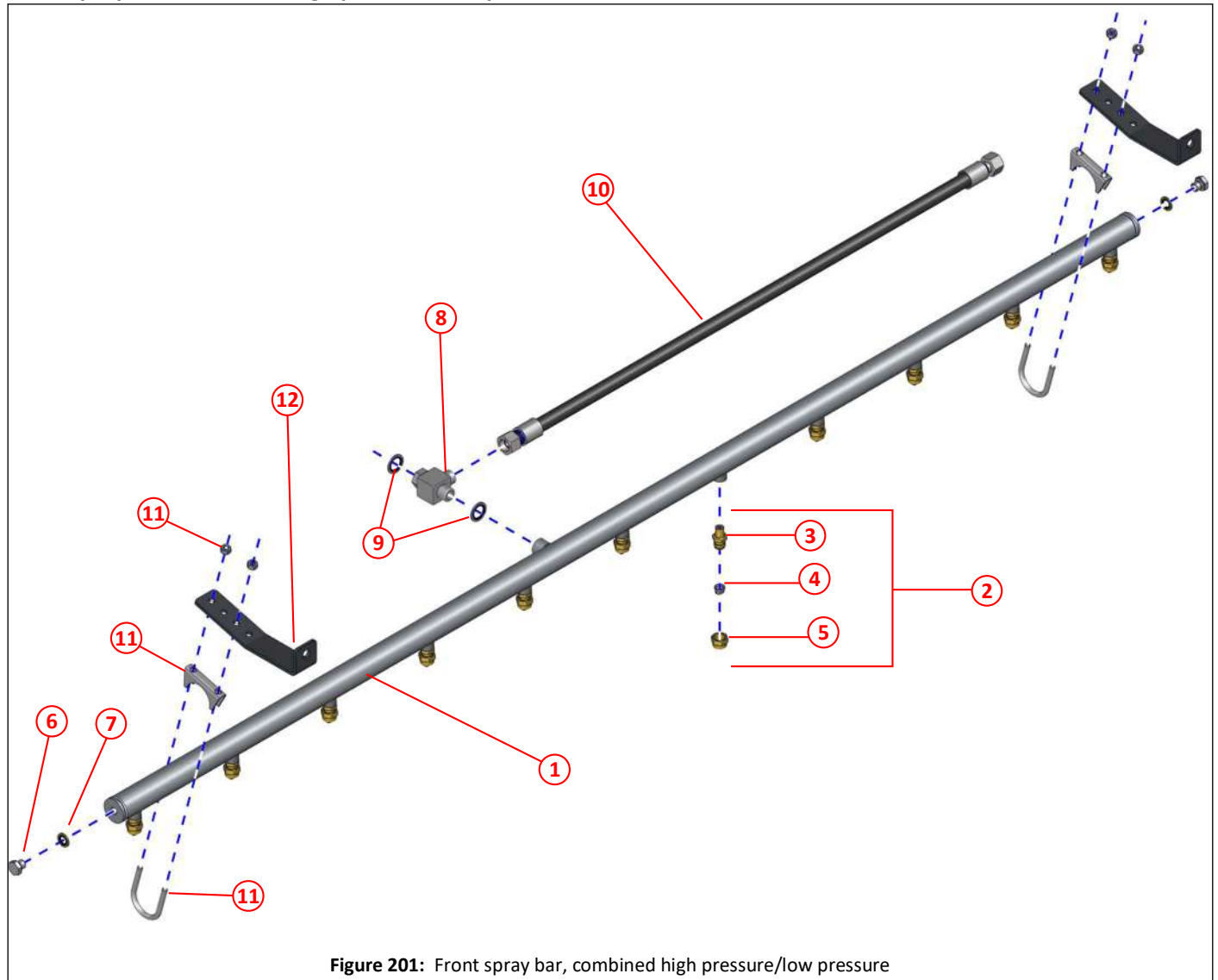

Figure 201: Front spray bar, combined high pressure/low pressure

Item	Part No	Qty	Description
①	020405	1	Spray bar, stainless steel
②	030510	11	Spray jet assembly, contains parts ③, ④ and ⑤
③	010112	1	Nozzle body, per nozzle
④	023377	1	Spray jet, per nozzle
⑤	030951	1	Nozzle cap, per nozzle
⑥	011241	2	Plug 1/4" BSP
⑦	011152	2	Dowty seal 1/4" BSP
⑧	011188	1	Banjo 1/2" BSP
⑨	011154	2	Dowty seal 1/2" BSP
⑩	001068	1	Hose, 1/2" BSP straight ends, 4000mm, from tap
⑪	014983	2	'U' Clamp 1 5/8"
⑫	*	2	Spray bar bracket

\*. Spray bar brackets are dependant on the chassis. Please contact Scarab Parts Department.

Shut off valve and low pressure non return valve, combined front spray bar

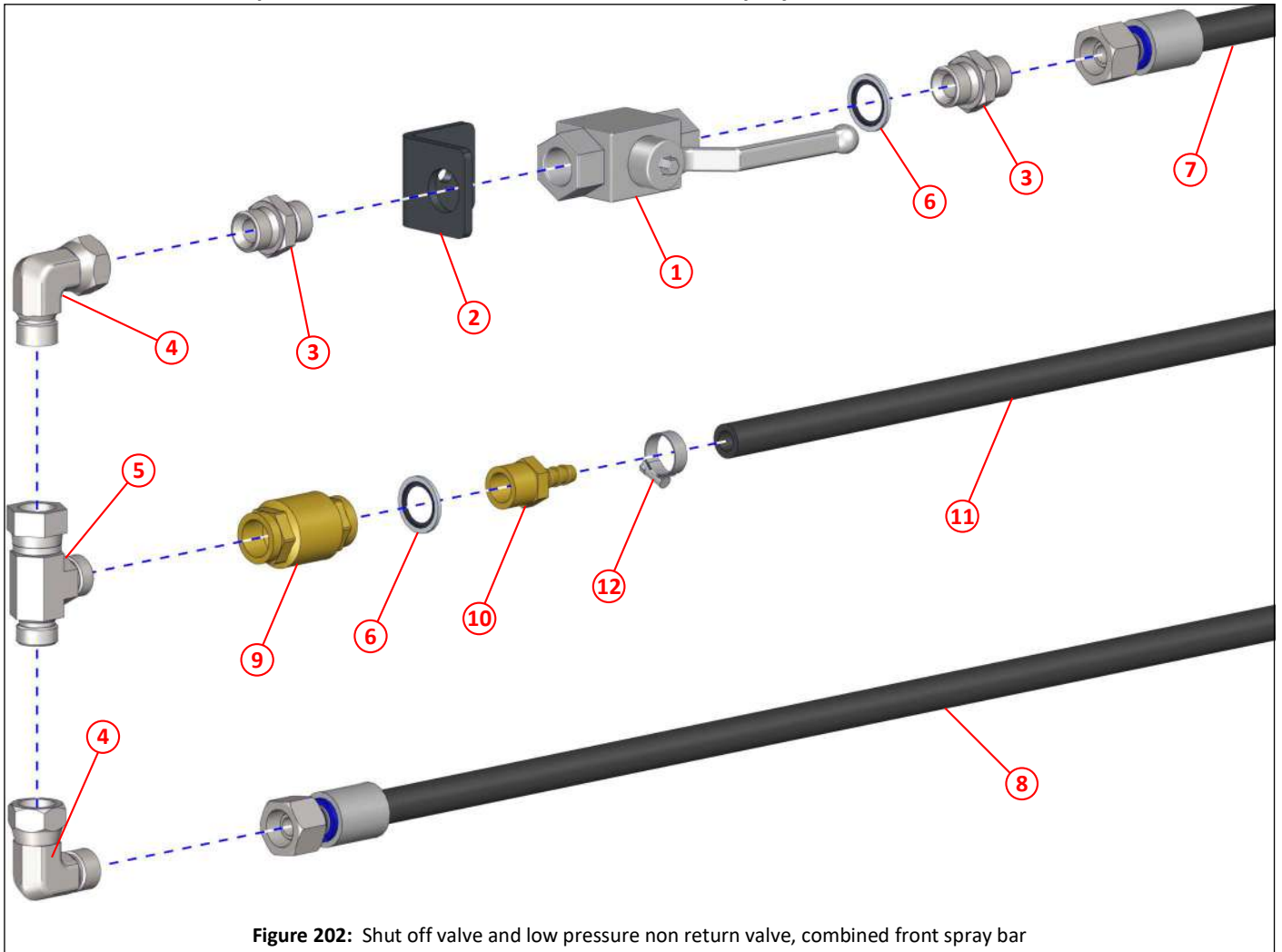

Figure 202: Shut off valve and low pressure non return valve, combined front spray bar

Item	Part No	Qty	Description	
①	023176	1	Valve, ball, 1/2" BSP, (high pressure water shut off)	
②	025007	1	Bracket, spray bar valve	
③	011160	2	Adapter, M/M, 1/2" BSP M/M	
④	011173	2	Elbow, swivel, M/F, 1/2" BSP	
⑤	011182	1	Tee, nut on run, 1/2" BSP	
⑥	011154	2	Dowty seal 1/2" BSP	
⑦	001068	1	Hose, 1/2" BSP straight ends, 4000mm, from high pressure water pump	
⑧	001068	1	Hose, 1/2" BSP straight ends, 4000mm, to high pressure front spray bar	
⑨	003033	1	Valve, non return, 1/2" BSP	
⑩	003034	1	Adapter, male 1/2" BSPT x 3/8" hose tail	
⑪	010950	As req	Hose 3/8", from water valves	218
⑫	010516	1	Hose clamp, worm drive, No. M00 (ø11mm-ø16mm)	

Hose reel and mounting

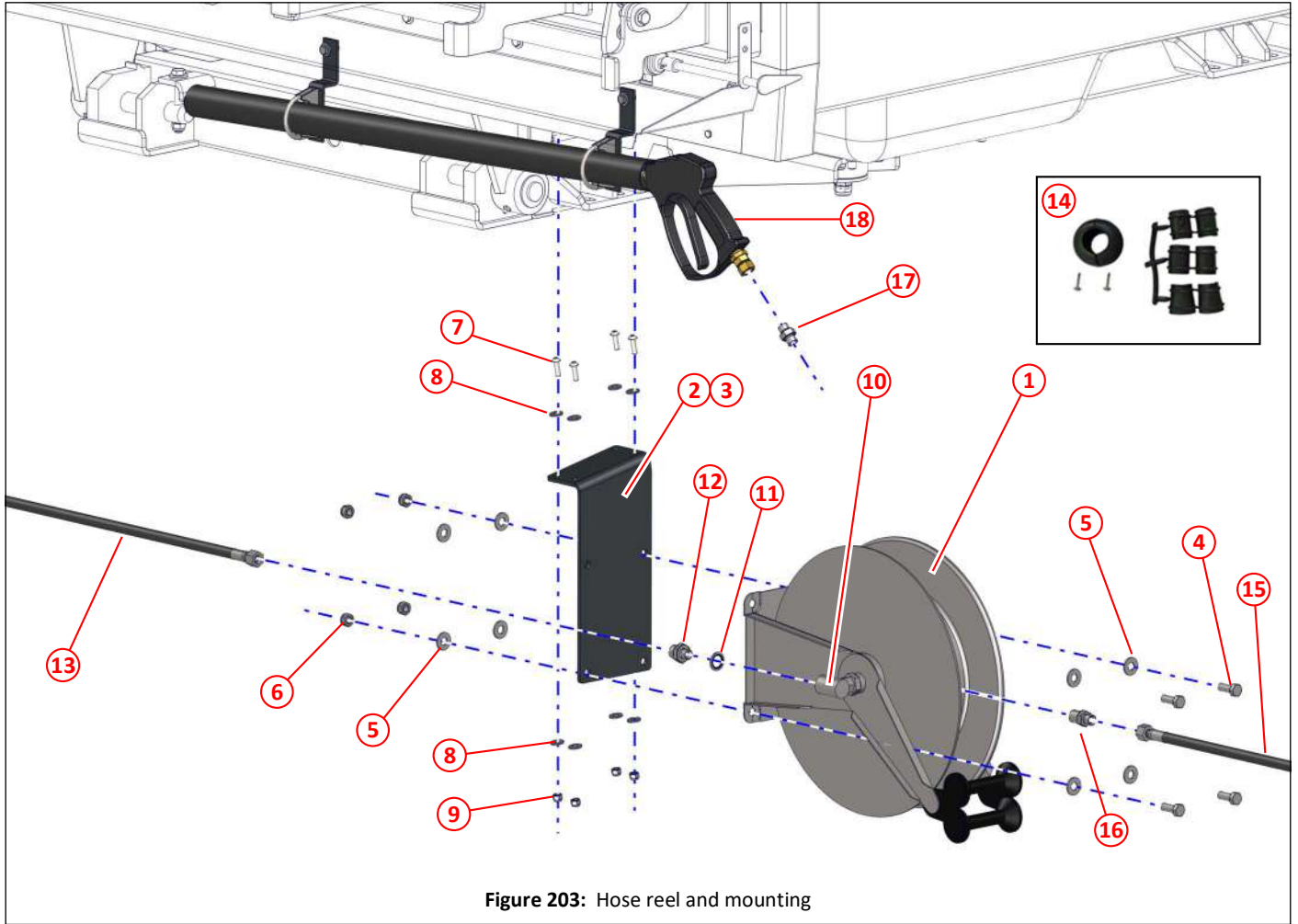

Figure 203: Hose reel and mounting

Item	Part No	Qty	Description
①	020451	1	Hose reel, retracting, without hose
②	034390	1	Mounting bracket, for right hand side
③	039380	1	Mounting bracket, for left hand side
④	011052	4	Set screw M12 x 30
⑤	011096	8	Plain washer M12
⑥	011077	4	Nyloc nut M12
⑦	000281	4	Socket button head set screw M8 x 25, stainless steel
⑧	000264	8	Plain washer, M8, stainless steel
⑨	000263	4	Nyloc nut M8, stainless steel
⑩	026217	1	Elbow, swivel, repair kit
⑪	011154	1	Dowty seal 1/2" BSP
⑫	011167	1	Adapter, M/M, 1/2" BSP x 3/8" BSP
⑬	011307	1	Hose 3/8" BSP x 1300, from high pressure water pump
⑭	026217	1	Clamp, hose retract stop
⑮	010601	13m	Hose, rubber, reinforced
⑯	002204	1	Adapter, M/M, 3/8" BSP x 1/2" NPT, (connector for hose to hose reel)
⑰	011159	1	Adapter, M/M, 3/8" BSP
⑱	010748	1	Hand lance

Hand lance and mounting

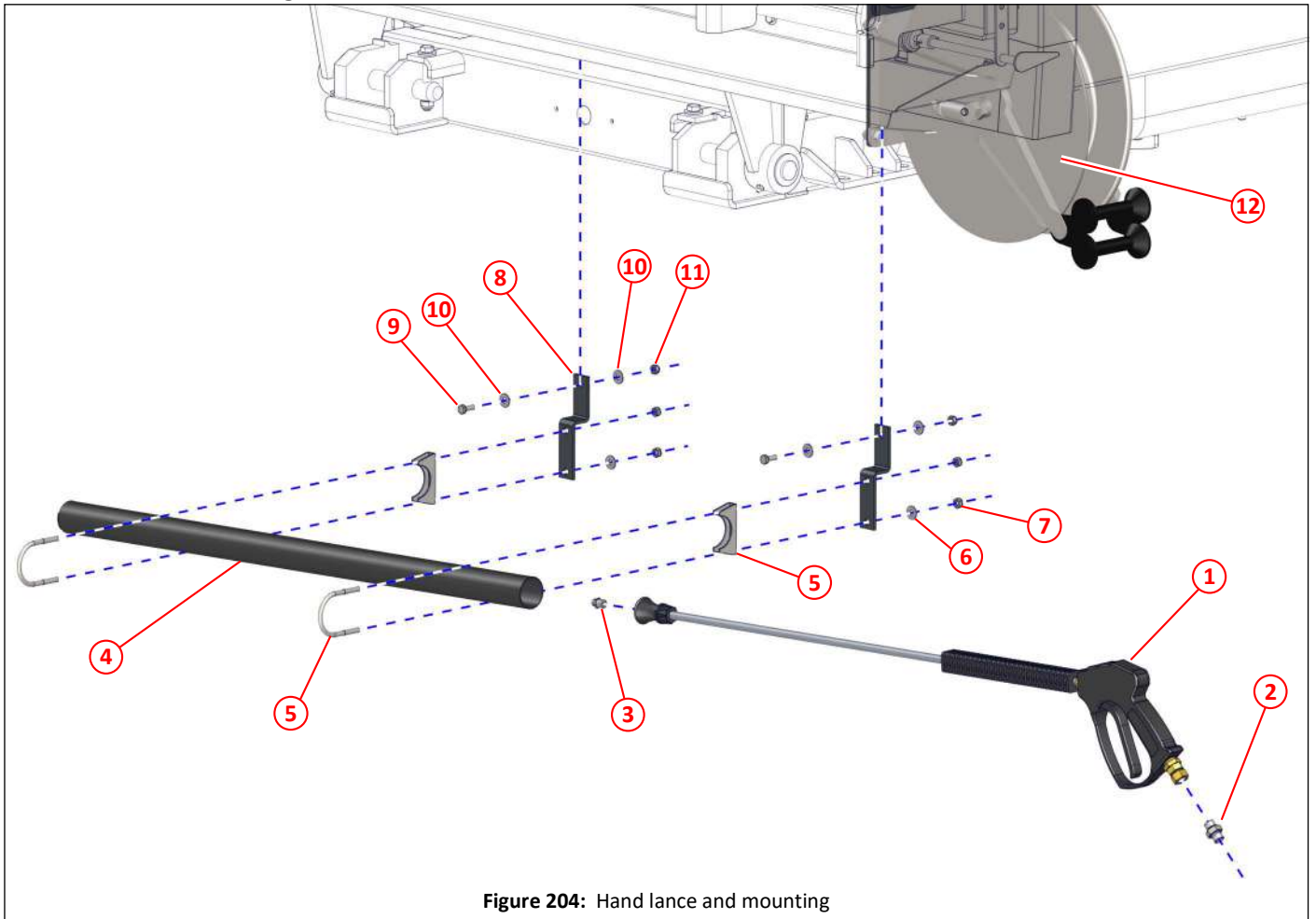

Figure 204: Hand lance and mounting

Item	Part No	Qty	Description	
①	010748	1	Hand lance	
②	011159	1	Adapter, M/M, 3/8" BSP	
③	020758	1	Nozzle 1520	
④	025473	1	Tube, hand lance stowage	
⑤	012901	2	'U'-clamp 2"	
⑥	011092	2	Plain washer M8	
⑦	011073	4	Nyloc nut M8	
⑧	032265	2	Bracket, hand lance stowage tube	
⑨	011010	2	Set screw M8 x 20	
⑩	011092	4	Plain washer M8	
⑪	011073	2	Nyloc nut M8	
⑫	020451	1	Hose reel, retracting, without hose	238

Spray bar, high pressure, front of suction nozzle, mounting

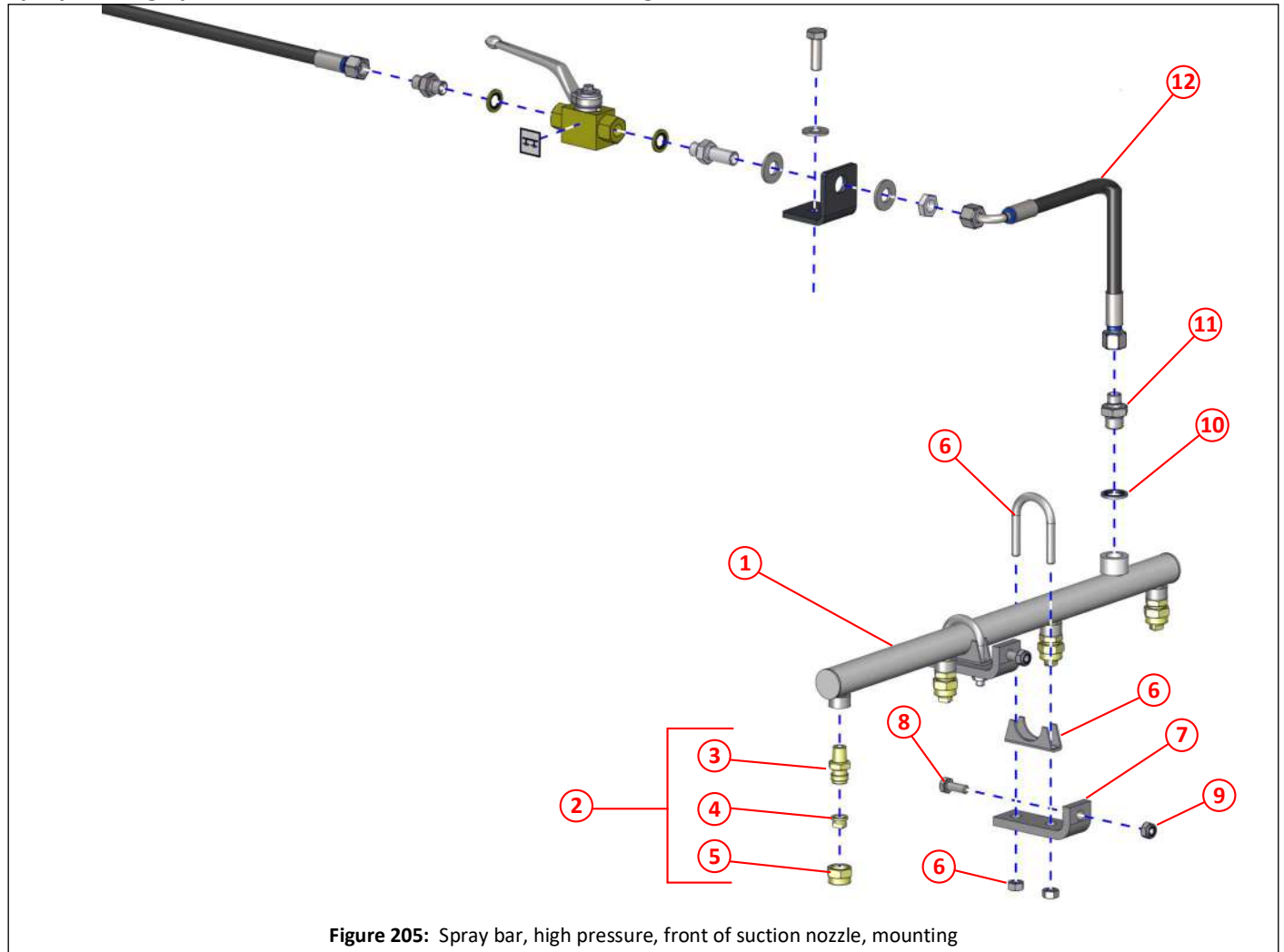

Figure 205: Spray bar, high pressure, front of suction nozzle, mounting

Item	Part No	Qty	Description	
①	020589	1	Spray bar	241
②	030506	4	Complete spray jet assembly, contains items ③, ④ and ⑤	
③	010112	4	Nozzle boy	
④	012316	4	Spray jet	
⑤	030951	4	Nozzle cap	
⑥	020774	2	Pipe 'U'-clamp $\varnothing 32$ ( $\varnothing 1\frac{5}{8}$ "	
⑦	020590	2	Bracket, spray bar	
⑧	011010	2	Set screw M8 x 20	
⑨	011073	2	Nyloc nut M8	
⑩	011153	1	Dowty seal $\frac{3}{8}$ " BSP	
⑪	011199	1	Adapter $\frac{3}{8}$ " BSP x $\frac{1}{4}$ " BSP	
⑫	001104	1	Hose $\frac{1}{4}$ " BSP x 460, straight/90° ends	



Spray bar, high pressure, front of suction nozzle, water feed and shut off valve

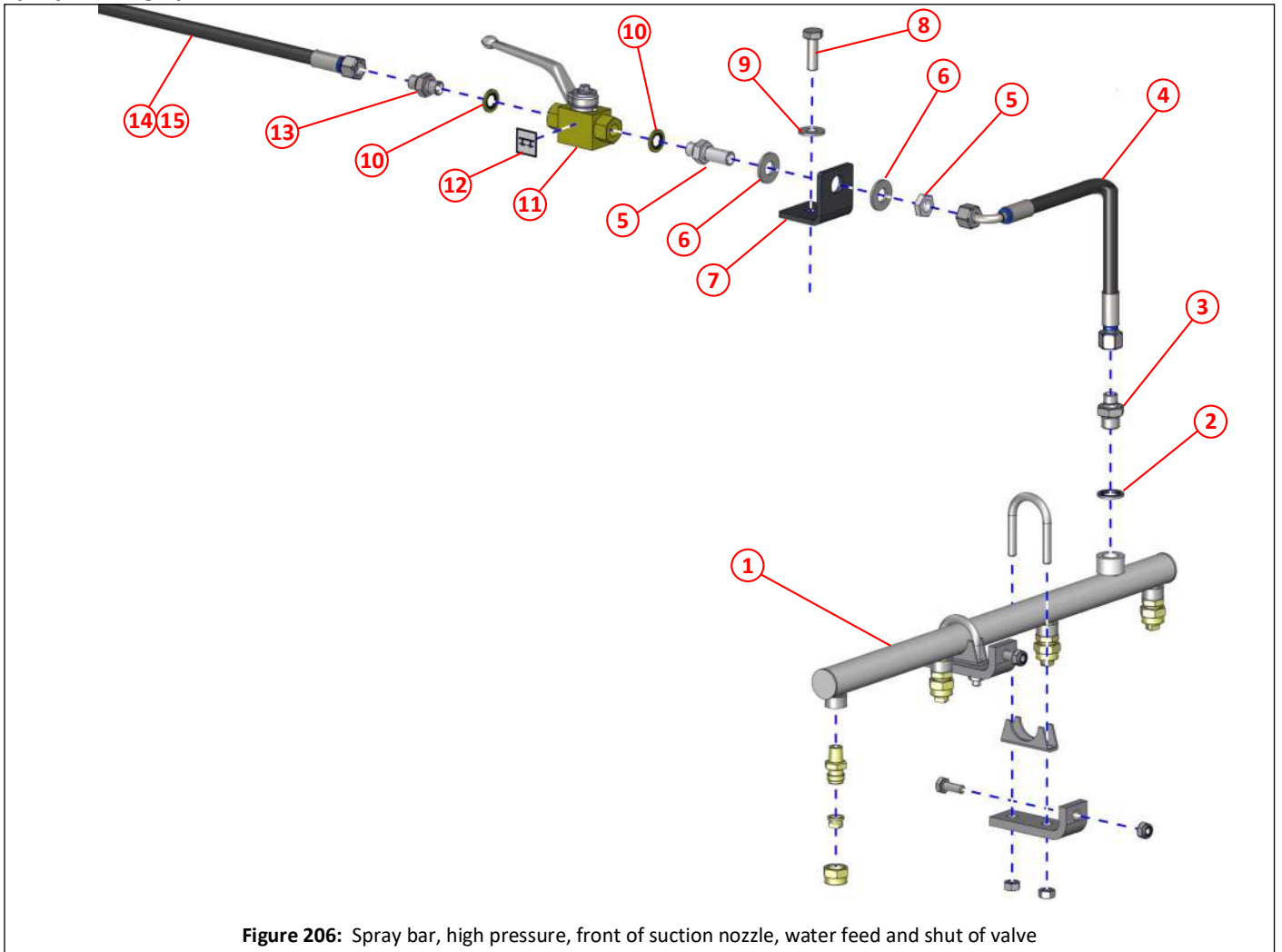

Figure 206: Spray bar, high pressure, front of suction nozzle, water feed and shut of valve

Item	Part No	Qty	Description	
①	020589	1	Spray bar	240
②	011153	1	Dowty seal $\frac{3}{8}$ " BSP	
③	011199	1	Adapter $\frac{3}{8}$ " BSP x $\frac{1}{4}$ " BSP	
④	001104	1	Hose $\frac{1}{4}$ " BSP x 460, straight/90° ends	
⑤	011269	1	Adapter, bulkhead, $\frac{1}{4}$ " BSP	
⑥	011096	2	Plain washer M12	
⑦	012548	1	Angle bracket	
⑧	011030	1	Set screw M10 x 20	
⑨	011095	1	Spring washer M10	
⑩	011152	2	Dowty seal $\frac{1}{4}$ " BSP	
⑪	011257	1	Valve, ball, $\frac{1}{4}$ " BSP, high pressure	
⑫	039547	1	Label - High pressure spray	
⑬	011158	1	Adapter $\frac{1}{4}$ " BSP	
⑭	001264	1	Hose $\frac{1}{4}$ " BSP x 1000, straight ends, for left side	
⑮	010987	1	Hose $\frac{1}{4}$ " BSP x 1660, straight ends, for right side	

Spray bar, high pressure, rear of suction nozzle, mounting

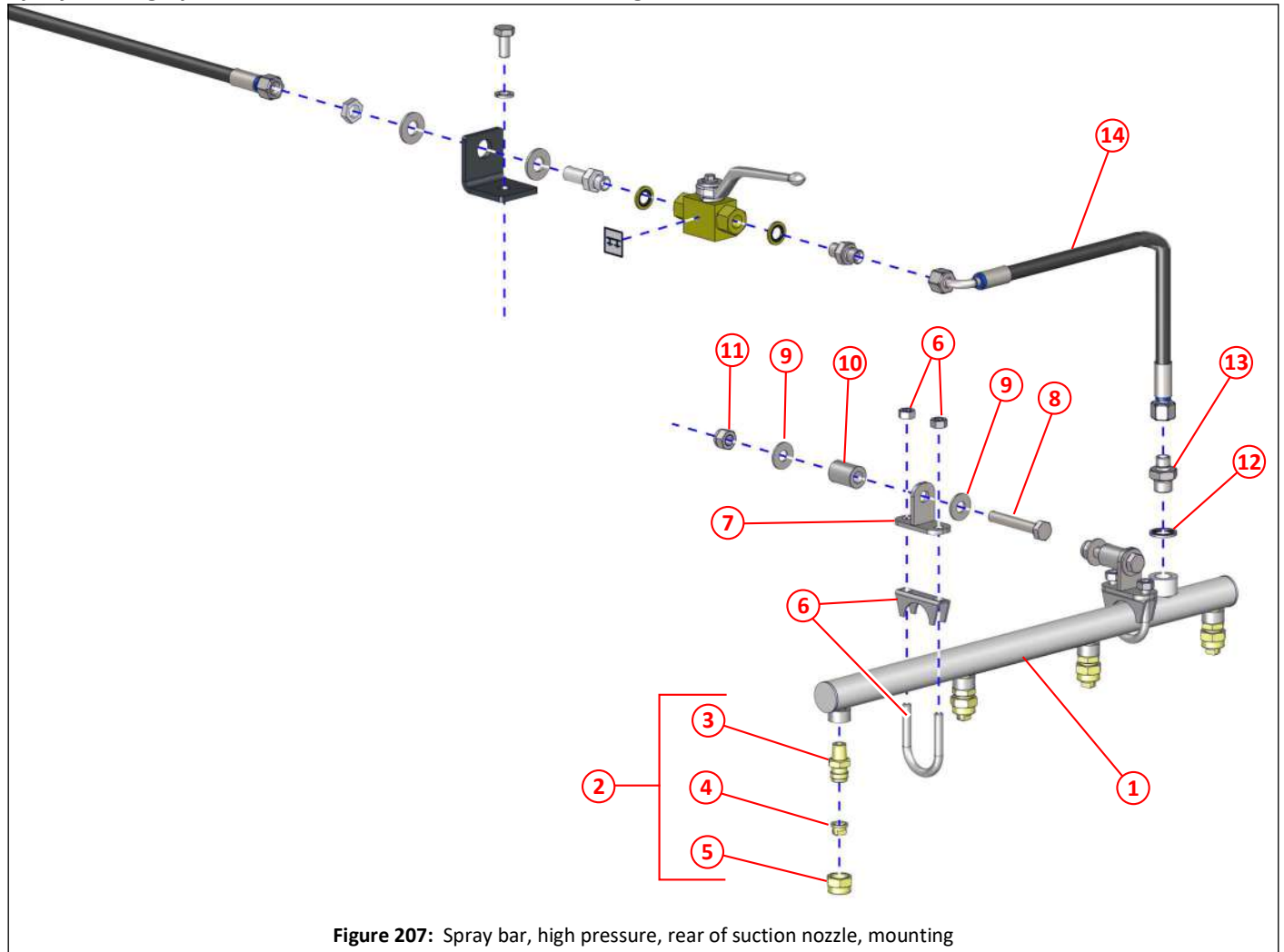

Figure 207: Spray bar, high pressure, rear of suction nozzle, mounting

Item	Part No	Qty	Description	
①	020589	1	Spray bar	243
②	030506	4	Complete spray jet assembly, contains items ③, ④ and ⑤	
③	010112	4	Nozzle boy	
④	012316	4	Spray jet	
⑤	030951	4	Nozzle cap	
⑥	020774	2	Pipe 'U'-clamp $\varnothing 32$ ( $\varnothing 1\frac{5}{8}$ "	
⑦	041466	2	Bracket	
⑧	011036	2	Bolt M10 x 60	
⑨	011094	4	Plain washer M10	
⑩	012981	2	Spacer $\varnothing 11$ x $\varnothing 20$ x 27	
⑪	011075	2	Nyloc nut M10	
⑫	011153	1	Dowty seal $\frac{3}{8}$ " BSP	
⑬	011199	1	Adapter $\frac{3}{8}$ " BSP x $\frac{1}{4}$ " BSP	
⑭	001100	1	Hose $\frac{1}{4}$ " BSP x 1020, straight/90° ends	

Spray bar, high pressure, rear of suction nozzle, water feed and shut off valve

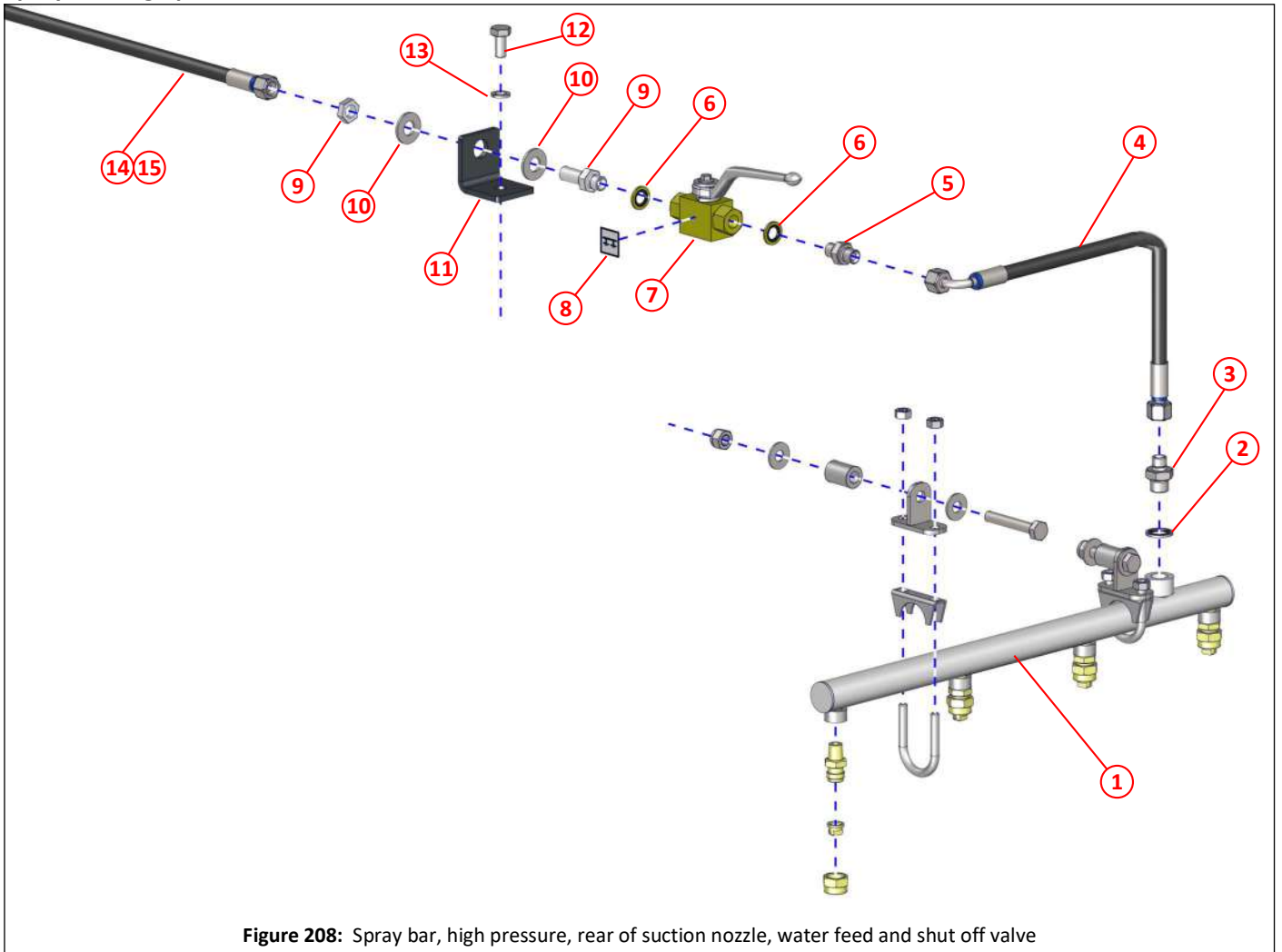

Figure 208: Spray bar, high pressure, rear of suction nozzle, water feed and shut off valve

Item	Part No	Qty	Description	
①	020589	1	Spray bar	242
②	011153	1	Dowty seal $\frac{3}{8}$ " BSP	
③	011199	1	Adapter $\frac{3}{8}$ " BSP x $\frac{1}{4}$ " BSP	
④	001104	1	Hose $\frac{1}{4}$ " BSP x 1020, straight/90° ends	
⑤	011158	1	Adapter $\frac{1}{4}$ " BSP	
⑥	011152	2	Dowty seal $\frac{1}{4}$ " BSP	
⑦	011257	1	Valve, ball, $\frac{1}{4}$ " BSP, high pressure	
⑧	039547	1	Label - High pressure spray	
⑨	011269	1	Adapter, bulkhead, $\frac{1}{4}$ " BSP	
⑩	011096	2	Plain washer M12	
⑪	012548	1	Angle bracket	
⑫	011030	1	Set screw M10 x 20	
⑬	011095	1	Spring washer M10	
⑭	001264	1	Hose $\frac{1}{4}$ " BSP x 1000, straight ends, for left side	
⑮	010987	1	Hose $\frac{1}{4}$ " BSP x 1660, straight ends, for right side	

Spray bar, high pressure, central brush (wide sweep), mounting, water feed and shut off valve

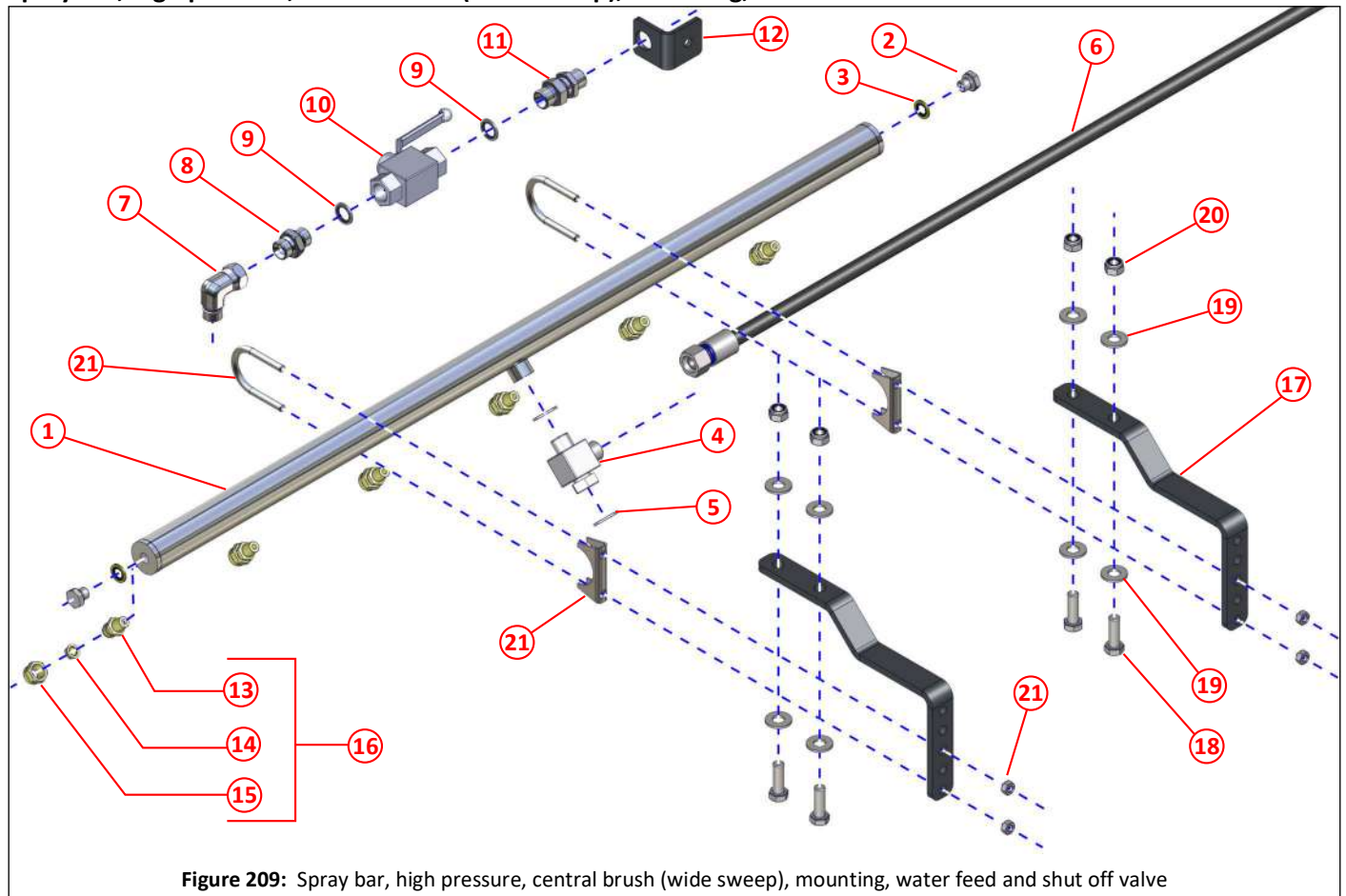

Figure 209: Spray bar, high pressure, central brush (wide sweep), mounting, water feed and shut off valve

Item	Part No	Qty	Description
①	041451	1	Spray bar, central brush (wide sweep) mounted, standard width
②	011241	2	Plug 1/4" BSP
③	011152	2	Dowty seal 1/4" BSP
④	011188	1	Banjo 1/2" BSP
⑤	011154	2	Dowty seal 1/2" BSP
⑥	001242	1	Hose 1/2" BSP x 1750, straight ends, from shut off valve
⑦	011173	1	Elbow, swivel, M/F, 1/2" BSP
⑧	011160	1	Adapter, M/M, 1/2" BSP
⑨	011154	2	Dowty seal 1/2" BSP
⑩	023176	1	Valve, ball, 1/2" BSP, (high pressure water shut off)
⑪	011268	1	Adapter, bulkhead, 1/2" BSP, includes nut
⑫	025007	1	Bracket, spray bar valve
⑬	010112	6	Nozzle body
⑭	012316	6	Spray jet
⑮	030951	6	Nozzle cap
⑯	030506	6	Complete spray jet assembly, contains items ⑬, ⑭ and ⑮
⑰	041452	2	Bracket, spray bar , central brush (wide sweep) mounted
⑱	011053	4	Set screw M12 x 35
⑲	011096	8	Plain washer M12
⑳	011077	4	Nyloc nut M12
㉑	014983	2	'U' Clamp 1 5/8"

Fan wash assist

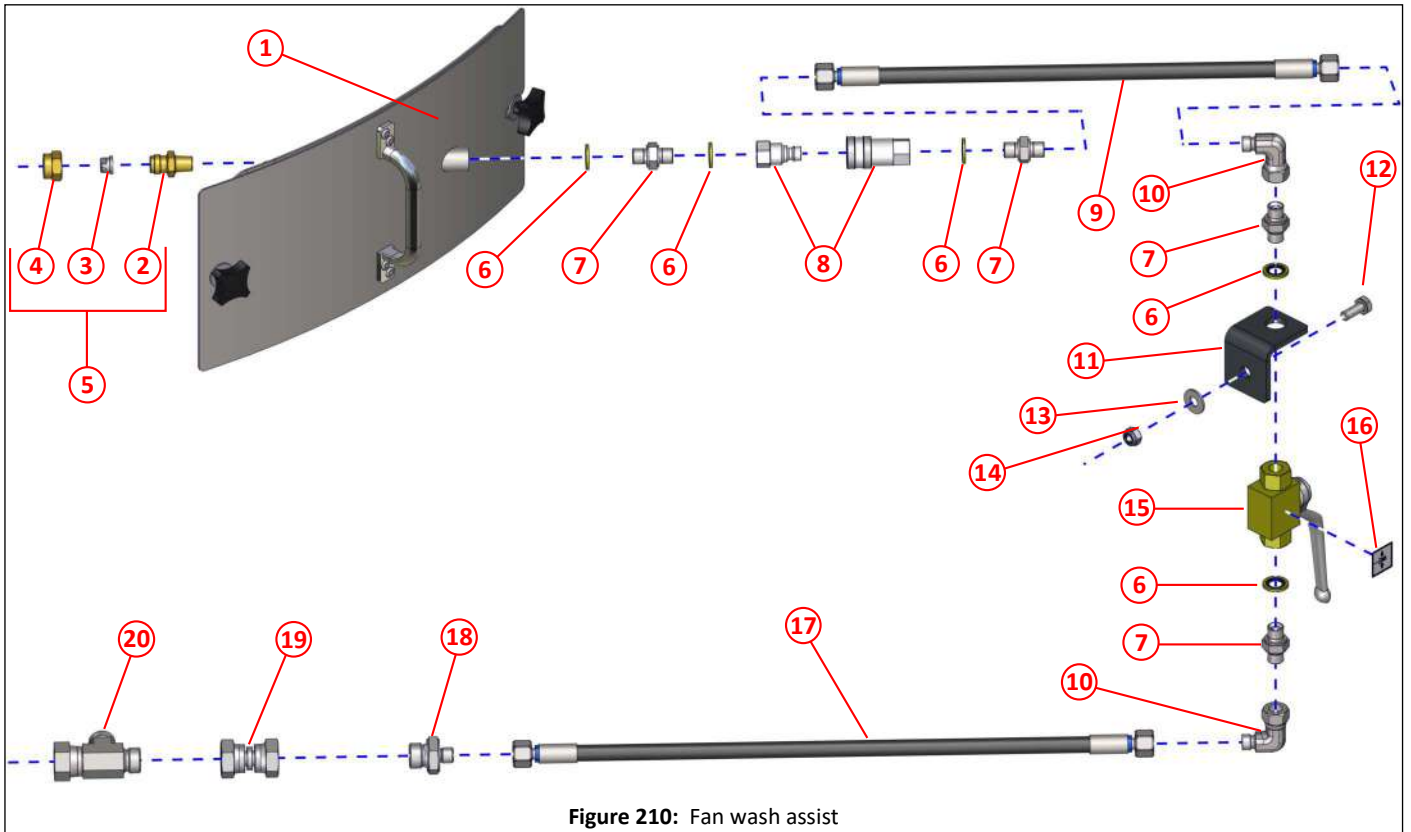

Figure 210: Fan wash assist

Item	Part No	Qty	Description	
①	030731	1	Cover, fan clear, quick release	164
②	010112	1	Nozzle body	
③	012926	1	Spray jet	
④	030951	1	Nozzle cap	
⑤	030507	1	Complete spray jet assembly, contains items ②, ③ and ④	
⑥	011152	5	Dowty seal 1/4" BSP	
⑦	011158	4	Adapter, M/M, 1/4" BSP	
⑧	012985	1	Quick release coupling, 1/4" BSP	
⑨	001002	1	Hose 1/4" BSP x 3700, straight ends	
⑩	011171	2	Elbow, swivel, M/F, 1/4" BSP	
⑪	012548	1	Angle bracket	
⑫	011010	1	Set screw M8 x 20	
⑬	011092	1	Plain washer M8	
⑭	011073	1	Nyloc nut M8	
⑮	011257	1	Valve, ball, 1/4" BSP, high pressure	
⑯	039547	1	Label - High pressure spray	
⑰	001027	1	Hose 1/4" BSP x 1270, straight ends	
⑱	011165	1	Adapter, M/M, 1/2" BSP x 1/4" BSP	
⑲	011178	1	Adapter, 1/2" BSP, nut/nut	
⑳	011182	1	Tee, 1/2" BSP, nut on run	





# Hydraulics

<i>Description</i>	<i>Page</i>
Combined intercooler/radiator/hydraulic oil cooler .....	248
Hydraulic tank and fittings .....	249
Hydraulic tank and fittings .....	250
Hydraulic suction manifold .....	251
Fan pump and gear pumps, general arrangement .....	252
Fan pump and fittings .....	253
Gear pumps and fittings .....	254
Flow control valves and fittings .....	255
Hydraulic high pressure oil filters and fittings .....	256
Suction fan and suction nozzle tilt control circuits, general arrangement .....	257
Suction fan control circuit .....	258
Suction fan control circuit .....	259
Suction nozzle tilt control valve .....	260
Suction fan motor .....	261
Valve blocks, arrangement .....	262
Main valve block, coils, solenoids, check valves and plugs .....	263
Main valve block, fittings .....	264
Main valve block, pipes and hoses .....	265
Options valve block, coils and solenoids .....	266
Options valve block, fittings, pipes and hoses .....	267
Hopper control valve, coils and solenoids .....	268
Hopper control valve, fittings and hoses .....	269
Hand pump, hopper and rear door .....	270
Ram, dual stage, hopper lift .....	271
Ram, rear door open/close/locking .....	272
Ram, side brush lift .....	273
Ram, suction nozzle tilt .....	274
Motor, side brush .....	275
Motor, central brush (wide sweep) .....	276
Motor, suction fan .....	277
Motor, low pressure water pump .....	278
Motor, high pressure water pump .....	279
Hoses .....	280
Pipes .....	281
Steel pipes, brushes, left hand sweep .....	281
Steel pipes, brushes, left hand sweep .....	282
Clamp blocks, steel pipes, brushes, left hand sweep .....	283
Steel pipes, brushes, right hand sweep .....	284
Clamp blocks, steel pipes, brushes, left hand sweep .....	285
Steel pipes, options block .....	286
Clamp blocks, steel pipes, options block .....	287
Steel pipes, suction fan and rear door open/close/lock .....	288
Clamp blocks, steel pipes, suction fan and rear door open/close/lock .....	289

Combined intercooler/radiator/hydraulic oil cooler

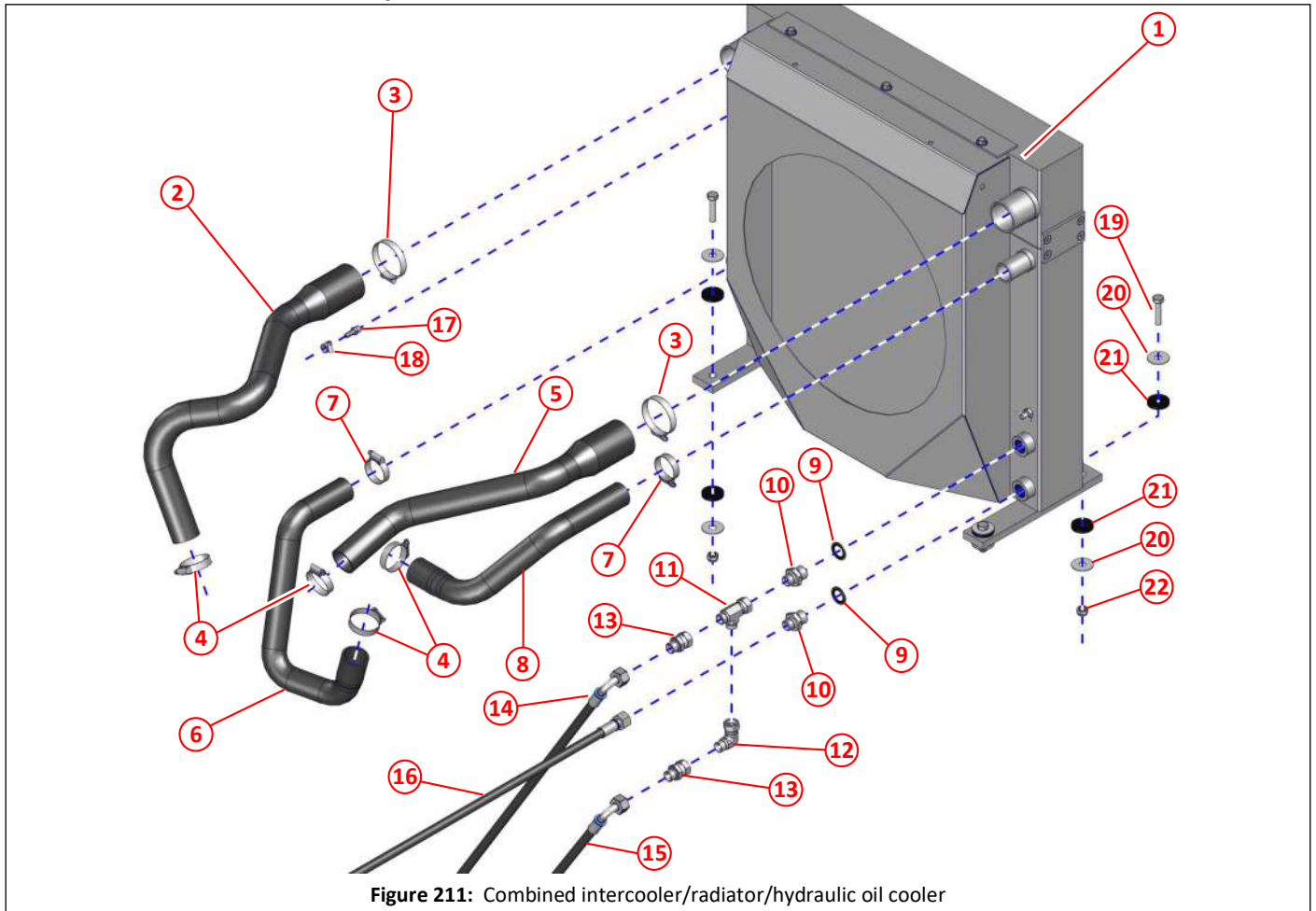

Figure 211: Combined intercooler/radiator/hydraulic oil cooler

Item	Part No	Qty	Description	
①	042800	1	Combined intercooler/radiator/hydraulic oil cooler	348
②	042893	1	Intercooler hose 'A'	
③	010595	2	Hose clamp, worm drive, No 3 (ø55-ø70)	
④	012927	5	Hose clamp, worm drive, No 2 (ø40-ø55)	
⑤	042894	1	Intercooler hose 'B'	
⑥	042896	1	Coolant hose 'B'	
⑦	003007	2	Hose clamp, worm drive, No 2A (ø35-ø50)	
⑧	042895	1	Coolant hose 'A'	
⑨	002082	2	Dowty Seal M26	
⑩	002074	2	Adapter, M/M, M26 x 1/2" BSP	
⑪	011182	1	Tee, 1/2" BSP, nut on run	
⑫	011173	1	Elbow, swivel, M/F, 1/2" BSP	
⑬	011177	2	Adapter, swivel, M/F 1/2" BSP	
⑭	001328	1	Hose, 1/2" BSP x 810, straight and 90° ends, to Port T2 on main valve block	
⑮	001271	1	Hose, 1/2" BSP x 960, straight and 90° ends, to Port T1 on main valve block	
⑯	001308	1	Hose, 1/2" BSP x 2200, straight ends, from tank	
⑰	006044	1	Adapter, 1/4" BSP male x 8mm hose tail	
⑱	010516	1	Hose clamp, worm drive, No M00 (ø11-ø16)	
⑲	000024	4	Set screw M12 x 50	
⑳	013448	8	Washer ø13 x ø40 x 2	
㉑	012969	8	Rubber washer, ø12 x ø40 x 6	
㉒	011077	4	Nyloc nut M12	

Hydraulic tank and fittings

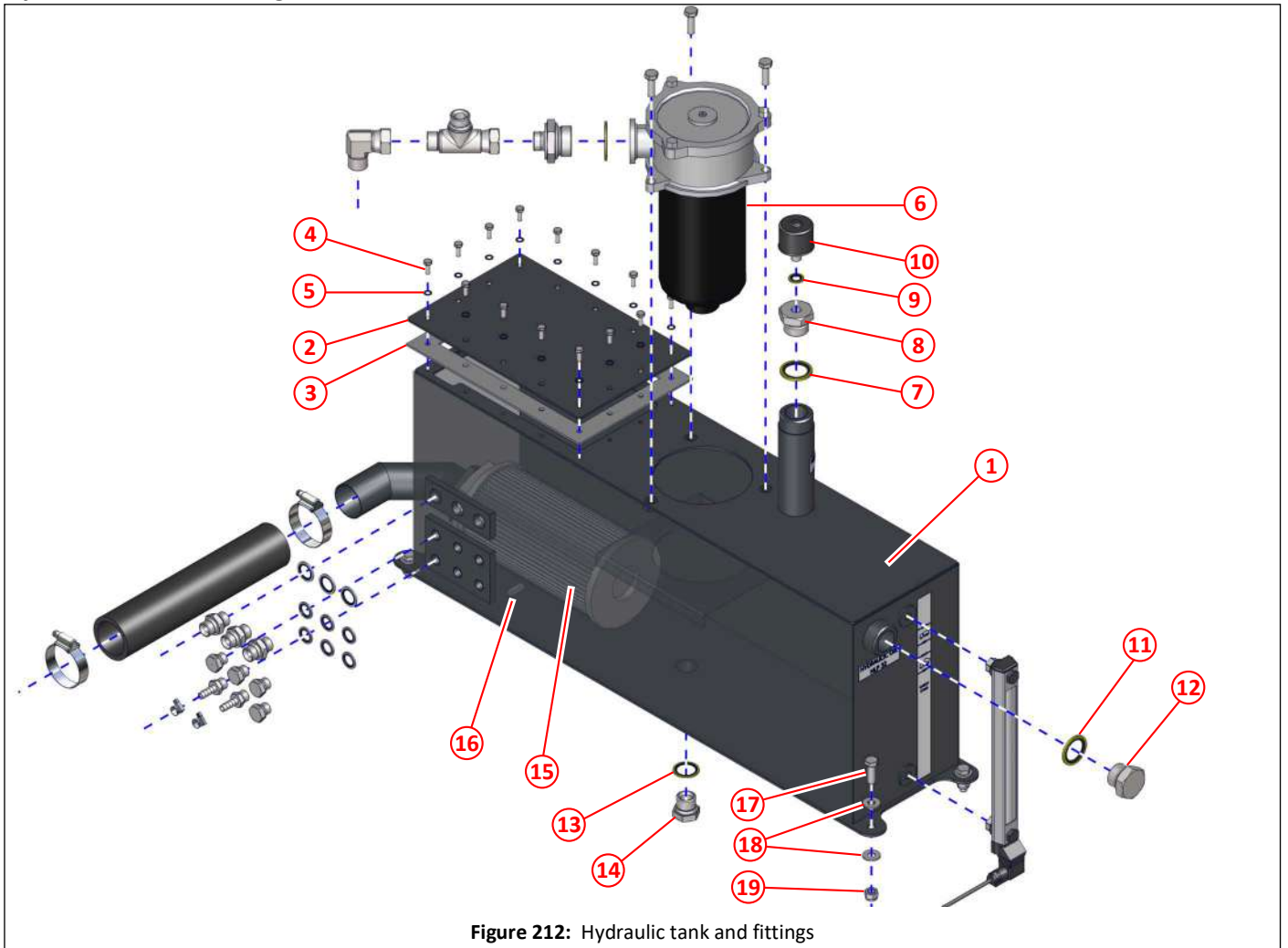

Figure 212: Hydraulic tank and fittings

Item	Part No	Qty	Description	
①	042818	1	Oil tank, hydraulic	339,250
②	042824	1	Lid, oil tank	
③	042866	1	Gasket, oil tank	
④	011001	14	Set screw M6 x 16	
⑤	000309	14	Lock washer, M6, zinc	
⑥	013123	1	Filter, return, includes filter element	250
⑦	011156	1	Dowty seal 1" BSP	
⑧	020689	1	Filler plug	
⑨	011152	1	Dowty seal 1/4" BSP	
⑩	020688	1	Filter, air breather	
⑪	011156	1	Dowty seal 1" BSP	
⑫	011136	1	Plug 1" BSP	
⑬	011155	1	Dowty seal 3/4" BSP	
⑭	011244	1	Plug 3/4" BSP	
⑮	020687	1	Filter. element, suction	
⑯	010305	1	Magnet	
⑰	011032	4	Set screw M10 x 30	
⑱	011094	8	Plain washer M10	
⑲	011075	4	Nyloc nut M10	

Hydraulic tank and fittings

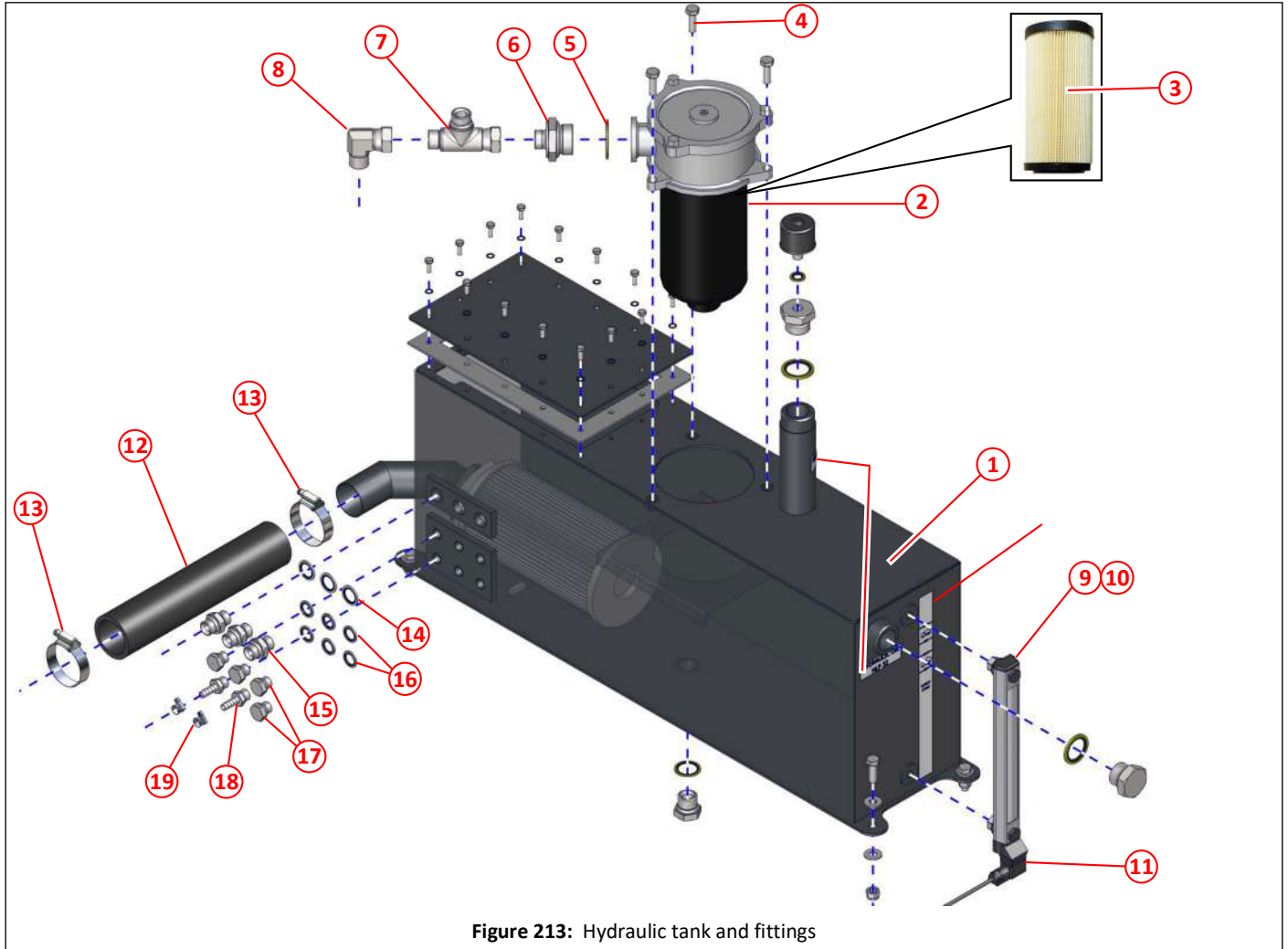

Figure 213: Hydraulic tank and fittings

Item	Part No	Qty	Description	
①	042818	1	Oil tank, hydraulic	339,249
②	013123	1	Filter, return, includes filter element	
③	013125	1	Element, return filter	
NI	024405	1	Seal kit, return filter	
④	011032	3	Set screw M10 x 30	
⑤	011150	1	Dowty seal 1 1/4" BSP	
⑥	011184	1	Adapter 1 1/4" BSP x 3/4" BSP reducer	
⑦	011197	1	Tee, 3/4" BSP, nut on run, branch return from suction fan circuit	
⑧	011174	1	Elbow, swivel, 3/4" BSP, connection return from suction fan	
⑨	024039	1	Level gauge, with switch and fitting screws	
⑩	021979	2	Sealing washer	
⑪	036842	1	M12 plug/cable and valve, plug type B	
⑫	031272	1	Hose 2" x 300, suction, to hydraulic suction manifold	251
⑬	029778	2	Hose clamp, worm drive, high torque, (ø40-ø70)	
⑭	011154	3	Dowty seal 1/2" BSP	
⑮	011160	3	Adapter, M/M, 1/2" BSP	
⑯	011153	6	Dowty seal 3/8" BSP	
⑰	011242	4	Plug 3/8" BSP	
⑱	010923	2	Adapter, 3/8" BSP x 3/8" hose tail	
⑲	010516	2	Hose clamp, worm drive, No. M00 (ø11mm-ø16mm)	

Hydraulic suction manifold

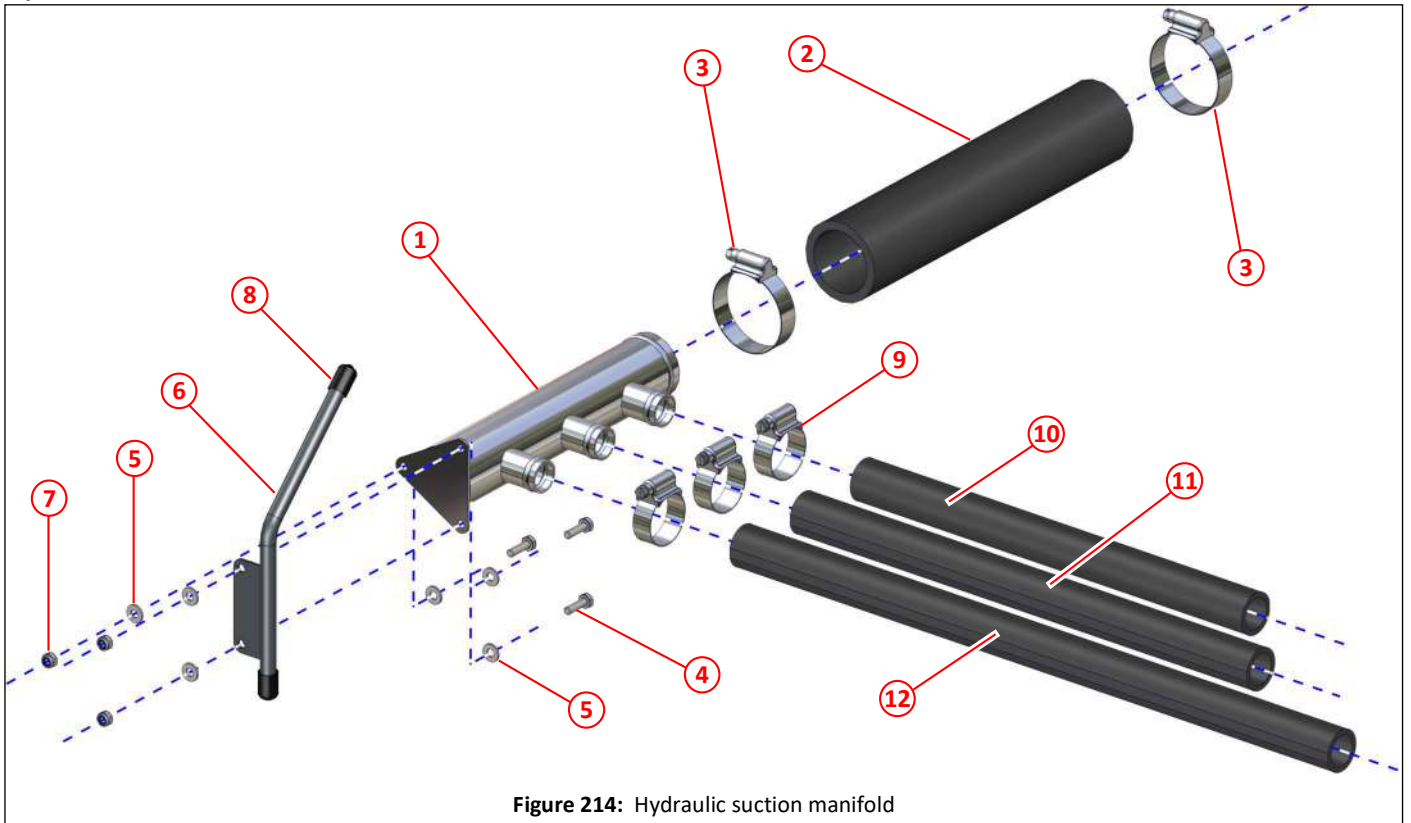

Figure 214: Hydraulic suction manifold

Item	Part No	Qty	Description
①	043305	1	Manifold, hydraulic suction
②	031272	1	Hose 2" x 300, suction, from hydraulic oil tank
③	029778	2	Hose clamp, worm drive, high torque, (ø40-ø70)
④	011067	3	Set screw M6 x 20
⑤	011090	6	Plain washer M6
⑥	043362	1	Bracket, loom rail
⑦	011071	3	Nyloc nut M6
⑧	043065	2	Pipe cap, ø12
⑨	014828	3	Hose clamp, worm drive, high torque, (ø25-ø40)
⑩	043769	1	Hose, supply from manifold to fan pump
⑪	043770	1	Hose, supply from manifold to gear pump 1
⑫	043771	1	Hose, supply from manifold to gear pump 2



Fan pump and gear pumps, general arrangement

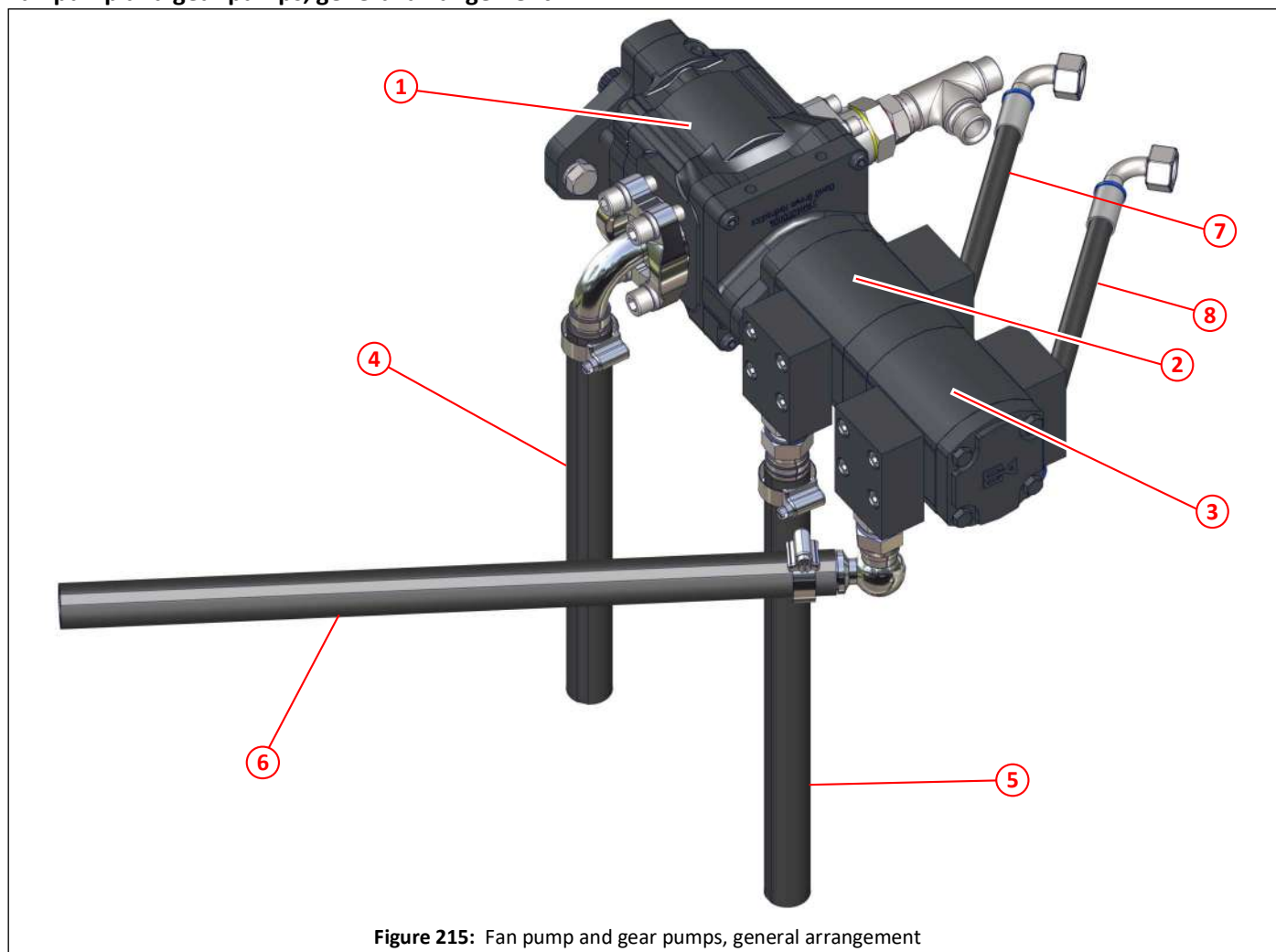

Figure 215: Fan pump and gear pumps, general arrangement

Item	Part No	Qty	Description	
①	043301	1	Fan pump	253
②			Gear pump 1	254
③			Gear pump 2	254
④	043769	1	Hose, supply from manifold to fan pump	
⑤	043770	1	Hose, supply from manifold to gear pump 1	
⑥	043771	1	Hose, supply from manifold to gear pump 2	
⑦	001261	1	Hose, 1/2" BSP x 350, 90°/90° 270° rotation, to flow control valve block Port P1	
⑧	001261	1	Hose, 1/2" BSP x 350, 90°/90° 270° rotation, to flow control valve block Port P2	



Fan pump and fittings

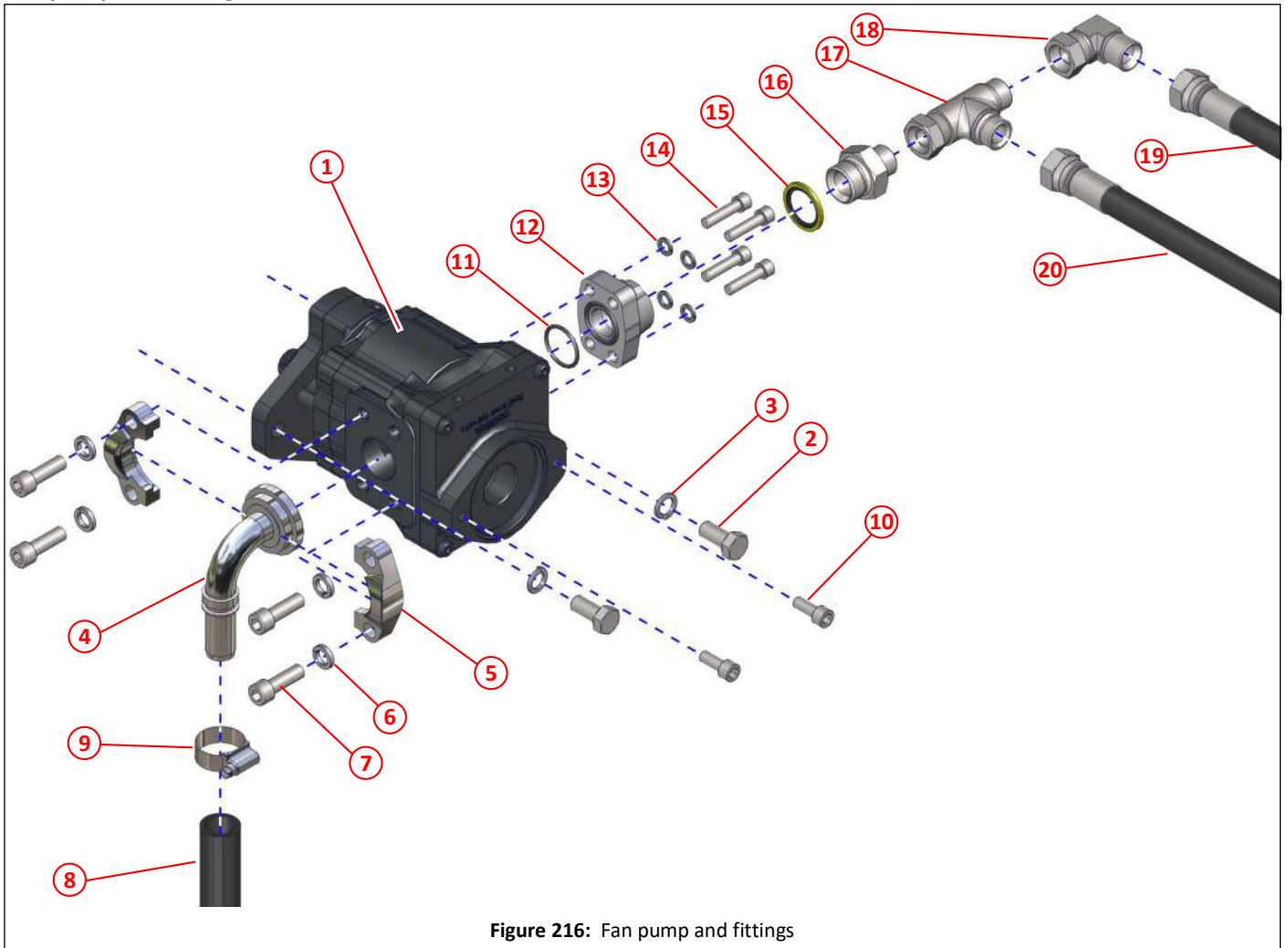

Figure 216: Fan pump and fittings

Item	Part No	Qty	Description	
①	043301	1	Fan pump	252
②	000477	2	Set screw M14 x 30	
③	011106	2	Spring washer M14	
④	011231	1	Elbow, swept, 1½" SAE x 1" hose tail	
⑤	011230	2	Flange, split, 1½" SAE	
⑥	011046	4	Spring washer, ½"	
⑦	011108	4	Socket cap head screw ½" UNC X 1½"	
⑧	043769	1	Hose, supply from manifold to fan pump	
⑨	014828	1	Hose clamp, worm drive, high torque, (ø25-ø40)	
⑩	011028	2	Socket cap head screw M10 x 25	
⑪	013517	1	'O' ring 1" SAE BS 219	
⑫	014105	1	Flange, 1" SAE x 1" BSP	
⑬	011406	4	Spring washer ¾" BSP	
⑭	000045	4	Socket cap head screw ¾" UNC x 1½"	
⑮	011156	1	Dowty seal 1" BSP	
⑯	011193	1	Adapter, M/M, 1" x ¾" BSP	
⑰	011197	1	Tee, ¾" BSP, nut on run	
⑱	011174	1	Elbow, swivel ¾" BSP	
⑲	001311	1	Hose, 5/8" BSP x 5700, ¾" BSP straight ends, to pipe connection at bottom of hopper for fan	
⑳	001310	1	Hose 5/8" BSP x 1630, ¾" BSP straight ends, to fan circuit valves	257,

Gear pumps and fittings

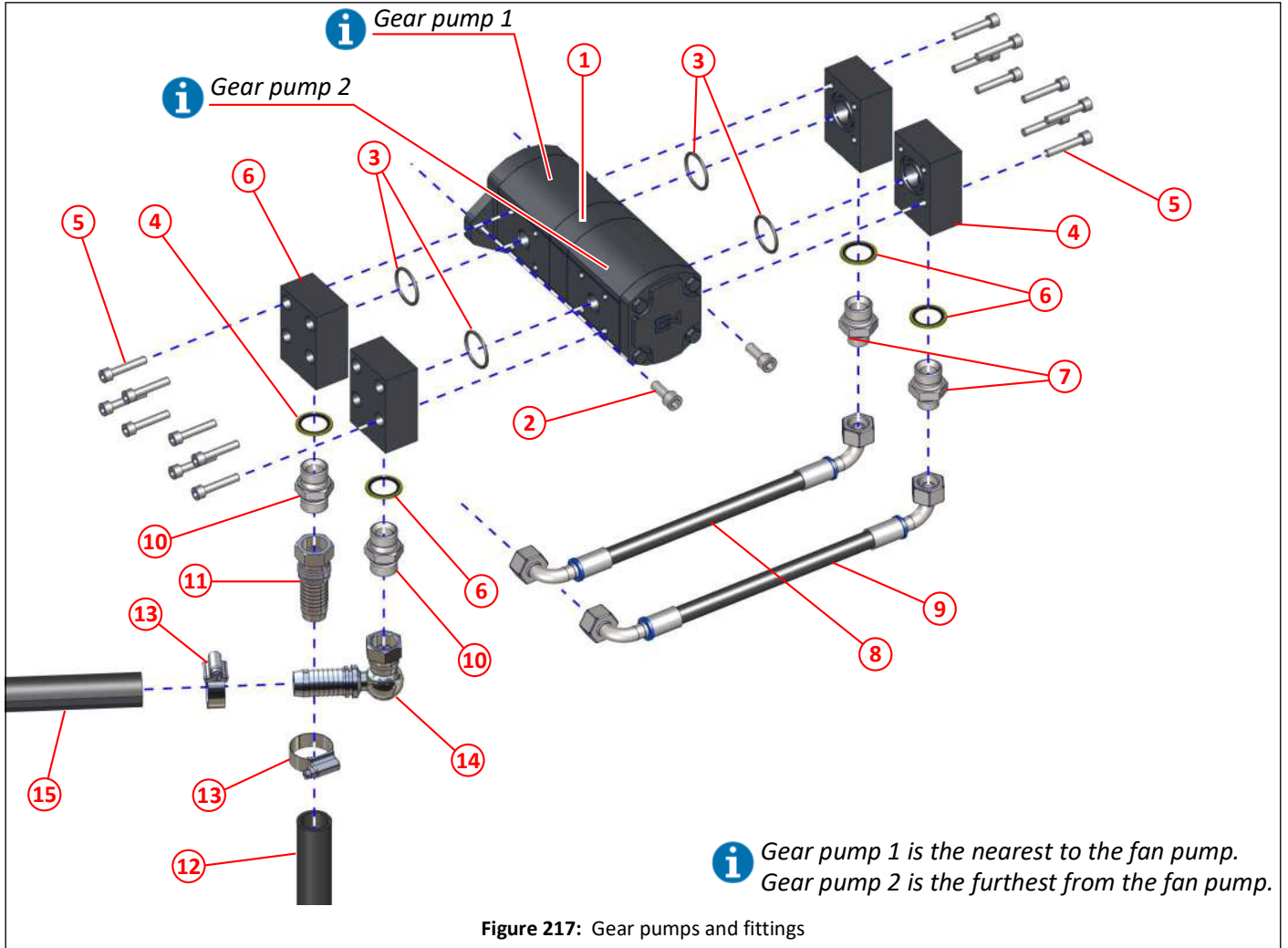

Figure 217: Gear pumps and fittings

Item	Part No	Qty	Description	
①	031970 *	1	Gear pump 23cc double	252
②	011028	2	Socket cap head screw M10 x 25	
③	013517	1	'O' ring 1" SAE BS 219	
④	026335	4	Adapter block, gear pump	
⑤	000096	16	Socket cap head screw M8 x 40	
⑥	011155	4	Dowty seal $\frac{3}{4}$ " BSP	
⑦	011166	2	Adapter, M/M, $\frac{3}{4}$ " BSP x $\frac{1}{2}$ " BSP	
⑧	001261	1	Hose, $\frac{1}{2}$ " BSP x 350, 90°/90° 270°. to flow control valve block Port P1	
⑨	001261	1	Hose, $\frac{1}{2}$ " BSP x 350, 90°/90° 270°, to flow control valve block Port P2	
⑩	011161	2	Adapter, M/M, $\frac{3}{4}$ " BSP	
⑪	002084	1	Adapter, $\frac{3}{4}$ " BSPF x 1" hose tail	
⑫	043770	1	Hose, supply from manifold to gear pump 1	
⑬	014828	2	Hose clamp, worm drive, high torque, ( $\phi 25$ - $\phi 40$ )	
⑭	002203	1	Elbow, $\frac{3}{4}$ " BSP x 1" hose tail	
⑮	043771	1	Hose, supply from manifold to gear pump 2	

NI *	030629	1	Seal kit, gear pump 23cc double
*	031971	1	Gear pump 23cc single
NI *	030628	1	Seal kit, gear pump 23cc single

Flow control valves and fittings

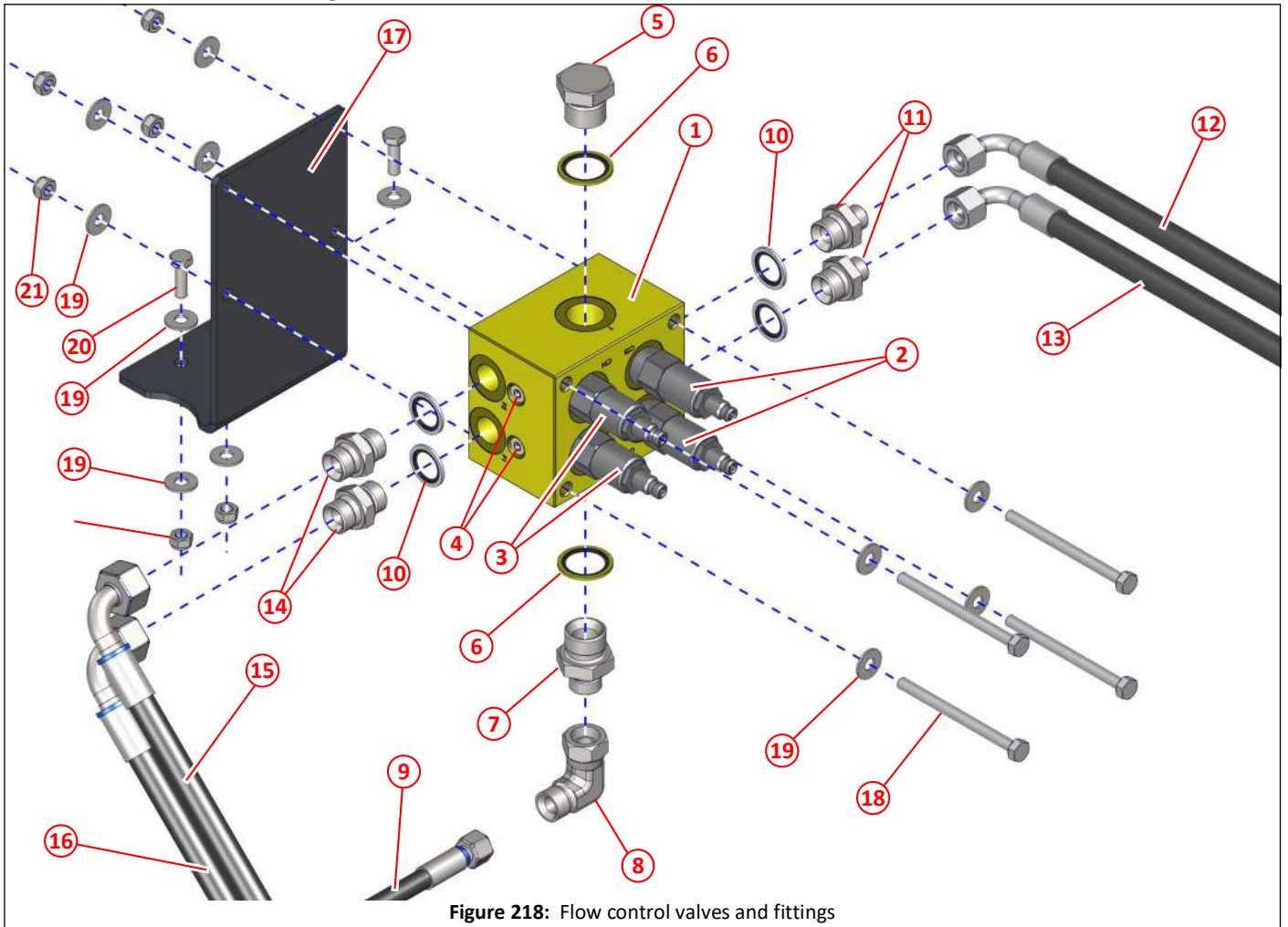

Figure 218: Flow control valves and fittings

Item	Part No	Qty	Description
①	038513	1	Flow control valve block, dual, remote mounted, includes items ②, ③ and ④
②	040288	2	Flow regulator (PFR2-10-S-0-9.00)
③	039063	2	Relief valve (RV1-10-S-36/30.5)
④	039061	2	Plug, hex, hollow, 1/4" SAE
⑤	011244	1	Plug 3/4" BSP
⑥	011155	2	Dowty seal 3/4" BSP
⑦	011166	1	Adapter, M/M, 3/4" BSP x 1/2" BSP
⑧	011173	1	Elbow, swivel, M/F, 1/2" BSP
⑨	001037	1	Hose, 1/4" x 2650, 1/2" BSP straight and 90° ends, to oil tank
⑩	011154	4	Dowty seal 1/2" BSP
⑪	011167	2	Adapter, M/M, 1/2" BSP x 3/8" BSP
⑫	002092	1	Hose, 3/8" x 340, 3/8" BSP straight and 90° ends, from port B to top hydraulic filter
⑬	001327	1	Hose, 3/8" x 310, 90° ends, 180° rotation, from port A to lower hydraulic filter
⑭	011160	2	Adapter, M/M, 1/2" BSP
⑮	001261	1	Hose, 1/2" BSP x 350, 90°/90° 270°. from gear pump 2 to flow control valve block Port P2
⑯	001261	1	Hose, 1/2" BSP x 350, 90°/90° 270°, from gear pump 2 to flow control valve block Port P1
⑰	043123	1	Bracket, remote flow control
⑱	011020	4	Bolt M8 x 100
⑲	011092	12	Plain washer M8
⑳	011011	2	Set screw M8 x 25
㉑	011073	6	Nyloc nut M8

Hydraulic high pressure oil filters and fittings

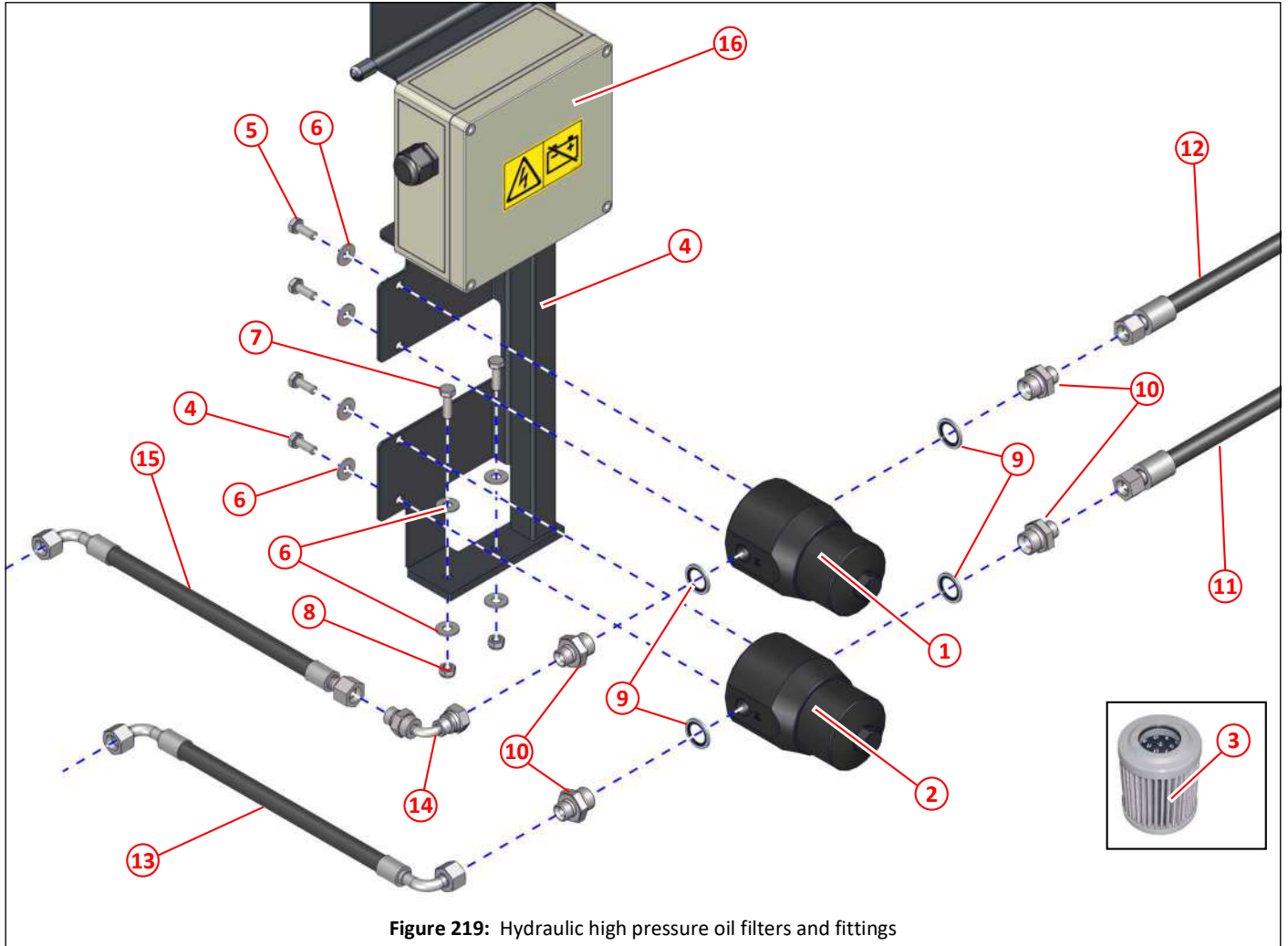

Figure 219: Hydraulic high pressure oil filters and fittings

Item	Part No	Qty	Description	
①	025103	1	Filter, high pressure, complete with filter element, for option valve block	
②	025103	1	Filter, high pressure, complete with filter element, for main valve block	
③	025104	1	Filter element for 025103	
④	042957	1	Bracket, junction box and filters	
⑤	011010	4	Set screw M8 x 20	
⑥	011092	8	Plain washer M8	
⑦	011011	2	Set screw M8 x 25	
⑧	011073	2	Nyloc nut M8	
⑨	011154	4	Dowty seal 1/2" BSP	
⑩	011167	4	Adapter, M/M, 1/2" BSP x 3/8" BSP	
⑪	011306	1	Hose, 3/8" x 1400, 3/8" BSP straight ends, to Port P on main valve block	
⑫	001167	1	Hose, 3/8" x 1200, 3/8" BSP straight ends, to Port P on options valve block	
⑬	001327	1	Hose, 3/8" x 310, 90° ends, 180° rotation, from Port A on flow control block	255
⑭	011221	1	Elbow, swept, M/F, 3/8" BSP	
⑮	002092	1	Hose, 3/8" x 340, 3/8" BSP straight and 90° ends, from Port B on flow control block	255
⑯	043380	1	Junction box assembly, 24v	327
⑰	044537	1	Junction box assembly, 12v	327



Suction fan and suction nozzle tilt control circuits, general arrangement

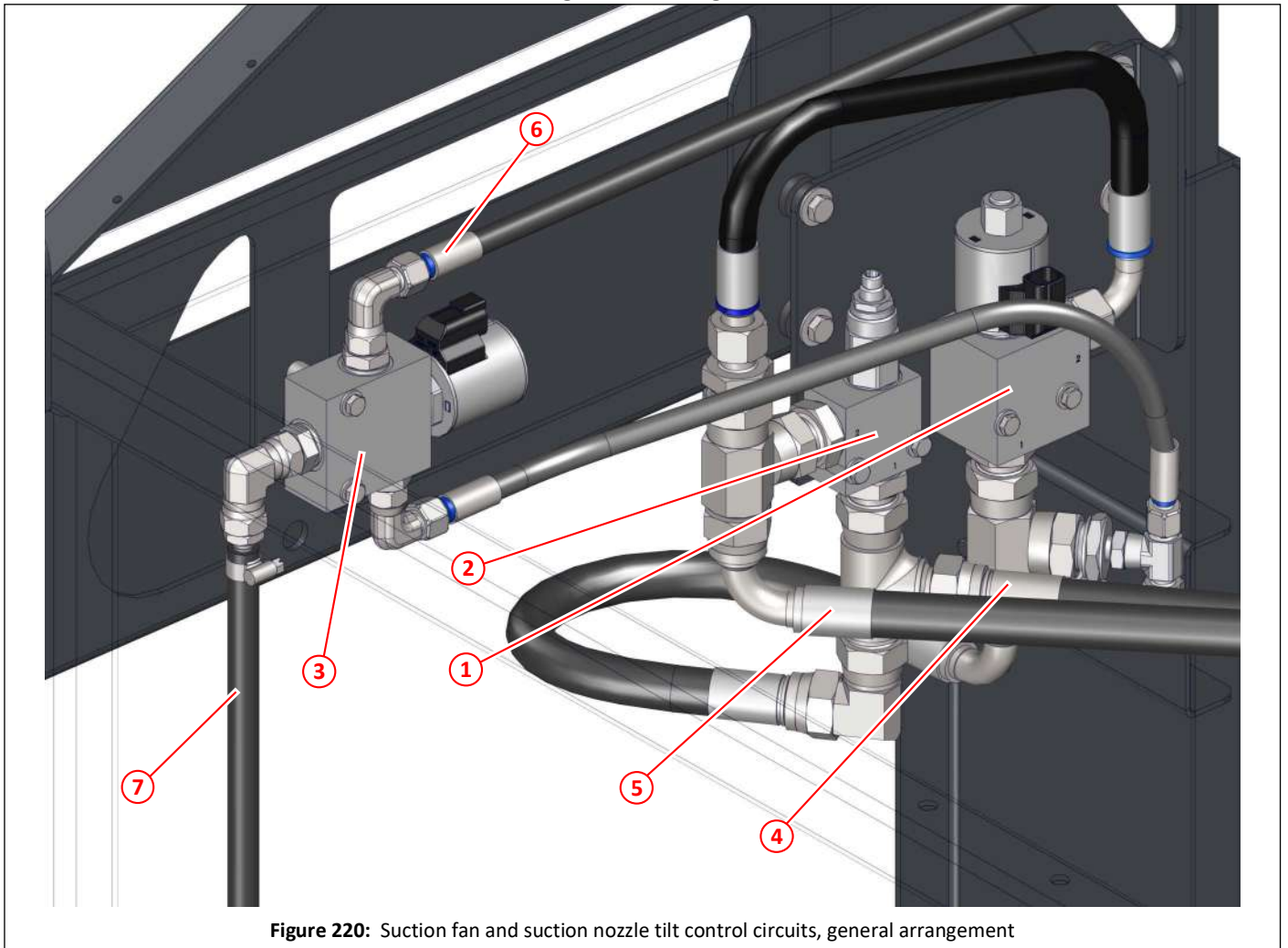

Figure 220: Suction fan and suction nozzle tilt control circuits, general arrangement

Item	Part No	Qty	Description	
①		1	Dump valve, suction fan control	258, 259
②	041951	1	Relief valve, suction fan control	258, 259
③	041953	1	Control valve, suction nozzle tilt, 24v	260
③	044490	1	Control valve, suction nozzle tilt, 12v	260
④	001310	1	Hose $\frac{5}{8}$ " x 1630, $\frac{3}{4}$ " BSP straight ends, from suction fan pump	253
⑤	001306	1	Hose $\frac{5}{8}$ " x 1530, $\frac{5}{8}$ " BSP straight and 90° ends, to return filter on oil tank	249, 250
⑥	001151	1	Hose $\frac{1}{4}$ " x 3040, $\frac{1}{4}$ " BSP straight and 90° ends with 6mm elbow, to suction nozzle tilt ram(s)	
⑦	010958	As req	Hose $\frac{3}{8}$ ", return to tank	

Suction fan control circuit

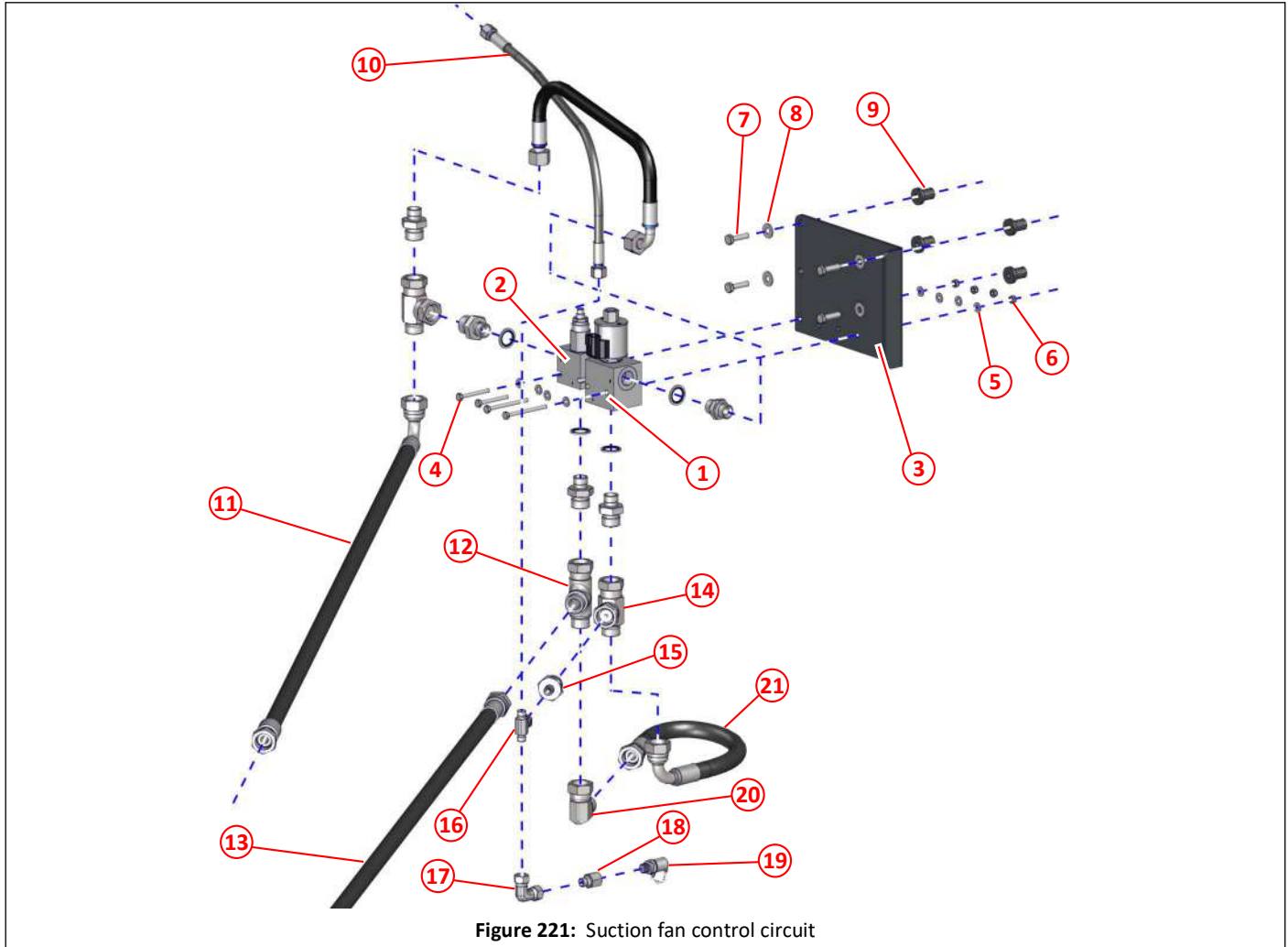

Figure 221: Suction fan control circuit

Item	Part No	Qty	Description	
①		1	Dump valve, suction fan control	259
②	041951	1	Relief valve, suction fan control	259
③	042491	1	Mounting bracket, suction fan control	
④	011003	4	Set screw M6 x 50	
⑤	011090	8	Plain washer M6	
⑥	011071	4	Nyloc nut M6	
⑦	011012	4	Set screw M8 x 30	
⑧	011092	4	Plain washer M8	
⑨	0393392	4	Fastener, M8, Flex-loc anti-vibration	
⑩	010990	1	Hose 1/4" x 600, 1/4" BSP straight ends, to suction nozzle tilt control	260
⑪	001306	1	Hose 5/8" x 1530, 5/8" BSP straight and 90° ends, to return filter on oil tank	
⑫	011197	1	Tee, 3/4" BSP, nut on run	
⑬	001310	1	Hose 5/8" x 1630, 3/4" BSP straight ends, from suction fan pump	
⑭	002233	1	Tee, M/F/F, 3/4" BSP, nut on branch and on run	
⑮	011164	1	Adapter, M/M, 3/4" BSP x 3/4" BSP	
⑯	002009	1	Tee, 1/4" BSP, nut on branch	
⑰	011169	1	Elbow, swivel, F/F, 1/4" BSP	
⑱	002014	1	Adapter, Fixed M/F, 1/4" BSP	
⑲	013036	1	Test point, 1/4" BSP	
⑳	011174	1	Elbow, swivel, M/F, 3/4" BSP	
㉑	001238	1	Hose 5/8" x 420, 3/4" BSP straight and 90° ends	



Suction fan control circuit

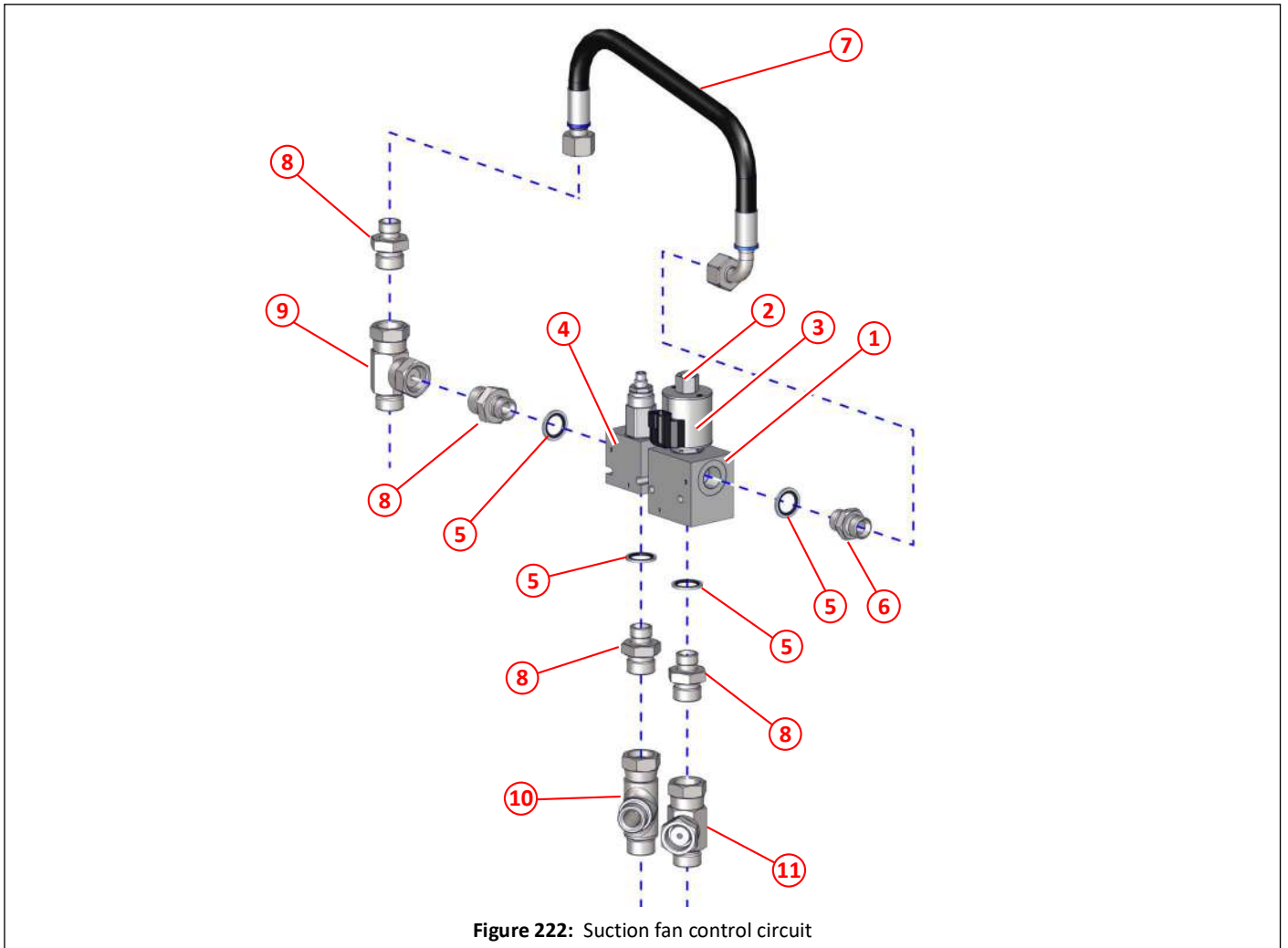

Figure 222: Suction fan control circuit

Item	Part No	Qty	Description
①	041952	1	Dump valve, suction fan control, complete with items ② and ③, 24v
①	044488	1	Dump valve, suction fan control, complete with items ② and ③, 12v
②	044498	1	Solenoid HSV10-29-0-U-00
③	044048	1	Coil, 4304124 E SERIES, 24v
③	041224	1	Coil, 4304112 E SERIES, 12v
④	041951	1	Relief valve, suction fan control
⑤	011154	4	Dowty seal 1/2" BSP
⑥	011160	1	Adapter, M/M, 1/2" BSP
⑦	001075	1	Hose, 1/2" x 500, 1/2" BSP straight and 90° ends
⑧	011166	4	Adapter, M/M, 3/4" BSP X 1/2" BSP
⑨	002233	1	Tee, M/F/F, 3/4" BSP, nut on branch and on run
⑩	011197	1	Tee, 3/4" BSP, nut on run
⑪	002233	1	Tee, M/F/F, 3/4" BSP, nut on branch and on run

Suction nozzle tilt control valve

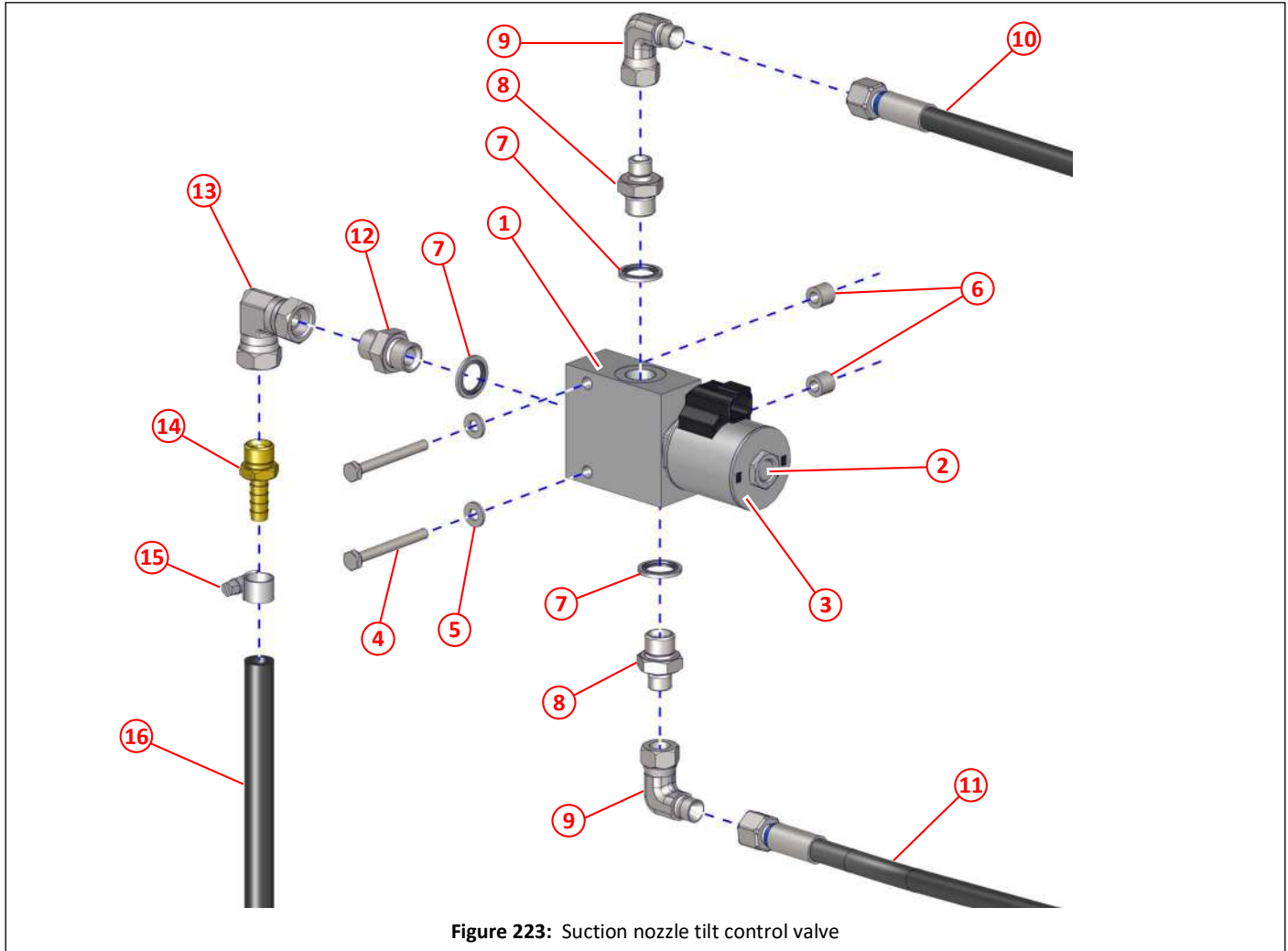

Figure 223: Suction nozzle tilt control valve

Item	Part No	Qty	Description	
①	041953	1	Control valve, suction nozzle tilt, includes items ② and ③, 24v	257
①	044490	1	Control valve, suction nozzle tilt, includes items ② and ③, 12v	257
②	044499	1	Solenoid SV58-30-0-P-00	
③	044048	1	Coil, 4304124 E SERIES, 24v	
③	044497	1	Coil, 4392692 E SERIES, 12v	
④	000018	2	Set screw M6 x 55	
⑤	011090	2	Plain washer M6	
⑥	013344	2	Spacer, $\phi 6.5 \times \phi 12 \times 10$	
⑦	011153	3	Dowty seal $\frac{3}{8}$ " BSP	
⑧	011199	2	Adapter, M/M, $\frac{3}{8}$ " BSP x $\frac{1}{4}$ " BSP	
⑨	011171	2	Elbow, swivel, M/F, $\frac{1}{4}$ " BSP	
⑩	001151	1	Hose $\frac{1}{4}$ " x 3040, $\frac{1}{4}$ " BSP straight and 90° ends with 6mm elbow, to suction nozzle tilt ram(s)	
⑪	010990	1	Hose $\frac{1}{4}$ " x 600, $\frac{1}{4}$ " BSP straight ends, to Tee on suction fan control circuit, by test point	
⑫	011159	1	Adapter, M/M, $\frac{3}{8}$ " BSP	
⑬	011205	1	Elbow, swivel, F/F, $\frac{3}{8}$ " BSP	
⑭	010923	1	Adapter $\frac{3}{8}$ " BSP X $\frac{3}{8}$ " hose tail	
⑮	010516	1	Hose clamp, worm drive, No. M00 ( $\phi 11\text{mm}-\phi 16\text{mm}$ )	
⑯	010958	As req	Hose $\frac{3}{8}$ ", return to tank	

Suction fan motor

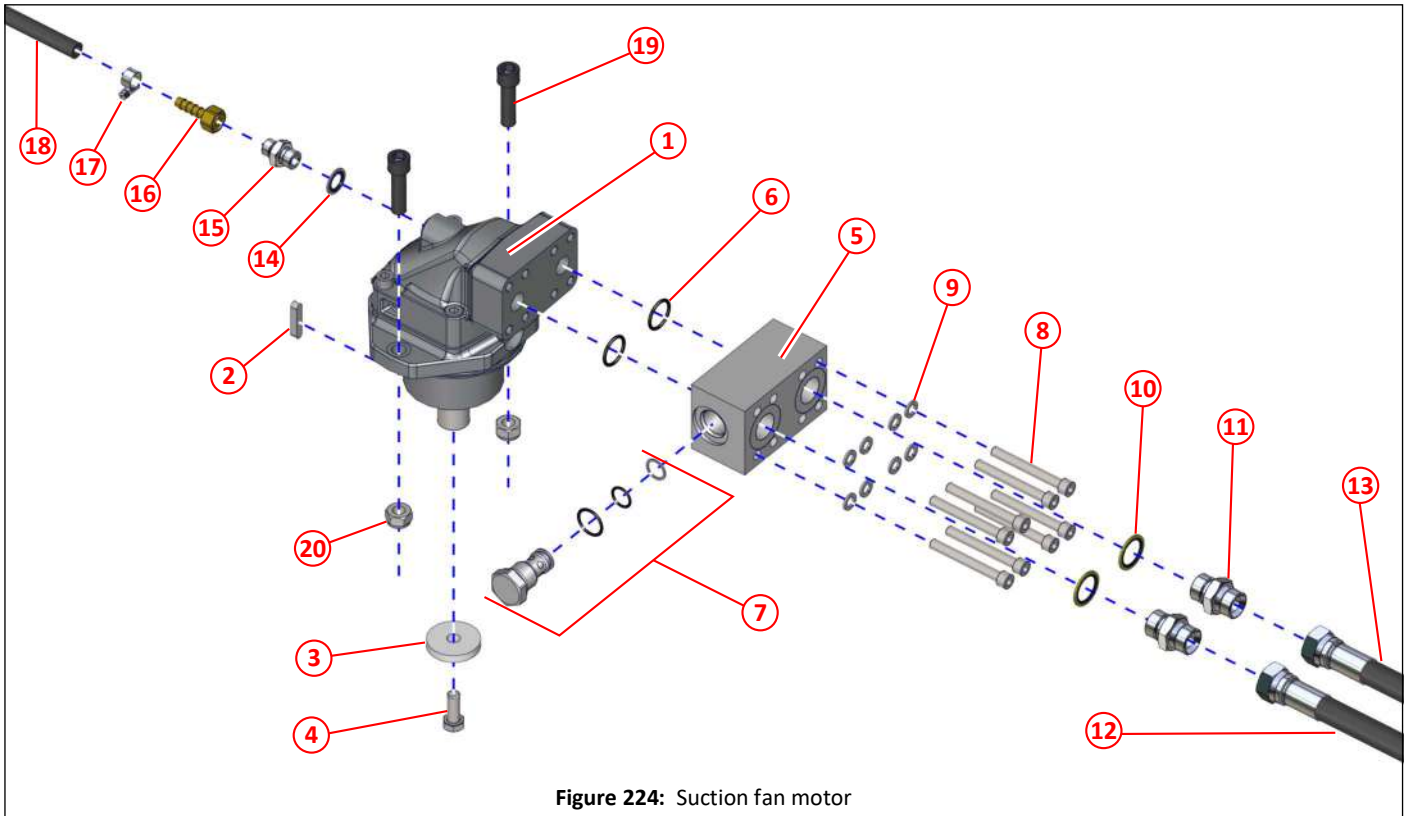

Figure 224: Suction fan motor

Item	Part No	Qty	Description	
①	024641	1	Fan motor	145
②	013292	1	Key for item ①	
③	044926	1	Washer $\phi 12.5 \times \phi 50 \times 8$ , stainless steel	
④	011052	1	Set screw M12 x 30	
⑤	041633 *	1	Manifold, anti-cavitation valve	
⑥	041634 *	2	'O' ring	
⑦	041635 *	1	Check valve, includes seals and washer	
⑧	000048	8	Socket cap head screw M10 x 80	
⑨	011095	8	Spring washer M10	
⑩	011155	2	Dowty seal $\frac{3}{4}$ " BSP	
⑪	011161	2	Adapter $\frac{3}{4}$ " BSP	
⑫	001322	1	Hose $\frac{5}{8}$ " x 1550, $\frac{3}{4}$ " BSP straight ends	
⑬	001323	1	Hose $\frac{5}{8}$ " x 1700, $\frac{3}{4}$ " BSP straight ends	
⑭	011247	1	Dowty seal M18	
⑮	011248	1	Adapter M18 x $\frac{3}{8}$ " BSP	
⑯	010921	1	Adapter $\frac{3}{8}$ " BSP x $\frac{3}{8}$ " hose tail, complete with but	
⑰	010516	1	Hose clamp, worm drive No. MOO ( $\phi 11\text{mm}-\phi 16\text{mm}$ )	
⑱	010958	As req	Hose $\frac{3}{8}$ "	
⑲	000343	2	Socket cap head bolt M14 x 50, black	
⑳	011127	2	Nyloc nut M14	

*	041564	1	Anti-cavitation valve assembly, includes items ⑤, ⑥ and ⑦	
---	--------	---	---	--

## Valve blocks, arrangement

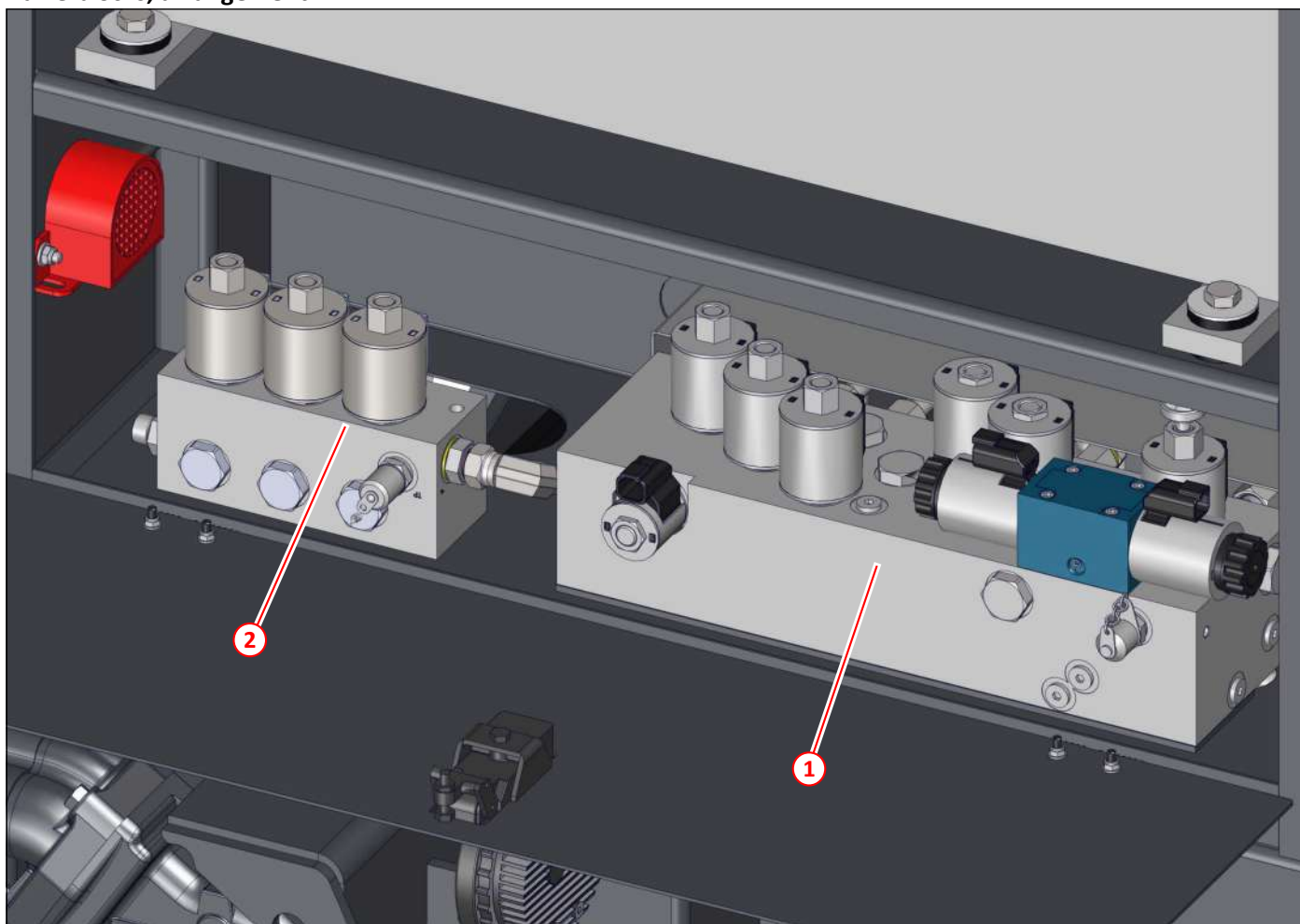

Figure 225: Valve blocks, arrangement

Item	Part No	Qty	Description	
①	042615	1	Main valve block, populated, 24v	263,265,265
①	044484	1	Main valve block, populated, 12v	263,265,265
②	042616	1	Options valve block, populated, 24v	266
②	044486	1	Options valve block, populated, 12v	266

Main valve block, coils, solenoids, check valves and plugs

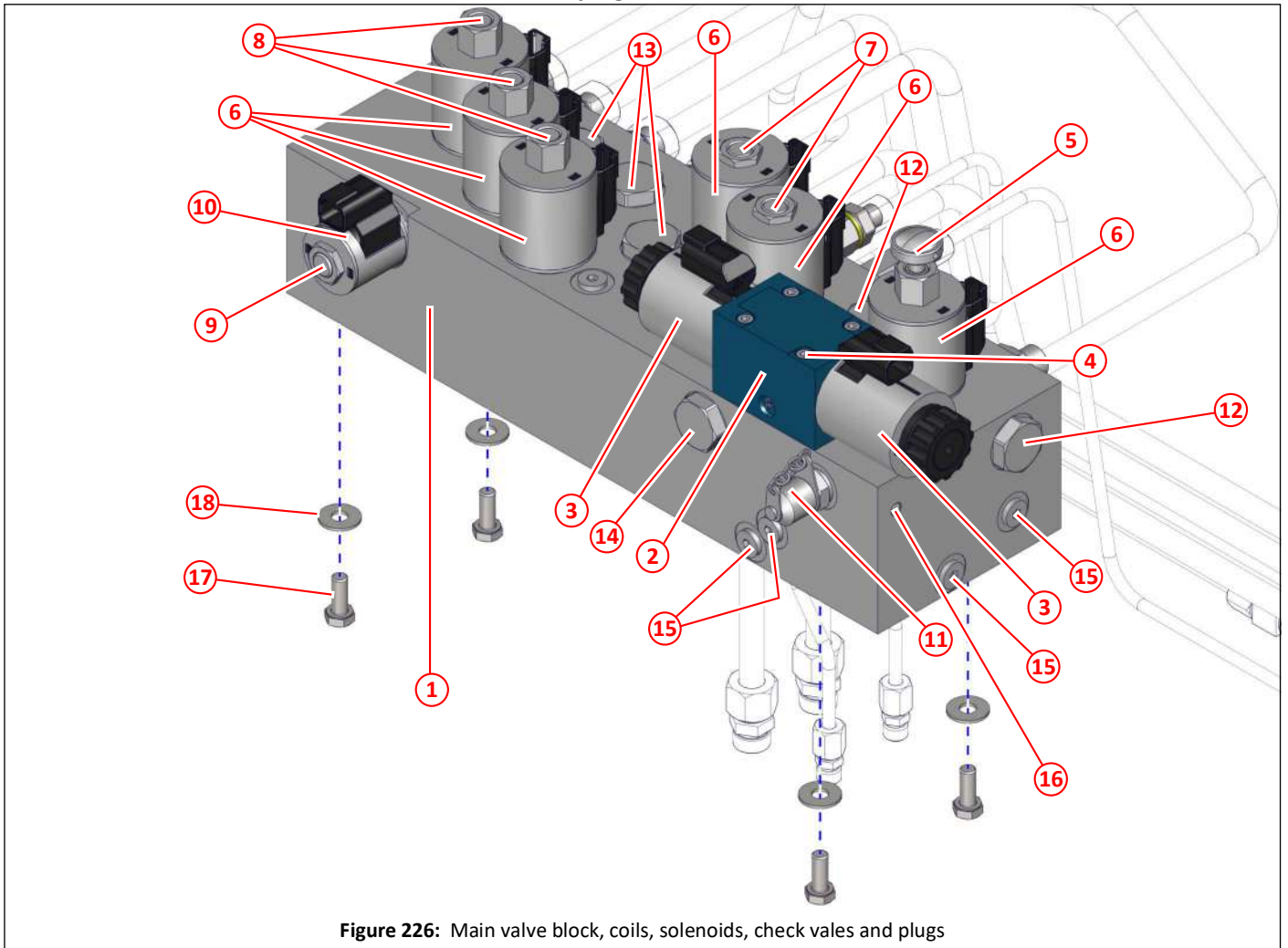

Figure 226: Main valve block, coils, solenoids, check vales and plugs

Item	Part No	Qty	Description	
①	044045	1	Main valve block, bare, 12v and 24v	262,264,265
②	044046	1	Directional control valve, SVD03-47C-N-00	
③	044047	2	Coil, 4302694 E SERIES 24v	
③	044497	2	Coil, 4302692 E SERIES, 12v	
④	044050	4	Cap head bolt	
⑤	044054	1	Manual override solenoid valve, SV10-21K-0-N-00	
⑥	044048	6	Coil, 4304124 E SERIES, 24v	
⑥	041224	6	Coil 20.5 watts, 12v	
⑦	044052	2	Solenoid valve, SV10-20-0-N-00	
⑧	044053	3	Solenoid valve, SV10-21-0-N-00	
⑨	044051	1	Solenoid valve, SP08-20-0-N-00	
⑩	044049	1	Coil, 4304024 E SERIES, 24v	
⑩	041225	1	Coil, 17.2 watts, with diode, 12v	
⑪	013036	1	Test point adapter	
⑫	044056	2	Cavity plug, CP10-20-N	
⑬	044055	3	Cartridge check valve, CV10-20-0-N-100	
⑭	045534	1	Cartridge check valve, CV10-2-0-N-05	
⑮	044058	18	SAE plug	
⑯	044059	1	Expander plug	
⑰	011010	4	Set screw M8 x 20	
⑱	011092	4	Plain washer M8	



Main valve block, fittings

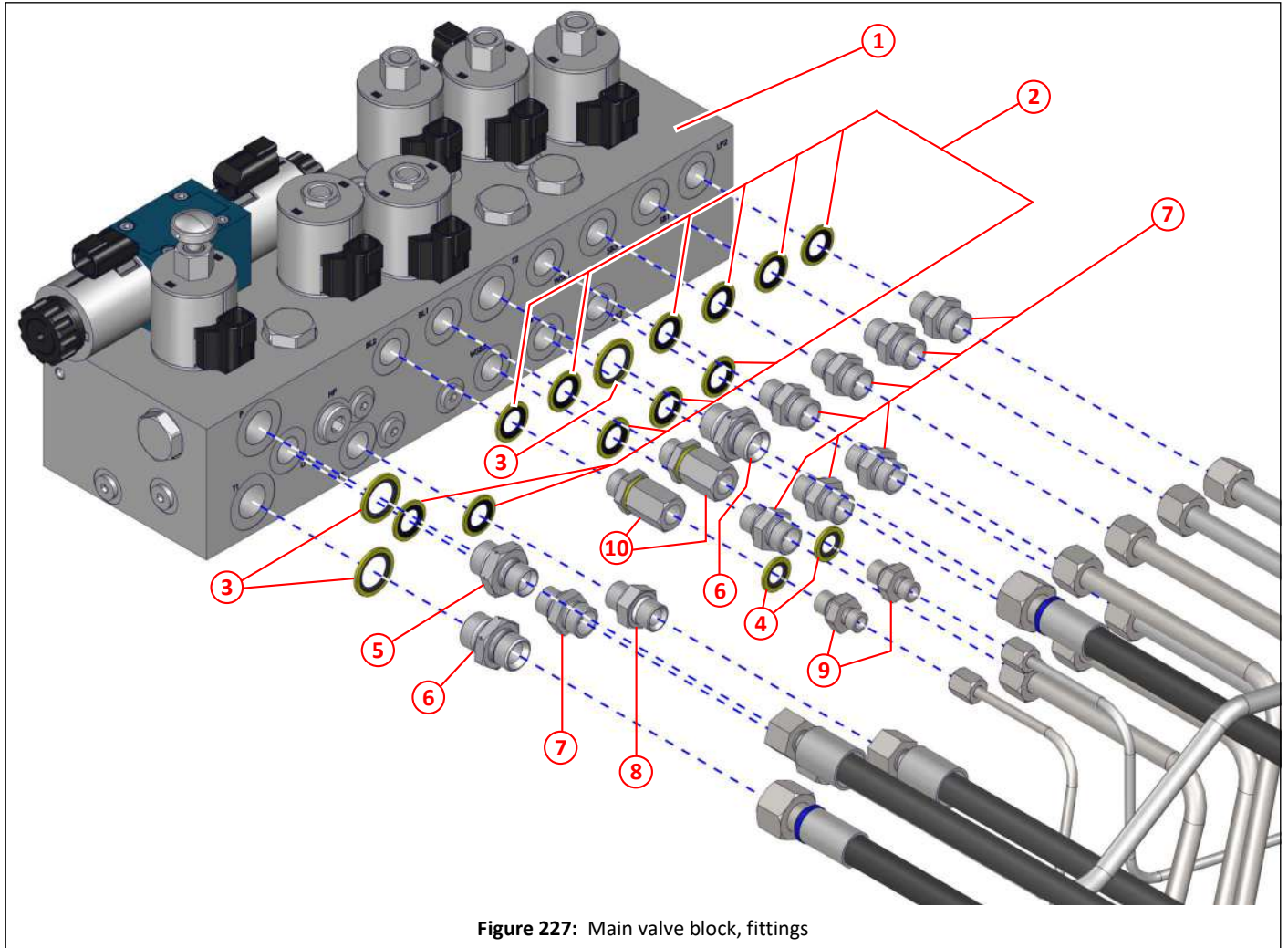

Figure 227: Main valve block, fittings

Item	Part No	Qty	Description	
①	042615	1	Main valve block, populated, 24v	262,263,265
①	044484	1	Main valve block, populated, 12v	262,263,265
②	011217	11	Dowty seal M16	
③	011267	2	Dowty seal M20	
④	011152	3	Dowty seal 1/4" BSP	
⑤	011266	1	Adapter M20 x 1.5 to 3/8" BSP	
⑥	037741	2	Adapter, M/M, 1/2" BSP to M20 x 1.5	
⑦	002175	8	Adapter, M16 x 1.5, 12 long	
⑧	011186	1	Adapter, M16 x 1.5 to 3/8" BSP	
⑨	020902	2	Adapter, 1/4" BSP, 6 long	
⑩	002176	2	Adapter, M/F, M16 x 1.5 to 1/4" BSP, 2 parts (adapter M/M and adapter F/F)	
NI	011152	2	Dowty seal 1/4" BSP, for use with item ⑩	



Main valve block, pipes and hoses

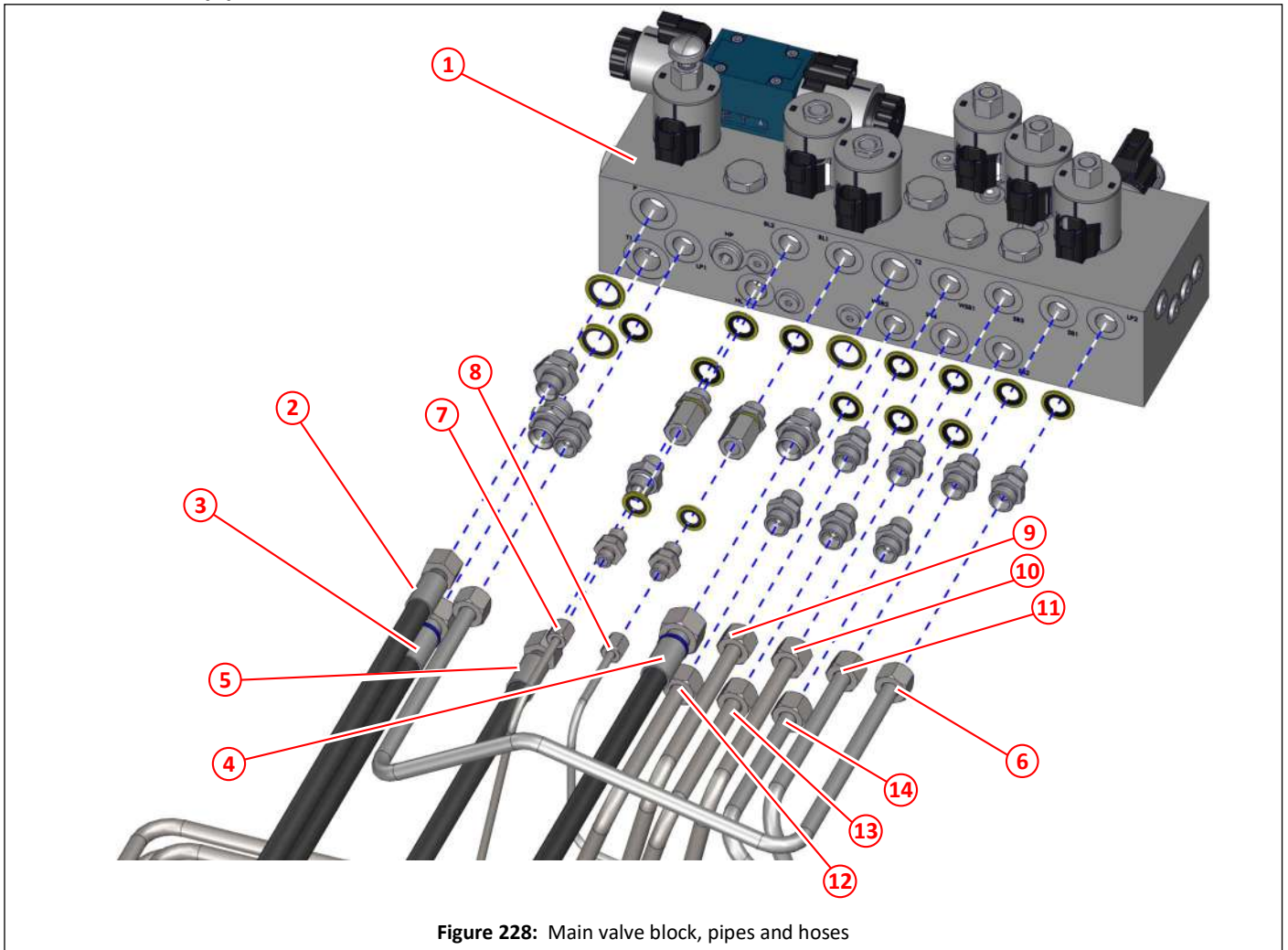

Figure 228: Main valve block, pipes and hoses

Item	Part No	Qty	Description	
①	042615	1	Main valve block, populated, 24v	262,263,264
①	044484	1	Main valve block, populated, 12v	262,263,265
②	011306	1	Hose, $\frac{3}{8}$ " x 1400, $\frac{3}{8}$ " BSP straight ends, from oil filter to Port P	
③	001271	1	Hose, $\frac{1}{2}$ " BSP x 960, straight and 90° ends, from oil cooler to Port T1	
④	001328	1	Hose, $\frac{1}{2}$ " BSP x 810, straight and 90° ends, from oil cooler to Port T2	
⑤	011311	1	Hose, $\frac{3}{8}$ " x 1100, $\frac{3}{8}$ " BSP straight ends, from hand pump/hopper control valve to Port HL	
⑥	040127	1	Link pipe, steel, Ports LP1 to LP2	
⑦	043409	1	Pipe, steel, left hand brush lift, to Port BL2	
⑧	043414	1	Pipe, steel, right hand brush lift, to Port BL1	
⑨	043416	1	Pipe, steel, central brush (wide sweep) feed, to Port WSB1	
⑩	043405	1	Pipe, steel, left hand brush feed, to Port SB3	
⑪	043412	1	Pipe, steel, right hand brush feed, to Port SB1	
⑫	043418	1	Pipe, steel, central brush (wide sweep) return, to Port WSB2	
⑬	043407	1	Pipe, steel, left hand brush return, to Port SB4	
⑭	043413	1	Pipe, steel, right hand brush return, to Port SB2	

## Options valve block, coils and solenoids

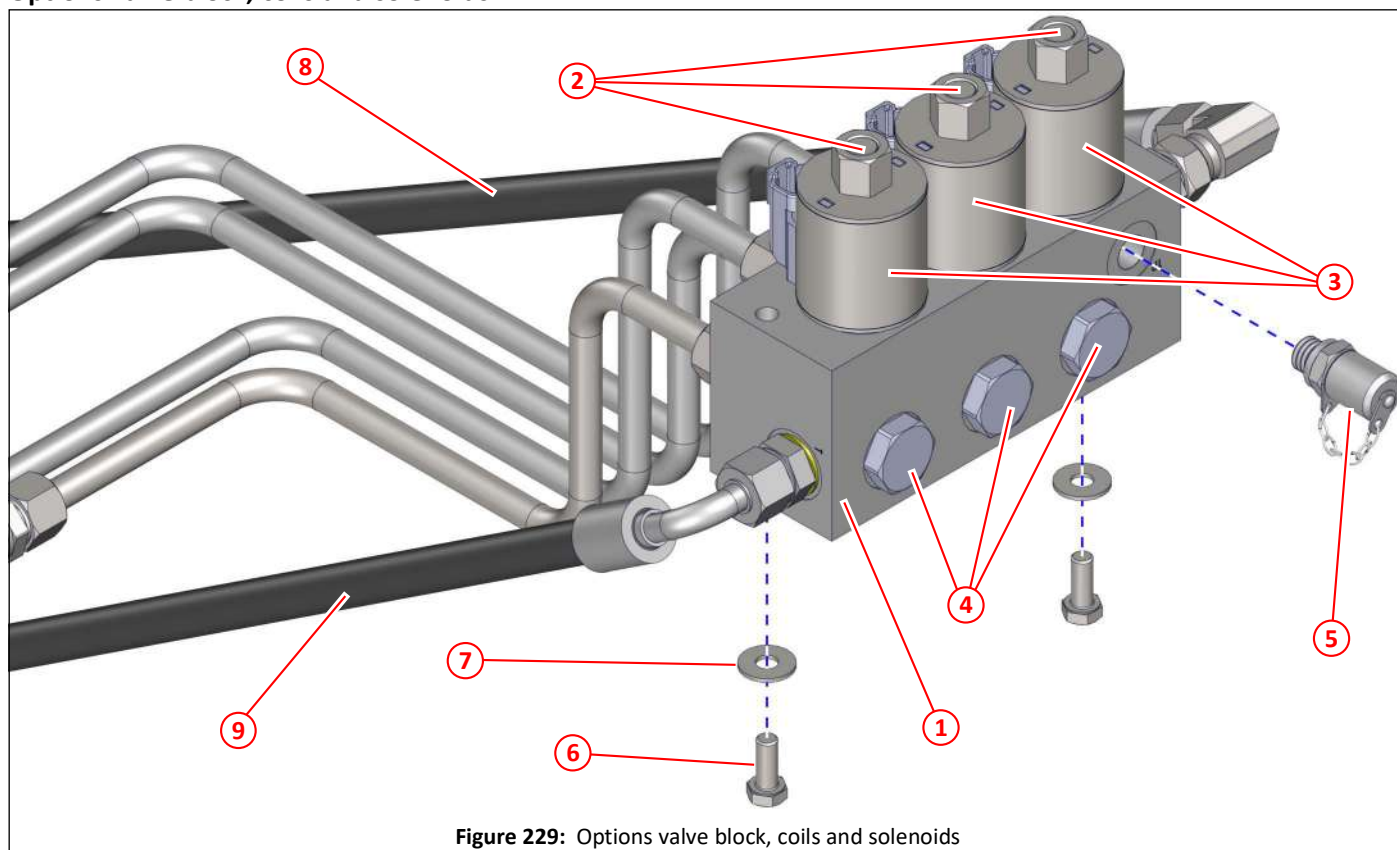

Figure 229: Options valve block, coils and solenoids

Item	Part No	Qty	Description	
①	042616	1	Options valve block, populated, 24v	262,267
①	044486	1	Options valve block, populated, 12v	262,267
②	044053	3	Solenoid valve, SV10-21-0-N-00	
③	044048	3	Coil, 4304124 E SERIES, 24v	
③	041224	3	Coil, 20.5 watts, 12v	
④	044055	3	Cartridge check valve, CV10-20-0-N-100	
⑤	013036	1	Test point adapter, 1/4" BSP	
⑥	011010	4	Set screw M8 x 20	
⑦	011092	4	Plain washer M8	
⑧	001167	1	Hose, 3/8" x 1200, 3/8" BSP straight ends, from HP oil filter to Port P	
⑨	001226	1	Hose, 3/8" x 530, 3/8" BSP straight and 90° ends, from Port T to oil tank	

Options valve block, fittings, pipes and hoses

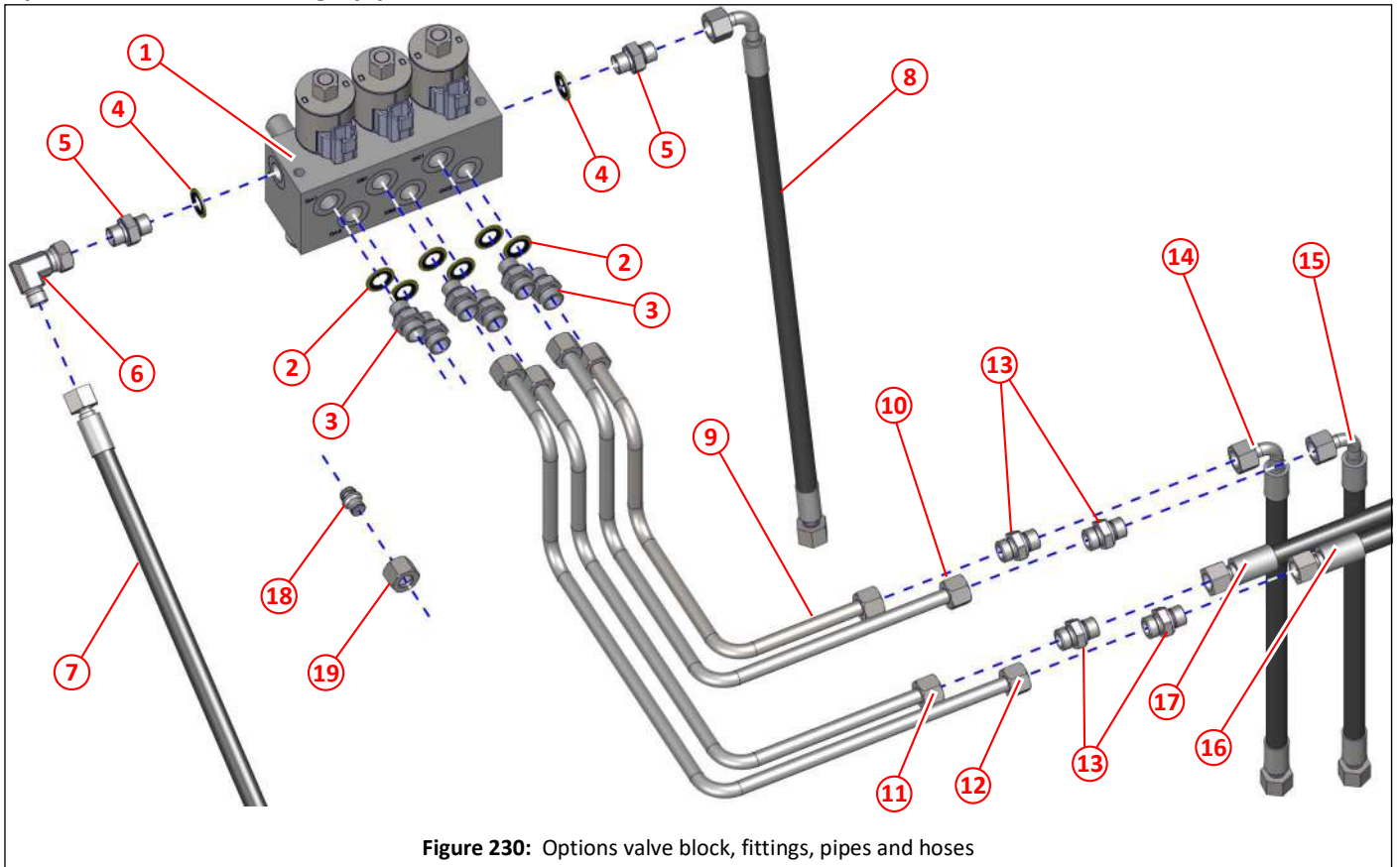

Figure 230: Options valve block, fittings, pipes and hoses

Item	Part No	Qty	Description	
①	042616	1	Options valve block, populated, 24v	262,266
①	044486	1	Options valve block, populated, 12v	262,266
②	011217	6	Dowty seal M16	
③	002175	6	Adapter, M16 x 1.5, 12 long	
④	011217	1	Dowty seal M16	
⑤	011186	2	Adapter, M16 x 1.5 to 3/8" BSP	
⑥	011172	1	Elbow, swivel, M/F, 3/8" BSP	
⑦	001167	1	Hose, 3/8" x 1200, 3/8" BSP straight ends, from HP oil filter to Port P	
⑧	001226	1	Hose, 3/8" x 530, 3/8" BSP straight and 90° ends, from Port T to oil tank	
⑨	043400	1	Pipe, steel, from low pressure water pump to Port OC2	
⑩	043399	1	Pipe, steel, from Port OC1 to low pressure water pump	
⑪	043402	1	Pipe, steel, from high pressure water pump to Port OB2	
⑫	043401	1	Pipe, steel, from Port OB1 to high pressure water pump	
⑬	020903	4	Adapter ø12 x 3/8" BSP	
⑭	001220	1	Hose, 3/8" x 410, 3/8" BSP straight and 90° ends, from low pressure water pump	
⑮	001220	1	Hose, 3/8" x 410, 3/8" BSP straight and 90° ends, to low pressure water pump	
⑯	001149	1	Hose, 3/8" x 3550, 3/8" BSP straight and 90° ends, from high pressure water pump	
⑰	001149	1	Hose, 3/8" x 3550, 3/8" BSP straight and 90° ends, to high pressure water pump	
⑱	002236 *	As req	Blanking plug 12mm	
⑱	002130 *	As req	Compression nut	

\*. These items are used to blank any ports not being used by attaching to the associated adapter.

Hopper control valve, coils and solenoids

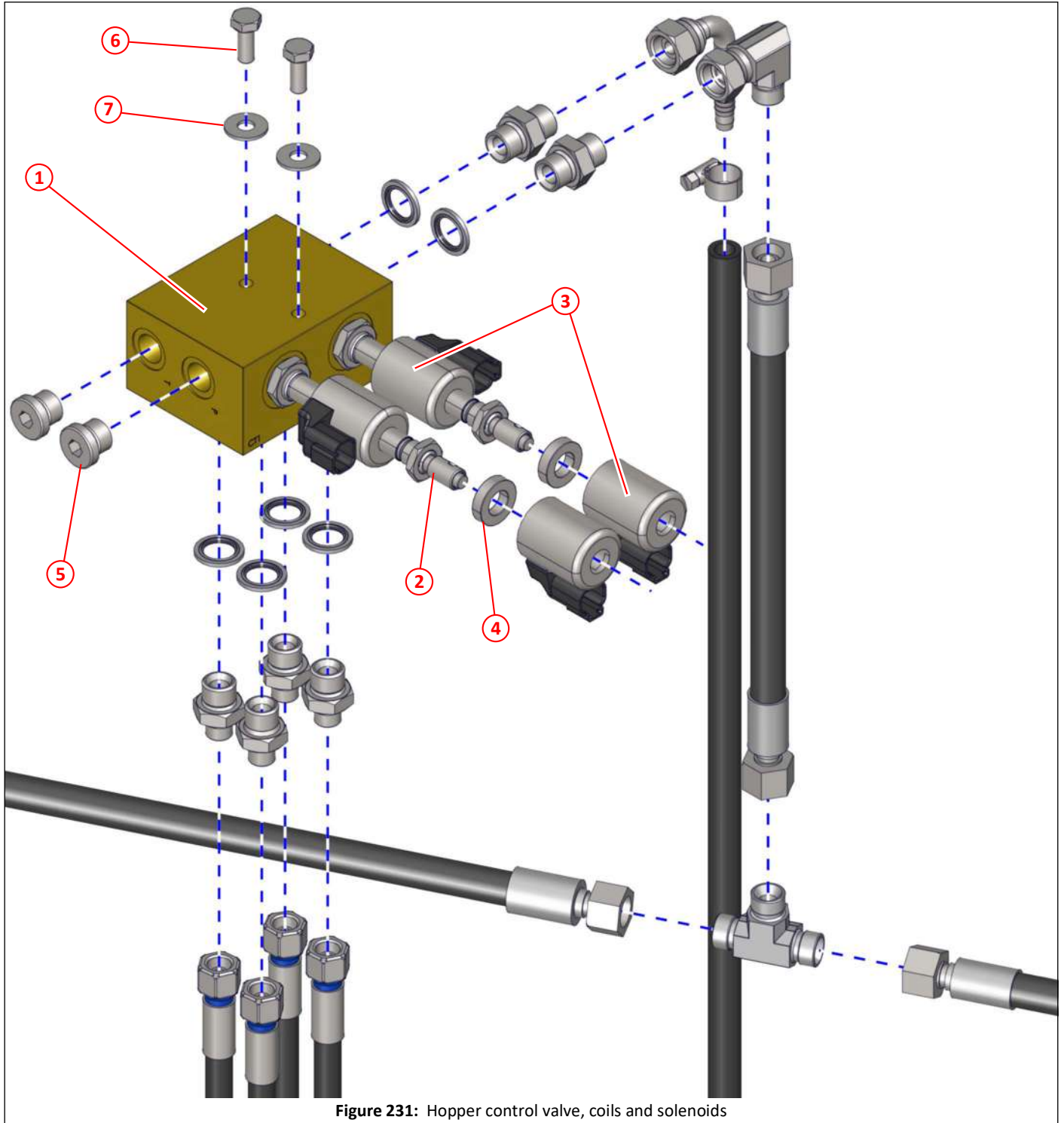

Figure 231: Hopper control valve, coils and solenoids

Item	Part No	Qty	Description
①	039703	1	Hopper control valve, includes items ②, ③ and ④, 24v
①	044491	1	Hopper control valve, includes items ②, ③ and ④, 12v
②	039746	2	Solenoid valve
③	039747	4	Coil with diode, 24V
③	041225	4	Coil with diode, 12v
④	039748	2	Coil spacer
⑤	035242	2	Port plug $\frac{3}{8}$ " BSP
⑥	011010	2	Set screw M8 x 20
⑦	011092	2	Plain washer M8



Hopper control valve, fittings and hoses

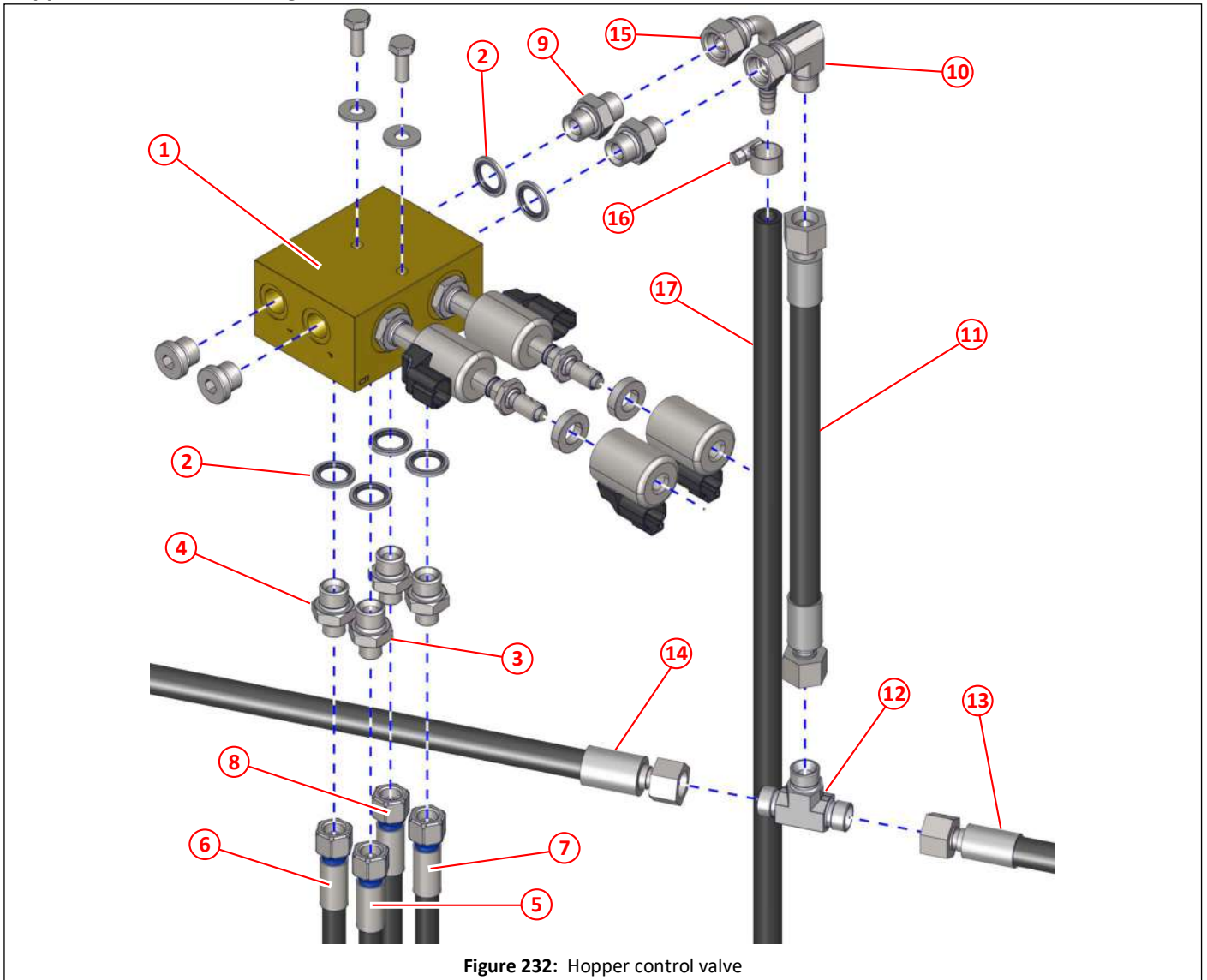

Figure 232: Hopper control valve

Item	Part No	Qty	Description	
①	039703	1	Hopper control valve, 24v	268
①	044491	1	Hopper control valve, 12v	268
②	011153	6	Dowty seal $\frac{3}{8}$ " BSP	
③	040217	1	Adapter, M/M, $\frac{1}{4}$ " BSP x $\frac{3}{8}$ " BSP $\frac{3}{64}$ " restrictor orange	
④	011199	3	Adapter, M/M, $\frac{3}{8}$ " BSP x $\frac{1}{4}$ " BSP	
⑤	001036	1	Hose, $\frac{1}{4}$ " x 4100, $\frac{1}{4}$ " BSP straight ends, Port B to hopper door ram open	
⑥	010036	1	Hose, $\frac{1}{4}$ " x 4100, $\frac{1}{4}$ " BSP straight ends, Port A to hopper door ram close	
⑦	001264	1	Hose, $\frac{1}{4}$ " x 1000, $\frac{1}{4}$ " BSP straight ends, Port D to hopper lift ram raise	
⑧	011329	1	Hose, $\frac{1}{4}$ " x 1200, $\frac{1}{4}$ " BSP straight ends, Port C to hopper lift ram lower	
⑨	011159	2	Adapter, M/M, $\frac{3}{8}$ " BSP	
⑩	011172	1	Elbow, swivel, M/F, $\frac{3}{8}$ " BSP	
⑪	011310	1	Hose $\frac{3}{8}$ " x 300, $\frac{3}{8}$ " BSP straight ends, Port P to hand pump/main valve block Port HL	
⑫	011198	1	Tee, M/M/M, $\frac{3}{8}$ " BSP	
⑬	011311	1	Hose $\frac{3}{8}$ " x 1100, $\frac{3}{8}$ " BSP straight ends, from main valve block Port HL	
⑭	001017	1	Hose $\frac{3}{8}$ " x 1000, $\frac{3}{8}$ " BSP straight ends, to hand pump	
⑮	002048	1	Elbow, swept, $\frac{3}{8}$ " BSP x $\frac{3}{8}$ " BSP hose tail, Port T to return to tank	
⑯	010516	1	Hose clamp, worm drive, No. M00 ( $\phi$ 11mm- $\phi$ 16mm)	
⑰	010958	As req	Hose $\frac{3}{8}$ ", return to tank	

Hand pump, hopper and rear door

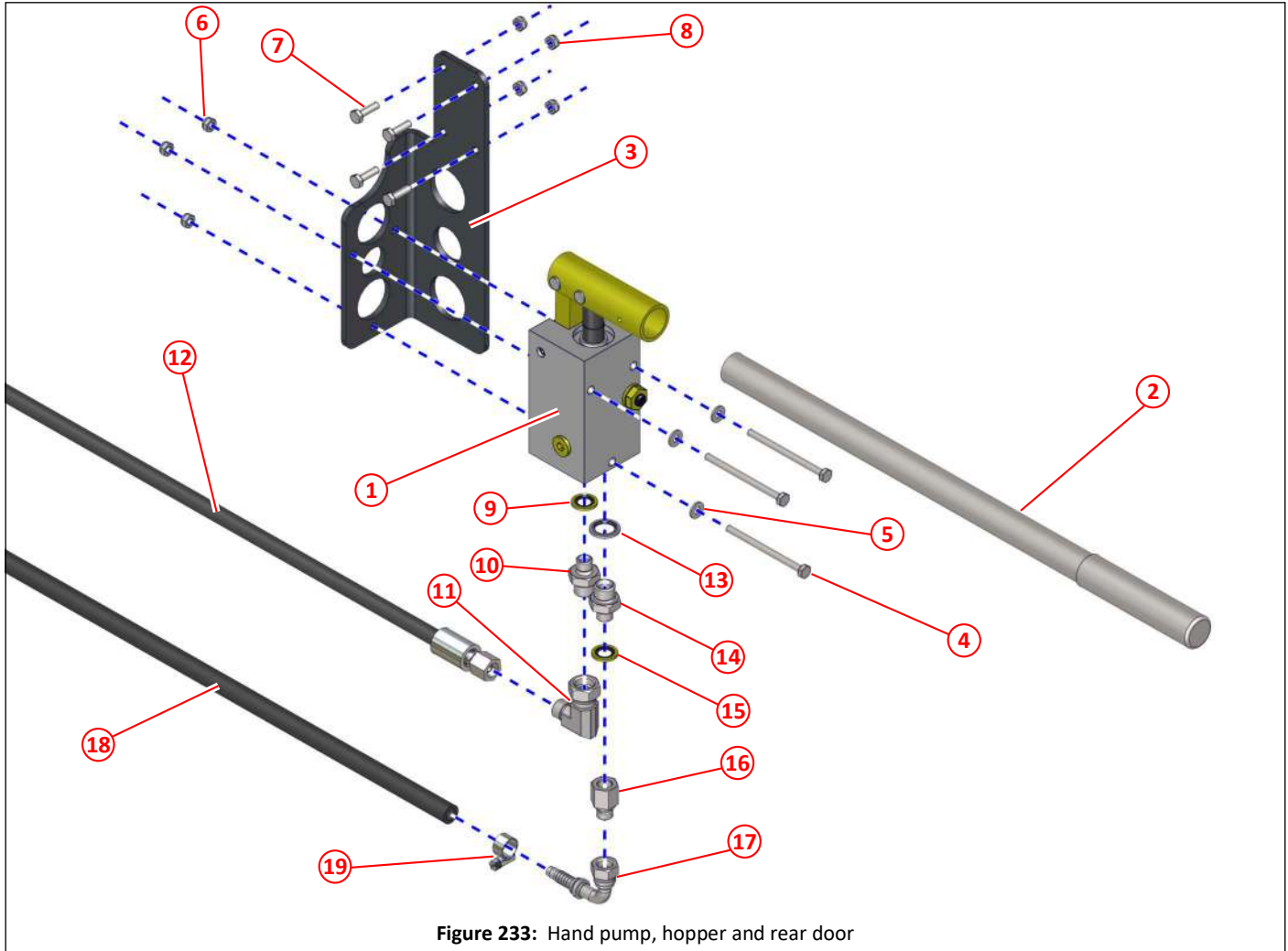

Figure 233: Hand pump, hopper and rear door

Item	Part No	Qty	Description
①	023006	1	Hand pump, hydraulic, hopper and rear door
②	038657	1	Handle, hand pump
③	038257	1	Bracket, hand pump
④	000221	3	Bolt M6 x 80
⑤	011090		Plain washer M6
⑥	011071	3	Nyloc nut M6
⑦	011067	4	Set screw M6 x 20
⑧	011071	4	Nyloc nut M6
⑨	011152	1	Dowty seal $\frac{1}{4}$ " BSP
⑩	011199	1	Adapter, M/M, $\frac{3}{8}$ " BSP x $\frac{1}{4}$ " BSP
⑪	011172	1	Elbow, swivel, M/F, $\frac{3}{8}$ " BSP
⑫	001017	1	Hose $\frac{3}{8}$ " x 1000, $\frac{3}{8}$ " BSP straight ends, to hand pump Port P from hopper control valve
⑬	011153	1	Dowty seal $\frac{3}{8}$ " BSP
⑭	011199	1	Adapter, M/M, $\frac{3}{8}$ " BSP x $\frac{1}{4}$ " BSP
⑮	011152	2	Dowty seal $\frac{1}{4}$ " BSP
⑯	002014	1	Adapter, M/F, fixed, $\frac{1}{4}$ " BSP
⑰	002237	1	Adapter, $\frac{1}{4}$ " BSP x $\frac{3}{8}$ " hose tail, 90°
⑱	010958	As req	Hose $\frac{3}{8}$ ", from hand pump Port T to hydraulic tank return
⑲	010516	1	Hose clamp, worm drive, No. M00 (ø11mm-ø16mm)



Ram, dual stage, hopper lift

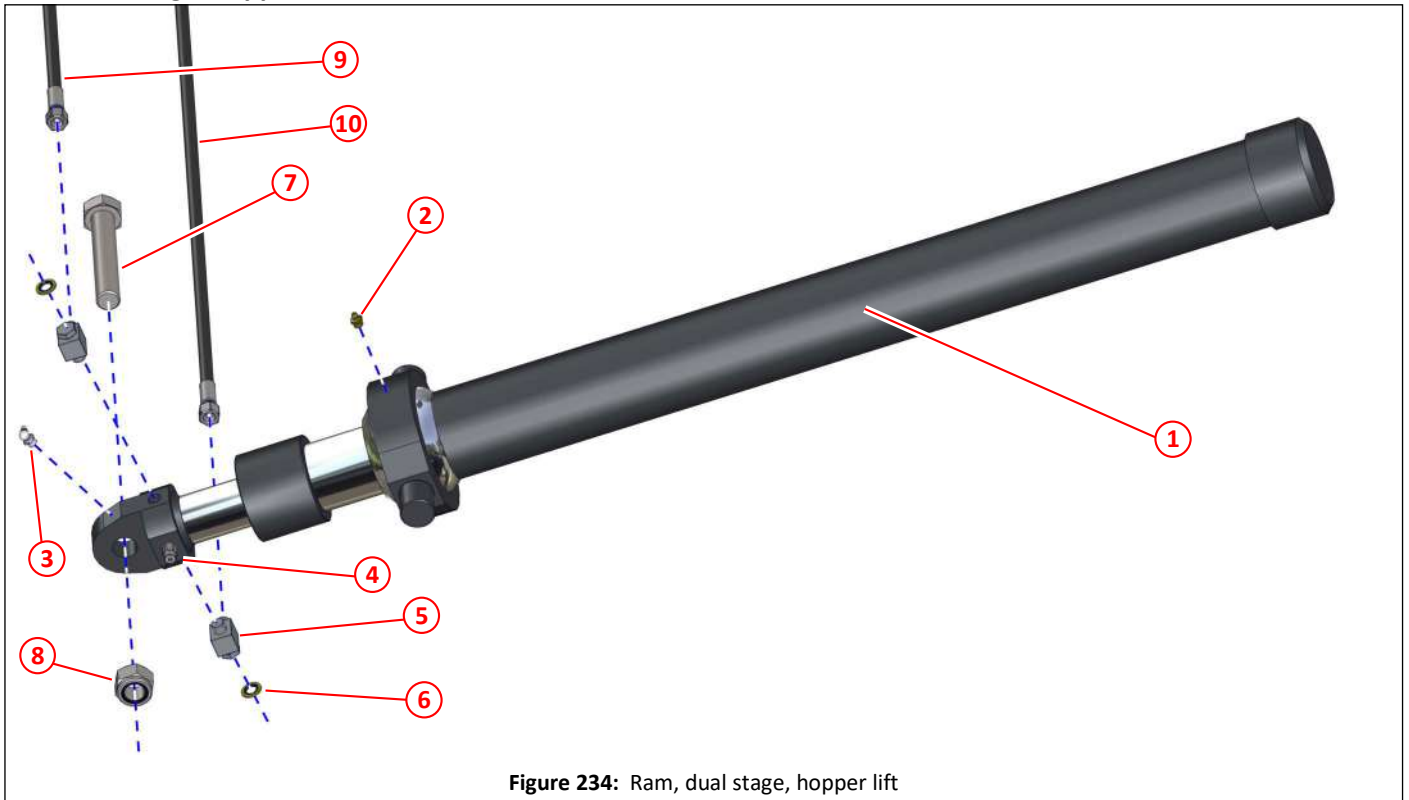

Figure 234: Ram, dual stage, hopper lift

Item	Part No	Qty	Description	
①	024249	1	Ram, dual acting, hopper lift	155
②	010903	1	Grease nipple $\frac{1}{8}$ " BSP straight	
③	010902	1	Grease nipple $\frac{1}{8}$ " BSP x 90°	
④	028178	2	Check valve 1CE 30F35S5	
⑤	002017	2	Banjo adapter $\frac{1}{4}$ " BSP	
⑥	011152	2	Dowty seal $\frac{1}{4}$ " BSP	
⑦	000241	1	Bolt M24 x 130	
⑧	000008	1	Nyloc nut M24	
⑨	001264	1	Hose, $\frac{1}{4}$ " x 1000, $\frac{1}{4}$ " BSP straight ends, from hopper control valve Port D to ram raise	
⑩	011329	1	Hose, $\frac{1}{4}$ " x 1200, $\frac{1}{4}$ " BSP straight ends, from hopper control valve Port C to ram lower	
NI	027885	1	Seal kit, ram	

Ram, rear door open/close/locking

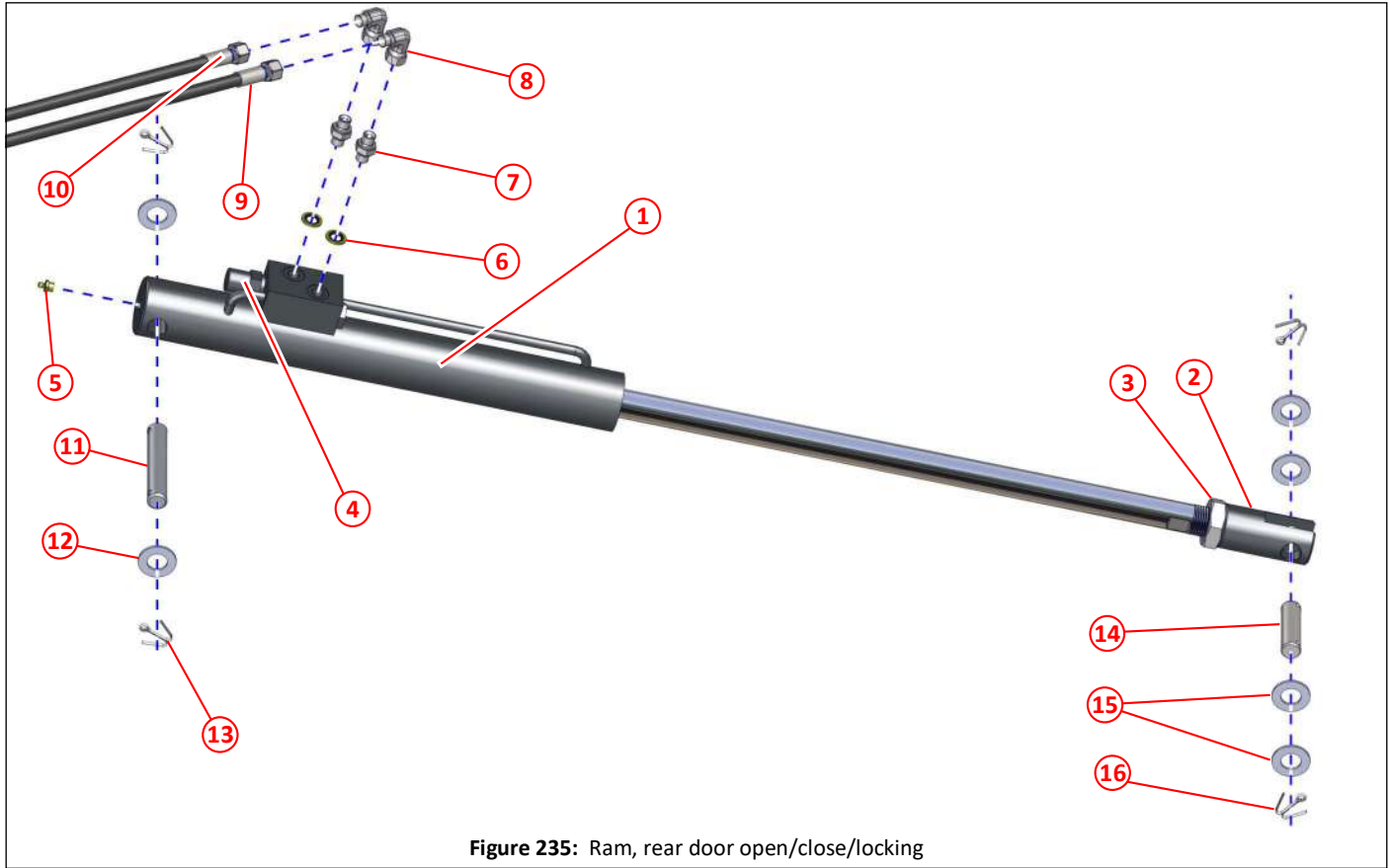

Figure 235: Ram, rear door open/close/locking

Item	Part No	Qty	Description	
①	034816	1	Door ram, open/close/locking, includes items ②, ③ and ④	189
②	042284	1	Clevis, door ram	
③	042285	1	Nut, clevis, door ram	
④	028178	1	Check valve 1CE 30F35S5	
⑤	010903	1	Grease nipple 1/8" BSP straight	
⑥	011152	2	Dowty seal 1/4" BSP	
⑦	011158	2	Adapter, M/M, 1/4" BSP x 1/4" BSP	
⑧	011171	2	Elbow, swivel, M/F, 1/4" BSP	
⑨	001321	1	Hose, 1/4" BSP x 1850, straight ends,	
⑩	011328	1	Hose, 1/4" BSP x 1780, straight ends,	
⑪	022558	1	Pin, rear door ram	
⑫	011102	2	Plain washer M20	
⑬	011122	2	Split pin 3/16" x 1 1/2"	
⑭	014038	1	Pin ø20 x 70	
⑮	011102	4	Plain washer M20	
⑯	011122	2	Split pin 3/16" x 1 1/2"	

Ram, side brush lift

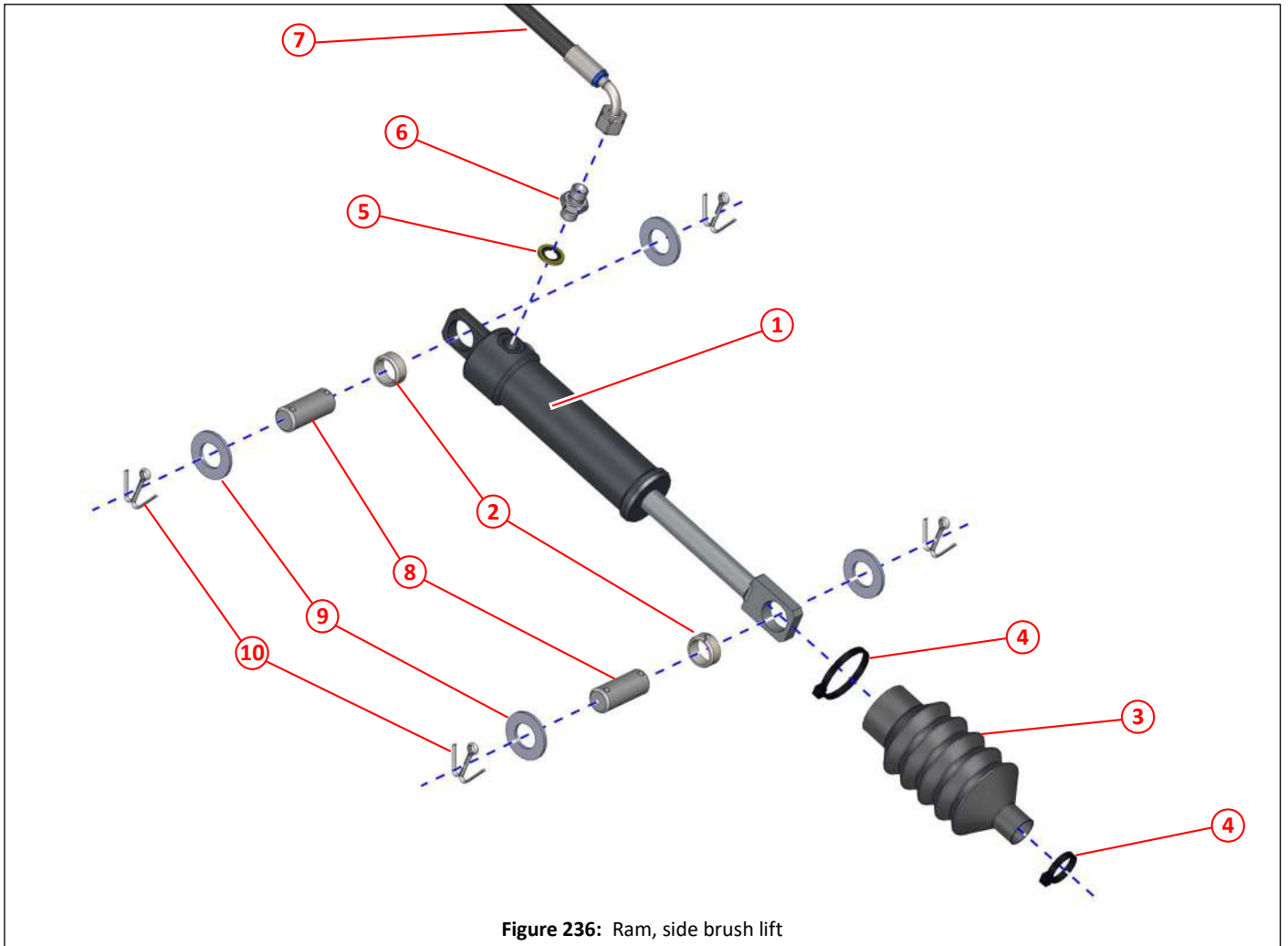

Figure 236: Ram, side brush lift

Item	Part No	Qty	Description	
①	010009	1	Ram, No. 12 240/340, side brush lift	33,42
②	024682	2	Bush $\varnothing 20 \times \varnothing 25 \times 10$	
③	014473	1	Bellows, ram	
④	005018	2	Cable tie	
⑤	011152	1	Dowty seal $\frac{1}{4}$ " BSP	
⑥	012539	1	Adapter, restrictor No. 5 $\frac{1}{32}$ " white, M/M, $\frac{1}{4}$ " BSP x $\frac{1}{4}$ " BSP	
⑦	001101	1	Hose, $\frac{1}{4}$ " BSP x 1125, straight and 90° ends	
⑧	010067	2	Pin $\varnothing 20 \times 50$	
⑨	011102	4	Plain washer M20	
⑩	011122	4	Split pin $\frac{3}{16}$ " x $1\frac{1}{2}$ "	

	024539	1	Ram, side brush lift assembly, includes items ①, ②, ③, ④, ⑤ and ⑥	
--	--------	---	---	--

Ram, suction nozzle tilt

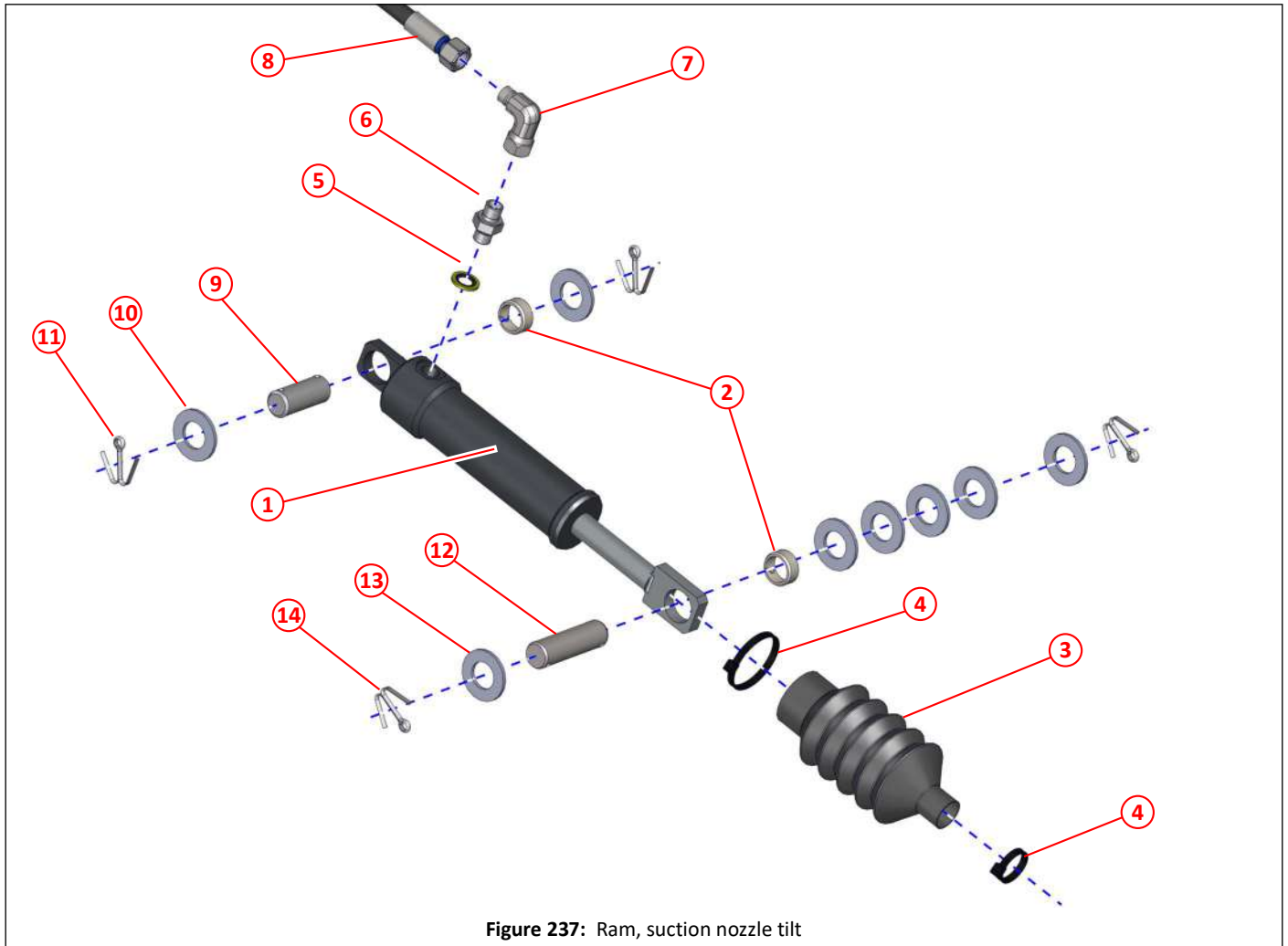

Figure 237: Ram, suction nozzle tilt

Item	Part No	Qty	Description	
①	041954	1	Ram, No. 12 240/340, suction nozzle tilt	87,104
②	024682	2	Bush $\varnothing 20 \times \varnothing 25 \times 10$	
③	014473	1	Bellows, ram	
④	005018	2	Cable tie	
⑤	011152	1	Dowty seal $\frac{1}{4}$ " BSP	
⑥	027188	1	Adapter, restrictor 0.6, M/M, $\frac{1}{4}$ " BSP	
⑦	011171	1	Elbow, swivel, M/F, $\frac{1}{4}$ " BSP	
⑧	001027	1	Hose, $\frac{1}{4}$ " BSP x 1270, straight ends	
⑨	010067	1	Pin $\varnothing 20 \times 50$	
⑩	011102	2	Plain washer M20	
⑪	011122	2	Split pin $\frac{3}{16}$ " x $1\frac{1}{2}$ "	
⑫	014038	1	Pin $\varnothing 20 \times 70$	
⑬	011102	6	Plain washer M20	
⑭	011122	2	Split pin $\frac{3}{16}$ " x $1\frac{1}{2}$ "	
	041955	1	Ram, suction nozzle assembly, includes items ①, ②, ③, ④, ⑤ and ⑥	

Motor, side brush

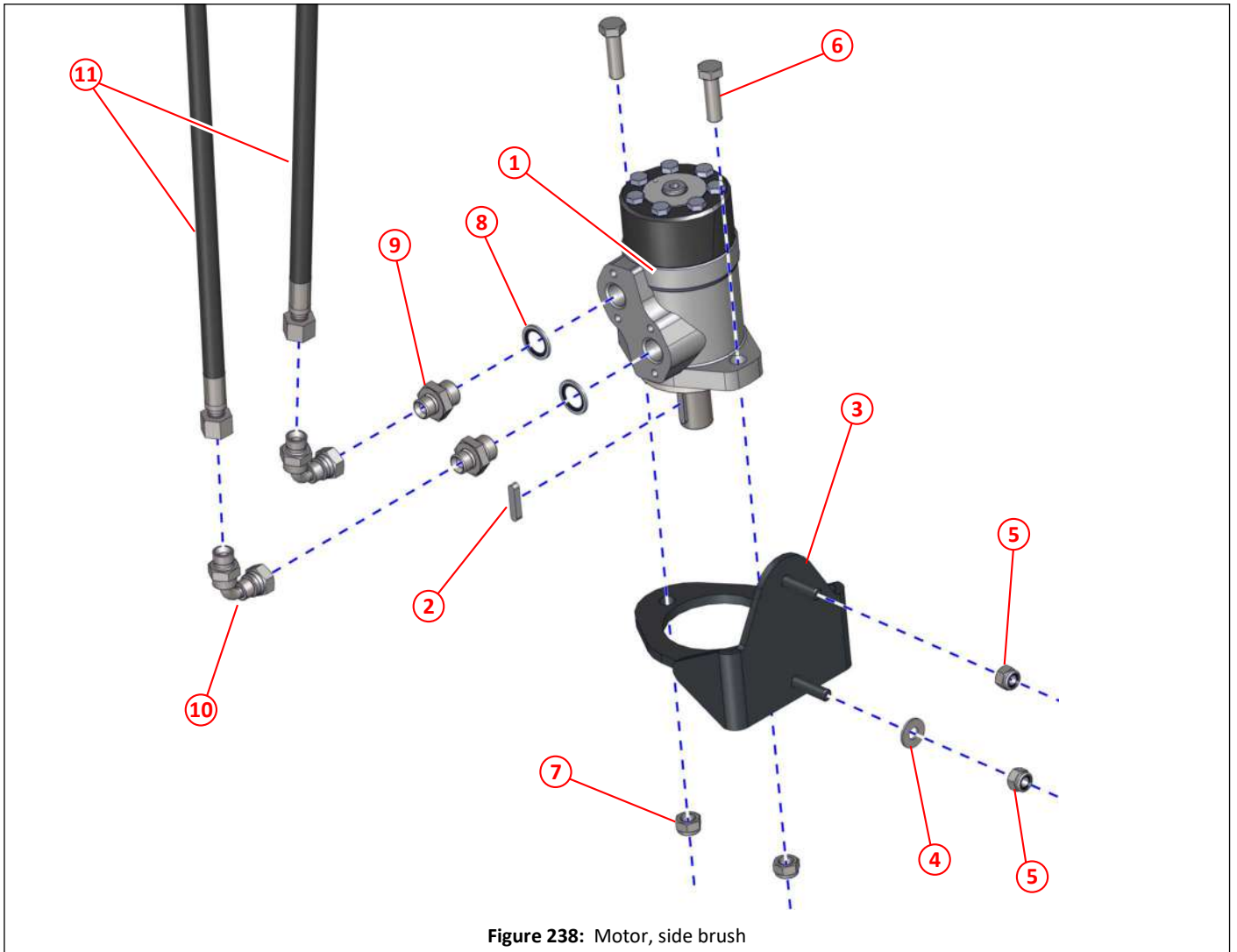

Figure 238: Motor, side brush

Item	Part No	Qty	Description	
①	010749	1	Motor, 3597 (OMP 200), side brush	44
②	011515	1	Key for motor	
③	010007	1	Bracket, motor	
④	011094	1	Plain washer M10	
⑤	011075	2	Nyloc nut M10	
⑥	011069	2	Bolt M12 x 40	
⑦	011077	2	Nyloc nut M12	
⑧	011154	2	Dowty seal $\frac{1}{2}$ " BSP	
⑨	011167	2	Adapter, M/M, $\frac{1}{2}$ " BSP x $\frac{3}{8}$ " BSP	
⑩	011221	2	Elbow, swept, M/F, $\frac{3}{8}$ " BSP	
⑪	011307	2	Hose, $\frac{3}{8}$ " BSP x 1300, straight ends	

Motor, central brush (wide sweep)

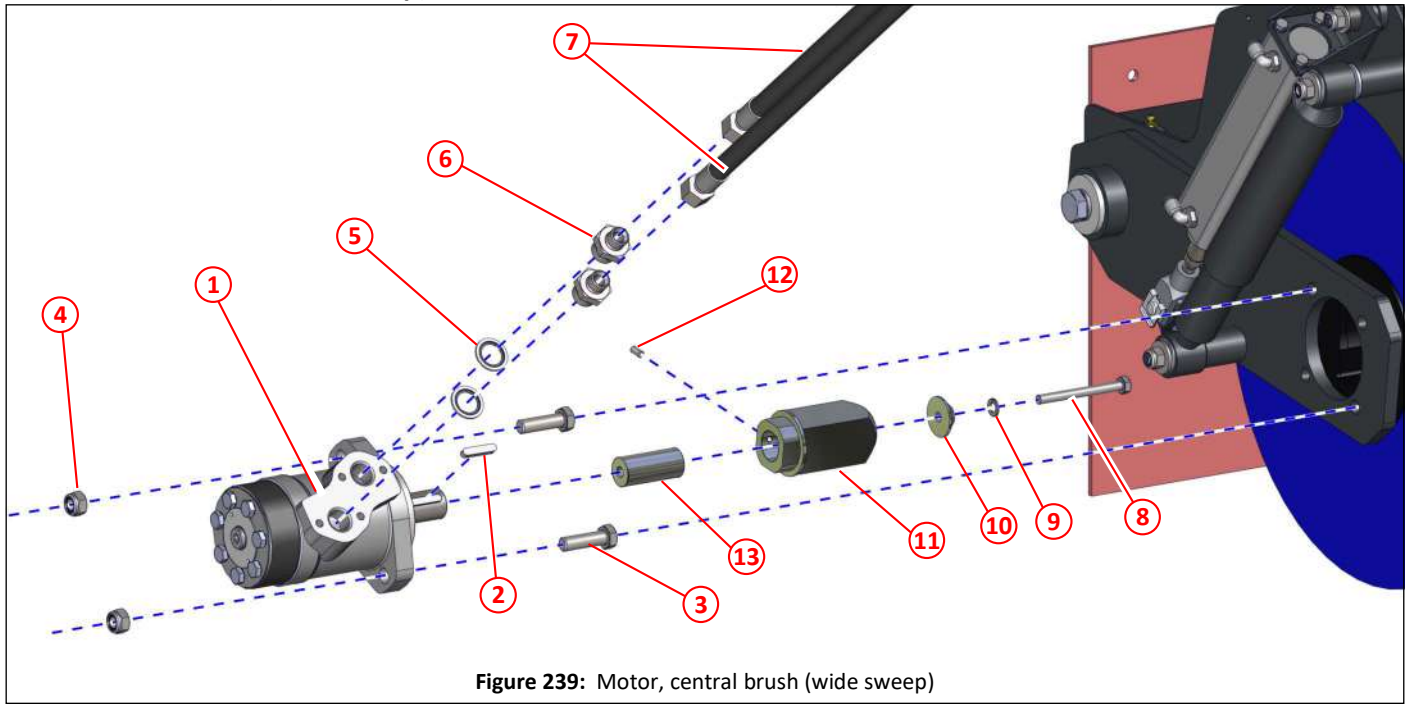

Figure 239: Motor, central brush (wide sweep)

Item	Part No	Qty	Description	
①	010566	1	Motor 3596 (OMP 100), central brush (wide sweep)	53, 62
②	011515	1	Key for motor	
③	011069	2	Bolt M12 x 40	
④	011077	2	Nyloc nut M12	
⑤	011154	2	Dowty seal 1/2" BSP	
⑥	011167	2	Adapter, M/M, 1/2" x 3/8" BSP	
⑦	001167	2	Hose, 3/8" BSP x 1200, straight ends	
⑧	011415	1	Bolt M8 x 80	
⑨	011093	1	Spring washer M8	
⑩	024538	1	Washer cone	
⑪	024535	1	Drive shaft, central brush (wide sweep)	
⑫	011112	1	Socket set screw M6 x 12	
⑬	038106	1	Spacer ø8.5 x ø25 x 55	



Motor, suction fan

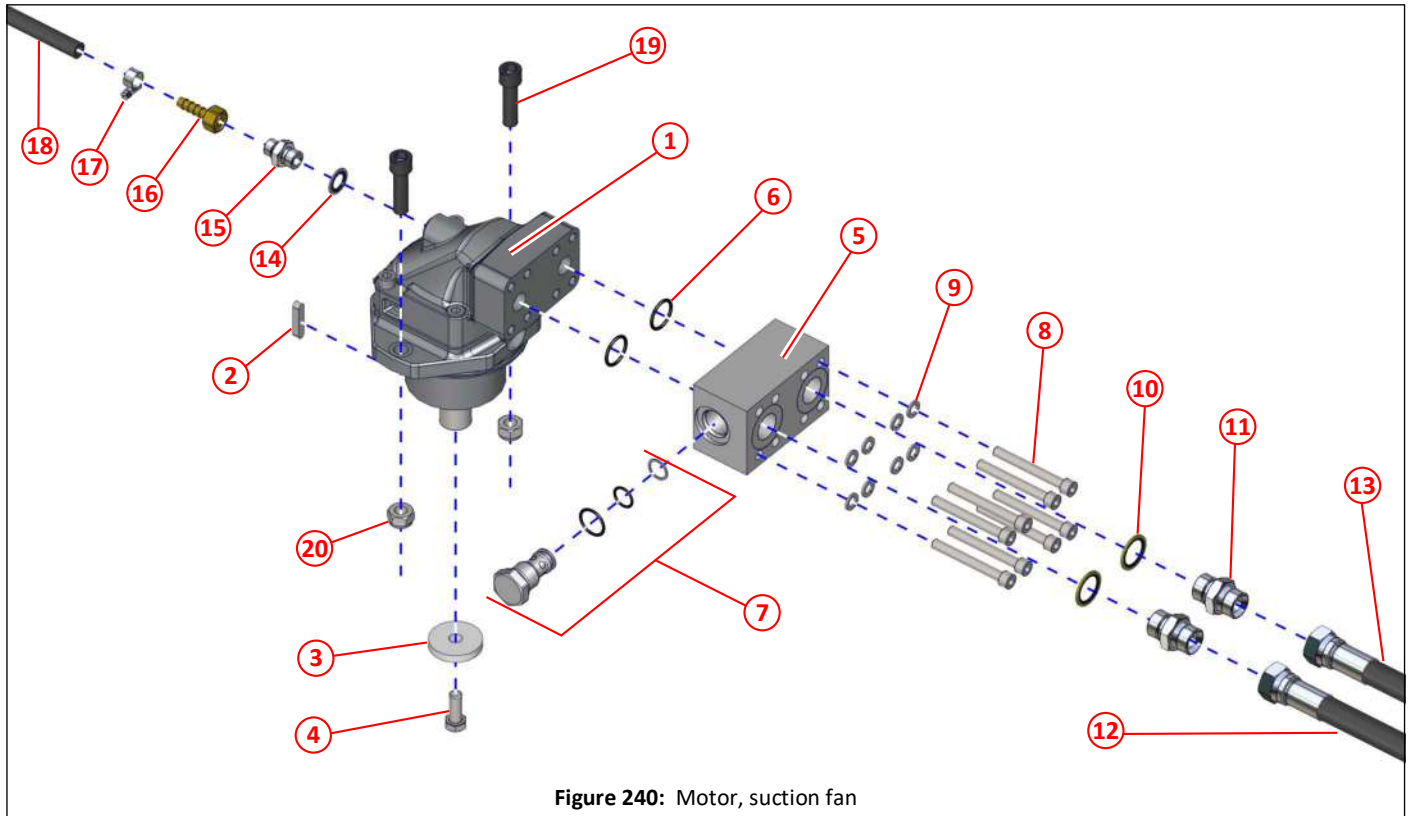

Figure 240: Motor, suction fan

Item	Part No	Qty	Description	
①	024641	1	Motor, suction fan	261
②	013292	1	Key for item ①	
③	044926	1	Washer $\phi 12.5 \times \phi 50 \times 8$ , stainless steel	
④	011052	1	Set screw M12 x 30	
⑤	041633*	1	Manifold, anti-cavitation valve	
⑥	041634*	2	'O' ring	
⑦	041635*	1	Check valve, includes seals and washer	
⑧	000048	8	Socket cap head screw M10 x 80	
⑨	011095	8	Spring washer M10	
⑩	011155	2	Dowty seal $\frac{3}{4}$ " BSP	
⑪	011161	2	Adapter $\frac{3}{4}$ " BSP	
⑫	001322	1	Hose $\frac{5}{8}$ " x 1550, $\frac{3}{4}$ " BSP straight ends	
⑬	001333	1	Hose $\frac{5}{8}$ " x 1700, $\frac{3}{4}$ " BSP straight ends	
⑭	011247	1	Dowty seal M18	
⑮	011248	1	Adapter M18 x $\frac{3}{8}$ " BSP	
⑯	010921	1	Adapter $\frac{3}{8}$ " BSP x $\frac{3}{8}$ " hose tail, complete with but	
⑰	010516	1	Hose clamp, worm drive No. MOO ( $\phi 11\text{mm}-\phi 16\text{mm}$ )	
⑱	010958	As req	Hose $\frac{3}{8}$ "	
⑲	000343	2	Socket cap head bolt M14 x 50, black	
⑳	011127	2	Nyloc nut M14	

*	041564	1	Anti-cavitation valve assembly, includes items ⑤, ⑥ and ⑦	
---	--------	---	---	--

Motor, low pressure water pump

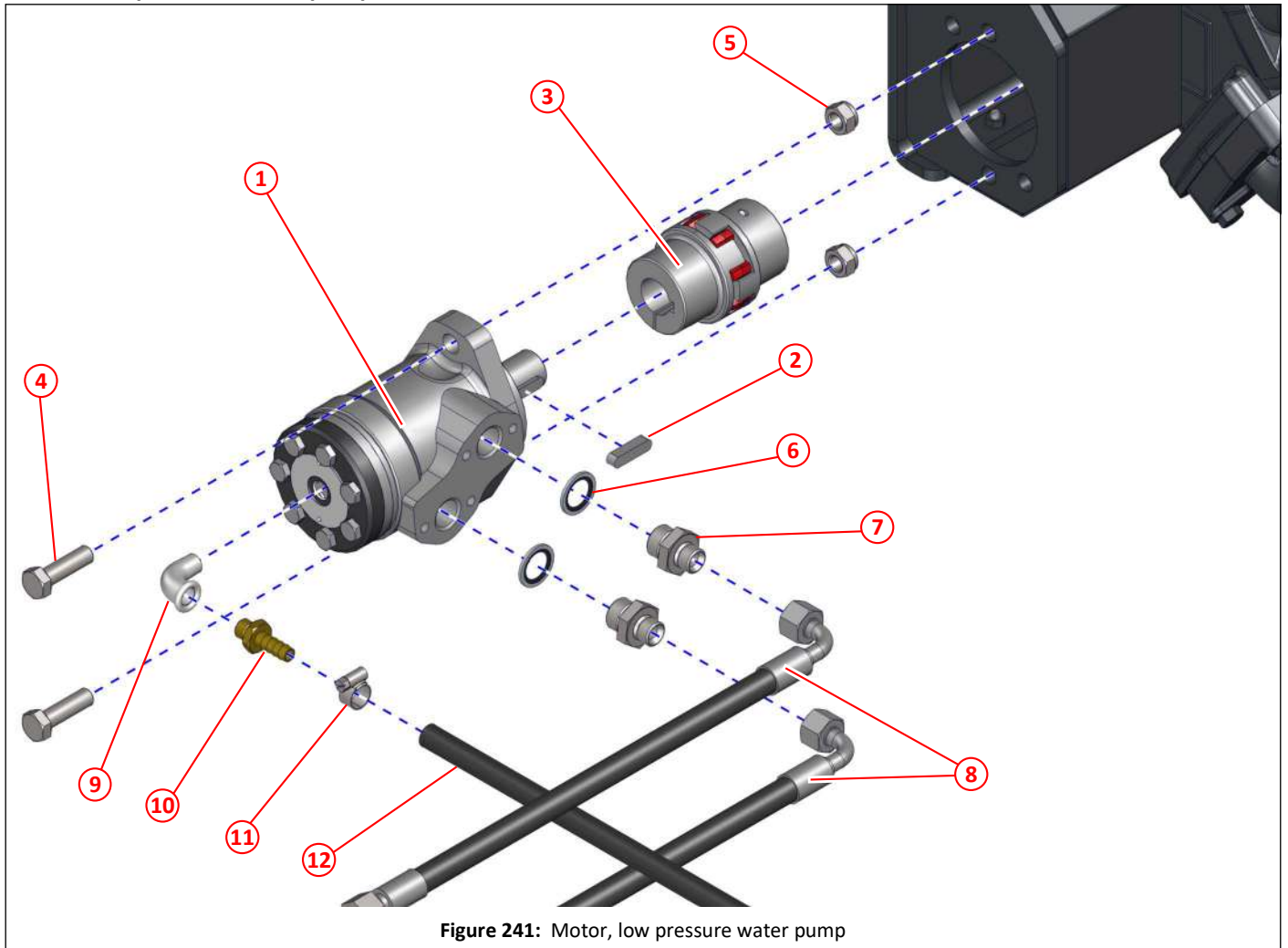

Figure 241: Motor, low pressure water pump

Item	Part No	Qty	Description	
①	043778	1	Motor, 40cc, low pressure water pump	215
②	011515	1	Key for motor	
③	043779	1	Coupling, water pump	
④	011069	2	Bolt M12 x 40	
⑤	011077	2	Nyloc nut M12	
⑥	011154	2	Dowty seal 1/2" BSP	
⑦	011167	2	Adapter, M/M, 1/2" BSP x 3/8" BSP	
⑧	001220	2	Hose, 3/8" x 410, 3/8" BSP straight and 90° ends, to/from options block Ports OC1 and OC2	
⑨	010910	1	Elbow, M/F, 1/4" BSP	
⑩	010922	1	Adapter 1/4" BSP x 3/8" hose tail	
⑪	010516	1	Hose clamp, worm drive, No M00 (ø11-ø16)	
⑫	010950	As req	Hose ø9.5 ID, black braided PVC, drain to oil tank	

Motor, high pressure water pump

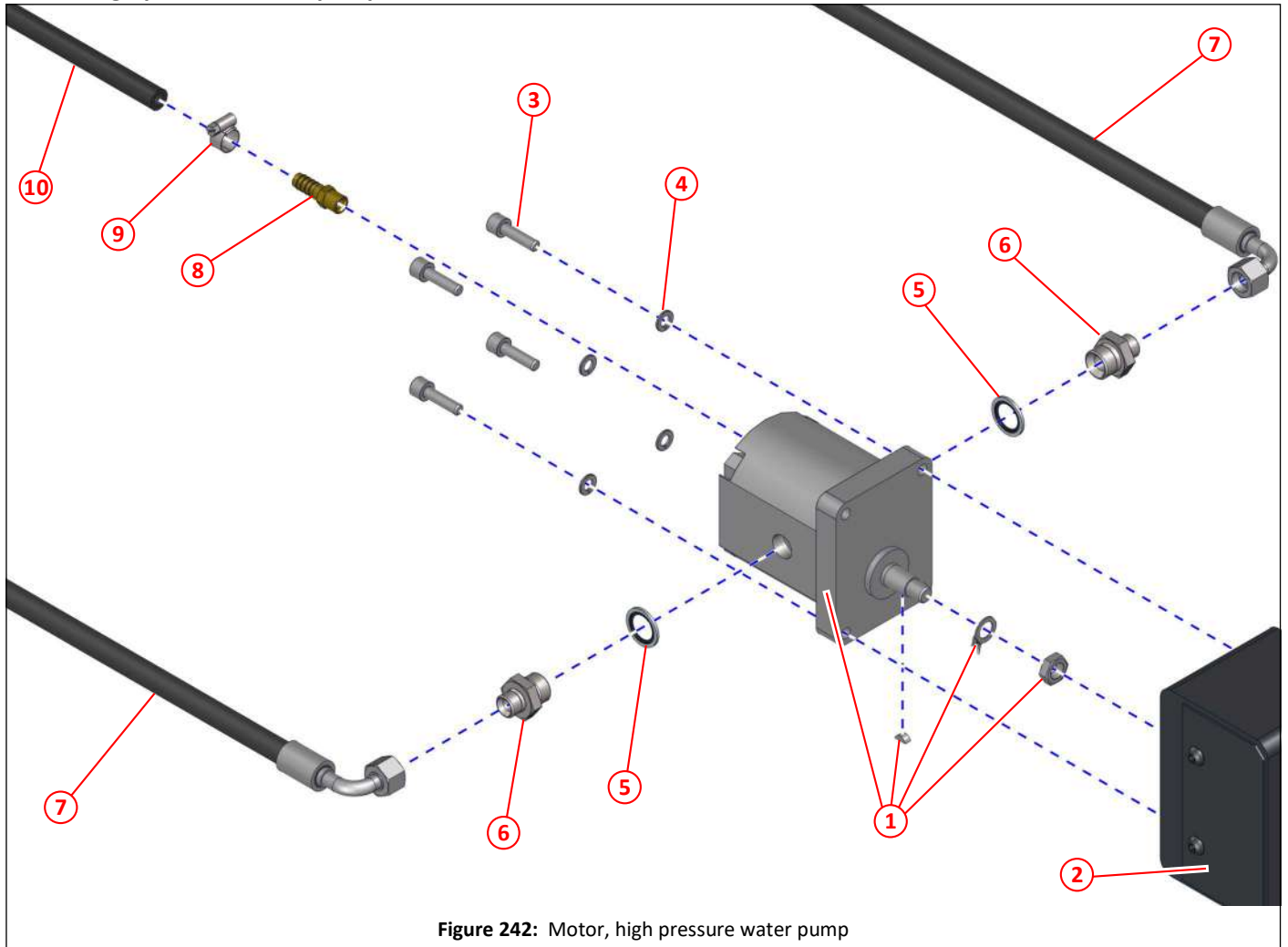

Figure 242: Motor, high pressure water pump

Item	Part No	Qty	Description	
①	025373	1	Motor, hydraulic, 19cc	232
②	036554	1	Drive box kit 30lpm pump	
③	000017	4	Socket cap head screw, M8 x 30	
④	011093	4	Spring washer M8	
⑤	011154	2	Dowty seal 1/2" BSP	
⑥	011167	2	Adapter, M/M, 1/2" BSP x 3/8" BSP	
⑦	001149	2	Hose, 3/8" x 3550, 3/8" BSP straight and 90° ends, to/from options block Ports OB1 and OB2	
⑧	003010	1	Adapter 1/4" BSPT x 3/8" hose tail	
⑨	010516	1	Hose clamp, worm drive, No M00 (ø11-ø16)	
⑩	010950	As req	Hose ø9.5 ID, black braided PVC, drain to oil tank	

## Hoses

Part No	Description	
001017	Hose $\frac{3}{8}$ " x 1000, $\frac{3}{8}$ " BSP straight ends	269, 270
001027	Hose, $\frac{1}{4}$ " BSP x 1270, straight ends	274
001036	Hose, $\frac{1}{4}$ " x 4100, $\frac{1}{4}$ " BSP straight ends	269
001037	Hose, $\frac{1}{4}$ " x 2650, $\frac{1}{2}$ " BSP straight and 90° ends	255
001075	Hose, $\frac{1}{2}$ " x 500, $\frac{1}{2}$ " BSP straight and 90° ends	259
001101	Hose, $\frac{1}{4}$ " BSP x 1125, straight and 90° ends	273
001149	Hose, $\frac{3}{8}$ " x 3550, $\frac{3}{8}$ " BSP straight and 90° ends	267, 279
001151	Hose, $\frac{1}{4}$ " x 3040, $\frac{1}{4}$ " BSP straight and 90° ends with 6mm elbow	257, 260
001167	Hose, $\frac{3}{8}$ " x 1200, $\frac{3}{8}$ " BSP straight ends	256, 266, 267, 276
001220	Hose, $\frac{3}{8}$ " x 410, $\frac{3}{8}$ " BSP straight and 90° ends	267, 278
001226	Hose, $\frac{3}{8}$ " x 530, $\frac{3}{8}$ " BSP straight and 90° ends	266, 267
001238	Hose, $\frac{5}{8}$ " x 420, $\frac{3}{4}$ " BSP straight and 90° ends	258
001261	Hose, $\frac{1}{2}$ " BSP x 350, 90°/90° 270° rotation	257, 254, 255
001264	Hose, $\frac{1}{4}$ " x 1000, $\frac{1}{4}$ " BSP straight ends	269, 271
001271	Hose, $\frac{1}{2}$ " BSP x 960, straight and 90° ends	248, 265
001306	Hose $\frac{5}{8}$ " x 1530, $\frac{5}{8}$ " BSP straight and 90° ends	257, 258
001308	Hose, $\frac{1}{2}$ " BSP x 2200, straight ends	248
001310	Hose, $\frac{5}{8}$ " x 1630, $\frac{3}{4}$ " BSP straight ends	253, 257, 258
001311	Hose, $\frac{5}{8}$ " x 5700, $\frac{3}{4}$ " BSP straight ends	253
001321	Hose, $\frac{1}{4}$ " BSP x 1850, straight ends	272
001322	Hose, $\frac{5}{8}$ " x 1550, $\frac{3}{4}$ " BSP straight ends	261, 277
001327	Hose, $\frac{3}{8}$ " x 310, 90° ends, 180° rotation	255, 256
001328	Hose, $\frac{1}{2}$ " BSP x 810, straight and 90° ends	248, 265
001333	Hose, $\frac{5}{8}$ " x 1700, $\frac{3}{4}$ " BSP straight ends	261, 277
002092	Hose, $\frac{3}{8}$ " x 340, $\frac{3}{8}$ " BSP straight and 90° ends	255, 256
010036	Hose, $\frac{1}{4}$ " x 4100, $\frac{1}{4}$ " BSP straight ends	269
010958	Hose, $\frac{3}{8}$ "	257, 260, 261, 269, 270, 277
010990	Hose, $\frac{1}{4}$ " x 600, $\frac{1}{4}$ " BSP straight ends	258, 260
011306	Hose, $\frac{3}{8}$ " x 1400, $\frac{3}{8}$ " BSP straight ends	256, 265
011307	Hose, $\frac{3}{8}$ " x 1300, $\frac{3}{8}$ " BSP straight ends	275
011310	Hose $\frac{3}{8}$ " x 300, $\frac{3}{8}$ " BSP straight ends	269
011311	Hose, $\frac{3}{8}$ " x 1100, $\frac{3}{8}$ " BSP straight ends	265, 269
011328	Hose, $\frac{1}{4}$ " BSP x 1780, straight ends	272
011329	Hose, $\frac{1}{4}$ " x 1200, $\frac{1}{4}$ " BSP straight ends	269, 271
031272	Hose, 2" x 300	250, 251
042893	Intercooler hose 'A'	248
042894	Intercooler hose 'B'	248
042895	Coolant hose 'A'	248
042896	Coolant hose 'B'	248
043769	Hose	251, 252, 253
043770	Hose	251, 252, 254
043771	Hose	251, 252, 254

Steel pipes, brushes, left hand sweep

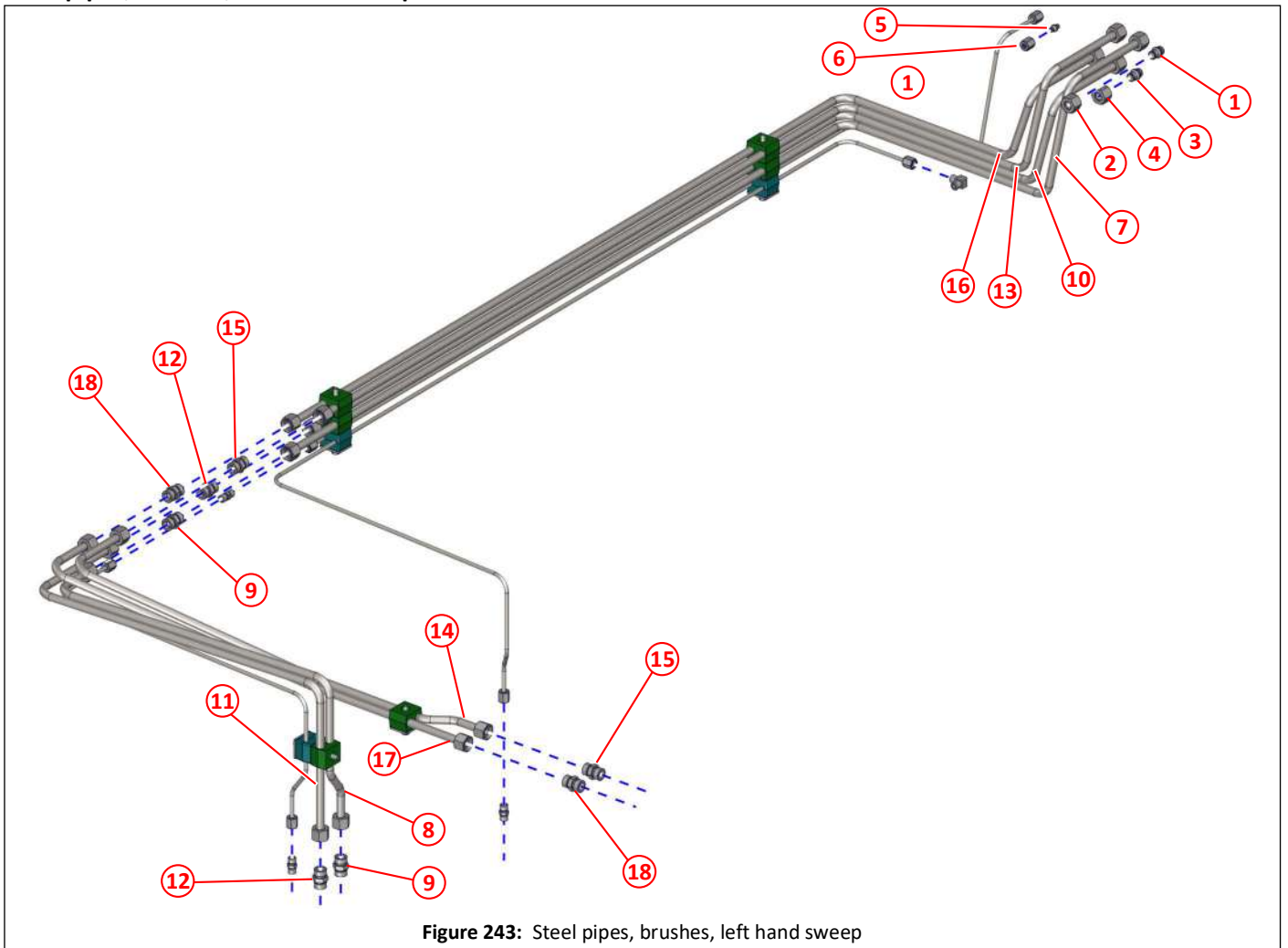

Figure 243: Steel pipes, brushes, left hand sweep

Item	Part No	Qty	Description
①	002236	1	Blanking plug 12mm
②	002130	1	Compression nut 12mm
③	002236	1	Blanking plug 12mm
④	002130	1	Compression nut 12mm
⑤	002235	1	Blanking plug 6mm
⑥	002132	1	Compression nut 6mm
⑦	043405	1	Pipe, steel, feed, left hand side brush, part 1
⑧	043406	1	Pipe, steel, feed, left hand side brush, part 2
⑨	002088	2	Union tube/tube 12mm x 12mm, body only
⑩	043407	1	Pipe, steel, return, left hand side brush, part 1
⑪	043408	1	Pipe, steel, return, left hand side brush, part 2
⑫	002088	2	Union tube/tube 12mm x 12mm, body only
⑬	043416	1	Pipe, steel, feed, central brush (wide sweep), part 1
⑭	043417	1	Pipe, steel, feed, central brush (wide sweep), part 2
⑮	002088	2	Union tube/tube 12mm x 12mm, body only
⑯	043418	1	Pipe, steel, return, central brush (wide sweep), part 1
⑰	043419	1	Pipe, steel, return, central brush (wide sweep), part 2
⑱	002088	2	Union tube/tube 12mm x 12mm, body only

Steel pipes, brushes, left hand sweep

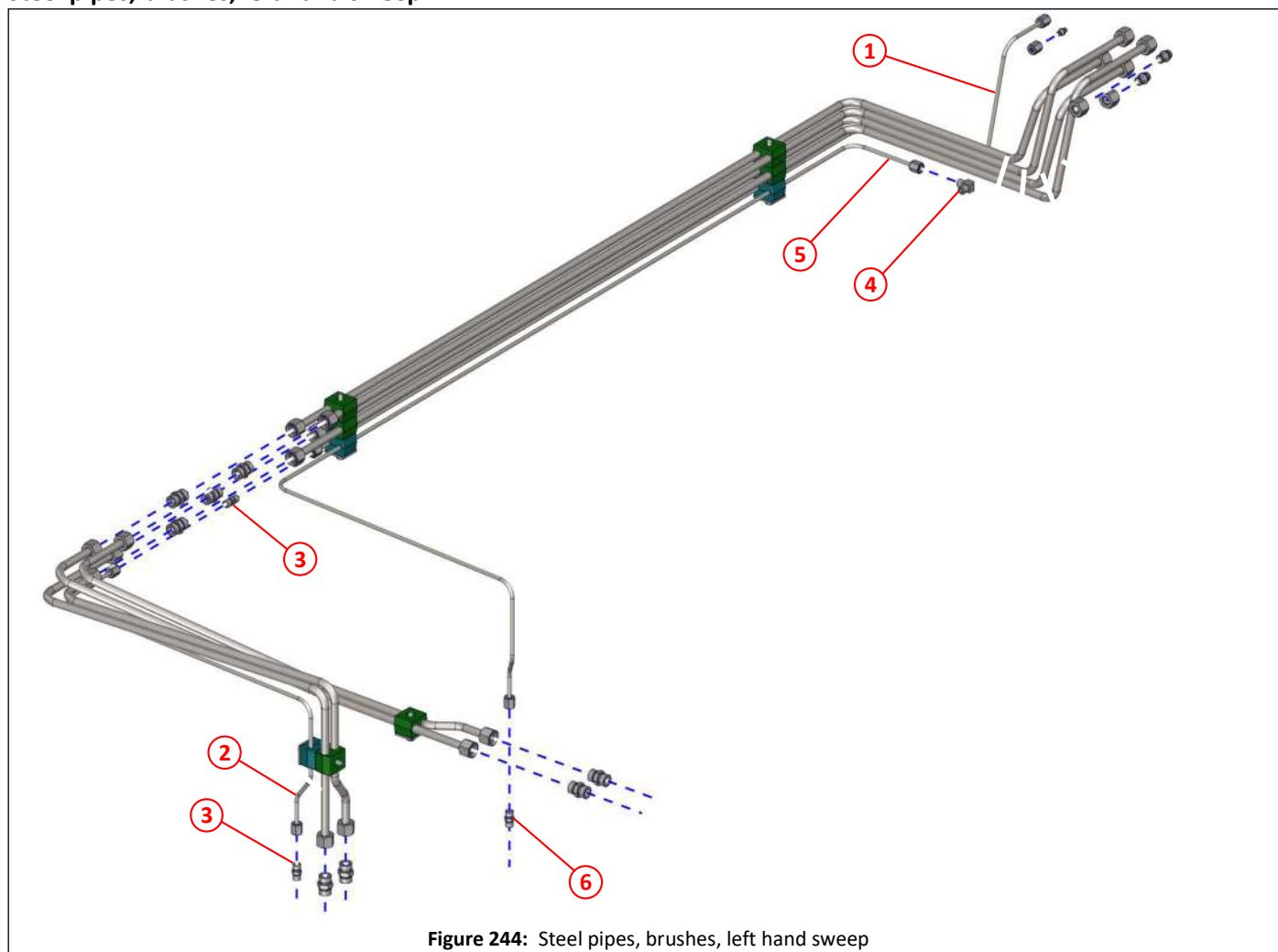

Figure 244: Steel pipes, brushes, left hand sweep

Item	Part No	Qty	Description
①	043409	1	Pipe, steel, lift, left hand side brush, part 1
②	043410	1	Pipe, steel, lift, left hand side brush, part 2
③	002052	2	Union tube/tube 6mm x 6mm, body only
④	002053	1	Union elbow 6mm x 6mm, body only
⑤	043411	1	Pipe, steel, tilt, left hand suction nozzle
⑥	002052	1	Union tube/tube 6mm x 6mm, body only



Clamp blocks, steel pipes, brushes, left hand sweep

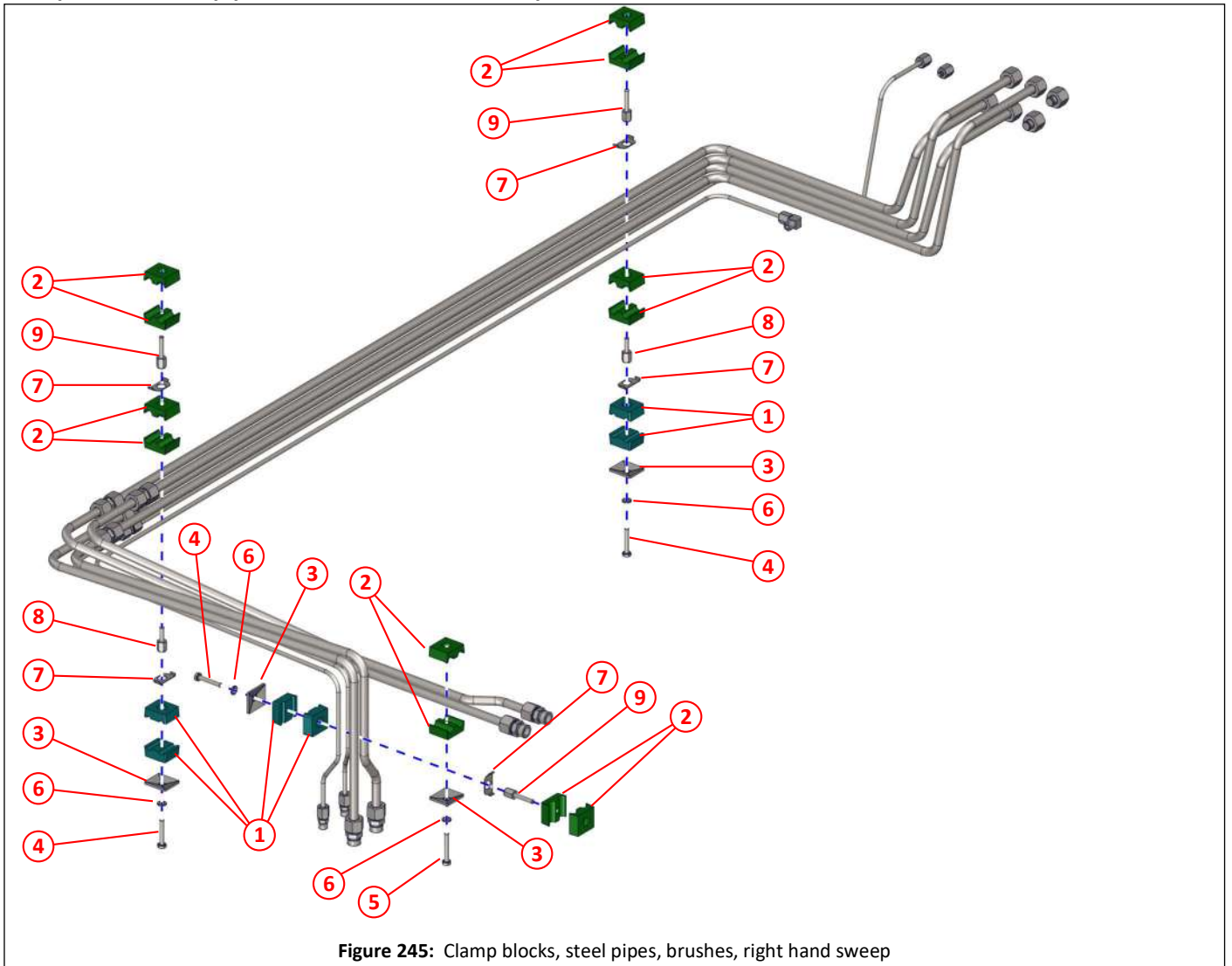

Figure 245: Clamp blocks, steel pipes, brushes, right hand sweep

Item	Part No	Qty	Description
①	027983	6	Pipe clamp block 6 x 6 double
②	027984	12	Pipe clamp block 12 x 12 double
③	027996	4	Pipe clamp top plate
④	011068	3	Bolt M6 x 35
⑤	000021	1	Set screw M6 x 40
⑥	011091	4	Spring washer M6
⑦	000472	5	Locking plate
⑧	000467	2	Stacking bolt 20mm (AF1)
⑨	000469	3	Stacking bolt 30mm (AF3)

Steel pipes, brushes, right hand sweep

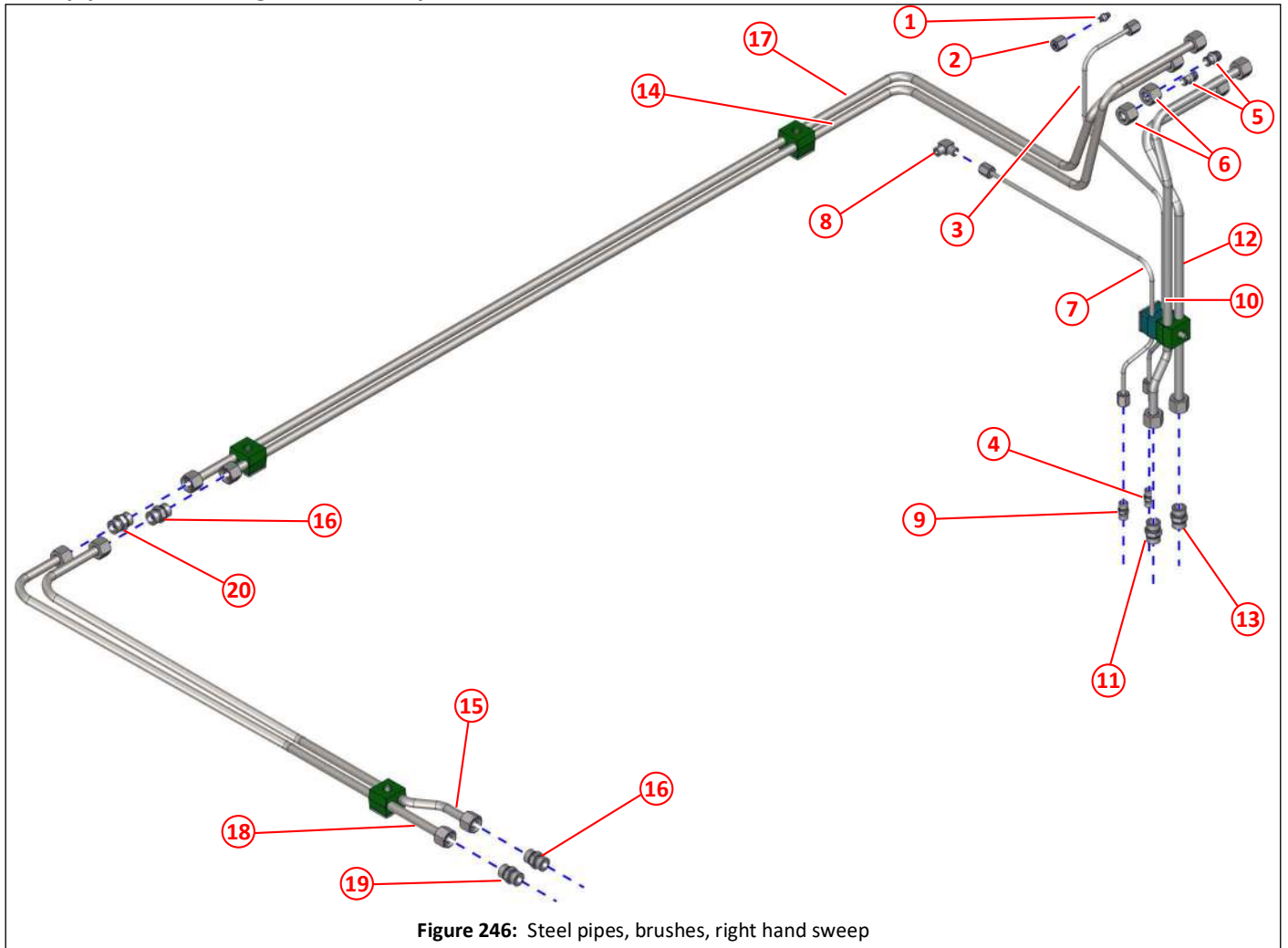

Figure 246: Steel pipes, brushes, right hand sweep

Item	Part No	Qty	Description
①	002235	1	Blanking plug 6mm
②	002132	1	Compression nut 6mm
③	043414	1	Pipe, steel, lift, right hand side brush
④	002052	1	Union tube/tube 6mm x 6mm, body only
⑤	002236	2	Blanking plug 12mm
⑥	002130	2	Compression nut 12mm
⑦	043415	1	Pipe, steel, tilt, right hand suction nozzle
⑧	002053	1	Union elbow 6mm x 6mm, body only
⑨	002052	1	Union tube/tube 6mm x 6mm, body only
⑩	043412	1	Pipe, steel, feed, right hand side brush
⑪	002088	1	Union tube/tube 12mm x 12mm, body only
⑫	043413	1	Pipe, steel, return, right hand side brush
⑬	002088	1	Union tube/tube 12mm x 12mm, body only
⑭	043416	1	Pipe, steel, feed, central brush (wide sweep), part 1
⑮	043417	1	Pipe, steel, feed, central brush (wide sweep), part 2
⑯	002088	2	Union tube/tube 12mm x 12mm, body only
⑰	043418	1	Pipe, steel, return, central brush (wide sweep), part 1
⑱	043419	1	Pipe, steel, return, central brush (wide sweep), part 2
⑲	002088	2	Union tube/tube 12mm x 12mm, body only

Clamp blocks, steel pipes, brushes, left hand sweep

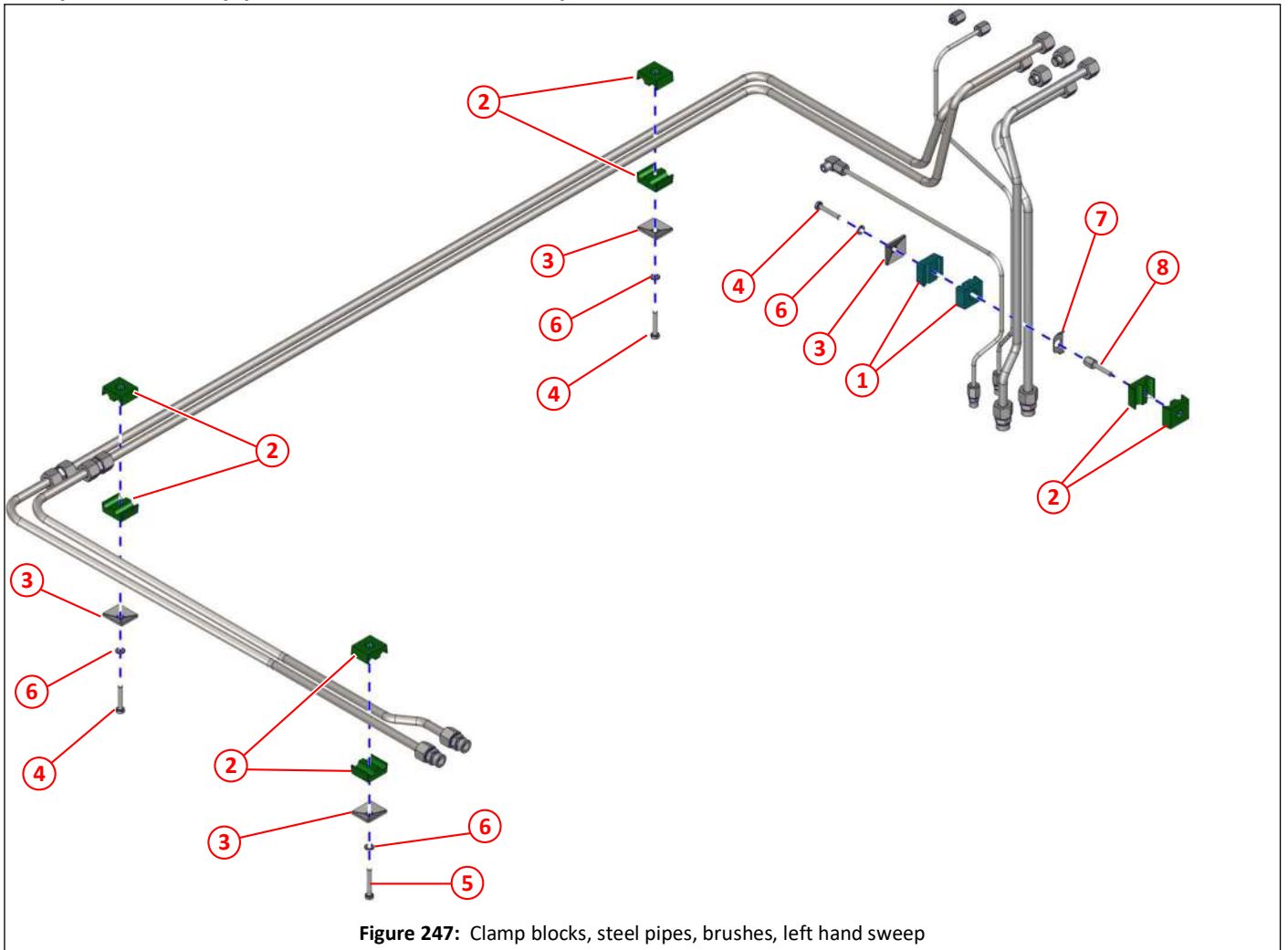

Figure 247: Clamp blocks, steel pipes, brushes, left hand sweep

Item	Part No	Qty	Description
①	027983	2	Pipe clamp block 6 x 6 double
②	027984	8	Pipe clamp block 12 x 12 double
③	027996	4	Pipe clamp top plate
④	011068	3	Bolt M6 x 35
⑤	000021	1	Set screw M6 x 40
⑥	011091	4	Spring washer M6
⑦	000472	1	Locking plate
⑧	000469	1	Stacking bolt 30mm (AF3)

## Steel pipes, options block

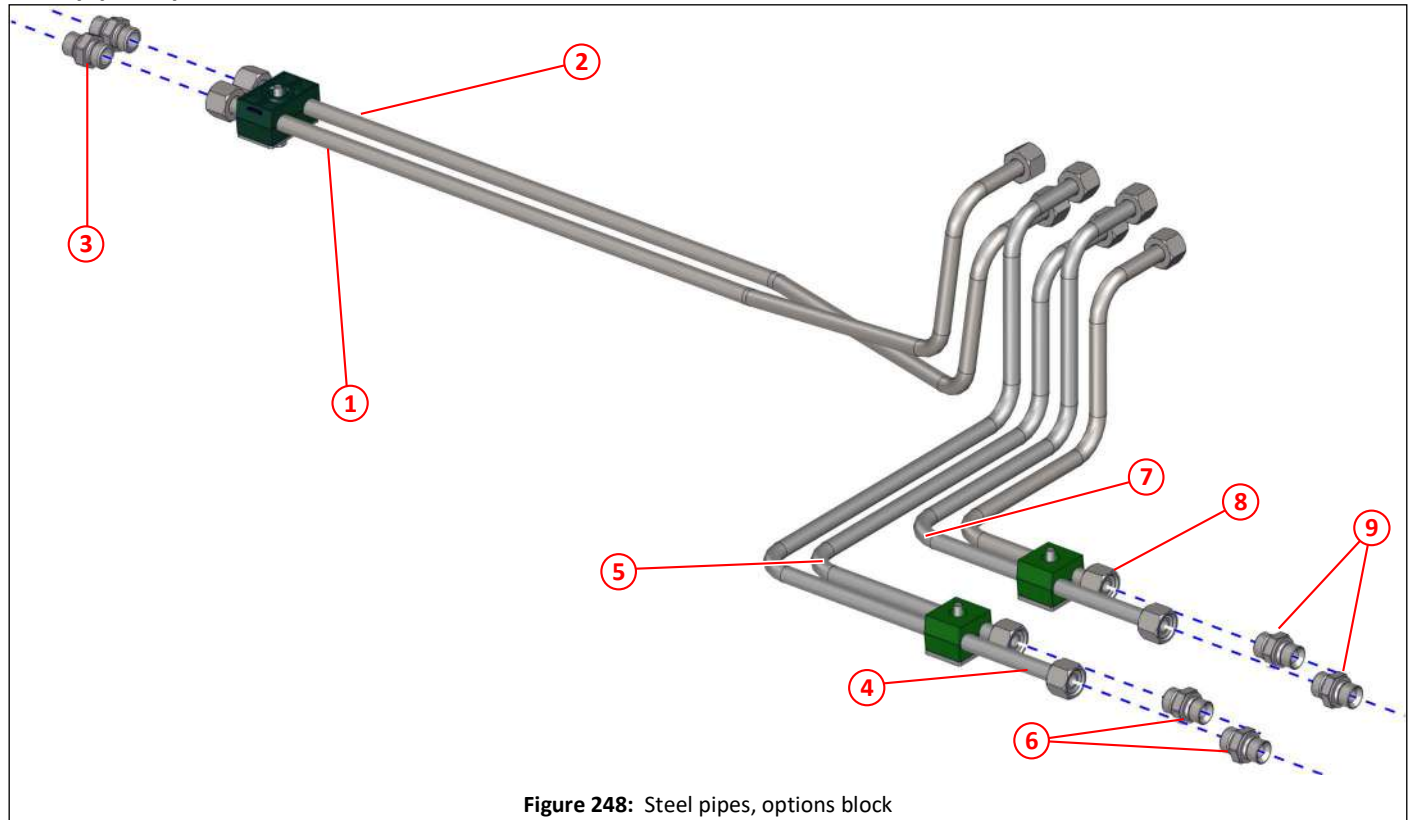

Figure 248: Steel pipes, options block

Item	Part No	Qty	Description
①	044676	1	Pipe, steel, feed, right hand auxiliary brush
②	044677	1	Pipe, steel, return, right hand auxiliary brush
③	020903	2	Adapter, M/M, 12 x $\frac{3}{8}$ " BSP
④	043401	1	Pipe, steel, feed, motor, high pressure water pump
⑤	043402	1	Pipe, steel, return, motor, high pressure water pump
⑥	020903	2	Adapter, M/M, 12 x $\frac{3}{8}$ " BSP
⑦	043399	1	Pipe, steel, feed, motor, low pressure water pump
⑧	043400	1	Pipe, steel, return, motor, low pressure water pump
⑨	020903	2	Adapter, M/M, 12 x $\frac{3}{8}$ " BSP

Clamp blocks, steel pipes, options block

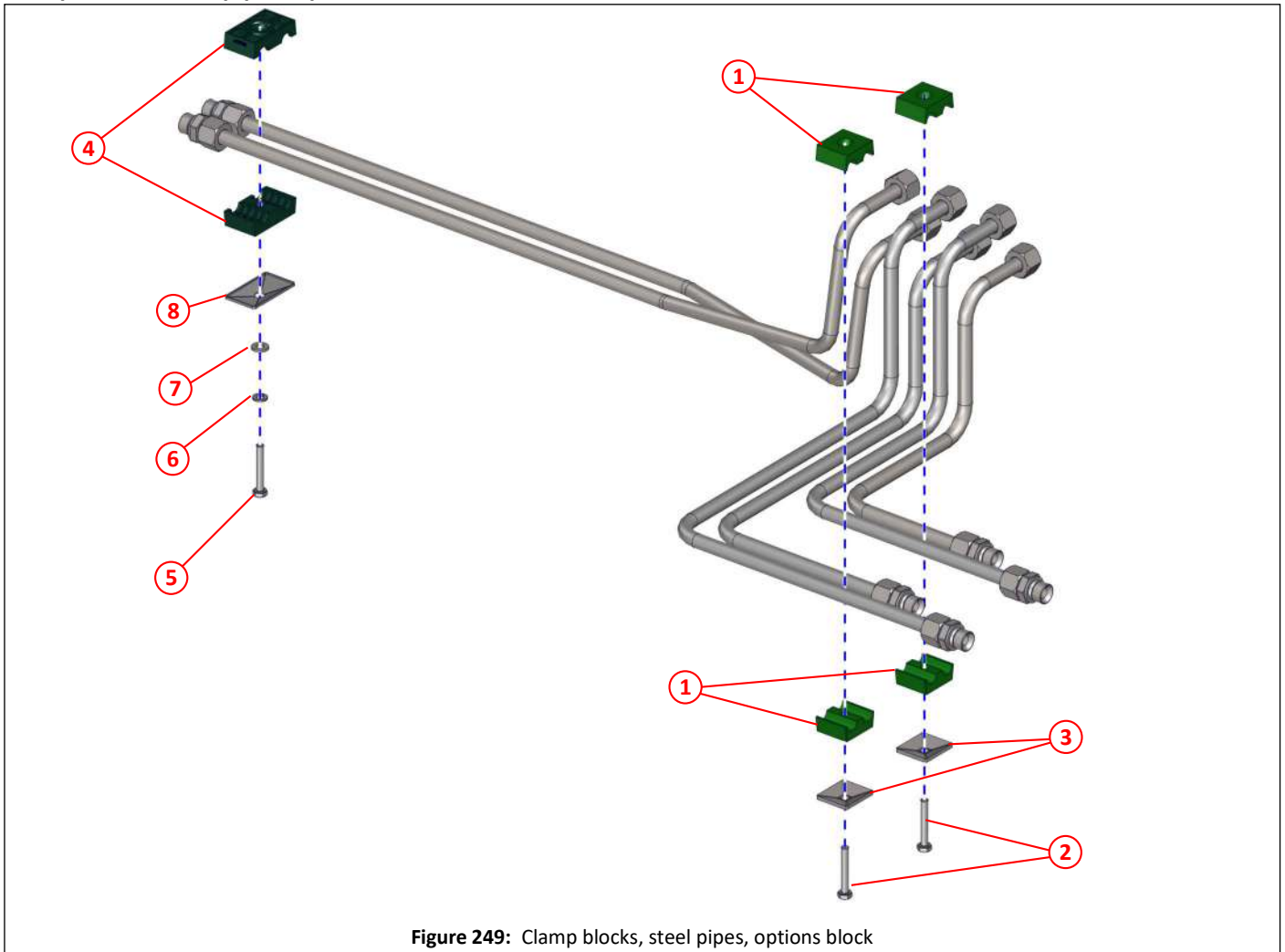

Figure 249: Clamp blocks, steel pipes, options block

Item	Part No	Qty	Description
①	027984	4	Pipe clamp block 12 x 12 double
②	000021	2	Set screw M6 x 40
③	027996	2	Pipe clamp top plate
④	043590	2	Pipe clamp block 12.7 x 12.7 double
⑤	000021	1	Set screw M6 x 40
⑥	011091	1	Spring washer M6
⑦	011090	1	Plain washer M6
⑧	031919	1	Clamp plate flat

Steel pipes, suction fan and rear door open/close/lock

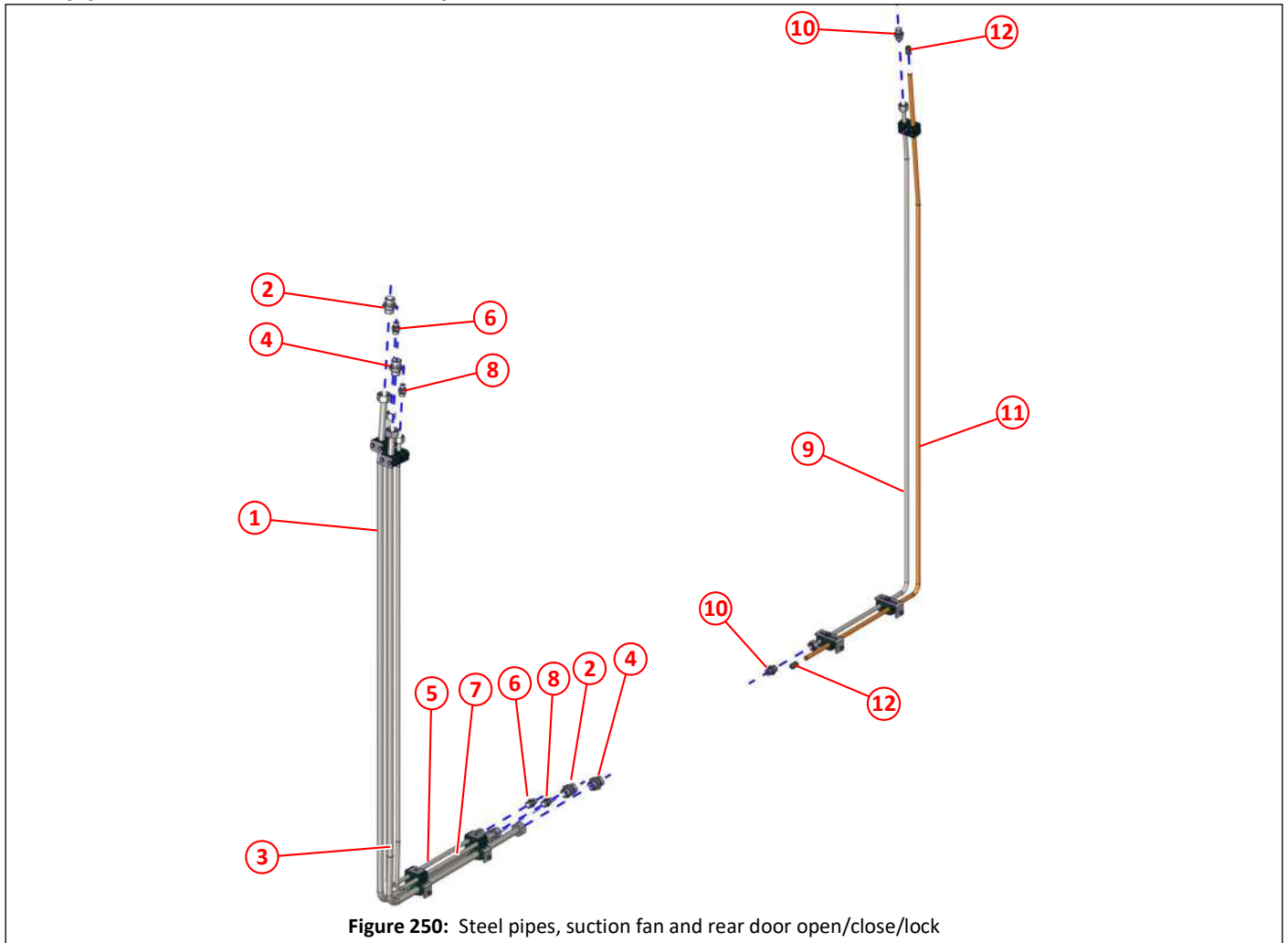

Figure 250: Steel pipes, suction fan and rear door open/close/lock

Item	Part No	Qty	Description
①	043602	1	Pipe, steel, feed, suction fan motor
②	002017	2	Adapter, compression, M/M, 18mm x $\frac{3}{4}$ " BSP
③	043603	1	Pipe, steel, return, suction fan motor
④	002117	2	Adapter, compression, M/M, 18mm x $\frac{3}{4}$ " BSP
⑤	043605	1	Pipe, steel, rear door open
⑥	002086	2	Adapter, M/M, 12 x $\frac{1}{4}$ " BSP
⑦	043606	1	Pipe, steel, rear door close/lock
⑧	002086	2	Adapter, M/M, 12 x $\frac{1}{4}$ " BSP
⑨	043604	1	Pipe, steel, suction fan motor case drain
⑩	020903	2	Adapter, M/M, 12 x $\frac{3}{8}$ " BSP
⑪	043607	1	Hopper loom rail
⑫	043065	2	Pipe cap, $\phi 12$



Clamp blocks, steel pipes, suction fan and rear door open/close/lock

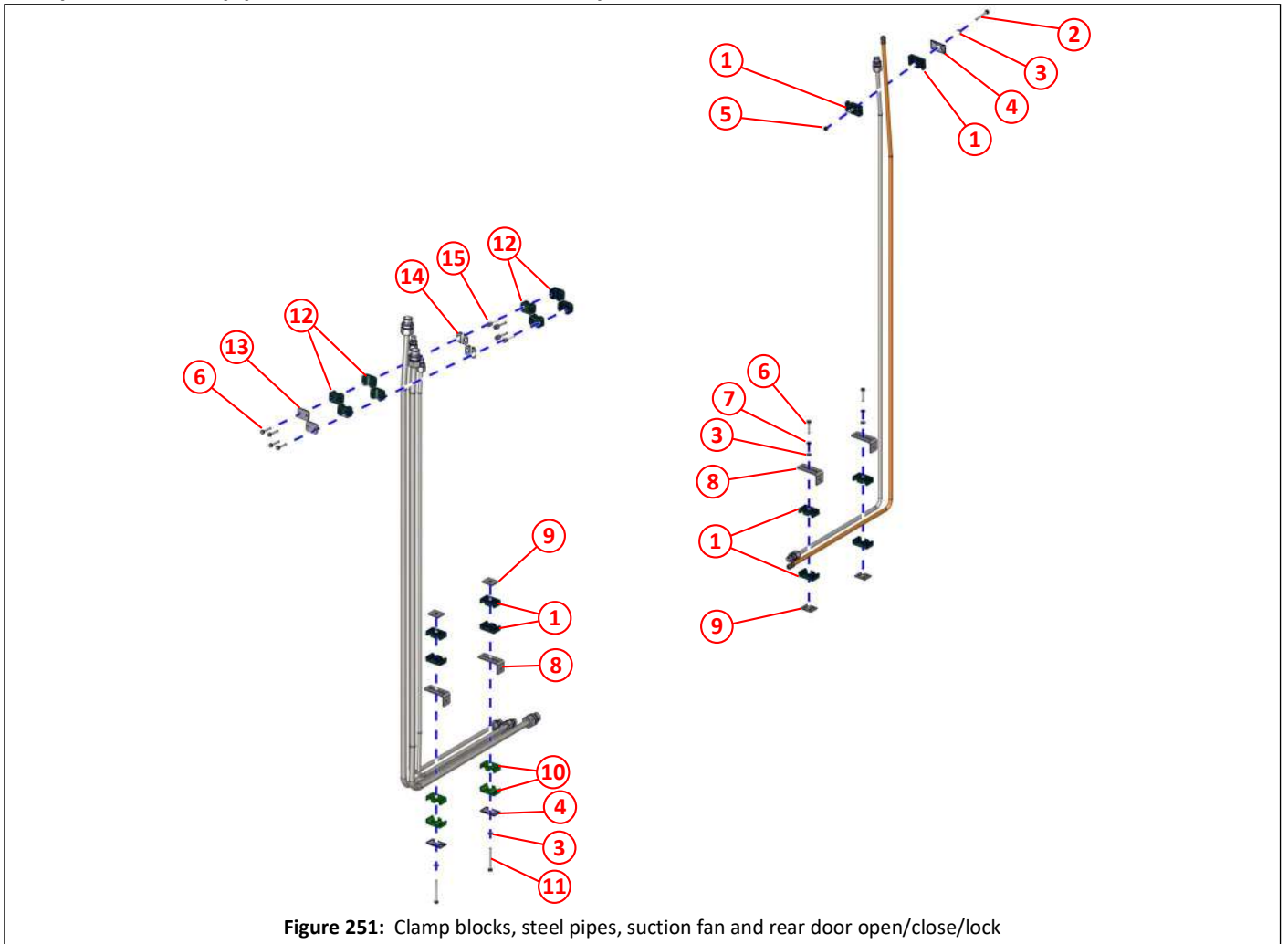

Figure 251: Clamp blocks, steel pipes, suction fan and rear door open/close/lock

Item	Part No	Qty	Description
①	043590	10	Pipe clamp block 12.7 x 12.7 double
②	011003	1	Set screw M6 x 50
③	011090	5	Plain washer M6
④	031919	3	Clamp plate flat
⑤	011071	1	Nyloc nut M6
⑥	011068	6	Bolt M6 x 35
⑦	011091	2	Spring washer M6
⑧	026196	4	Bracket, anti-vibration
⑨	027993	4	Pipe clamp bottom plate, small
⑩	027988	4	Pipe clamp block 18 x 18 double
⑪	011143	2	Set screw M6 x 70
⑫	042796	8	Pipe clamp block 18 x 18 double
⑬	031317	2	Clamp plate flat
⑭	000472	4	Locking plate
⑮	000470	4	Stacking bolt 35mm (AF4)



# Pneumatics

<i>Description</i>	<i>Page</i>
Pneumatic control valves, pre August 2017, 24v system .....	292
Pneumatic control block and valves, high temperature .....	294
5/2 HT spring valve body and 15mm HT solenoid valve .....	296
5/2 HT spring valve body .....	297
15mm HT solenoid valve, .....	298
5/2 pilot/pilot HT valve .....	299
5/3 pilot/pilot HT valve .....	300
Valve, OR gate .....	301
Seals and gaskets .....	302
Breather and relief valves .....	303
Pneumatic regulator and filter .....	304
Pressure regulator valve, central brush (wide sweep) .....	305
Pressure regulator valve side brush and switches for brush pressure (cab mounted) .....	306
Central brush (wide sweep), raise/lower/pressure .....	307
Central brush (wide sweep), slewing .....	308
Suction nozzle, raise/lower .....	309
Side brush, swing in/out .....	310
Side brush, pressure .....	311
Auto blanking .....	312
Auxiliary brush, raise/lower .....	313
Auxiliary brush, left hand, swing in/out .....	314
Auxiliary brush, extend/retract .....	315
Hopper safety prop, kicker .....	316

Pneumatic control valves, pre August 2017, 24v system

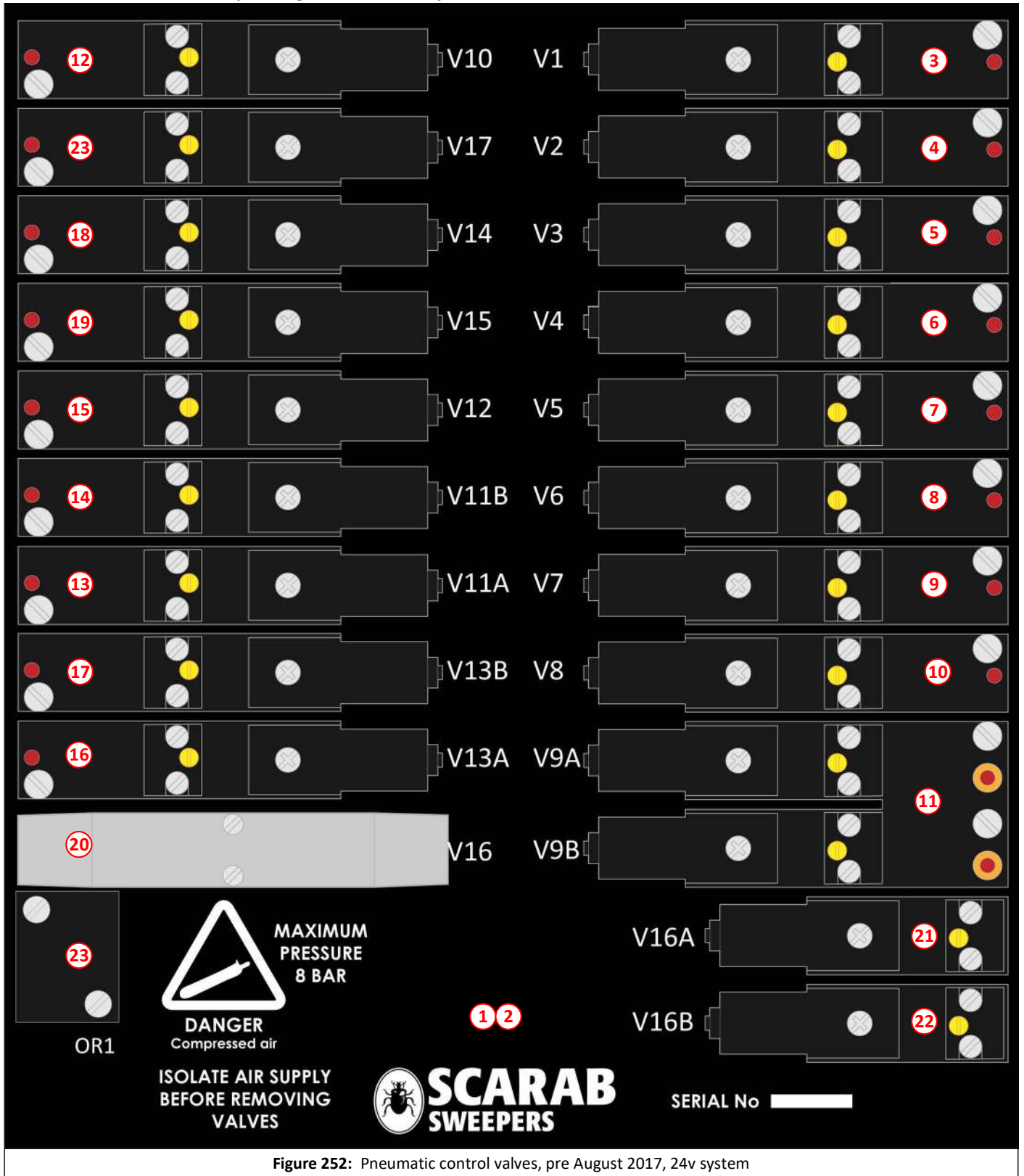

Figure 252: Pneumatic control valves, pre August 2017, 24v system

Pneumatic control valves, pre August 2017, 24v system

Item	Part No	Qty	Description
①	034631	1	Pneumatic control block, populated
②		1	Pneumatic control block, bare
③	035673	1	V1 - 4/2 pilot spring valve and solenoid
④	035673	1	V2 - 4/2 pilot spring valve and solenoid
⑤	035673	1	V3 - 4/2 pilot spring valve and solenoid
⑥	035673	1	V4 - 4/2 pilot spring valve and solenoid
⑦	035673	1	V5 - 4/2 pilot spring valve and solenoid
⑧	035673	1	V6 - 4/2 pilot spring valve and solenoid
⑨	035673	1	V7 - 4/2 pilot spring valve and solenoid
⑩	035673	1	V8 - 4/2 pilot spring valve and solenoid
⑪	035674	1	V9A&B - 4/2 pilot/pilot valve and solenoid
⑫	035673	1	V10 - 4/2 pilot spring valve and solenoid
⑬	035673	1	V11A - 4/2 pilot spring valve and solenoid
⑭	035673	1	V11B - 4/2 pilot spring valve and solenoid
⑮	035673	1	V12 - 4/2 pilot spring valve and solenoid
⑯	035673	1	V13A - 4/2 pilot spring valve and solenoid
⑰	035673	1	V13B - 4/2 pilot spring valve and solenoid
⑱	035673	1	V14 - 4/2 pilot spring valve and solenoid
⑲	035673	1	V15 - 4/2 pilot spring valve and solenoid
⑳	035675	1	V16 - 5/3 pilot/pilot valve and solenoid
㉑	035685	1	V16A - valve and solenoid
㉒	035685	1	V16B - valve and solenoid
㉓	032710	1	OR1 - OR gate valve
NI	035653	AR	Blanking plate, used in place of 035673
NI	035671	1	Blanking plate, used in place of 035675
NI	035672	1	Blanking plate, used in place of 032710

Pneumatic control block and valves, high temperature

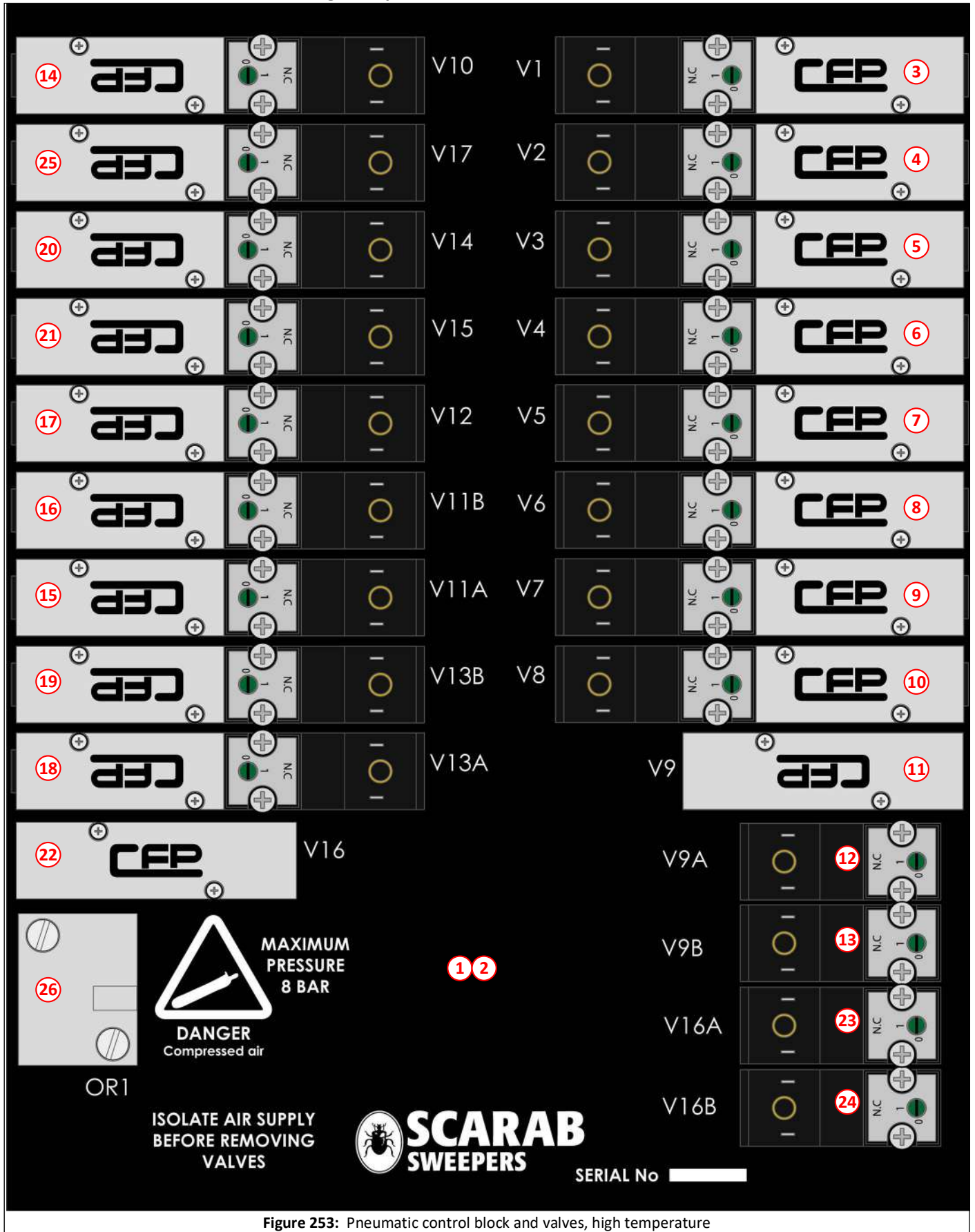

Figure 253: Pneumatic control block and valves, high temperature

**i** Please note the following table and pages have both 24v and 12v components. Please ensure you select the correct voltage part for your vehicle.



**Pneumatic control block and valves, high temperature**

Item	Part No	Qty	Description
①	045293	1	Pneumatic control block (HAF), populated, 24v
①	045303	1	Pneumatic control block (HAF), populated, 12v
②	045474	1	Pneumatic control block (HAF), bare
③	045385	1	V1 - 5/2 HT solenoid & spring valve 24v, LH side brush in/out
③	045406	1	V1 - 5/2 HT solenoid & spring valve 12v, LH side brush in/out
④	045385	1	V2 - 5/2 HT solenoid & spring valve 24v, LH suction nozzle lift/lower
④	045406	1	V2 - 5/2 HT solenoid & spring valve 12v, LH suction nozzle lift/lower
⑤	045385	1	V3 - 5/2 HT solenoid & spring valve 24v, LH auto blanking flap open/close
⑤	045406	1	V3 - 5/2 HT solenoid & spring valve 12v, LH auto blanking flap open/close
⑥	045385	1	V4 - 5/2 HT solenoid & spring valve 24v, RH auto blanking flap open/close
⑥	045406	1	V4 - 5/2 HT solenoid & spring valve 12v, RH auto blanking flap open/close
⑦	045385	1	V5 - 5/2 HT solenoid & spring valve 24v, RH suction nozzle open/close
⑦	045406	1	V5 - 5/2 HT solenoid & spring valve 12v, RH suction nozzle open/close
⑧	045385	1	V6 - 5/2 HT solenoid & spring valve 24v, RH side brush in/out
⑧	045406	1	V6 - 5/2 HT solenoid & spring valve 12v, RH side brush in/out
⑨	045385	1	V7 - 5/2 HT solenoid & spring valve 24v, central brush (wide sweep) swivel/slew
⑨	045406	1	V7 - 5/2 HT solenoid & spring valve 12v, central brush (wide sweep) swivel/slew
⑩	045385	1	V8 - 5/2 HT solenoid & spring valve 24v, rear boom flap
⑩	045406	1	V8 - 5/2 HT solenoid & spring valve 12v, rear boom flap
⑪	045383	1	V9 - 5/2 HT pilot/pilot valve, full pressure side brush
⑫	045381	1	V9A - 5/2 HT 15mm solenoid 24v, full pressure side brush down
⑫	045382	1	V9A - 5/2 HT 15mm solenoid 12v, full pressure side brush down
⑬	045381	1	V9B - 5/2 HT 15mm solenoid 24v, full pressure side brush up
⑬	045382	1	V9B - 5/2 HT 15mm solenoid 12v, full pressure side brush up
⑭	045385	1	V10 - 5/2 HT solenoid & spring valve 24v, hopper prop
⑭	045406	1	V10 - 5/2 HT solenoid & spring valve 12v, hopper prop
⑮	045385	1	V11A - 5/2 HT solenoid & spring valve 24v, side brush pressure up
⑮	045406	1	V11A - 5/2 HT solenoid & spring valve 12v, side brush pressure up
⑯	045385	1	V11B - 5/2 HT solenoid & spring valve 24v, side brush pressure down
⑯	045406	1	V11B - 5/2 HT solenoid & spring valve 12v, side brush pressure down
⑰	045385	1	V12 - 5/2 HT solenoid & spring valve 24v, central brush (wide sweep) lift/lower
⑰	045406	1	V12 - 5/2 HT solenoid & spring valve 12v, central brush (wide sweep) lift/lower
⑱	045385	1	V13A - 5/2 HT solenoid & spring valve 24v, central brush (wide sweep) up pressure
⑱	045406	1	V13A - 5/2 HT solenoid & spring valve 12v, central brush (wide sweep) up pressure
⑲	045385	1	V13B - 5/2 HT solenoid & spring valve 24v, central brush (wide sweep) down pressure
⑲	045406	1	V13B - 5/2 HT solenoid & spring valve 12v, central brush (wide sweep) down pressure
⑳	045385	1	V14 - 5/2 HT solenoid & spring valve 24v, auxiliary brush slide out
⑳	045406	1	V14 - 5/2 HT solenoid & spring valve 12v, auxiliary brush slide out
㉑	045385	1	V15 - 5/2 HT solenoid & spring valve 24v, auxiliary brush lower
㉑	045406	1	V15 - 5/2 HT solenoid & spring valve 12v, auxiliary brush lower
㉒	045384	1	V16 - 5/3 HT pilot/pilot valve, air operated rear boom
㉓	045381	1	V16A - 5/2 HT 15mm solenoid 24v, air operated rear boom raise
㉓	045382	1	V16A - 5/2 HT 15mm solenoid 12v, air operated rear boom raise
㉔	045381	1	V16B - 5/2 HT 15mm solenoid 24v, air operated rear boom lower
㉔	045382	1	V16B - 5/2 HT 15mm solenoid 12v, air operated rear boom lower
㉕	045385	1	V17 - 5/2 HT solenoid/spring valve 24v, auxiliary brush swing in/out
㉕	045406	1	V17 - 5/2 HT solenoid/spring valve 12v, auxiliary brush swing in/out
㉖	032710	1	OR1 - OR gate valve

5/2 HT spring valve body and 15mm HT solenoid valve

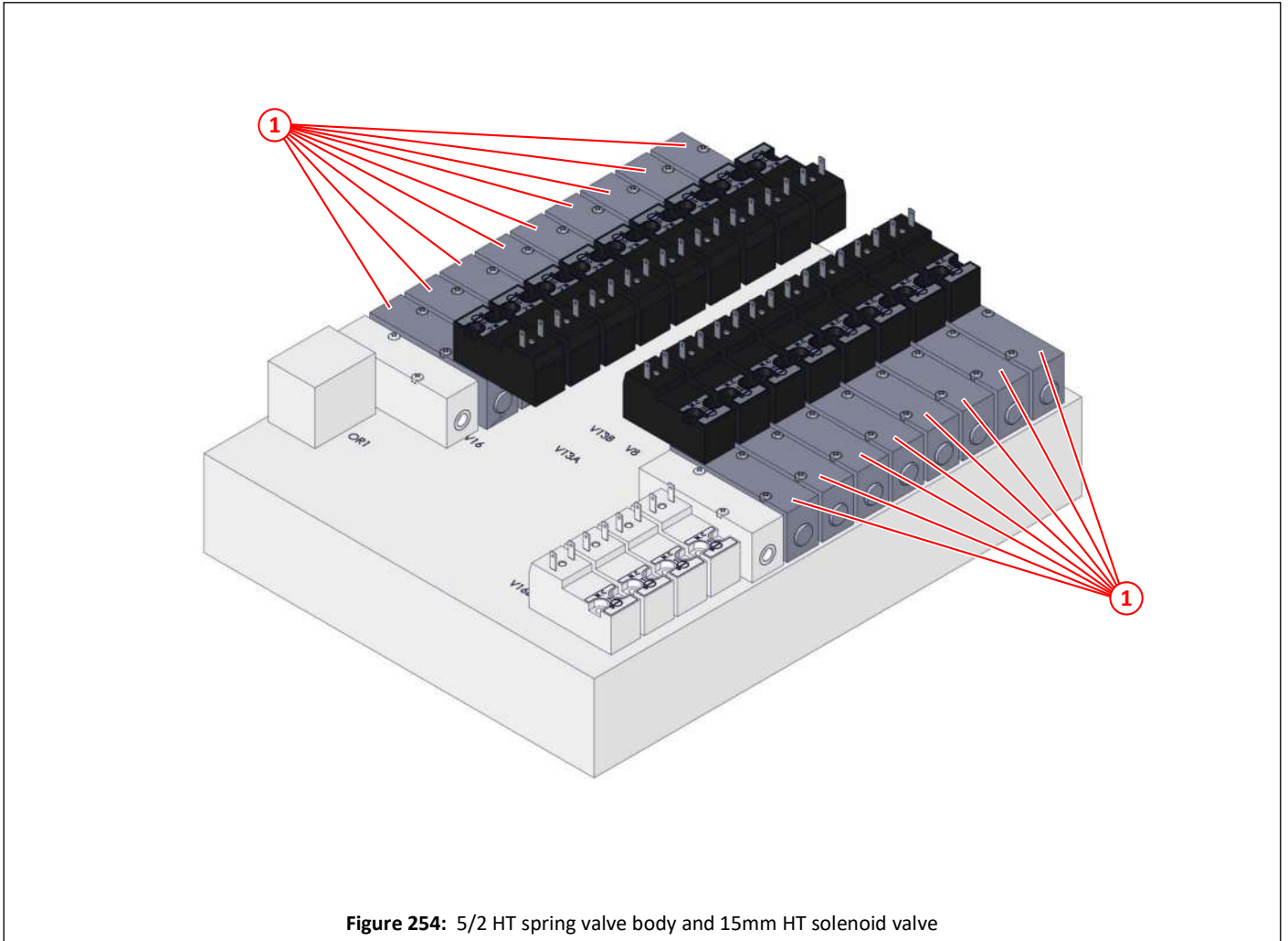

Figure 254: 5/2 HT spring valve body and 15mm HT solenoid valve

Item	Part No	Qty	Description	
①	045385	17	5/2 HT spring valve body and 15mm HT solenoid valve, 24v	
①	045406	17	5/2 HT spring valve body and 15mm HT solenoid valve, 12v	

5/2 HT spring valve body

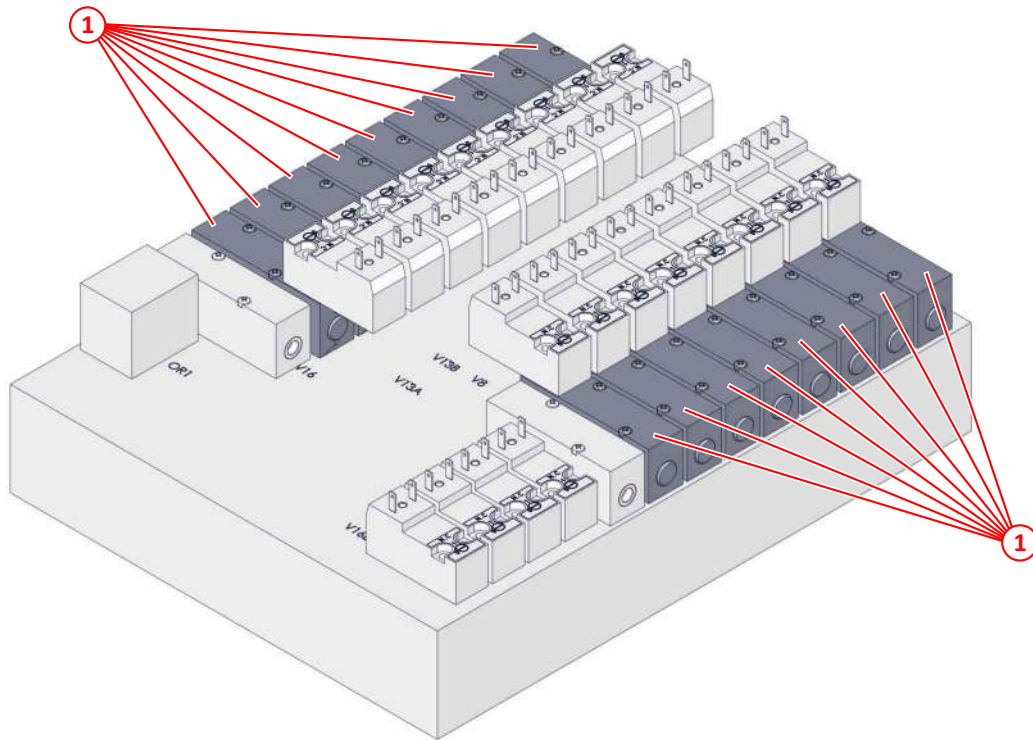

Figure 255: 5/2 HT spring valve body

Item	Part No	Qty	Description	
①	045386	17	5/2 HT spring valve body	

15mm HT solenoid valve,

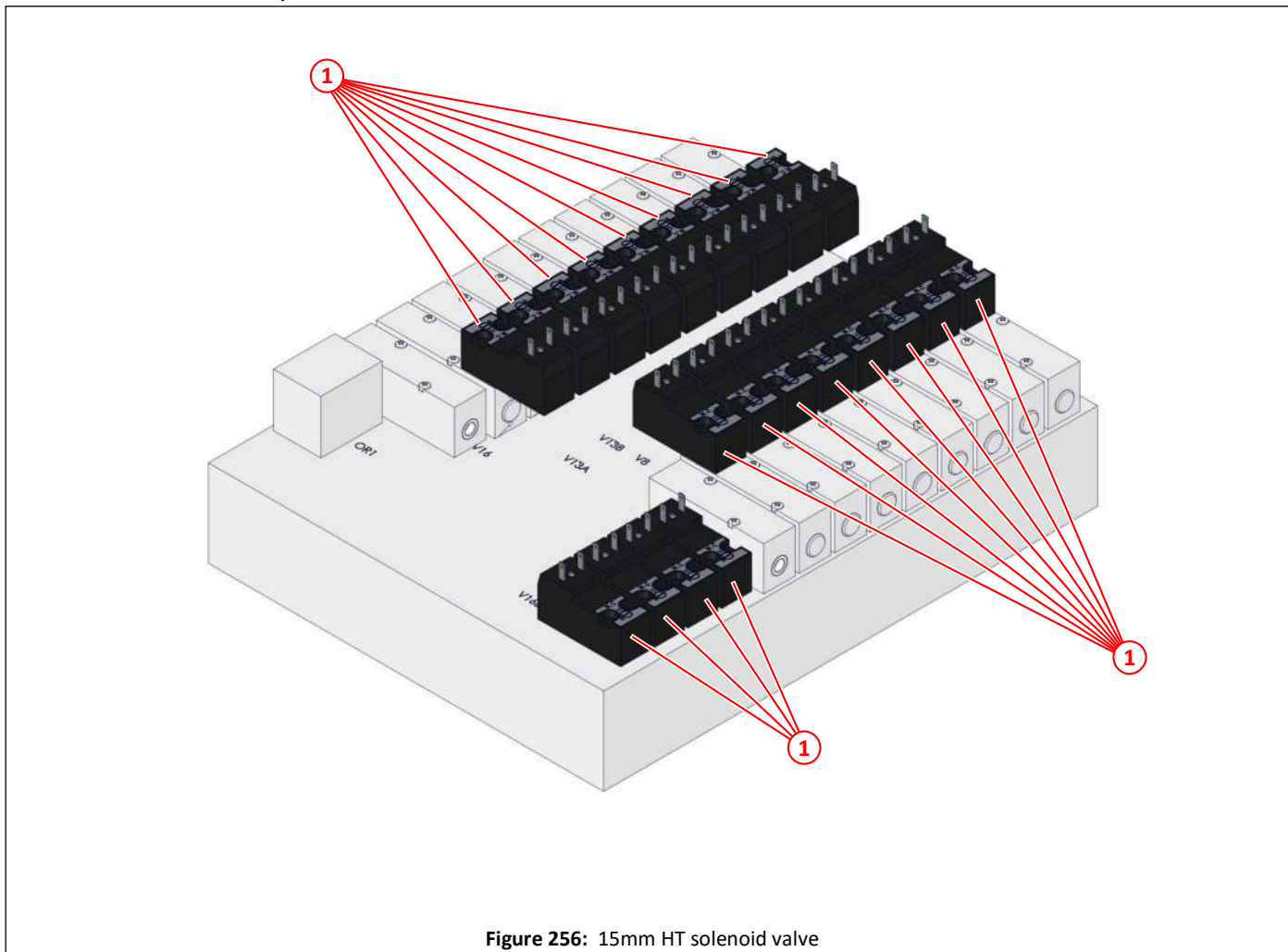

Figure 256: 15mm HT solenoid valve

Item	Part No	Qty	Description	
①	045381	21	15mm HT solenoid valve, 24v	
①	045382	21	15mm HT solenoid valve, 12v	

5/2 pilot/pilot HT valve

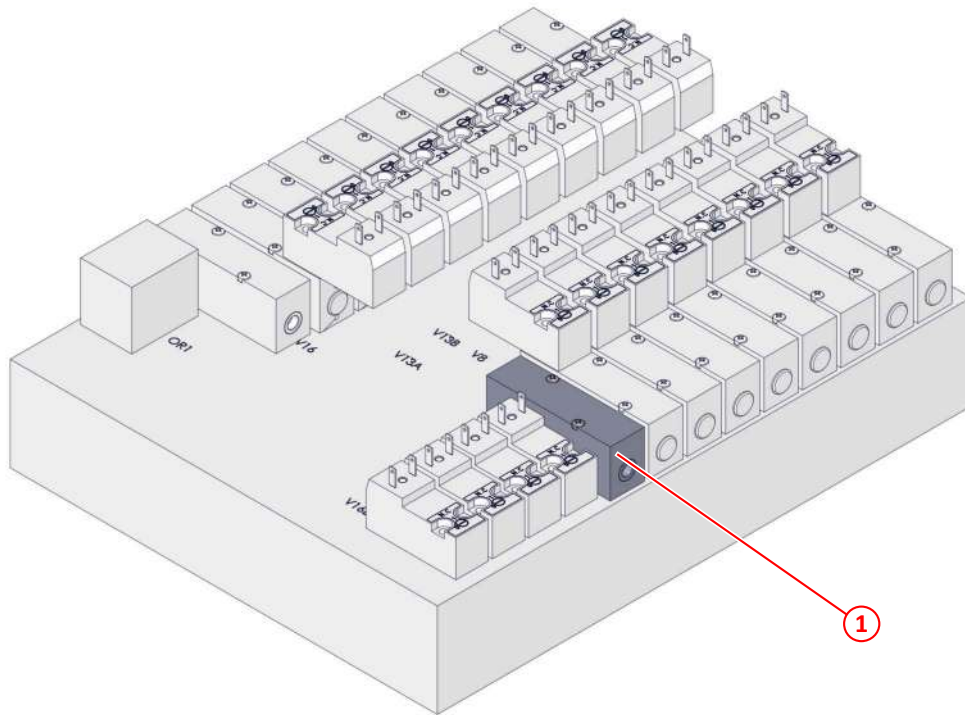

Figure 257: 5/2 pilot/pilot HT valve

Item	Part No	Qty	Description	
①	045383	1	5/2 pilot/pilot HT valve	

5/3 pilot/pilot HT valve

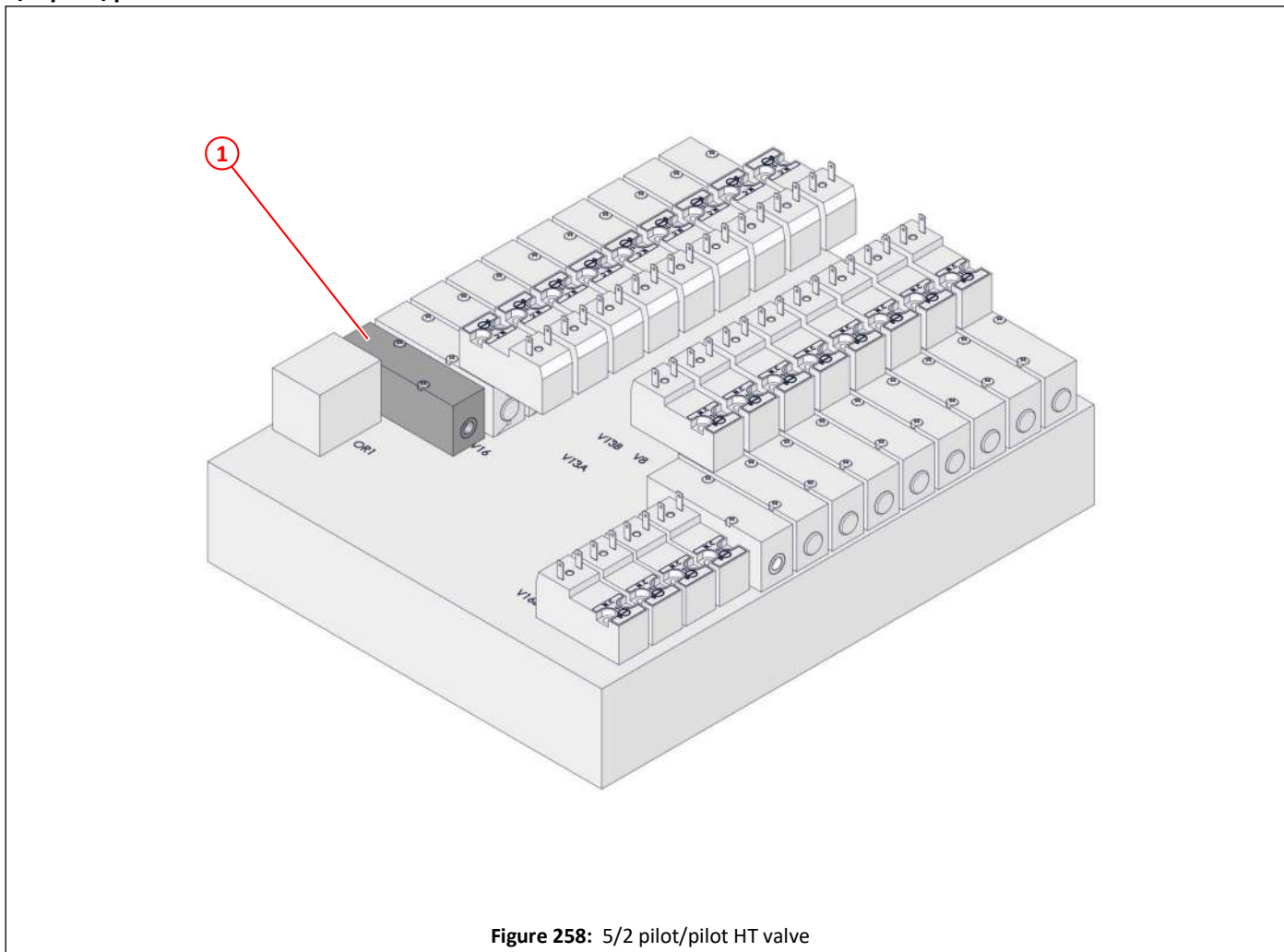

Figure 258: 5/2 pilot/pilot HT valve

Item	Part No	Qty	Description	
①	045384	1	5/3 pilot/pilot HT valve	



Valve, OR gate

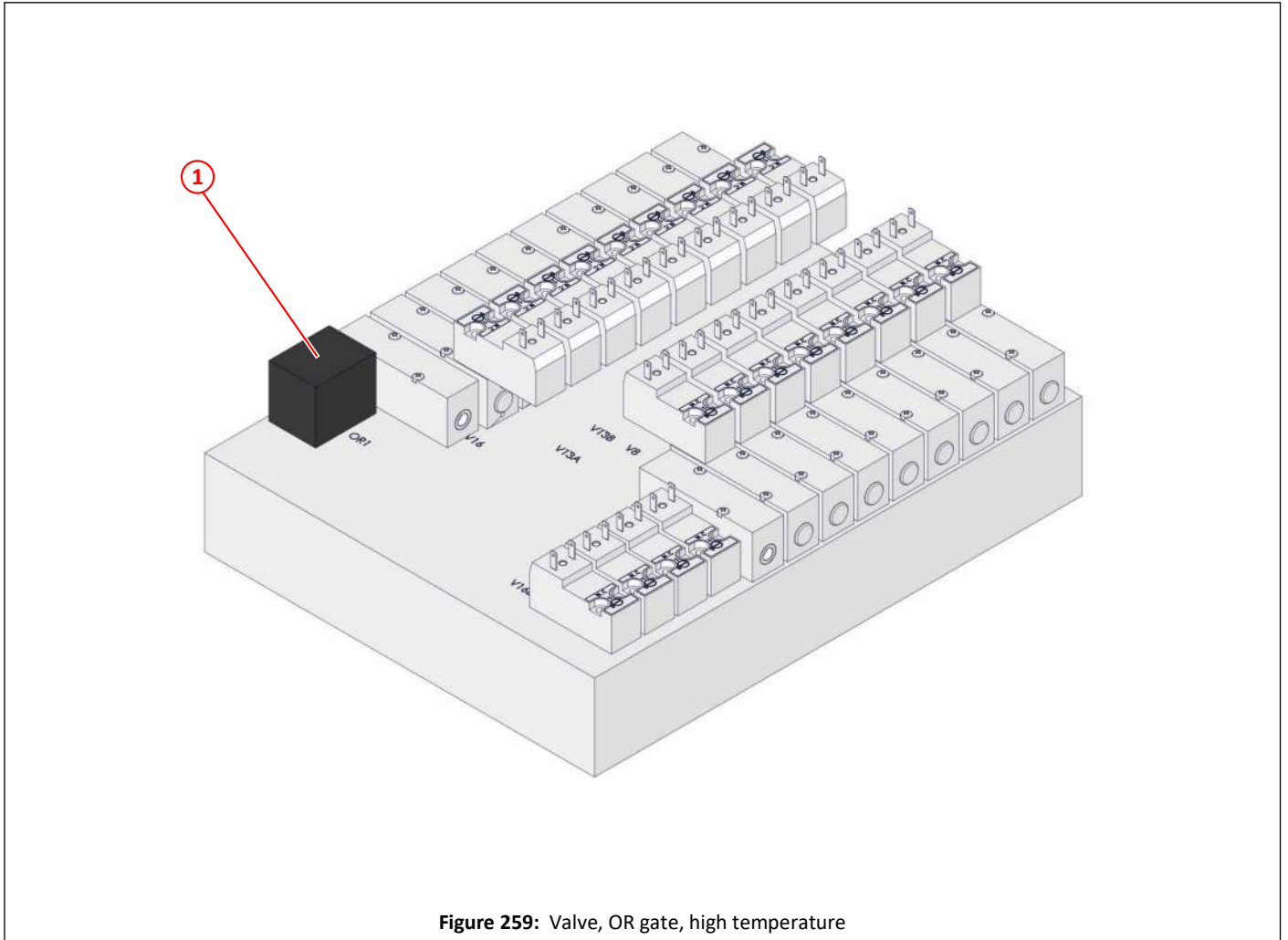

Figure 259: Valve, OR gate, high temperature

Item	Part No	Qty	Description	
①	032710	1	Valve, OR gate	

Seals and gaskets

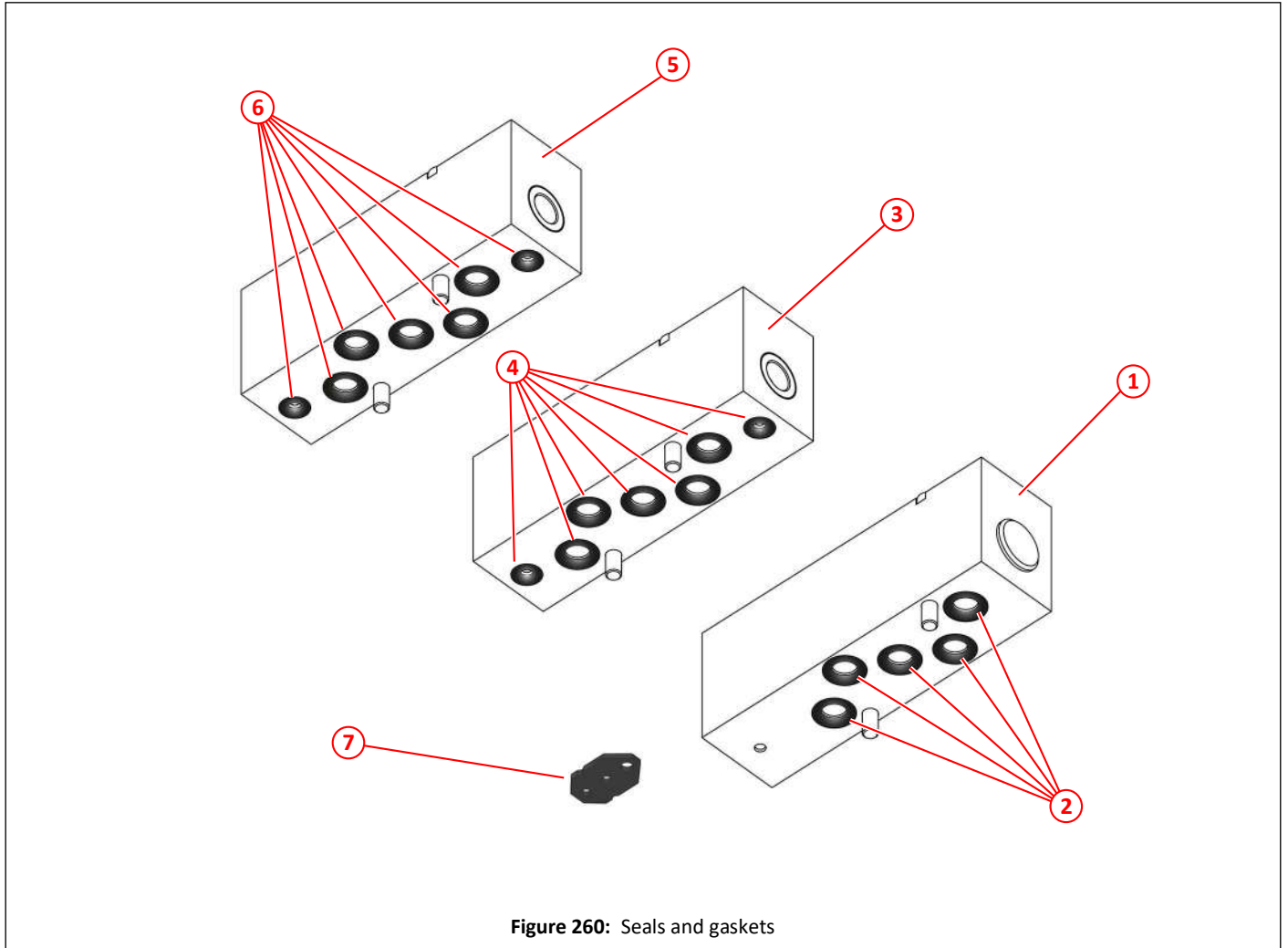

Figure 260: Seals and gaskets

Item	Part No	Qty	Description	
①	045386	17	5/2 HT spring valve body	297
②	045388	1	Seal kit for item ①, contains 5 of $\varnothing 4 \times \varnothing 1.5$ o-rings	
③	045383	1	5/2 pilot/pilot HT valve	299
④	045389	1	Seal kit for item ③, contains 5 of $\varnothing 4 \times \varnothing 1.5$ & 2 of $\varnothing 2 \times \varnothing 1.5$ o-rings	
⑤	045384	1	5/3 pilot/pilot HT valve	300
⑥	045390	1	Seal kit for item ⑤, contains 5 of $\varnothing 4 \times \varnothing 1.5$ & 2 of $\varnothing 2 \times \varnothing 1.5$ o-rings	
⑦	045387	1	Spare pilot solenoid gasket	

Breather and relief valves

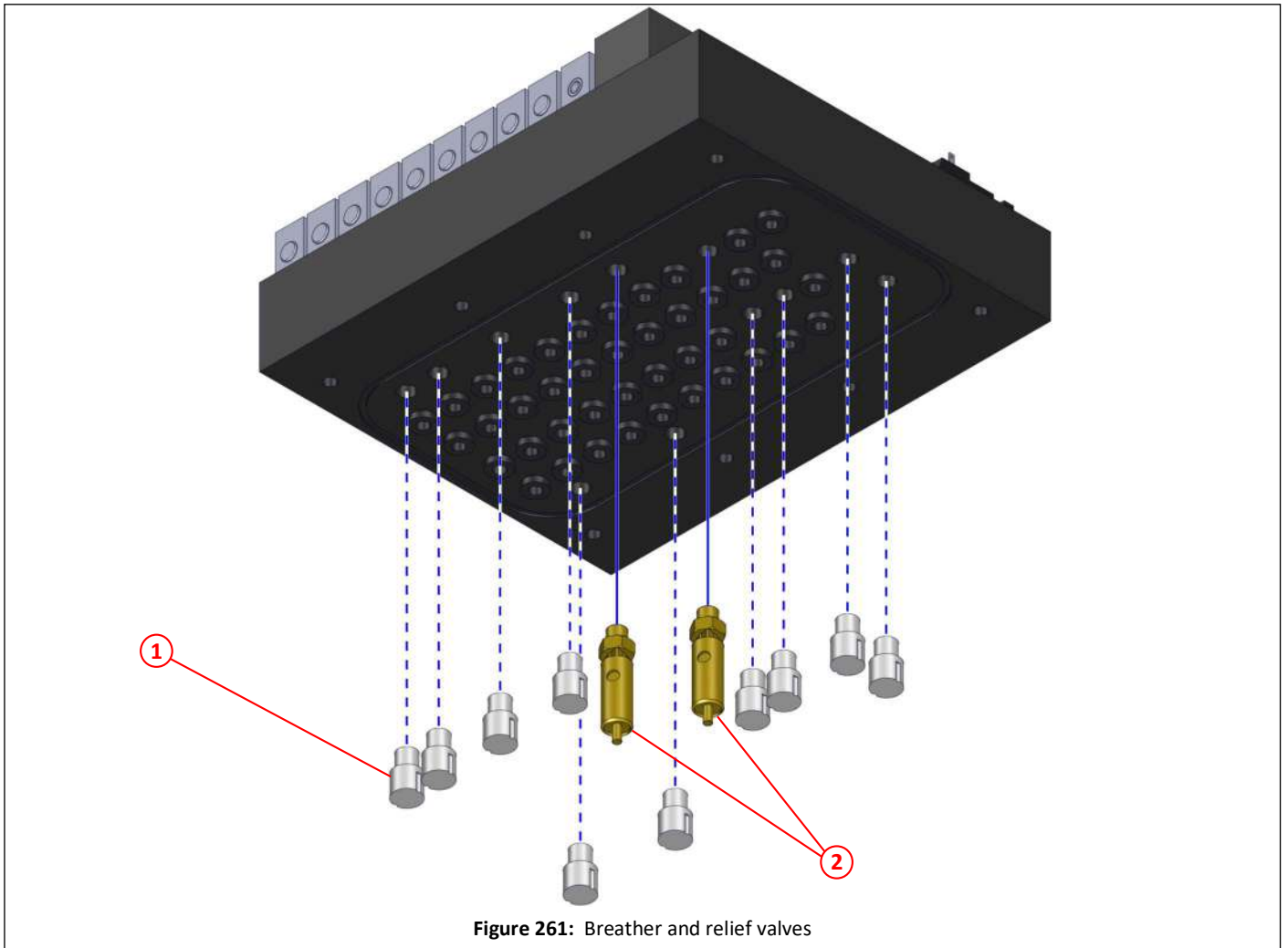

Figure 261: Breather and relief valves

Item	Part No	Qty	Description
①	006067	11	$\frac{1}{8}$ " one way breather valve
②	032709	2	Relief valve

Pneumatic regulator and filter

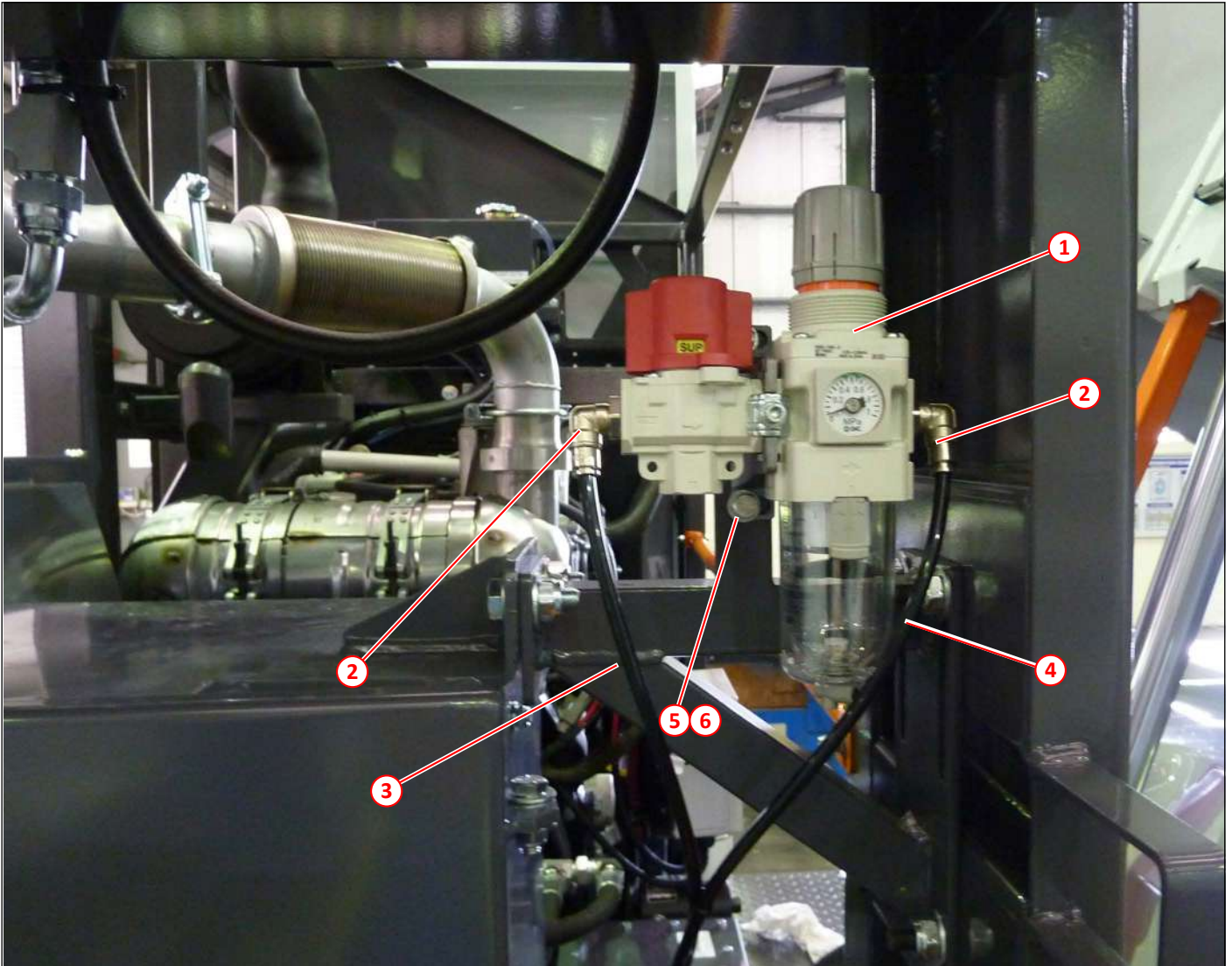

Figure 262: Pneumatic regulator and filter

Item	Part No	Qty	Description	
①	032519	1	Air regulator and filter, includes item ②	342
②	023203	2	Elbow, swivel, 1/4" BSP x 6 push in	
③	014572	As req	Air pipe, black, ø6, main feed from chassis unit	
④	014572	As req	Air pipe, black, ø6, to pneumatic valve block Port 35	
⑤	011067	2	Set screw M6 x 20	
⑥	011090	2	Plain washer M6	

Pressure regulator valve, central brush (wide sweep)

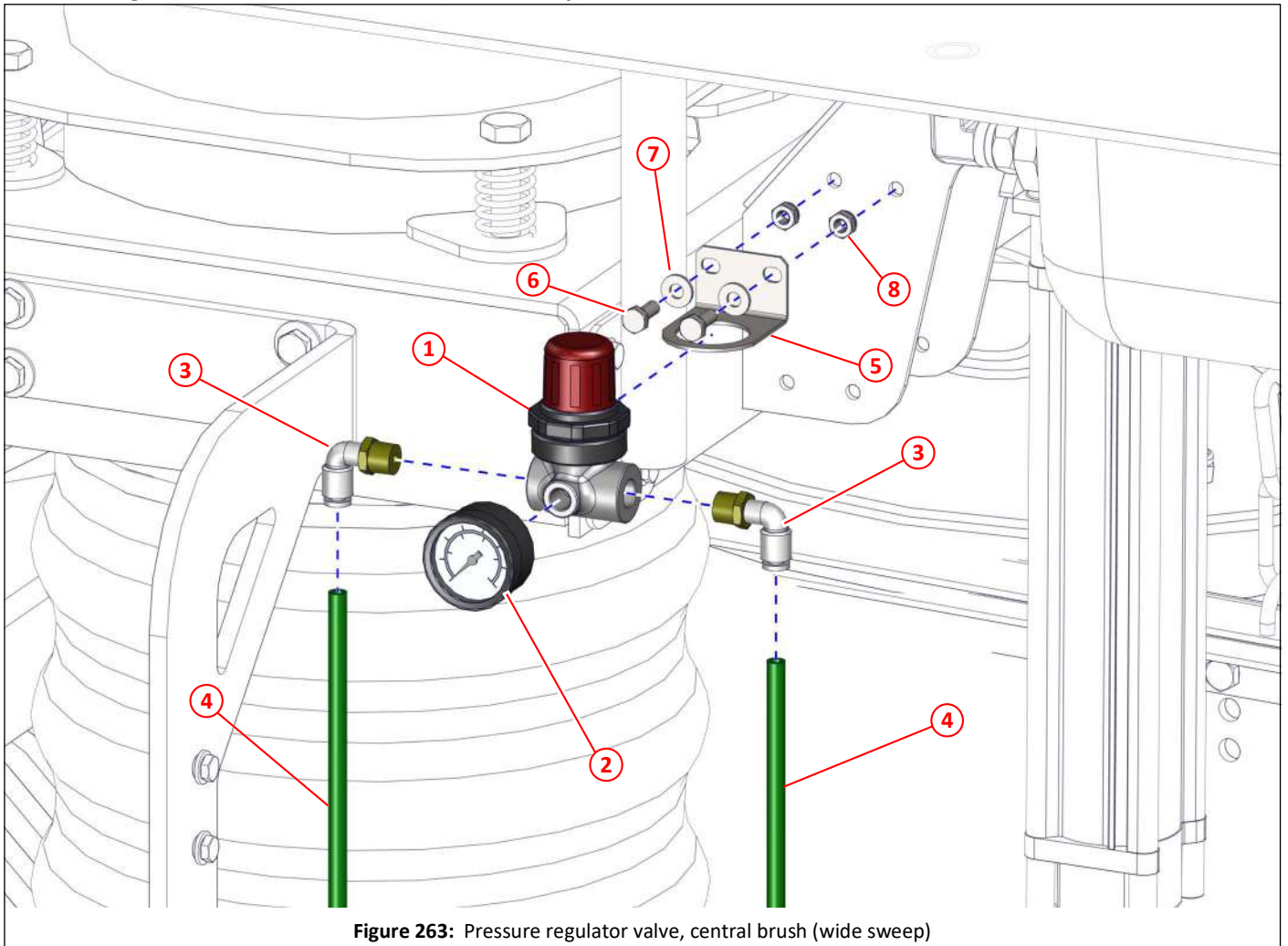
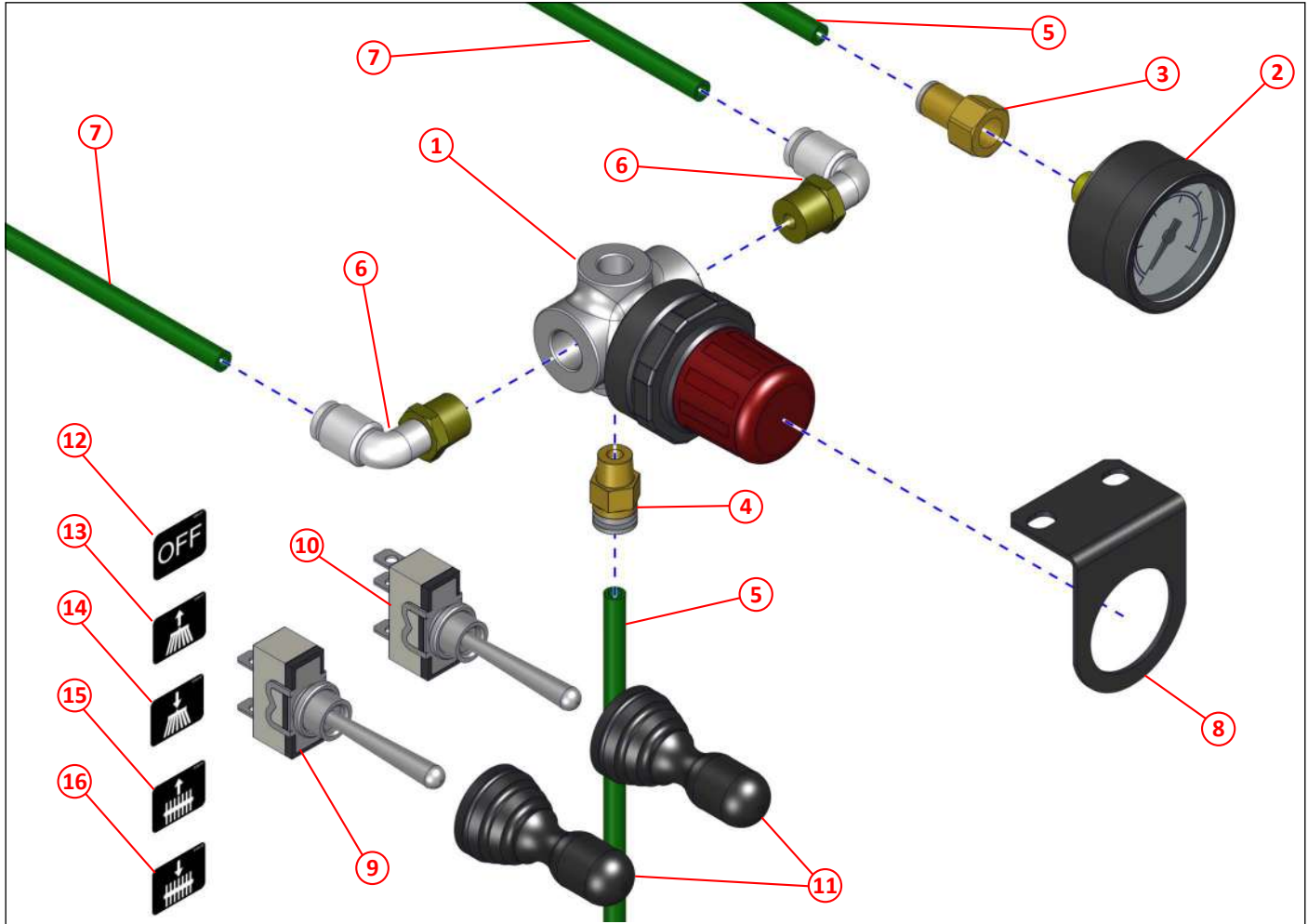

Figure 263: Pressure regulator valve, central brush (wide sweep)

Item	Part No	Qty	Description
①	023242	1	Pressure regulator, mini, 0.5 - 3.5 bar
②	023246		Gauge, pressure 0 - 10 bar
③	023203	2	Elbow, swivel, 1/4" BSP x 6 push in
④	024650	As req	Air pipe, green, ø6
⑤	023245	1	Bracket, mini pressure regulator
⑥	011001	2	Set screw M6 x 16
⑦	011090	2	Plain washer M6
⑧	011071	2	Nyloc nut M6



Pressure regulator valve side brush and switches for brush pressure (cab mounted)



**i** Typical items used in cab, actual items will depend on the specification of the sweeper and cab layout. Contact Scarab Parts Department with the works number of the sweeper for more information regarding these items.

Figure 264: Pressure regulator valve side brush and switches for brush pressure (cab mounted)

Item	Part No	Qty	Description
①	023242	1	Pressure regulator, mini, 0.5 - 3.5 bar
②	023246	1	Gauge, pressure 0 - 10 bar
③	024652	1	Union, female, 1/8" BSP x 6 push in
④	024643	1	Connector, straight, 1/8" BSP x 6 push in
⑤	024650	As req	Air pipe, green, ø6, connects items ③ and ④
⑥	023203	2	Elbow, swivel, 1/4" BSP x 6 push in
⑦	024650	As req	Air pipe, green, ø6
⑧	023245	1	Bracket, mini pressure regulator
⑨	037248	As req	Switch, toggle, ON/OFF/ON
⑩	037249	As req	Switch, toggle, ON/OFF
⑪	037247	As req	Rubber boot, toggle switch
⑫	038121	As req	Pressure OFF, label
⑬	038117	As req	Side brush pressure up, label
⑭	038118	As req	Side brush pressure down, label
⑮	038119	As req	Central brush (wide sweep) pressure up, label
⑯	038120	As req	Central brush (wide sweep) pressure down, label



Central brush (wide sweep), raise/lower/pressure

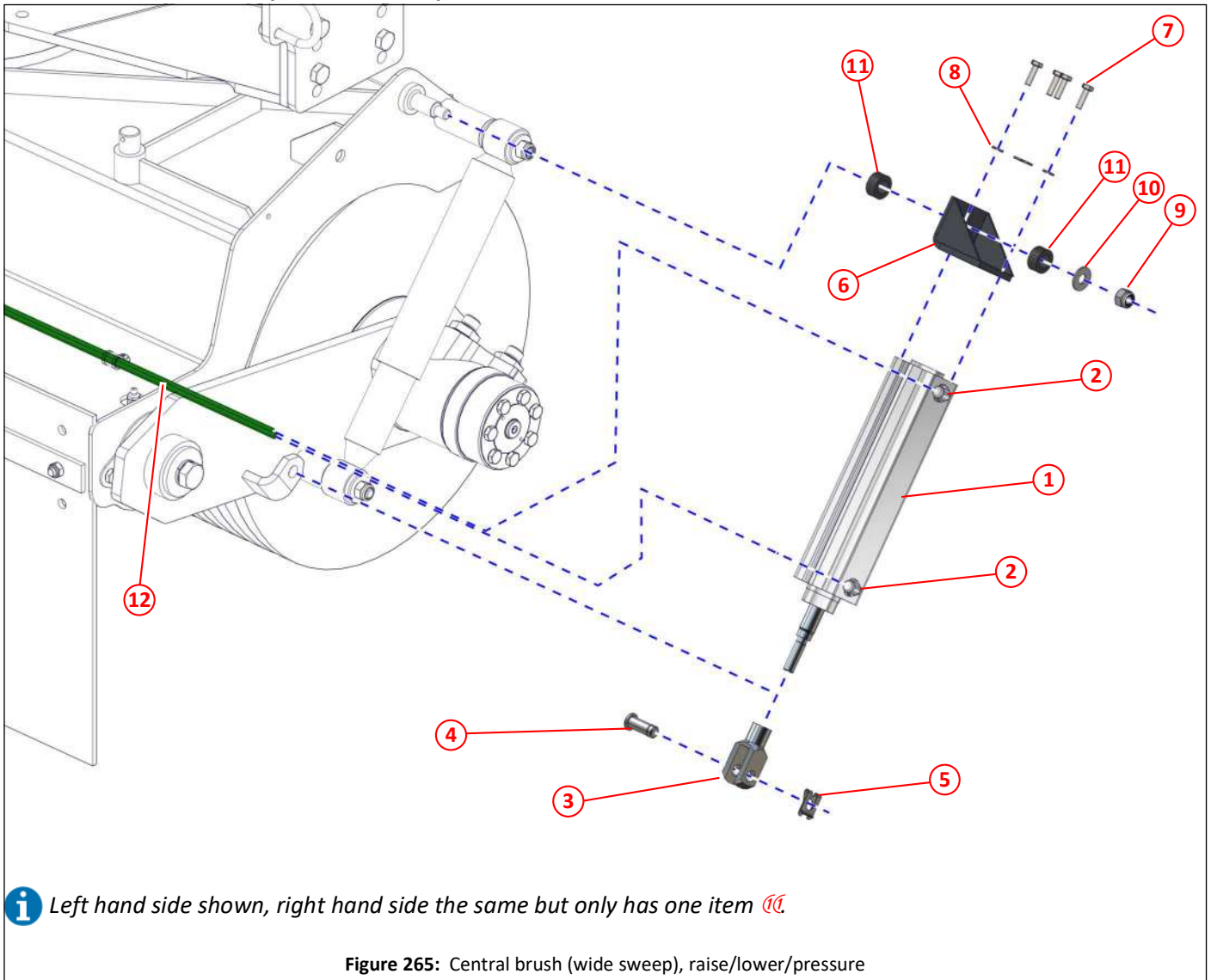

**i** Left hand side shown, right hand side the same but only has one item

Figure 265: Central brush (wide sweep), raise/lower/pressure

Item	Part No	Qty	Description
①	020602	1	Pneumatic cylinder 40 x 125
②	024646	2	Elbow, M/F, 1/4" BSP x ø6 push in
③	014469	1	Clevis M12
④	023270	1	Clevis pin ø12
⑤	023269	1	Safety fastener ø12
⑥	030532	1	Mounting bracket, pneumatic cylinder, central brush (wide sweep) raise/lower
⑦	011067	4	Set screw M6 x 20
⑧	011091	4	Spring washer M6
⑨	011075	1	Nyloc nut M10
⑩	011094	1	Plain washer M10
⑪	011000	2	Rubber bush, (hose 5/8")
⑫	024650	As req	Air pipe, green, ø6

Central brush (wide sweep), slewing

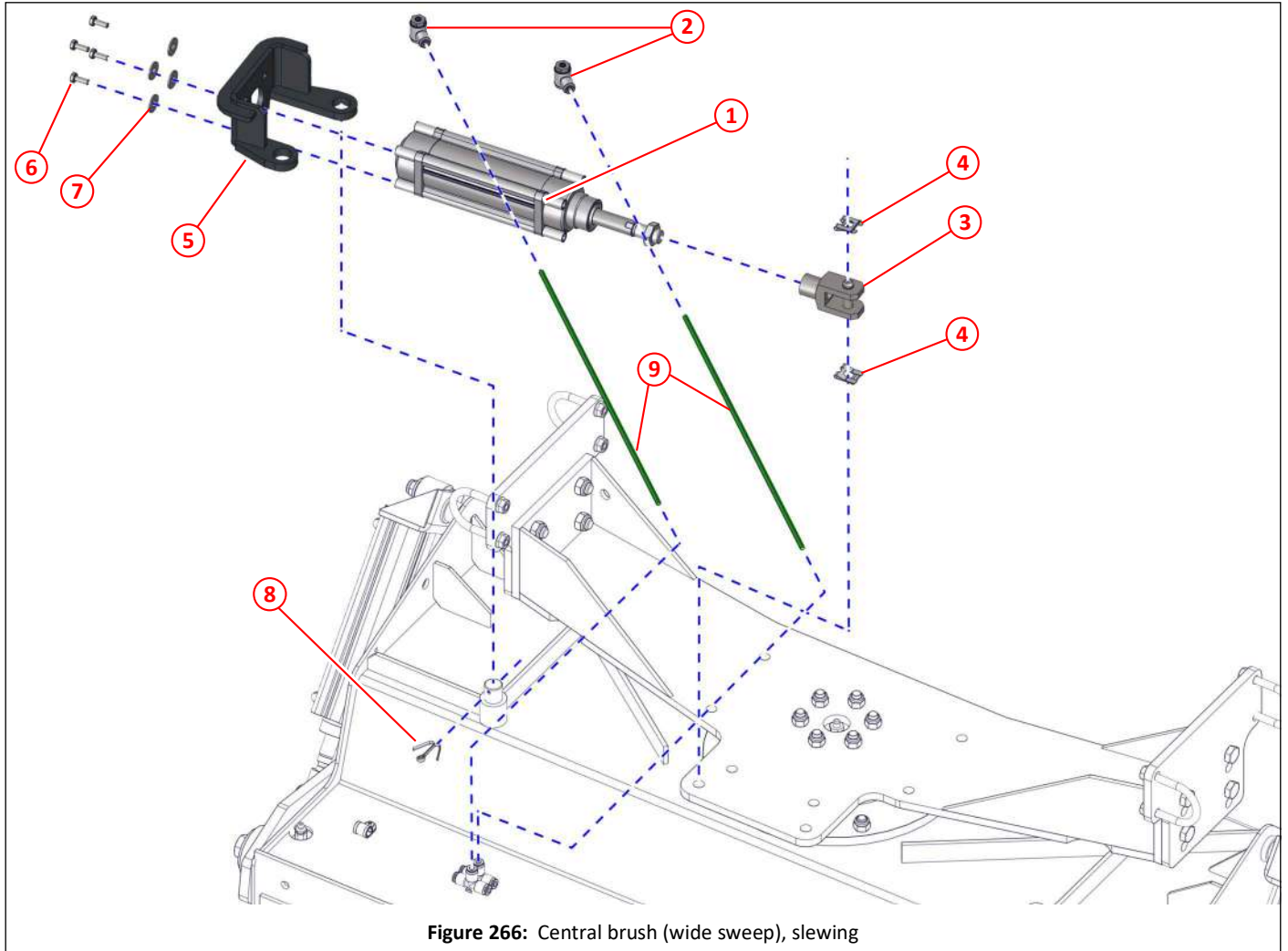
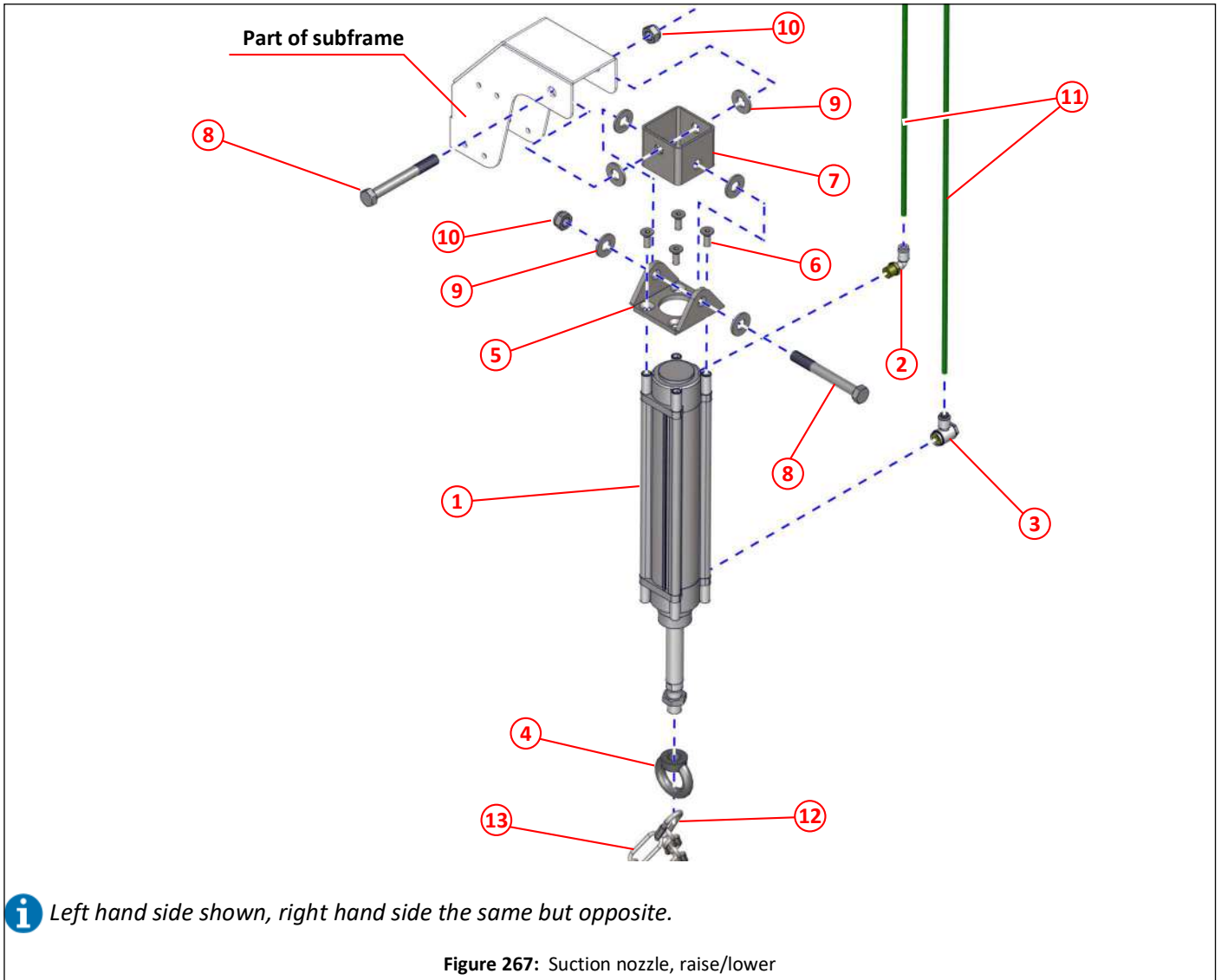

Figure 266: Central brush (wide sweep), slewing

Item	Part No	Qty	Description	
①	020767	1	Pneumatic cylinder 50 x 100	49
②	021158	2	Pneumatic flow regulator	
③	036621	1	Clevis, special	
④	023269	2	Safety fastener $\phi 12$	
⑤	036620	1	Mounting bracket, pneumatic cylinder, central brush (wide sweep) slewing	
⑥	011001	4	Set screw M6 X 16	
⑦	011092	4	Plain washer M6	
⑧	011122	1	Split pin $\frac{3}{16}'' \times 1\frac{1}{2}''$	
⑨	024650	As req	Air pipe, green, $\phi 6$	

Suction nozzle, raise/lower



**i** Left hand side shown, right hand side the same but opposite.

Figure 267: Suction nozzle, raise/lower

Item	Part No	Qty	Description
①	030772	1	Pneumatic cylinder 50 x 200
②	024646	1	Elbow, M/F, 1/4" BSP x ø6 push in
③	021158	2	Pneumatic flow regulator
④	032293	1	Ring nut, M16 x 1.5
⑤	030777	1	Pivot, pneumatic cylinder, suction nozzle raise/lower
⑥	000003	4	Screw, countersunk, socket M8 x 20
⑦	030776	1	Pivot block
⑧	011057	2	Bolt M12 x 100
⑨	011096	6	Plain washer M12
⑩	011077	2	Nyloc nut M12
⑪	024650	As req	Air pipe, green, ø6
⑫	010606	1	Carabiner
⑬	010525	As req	Chain, large link

Side brush, swing in/out

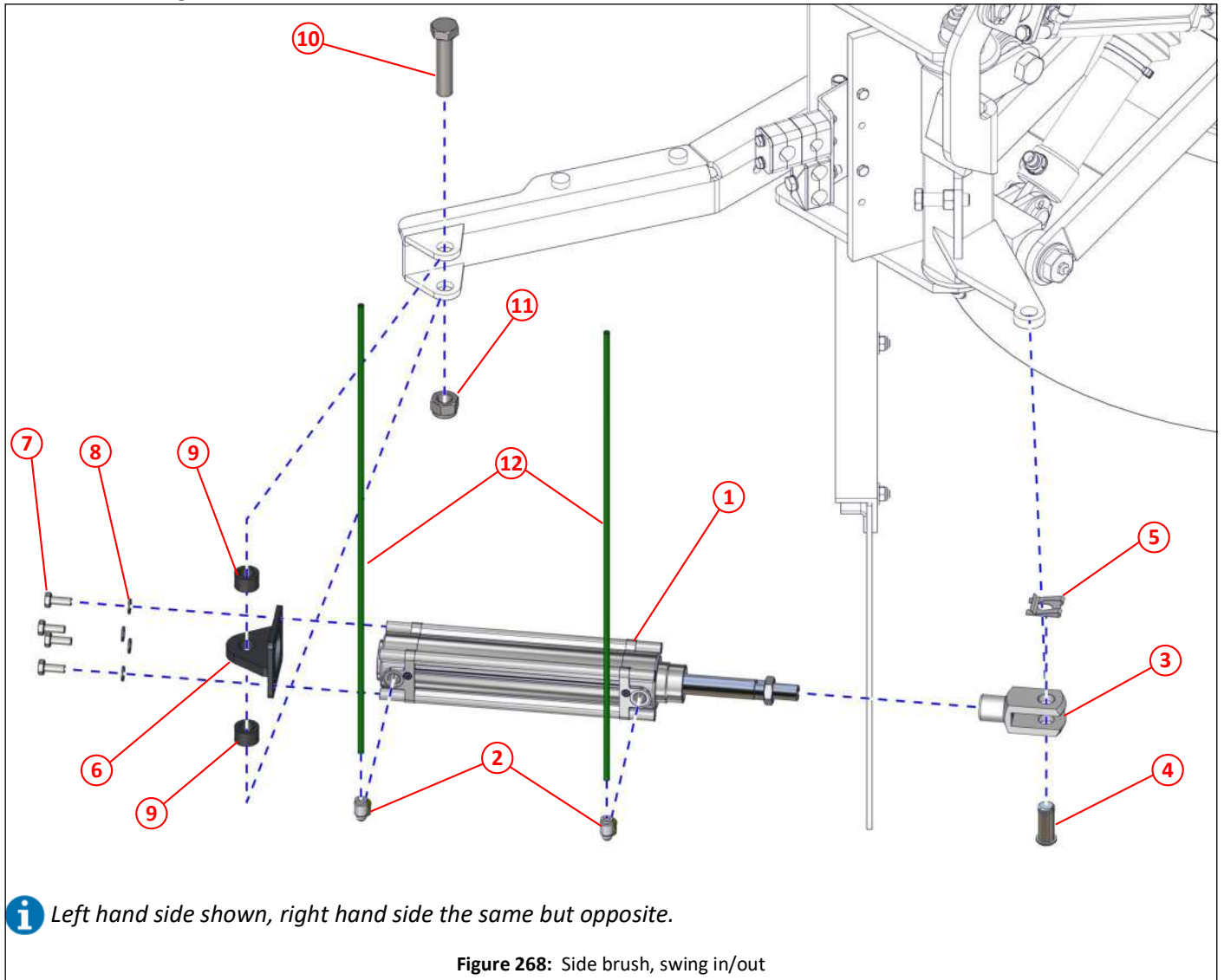

Item	Part No	Qty	Description	
①	020298	1	Pneumatic cylinder 50 x 160	29,38
②	024646	2	Elbow, M/F, 1/4" BSP x ø6 push in	
③	020299	1	Clevis M16 x 1.5	
④	022673	1	Clevis pin	
⑤	022674	1	Safety fastener ø16	
⑥	020534	1	Mounting bracket, pivot, pneumatic cylinder, side brush swing in/out	
⑦	011010	4	Set screw M8 x 20	
⑧	011093	4	Spring Washer M8	
⑨	011000	2	Rubber bush, (hose 5/8")	
⑩	011260	1	Bolt M16 x 70	
⑪	011060	1	Nyloc nut M16	
⑫	024650	As req	Air pipe, green, ø6	

Side brush, pressure

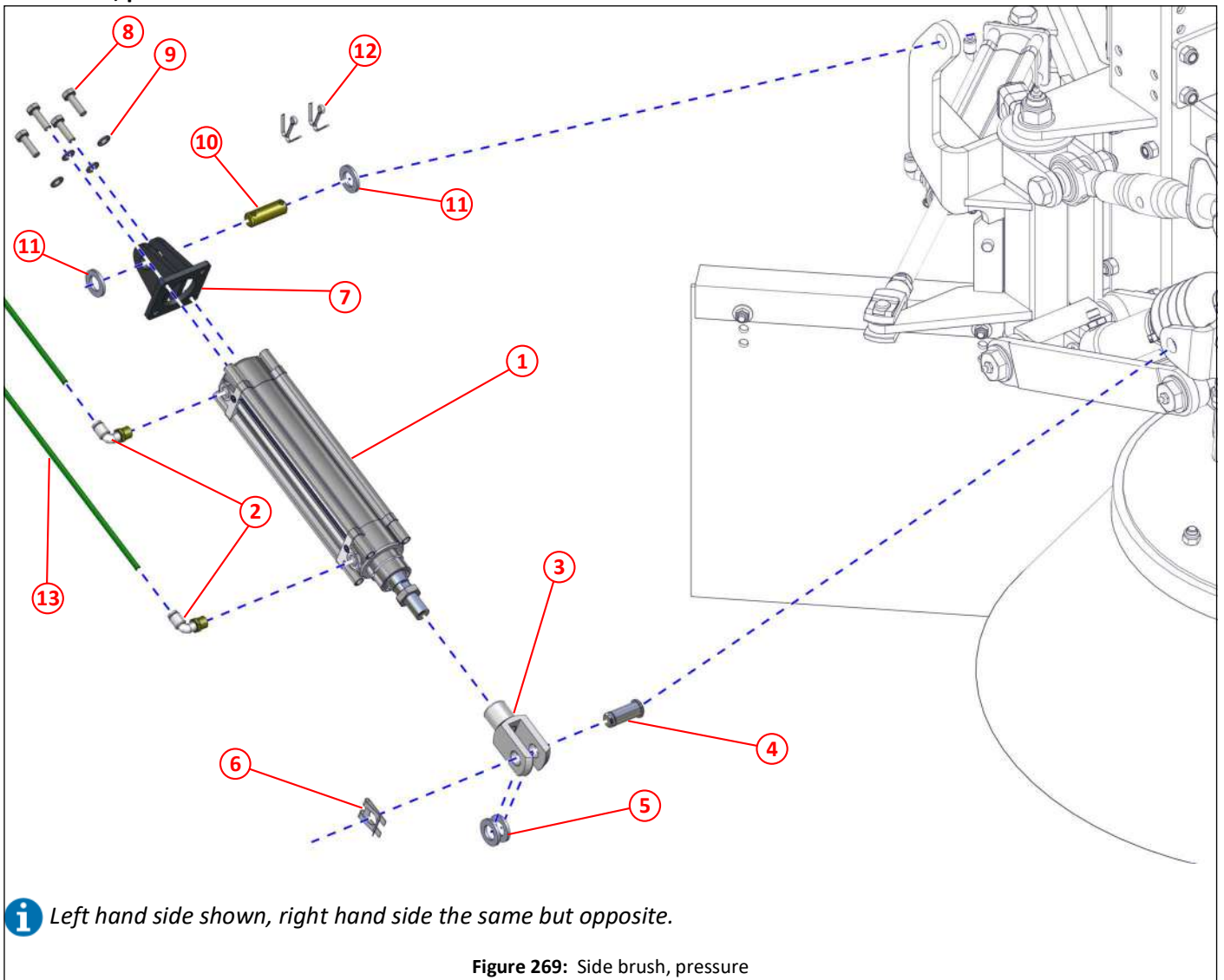

Item	Part No	Qty	Description
①	020298	1	Pneumatic cylinder 50 x 160
②	024646	2	Elbow, M/F, 1/4" BSP x ø6 push in
③	020299	1	Clevis M16 x 1.5
④	022673	1	Clevis pin
⑤	011135	2	Plain washer M16
⑥	022674	1	Safety fastener ø16
⑦	023122	1	Mounting bracket, pivot, pneumatic cylinder, side brush pressure
⑧	011011	4	Set screw M8 x 25
⑨	011093	4	Spring Washer M8
⑩	023123	1	Pin ø16 x 46
⑪	011135	2	Plain washer M16
⑫	011122	2	Split pin 3/16" x 1 1/2"
⑬	024650	As req	Air pipe, green, ø6



Auto blanking

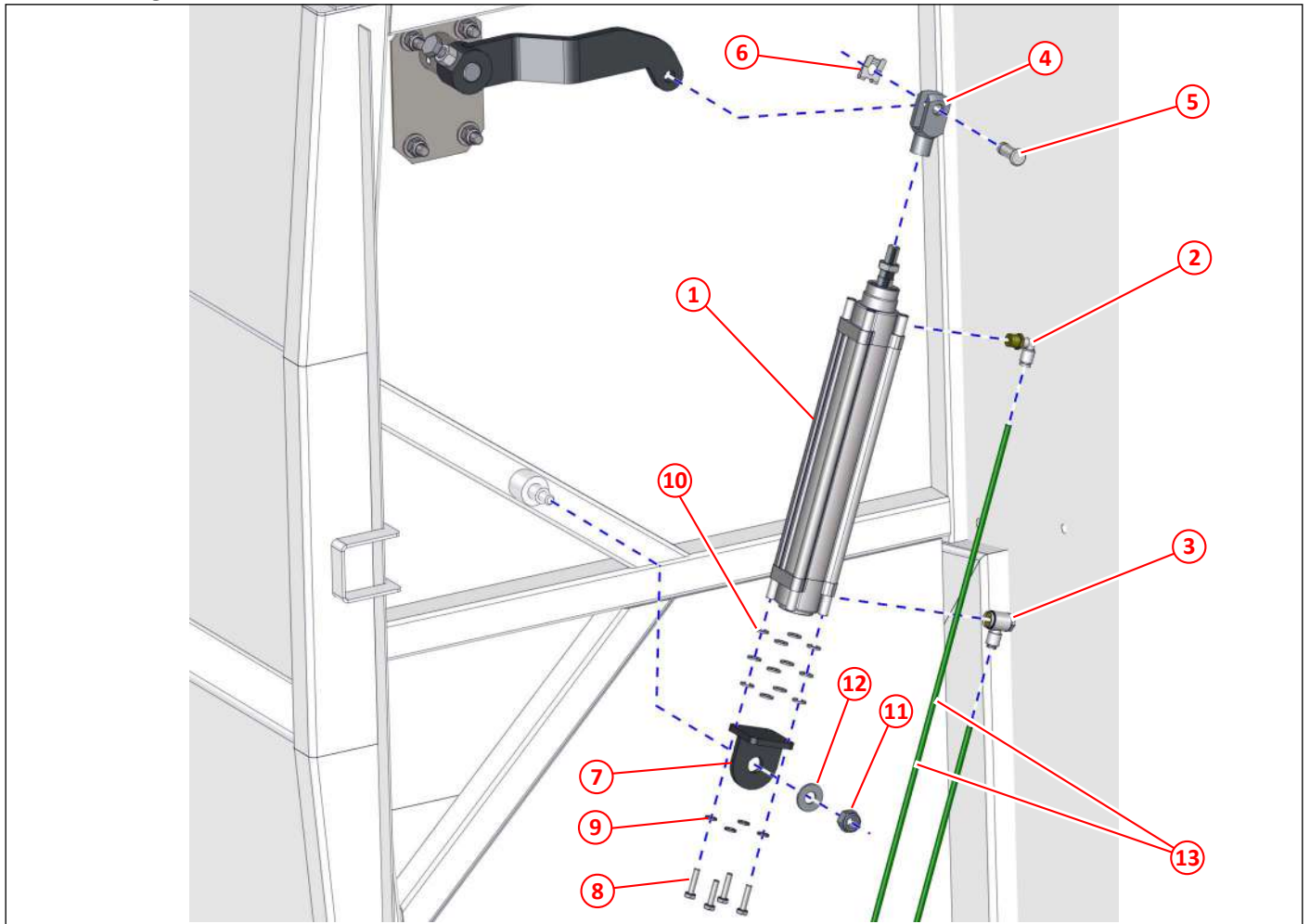

**i** Right hand side shown, left hand side the same but opposite.

Figure 270: Auto blanking, right hand side

Item	Part No	Qty	Description
①	021467		Pneumatic cylinder 40 x 200
②	024646	1	Elbow, M/F, 1/4" BSP x ø6 push in
③	021158	2	Pneumatic flow regulator
④	014469	1	Clevis M12
⑤	023270	1	Clevis pin ø12
⑥	023269	1	Safety fastener ø12
⑦	014457	1	Mounting bracket, pneumatic cylinder, auto blanking
⑧	011087	4	Set screw M6 x 25
⑨	011091	4	Spring washer M6
⑩	011090	12	Plain washer M6
⑪	000275	1	Nyloc nut M12, stainless steel
⑫	000277	1	Plain washer M12, stainless steel
⑬	024650	As req	Air pipe, green, ø6



Auxiliary brush, raise/lower

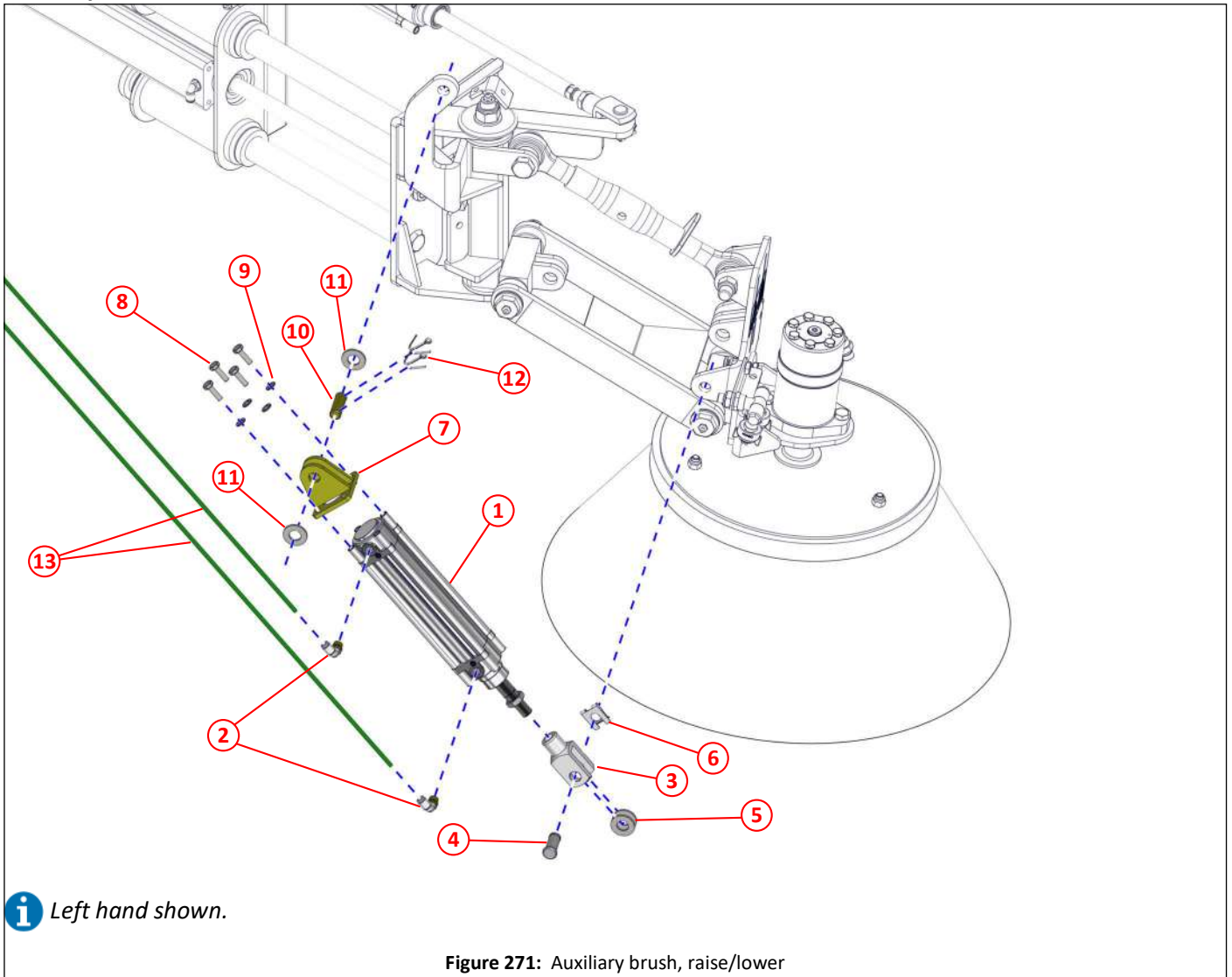

**i** Left hand shown.

Figure 271: Auxiliary brush, raise/lower

Item	Part No	Qty	Description
①	020298	1	Pneumatic cylinder 50 x 160
②	024646	2	Elbow, M/F, 1/4" BSP x ø6 push in
③	020299	1	Clevis M16 x 1.5
④	022673	1	Clevis pin
⑤	011135	2	Plain washer M16
⑥	022674	1	Safety fastener ø16
⑦	023122	1	Mounting bracket, pneumatic cylinder, auxiliary brush raise/lower
⑧	011011	4	Set screw M8 x 25
⑨	011093	4	Spring washer M8
⑩	023123	1	Pin ø16 x 46
⑪	011135	2	Plain washer M16
⑫	011122	2	Split pin 3/16" x 1 1/2"
⑬	024650	As req	Air pipe, green, ø6

Auxiliary brush, left hand, swing in/out

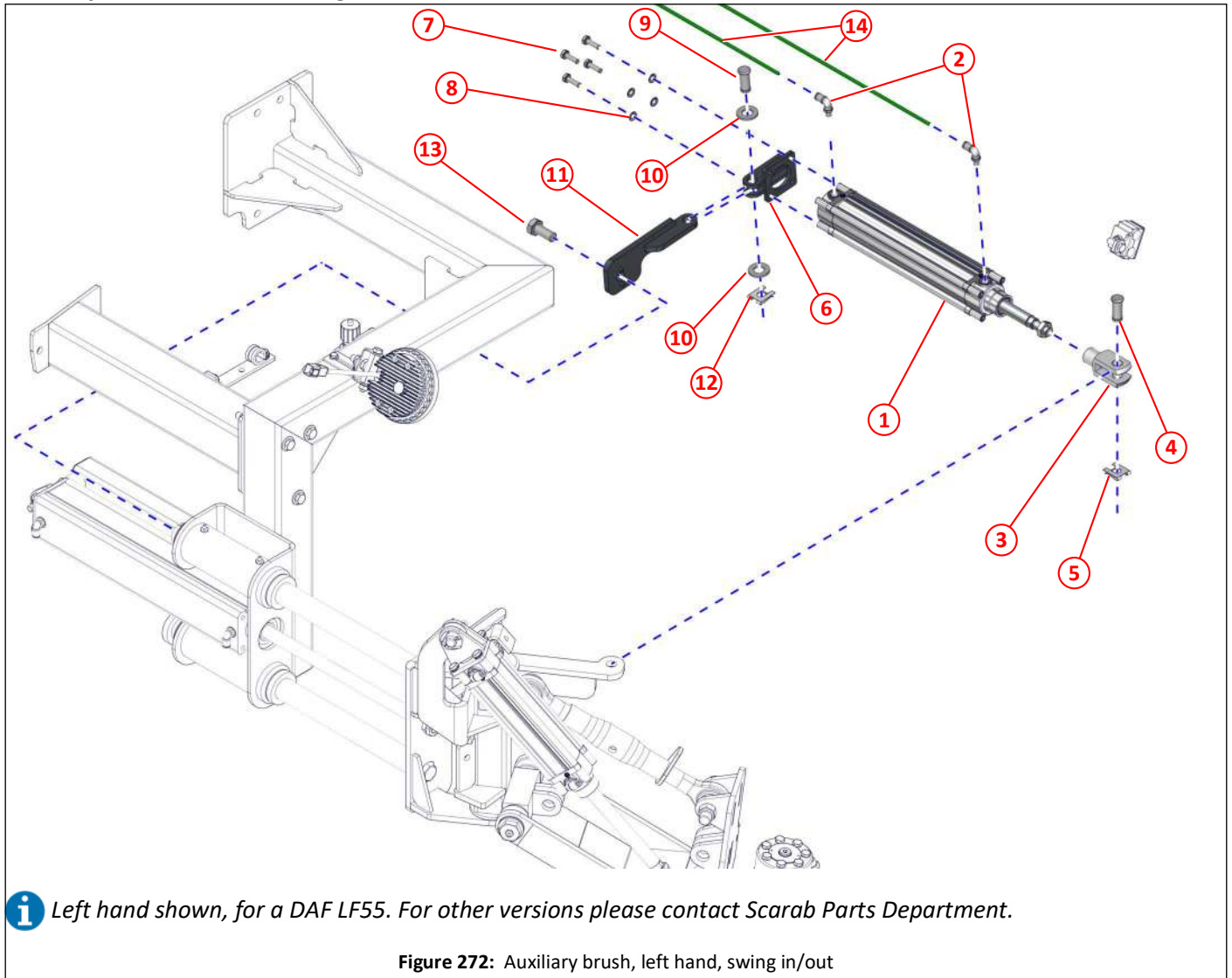

**i** Left hand shown, for a DAF LF55. For other versions please contact Scarab Parts Department.

Figure 272: Auxiliary brush, left hand, swing in/out

Item	Part No	Qty	Description
①	021521	1	Pneumatic cylinder 50 x 160
②	024646	2	Elbow, M/F, 1/4" BSP x ø6 push in
③	020299	1	Clevis M16 x 1.5
④	022673	1	Clevis pin
⑤	022674	1	Safety fastener ø16
⑥	030860	1	Mounting bracket, left hand, pneumatic cylinder, auxiliary brush, swing in/out
⑦	011011	4	Set screw M8 x 25
⑧	011093	4	Spring washer M8
⑨	022673	1	Clevis pin
⑩	011135	2	Plain washer M16
⑪	022674	1	Safety fastener ø16
⑫	042207	1	Auxiliary brush push link
⑬	011141	1	Bolt M16 x 35
⑭	024650	As req	Air pipe, green, ø6

Auxiliary brush, extend/retract

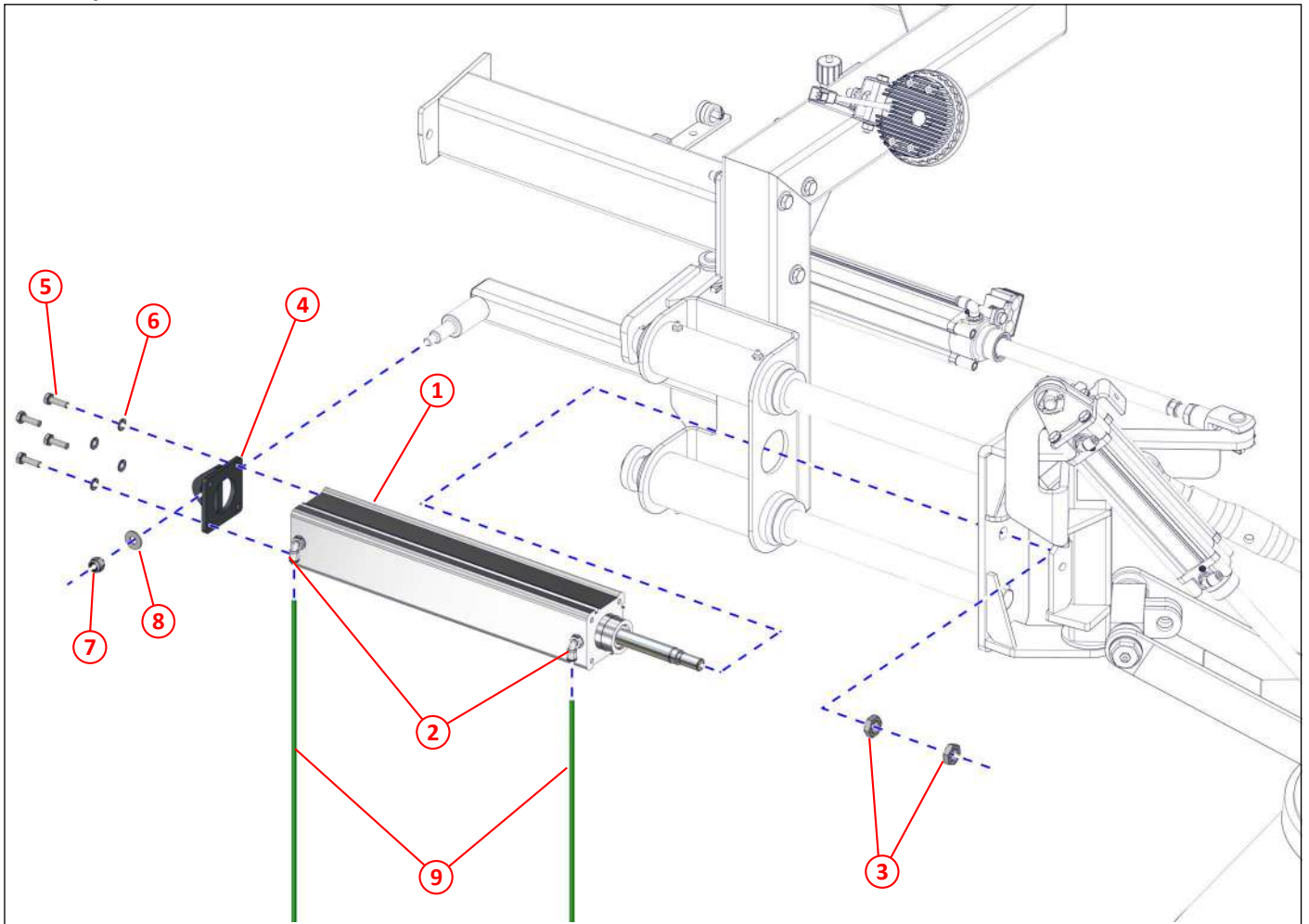

**i** Left hand shown, for a DAF LF55. For other versions please contact Scarab Parts Department.

Figure 273: Auxiliary brush, extend/retract

Item	Part No	Qty	Description
①	026396	1	Pneumatic cylinder 63 x 320
②	024646	2	Elbow, M/F, 1/4" BSP x ø6 push in
③	000138	2	Lock nut M16 x 1.5
④	030859	1	Mounting bracket, pneumatic cylinder, auxiliary brush extend/retract
⑤	011011	4	Set screw M8 x 25
⑥	011093	4	Spring washer M8
⑦	011075	1	Nyloc nut M10
⑧	011094	1	Plain washer M10
⑨	024650	As req	Air pipe, green, ø6

Hopper safety prop, kicker

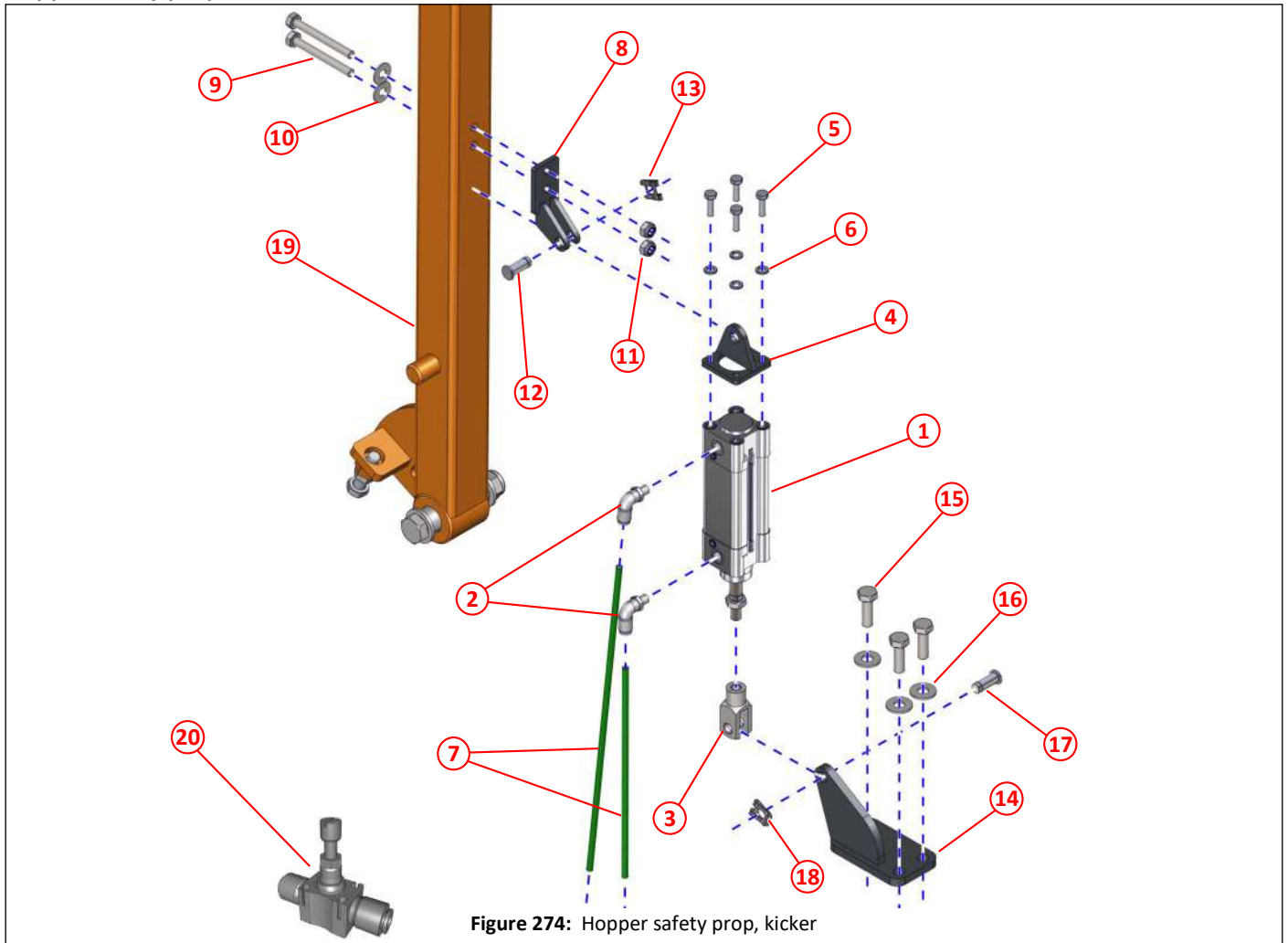



Figure 274: Hopper safety prop, kicker

Item	Part No	Qty	Description	
①	043175	1	Pneumatic cylinder, prop kicker	365,366,368
②	024646	2	Elbow, M/F, 1/4" BSP x ø6 push in	
③	020291	1	Clevis, M10 x 1.25	
④	043174	1	Mount, pneumatic cylinder, prop kicker	
⑤	000252	4	Set screw M6 x 20, stainless steel	
⑥	000255	4	Spring washer M6, stainless steel	
⑦	024650	As req	Air pipe, green, ø6	
⑧	043390	1	Bracket, prop kicker	
⑨	011018	2	Bolt M8 x 70	
⑩	011092	2	Plain washer M8	
⑪	011073	2	Nyloc nut M8	
⑫	026163	1	Clevis pin	
⑬	026164	1	Retaining clip	
⑭	043364	1	Floor mount, prop kicker	
⑮	011032	3	Set screw M10 x 30	
⑯	011094	3	Plain washer M10	
⑰	026163	1	Clevis pin	
⑱	026164	1	Retaining clip	
⑲	043391	1	Hopper safety prop	365,366
⑳	006062	2	In-line flow control valve (Mounted on subframe below hopper prop)	

# Electrical

<i>Description</i>	<i>Page</i>
Electrical components in the cab	318
Main control panel	318
Auxiliary control panel (door pod)	319
Hopper controller remote	320
Display screen, operator, programmed	320
CR2012 cabinet module, node	320
Beacon switch	321
Sounder, main control panel	321
Camera monitor	321
Camera splitter	322
Fuses and relays, cab	322
Node cabinet	323
Nodes	324
Relays	324
Power connection link	324
Power post	325
Switch, gantry work light	325
Fuses, Nodes	326
Battery junction box	327
Lights, lamps and cameras	328
Work light	328
LED marker rear light	328
Beacon	328
LED beacon	329
Cameras	329
Wiring looms and cables	330
Switches	330
Sensors	331
Fuses	331
Relays	331

 *Please be aware that the following pages have both 24v and 12v components. Please ensure you select the correct voltage part for your vehicle.*



Main control panel

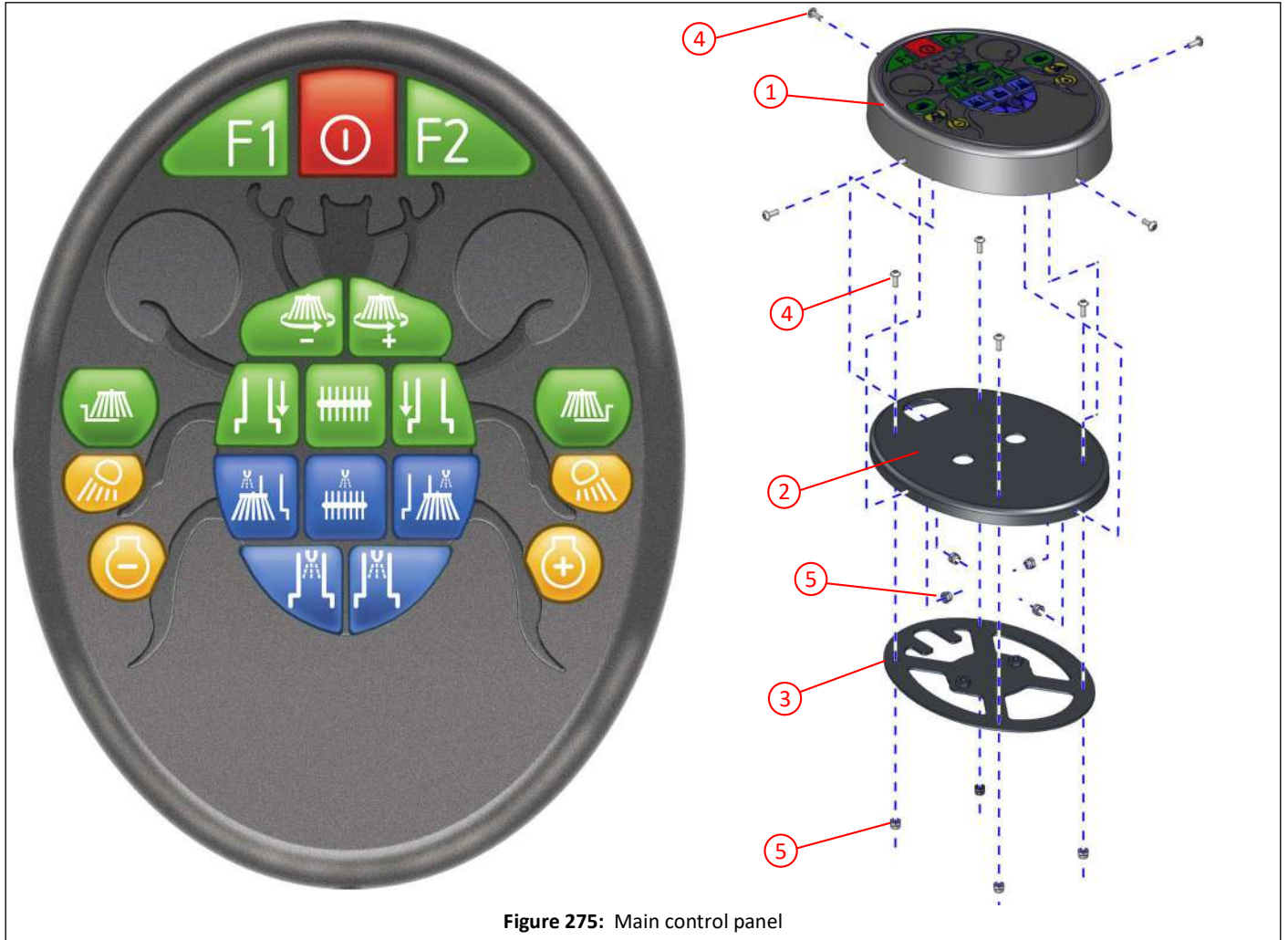

Figure 275: Main control panel

Item	Part No	Qty	Description	
①	037602	1	Main control panel, fascia and keypad	443
②	037053	1	Backplate, main control panel	
③	037055	1	Spider plate, main control panel	
④	000304	8	Socket button head M4 x 10, black	
⑤	000134	8	Nyloc nut M4	
NI	036912	1	Loom, main control panel	330
NI	036914	1	Loom, power/CAN, main control panel	330



Auxiliary control panel (door pod)

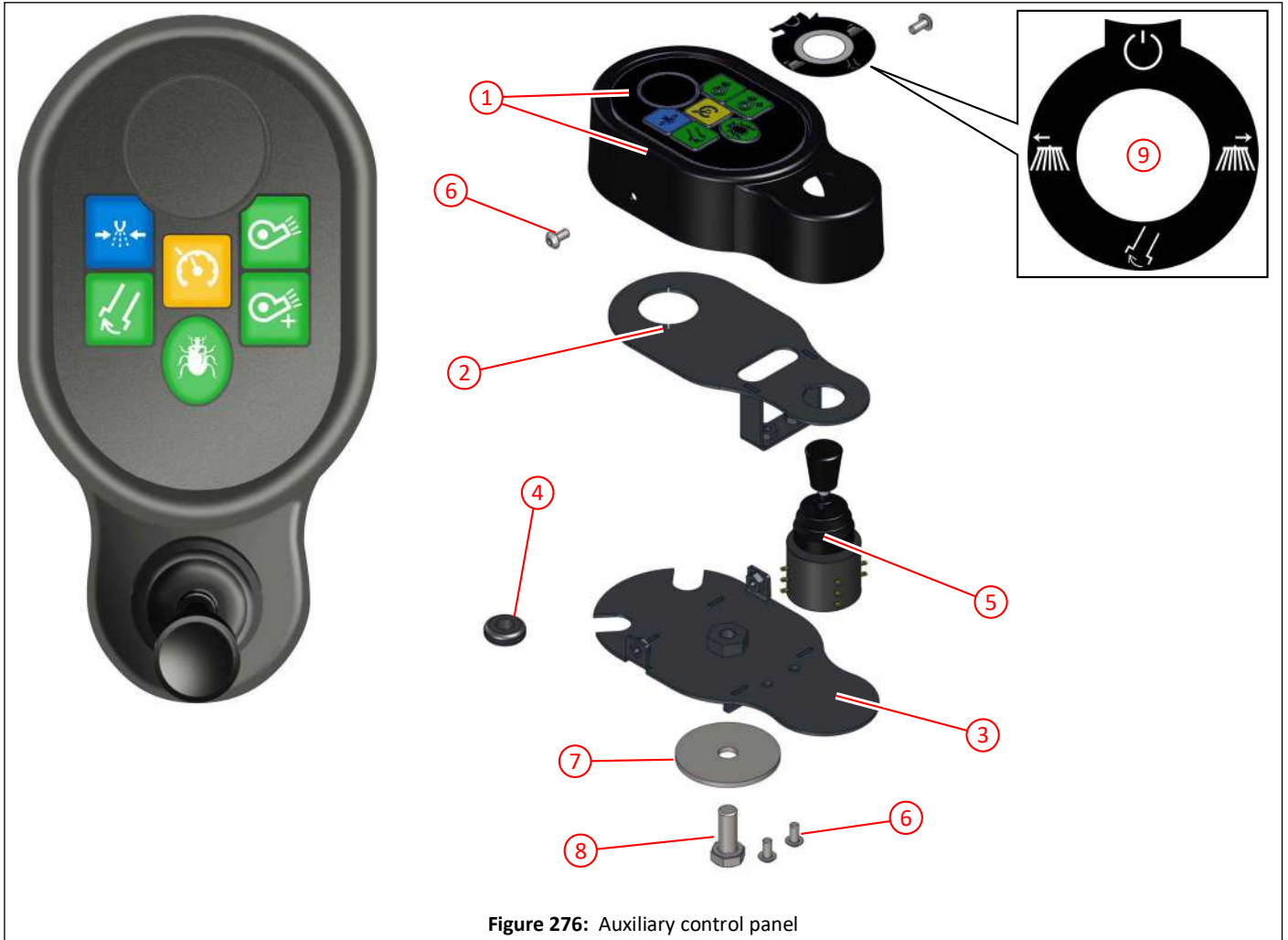

Figure 276: Auxiliary control panel

Item	Part No	Qty	Description	
①	037608	1	Auxiliary control panel (door pod), fascia and keypad	445
②	037057	1	Support plate, auxiliary control panel (door pod)	
③	037058	1	Backplate, auxiliary control panel (door pod), universal	
④	046259	1	Blind grommet	
⑤	036873	1	Ergo joystick	
⑥	000380	4	Socket button head M5 x 10, black	
⑦	037064	1	Lock washer, auxiliary control panel (door pod)	
⑧	011031	1	Set screw M10 x 25	
⑨	039545	1	Label, ergo joystick	
NI	036913	1	Loom, auxiliary control panel (door pod)	330
NI	036915	1	Loom, power/CAN, auxiliary control panel (door pod)	330

Hopper controller remote



Figure 277: Hopper controller remote

Item	Part No	Qty	Description	
①	043688	1	Hopper controller (PXL)	
②	043691	1	Holster, hopper controller (PXL)	
	044294	1	Hopper controller complete with holster, includes items ① and ②	
NI	037047	1	Loom, hopper controller	330

Display screen, operator, programmed

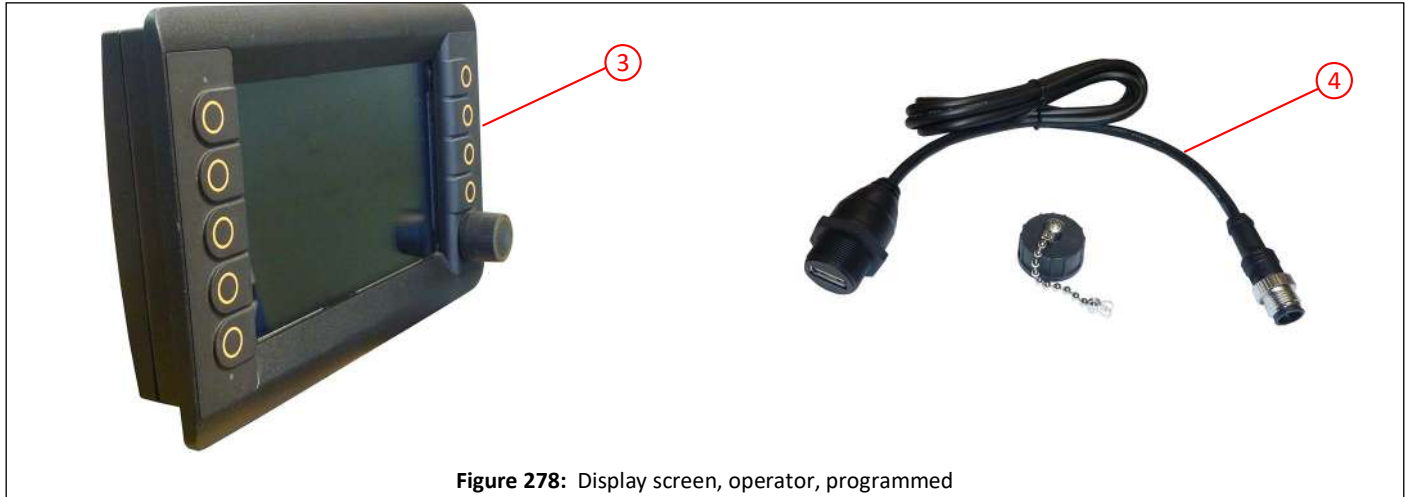

Figure 278: Display screen, operator, programmed

Item	Part No	Qty	Description	
③	051274	1	Display screen, operator, CR1084, programmed	442,443
④	039672	1	Cable, M12 to USB	330
NI	040349	1	Loom, display screen	330

CR2012 cabinet module, node

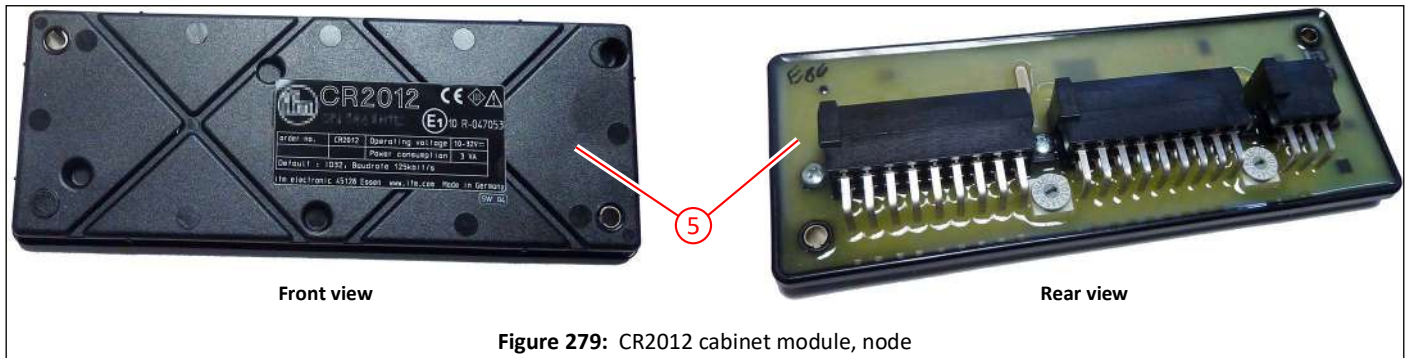

Figure 279: CR2012 cabinet module, node

Item	Part No	Qty	Description	
⑤	036799	3	CR2012 cabinet module, node, behind dash	
NI	038013	1	Loom, cab	330,448

**Beacon switch**



Figure 280: Beacon switch

Item	Part No	Qty	Description	
①	042049 *	1	Beacon switch, DAF	330
②	038543 *	1	Beacon switch, Renault	330
NI	038013	1	Loom, cab	330

\*. Switches for other chassis manufacturers please contact Scarab Parts Department.

**Sounder, main control panel**



Figure 281: Sounder, main control panel

Item	Part No	Qty	Description	
③	037048	1	Sounder	
NI	036912	1	Loom, main control panel	330

**Camera monitor**



Figure 282: Camera monitor

Item	Part No	Qty	Description	
④	040717	1	Camera monitor	

Camera splitter

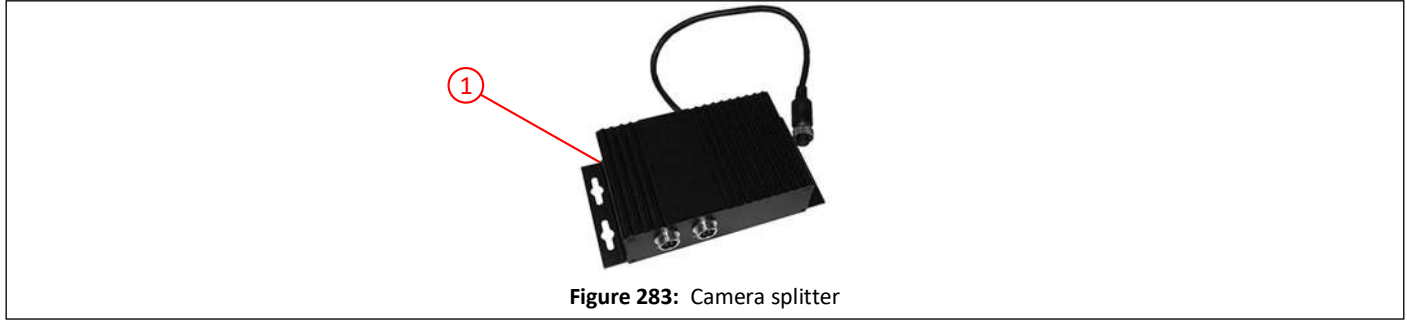

Figure 283: Camera splitter

Item	Part No	Qty	Description
③	041534	1	Camera splitter

Fuses and relays, cab

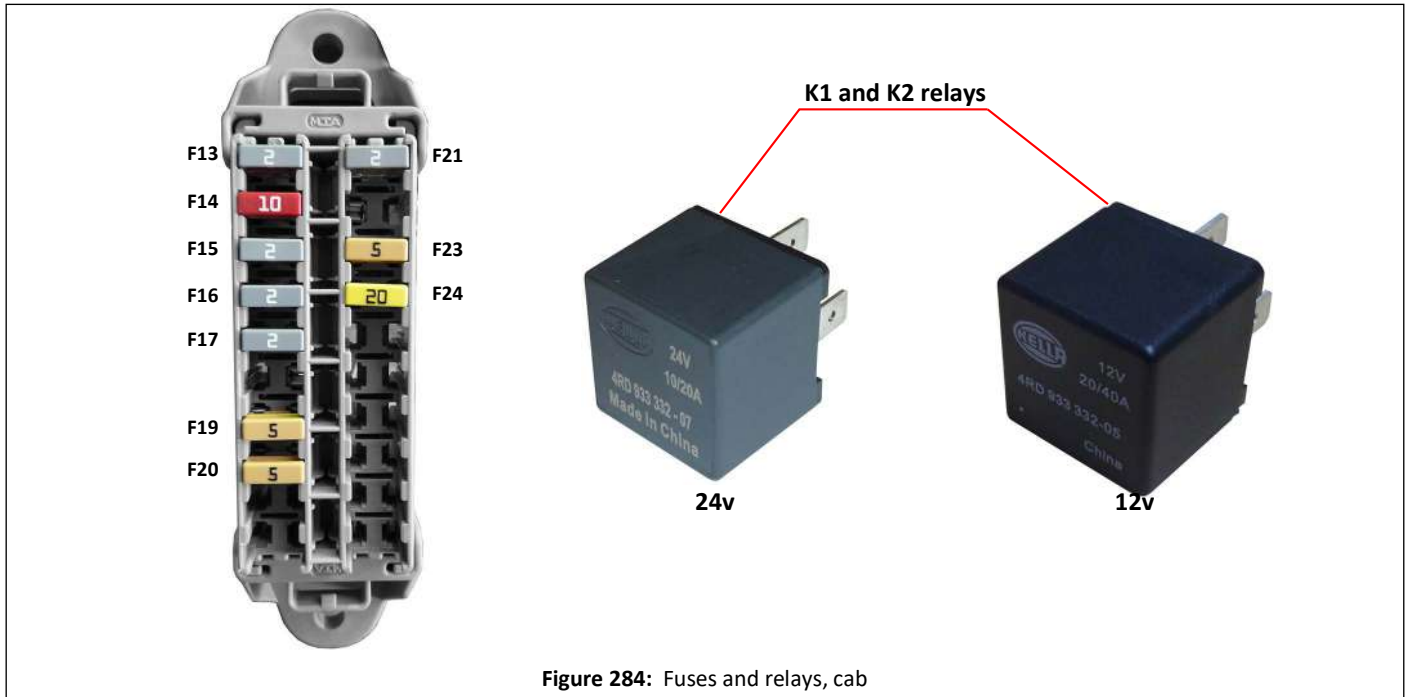

Figure 284: Fuses and relays, cab

Item	Part No	Qty	Description
F13	004495	1	Fuse, mini blade, 2 Amp, Vehicle ignition
F14	004393	1	Fuse, mini blade, 10 Amp, Scarab, Ignition+
F15	004495	1	Fuse, mini blade, 2 Amp, Node 2, LCD Monitor, Ignition+
F16	004495	1	Fuse, mini blade, 2 Amp, Node 0, Auxiliary Control Panel, Ignition+
F17	004495	1	Fuse, mini blade, 2 Amp, Node 1, Main Control Panel, Ignition+
F19	004391	1	Fuse, mini blade, 5 Amp, Body Builder Plug, Ignition+
F20	004391	1	Fuse, mini blade, 5 Amp, Hopper Remote Control Unit, Ignition+
F21	004495	1	Fuse, mini blade, 2 Amp, Node 2, LCD Monitor, Battery+
F23	004391	1	Fuse, mini blade, 5 Amp, Body Builder Plug, Battery+
F24	004395	1	Fuse, mini blade, 20 Amp, Beacon(s)
K1	014718	1	Relay, 10/20 Amp, Beacon(s), <b>24v</b>
K1	011768	1	Relay, 10/20 Amp, Beacon(s), <b>12v</b>
K2	014718	1	Relay, 10/20 Amp, Ignition, <b>24v</b>
K2	011768	1	Relay, 10/20 Amp, Ignition, <b>12v</b>

**i** The above items are located on the cab loom and will be behind the dash on the vehicle.



Node cabinet

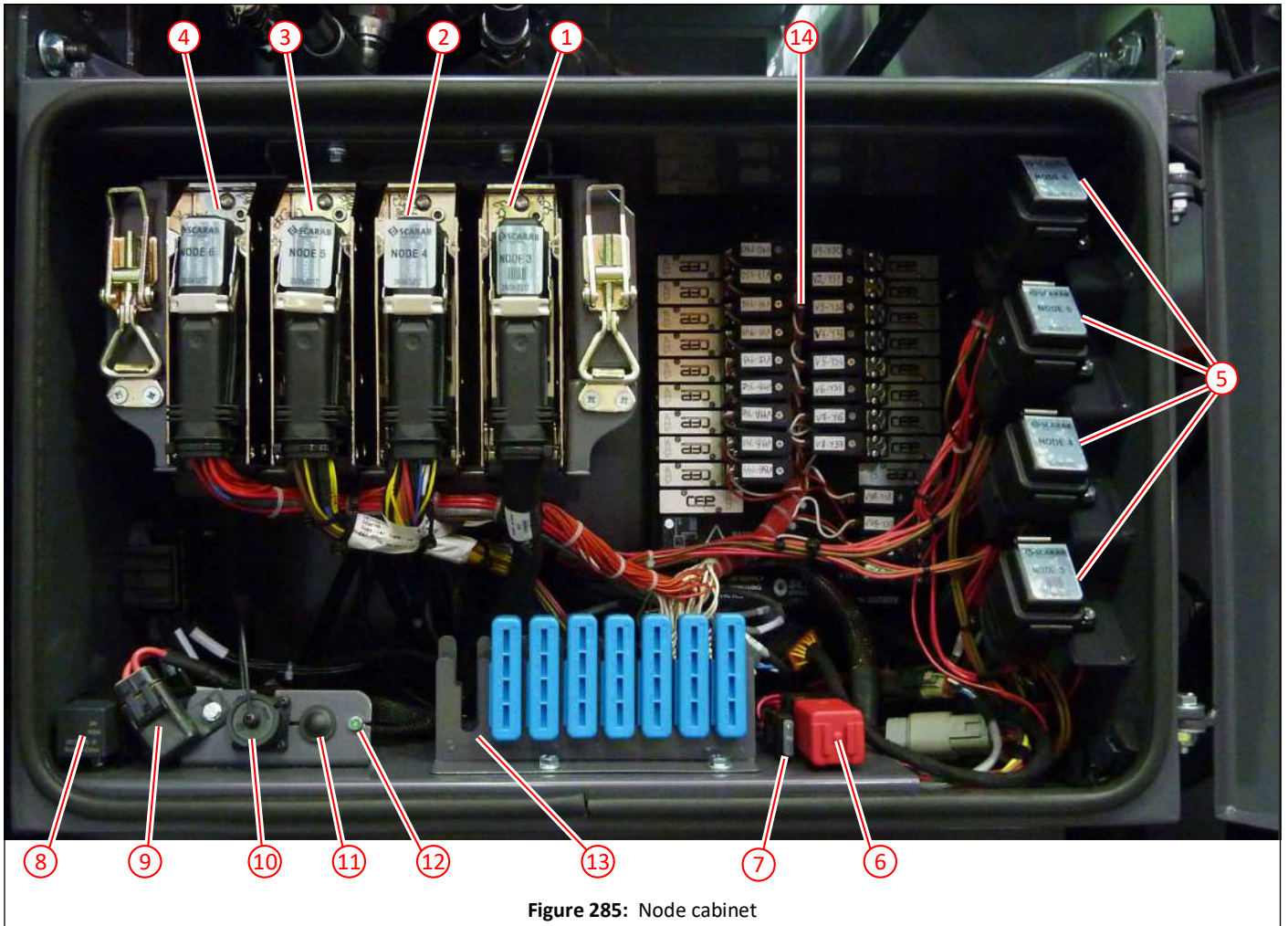

Figure 285: Node cabinet

Item	Part No	Qty	Description	
①	042342	1	Node 3, CR0505, programmed	324
②	042336	1	Node 4, CR0020, programmed	324
③	042336	1	Node 5, CR0020, programmed	324
④	042336	1	Node 6, CR0020, programmed	324
⑤			Fuse box, Node 3, Node 4, Node 5 and Node 6, part of the node looms	326,330
⑥	043720	1	Timer relay, engine work light, K7, holder part of engine work light loom, <b>24v</b>	324,331
⑥	045511	1	Timer relay, engine work light, K7, holder part of engine work light loom, <b>12v</b>	324,331
⑦	004485	1	Fuse, blade, 2 Amp, engine work light, F33, holder part of engine work light loom	331
⑧	014718	1	Relay, fuel pump, K6, holder part of engine loom, <b>24v</b>	324,330,331
⑧	011768	1	Relay, fuel pump, K6, holder part of engine loom, <b>12v</b>	324,330,331
⑨	014292	1	Fuse, blade, 30 Amp, engine ECU, F29, holder part of engine loom	331
⑩			Engine diagnostic plug, part of Node 3 loom	330
⑪			Engine diagnostic switch, part of Node 3 loom	330
⑫	004564		Engine diagnostic lamp, <b>24v</b>	
⑬	004565		Engine diagnostic lamp, <b>12v</b>	
⑭	037994	1	Splice saver rack	
⑮			Pneumatics board	292,294
NI	036844	2	Power connection link, behind fuse boxes and behind fuel pump relay	324
NI	036843	1	Power post, M6, red, behind fuse boxes	325
NI	004489	1	Rubber boot, red, for power post	325
NI	038223	1	Switch, gantry work light, green, on side of node cabinet, behind fuse boxes	325

Nodes

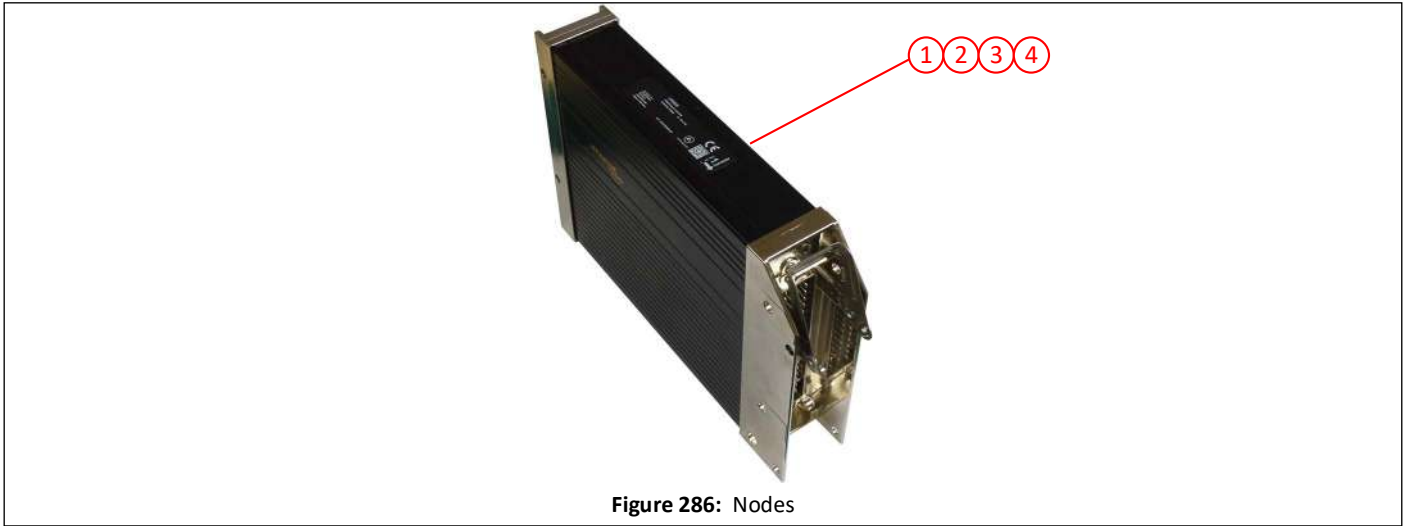

Figure 286: Nodes

Item	Part No	Qty	Description	
①	042342	1	Node 3, CR0505, programmed	323
②	042336	1	Node 4, CR0020, programmed	323
③	042336	1	Node 5, CR0020, programmed	323
④	042336	1	Node 6, CR0020, programmed	323

Relays

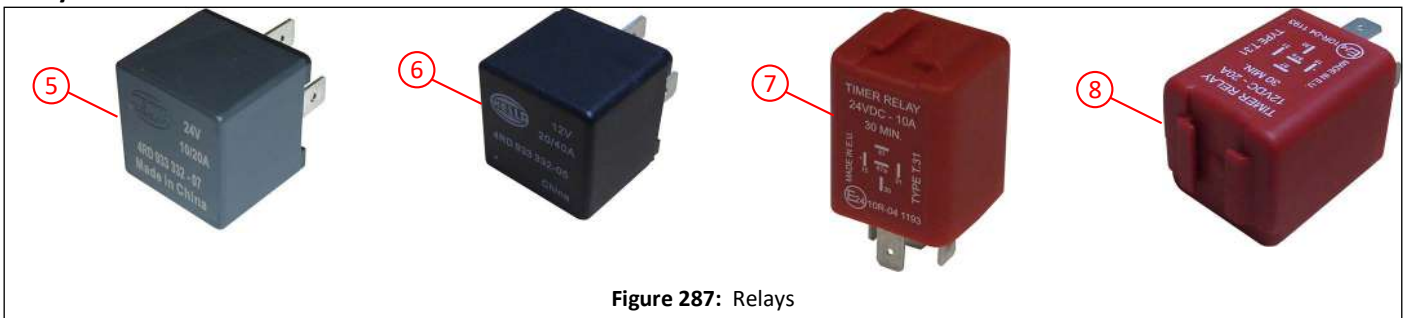

Figure 287: Relays

Item	Part No	Qty	Description	
⑤	014718	1	Relay, fuel pump, K6, <b>24v</b>	323,331
⑥	011768	1	Relay, fuel pump, K6, <b>12v</b>	323,331
⑦	043720	1	Timer relay, gantry work light, K7, <b>24v</b>	323,331
⑧	044511	1	Timer relay, gantry work light, K7, <b>12v</b>	323,331

Power connection link

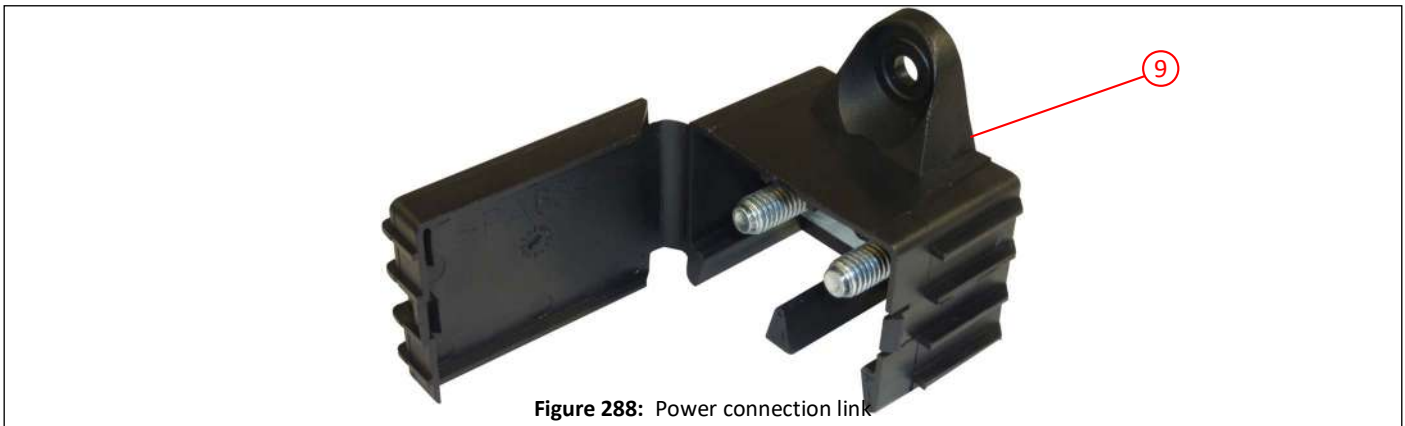

Figure 288: Power connection link

Item	Part No	Qty	Description	
⑨	036844	1	Power connection link, supplied with Nyloc nuts	323



Power post

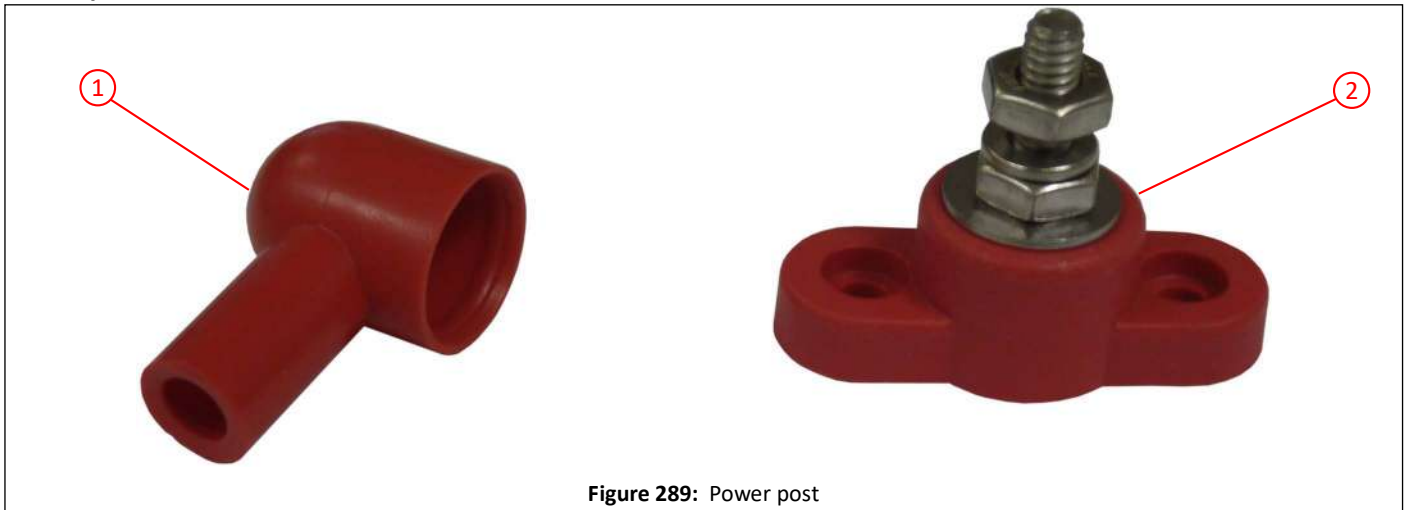

Figure 289: Power post

Item	Part No	Qty	Description	
①	004489	1	Rubber boot, power post, red	323
②	036843	1	Power post, red	323
NI	000429	1	Nyloc nut, 1/4" UNC, plated, to be used on power post instead of top half nut	

Switch, gantry work light



Figure 290: Switch, gantry work light

Item	Part No	Qty	Description	
③	038223	1	Switch, gantry work light, green	323
NI	043719	1	Loom, gantry work light	330

Fuses, Nodes

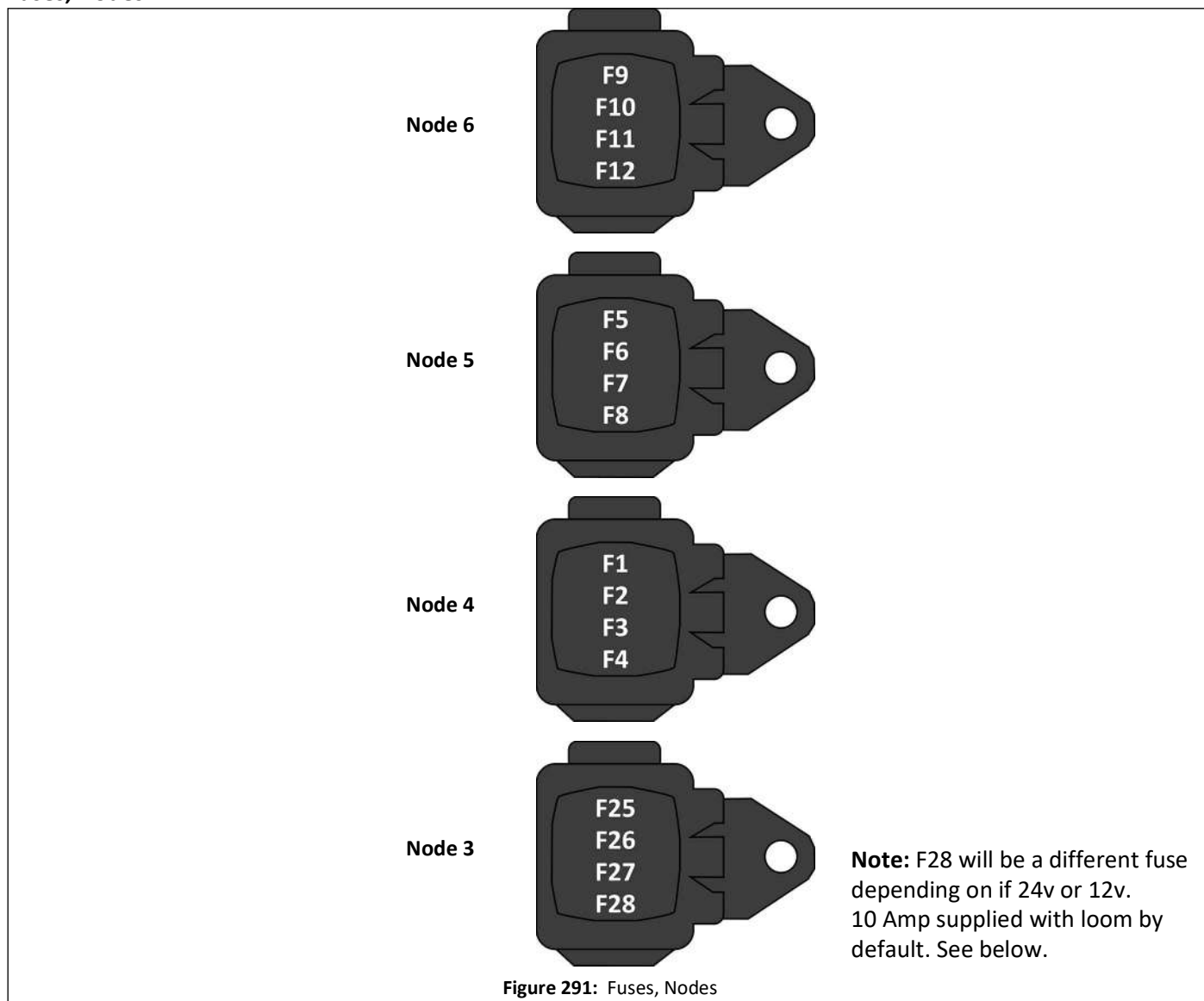

Figure 291: Fuses, Nodes

Item	Part No	Qty	Description	
F9	014289	1	Fuse, blade, 15 Amp, Node 6 Battery+ (Pin 34 Terminal 30)	331
F10	014289	1	Fuse, blade, 15 Amp, Node 6 Battery+ (Pin 5 Terminal 30)	331
F11			Spare	
F12	004485	1	Fuse, blade, 2 Amp, Node 6 Ignition (Terminal 15)	331
F5	014289	1	Fuse, blade, 15 Amp, Node 5 Battery+ (Pin 34 Terminal 30)	331
F6	014289	1	Fuse, blade, 15 Amp, Node 5 Battery+ (Pin5 Terminal 30)	331
F7	014292	1	Fuse, blade, 30 Amp, Node 5 Cab Supply	331
F8	004485	1	Fuse, blade, 2 Amp, Node 5 Ignition (Terminal 15)	331
F1	014289	1	Fuse, blade, 15 Amp, Node 4 Battery+ (Pin 34 Terminal 30)	331
F2	014289	1	Fuse, blade, 15 Amp, Node 4 Battery+ (Pin 5 Terminal 30)	331
F3	014286	1	Fuse, blade, 5 Amp, Node 4 Switches	331
F4	004485	1	Fuse, blade, 2 Amp, Node 4 Ignition (Terminal 15)	331
F25	014286	1	Fuse, blade, 5 Amp, Node 3 Ignition (Terminal 15)	331
F26	014286	1	Fuse, blade, 5 Amp, Alternator	331
F27	014289	1	Fuse, blade, 15 Amp, Node 3 Battery+	331
F28	014288	1	Fuse, blade, 10 Amp, Fuel Pump, <b>24v</b>	331
F28	014290	1	Fuse, blade, 20 Amp, Fuel Pump, <b>12v</b>	331

Battery junction box

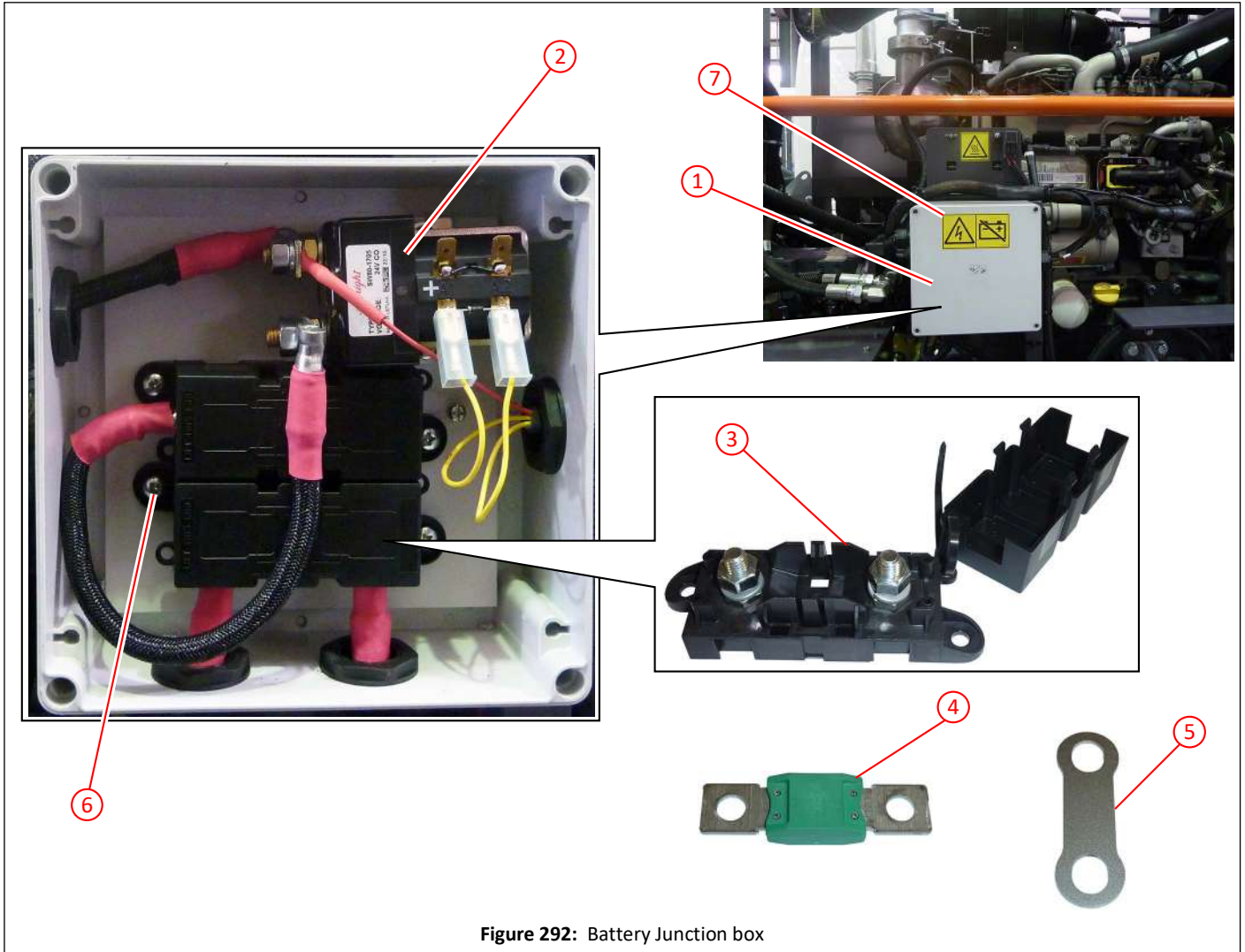

Figure 292: Battery Junction box

Item	Part No	Qty	Description	
①	043350	1	Battery junction box, includes the lid, lid fixings and the 4 battery cables	350
②	034207	1	Relay, glow plug heat, K5, <b>24v</b>	331
②	038571	1	Relay, glow plug heat, K5, <b>12v</b>	331
③	004506	2	Mega fuse holder	
④	004422	2	Mega fuse 125 Amp, F30 and F31	331
⑤	043381	1	BUS bar, mega fuse, connects the two mega fuses on the right hand side	
⑥	011115	6	Self tapping screw, No.10 x 1/2" POZI, for fitting mega fuse holder and relay	
⑦	043268	1	Label - Warning electrical	
NI	043344	1	Loom, DEUTZ engine	330
	043380	1	Junction box assembly, includes items ①-⑦, <b>24v</b>	
	044537	1	Junction box assembly, includes items ①-⑦, <b>12v</b>	

Work light



Figure 293: Work light

Item	Part No	Qty	Description	
①	047757	1	Work light, 12/24v	353
NI	043348	1	Loom, Node 5	353
NI	043719	1	Loom, gantry work light	353

LED marker rear light



Figure 294: LED rear marker light

Item	Part No	Qty	Description	
②	030773	1	LED rear marker light	
NI	036911	1	Loom, hopper	

Beacon



Figure 295: Beacon

Item	Part No	Qty	Description	
③	014064	1	Beacon, 24v	
③	010304	1	Beacon, 12v	
NI	036911	1	Loom, hopper	
NI	040727	1	Loom, twin beacons	

LED beacon



Figure 296: LED beacon

Item	Part No	Qty	Description
①	032721	1	Delta LED beacon, (SecuriLED)
②	040608	1	LED power distribution unit magnetic
NI	040725	1	Loom, LED (SecuriLED), long
NI	040726	1	Loom, LED (SecuriLED), short
NI	041172	1	Loom, LED
NI	040722	1	Loom, Y cable, power distribution
NI	004049	As req	Cable, 9/0.30 twin core round
NI	004161	As req	Conduit (split), flexible, ø15.7

Cameras



Figure 297: Cameras

Item	Part No	Qty	Description
③	040354	1	Camera
④	043897	1	Camera, eyeball
⑤	040353	1	Power supply and cable, camera
NI	000484	2	UM & L socket terminal caps
NI	040355	1	Cable, camera, 15m
NI	040719	1	Cable, camera, 5m
NI	040718	1	Cable, camera, 2,5m



Wiring looms and cables

Part No	Description	
036842	M12 plug/cable and valve plug type B	
036908	Loom, over head boom, water switch, includes switch	140
036911	Loom, hopper	
036912	Loom, main controller keypad	318
036913	Loom, auxiliary controller (door pod) keypad	319
036914	Loom, main controller keypad, power/CAN	318
036915	Loom auxiliary controller (door pod), power/CAN	319
037047	Loom, hopper controller, cab	
037331	Loom, brush up/down pressure	
038013	Loom, cab	
038536	Cable, positive battery cable, red, <b>24v</b>	
039672	Cable, M12 to USB	
040349	Loom, display screen	
040726	Loom, LED (SecuriLED), Short	
040727	Loom, twin beacon	
041172	Loom, LED	
043344	Loom, DEUTZ engine	
043345	Loom, Node 3 - <b>Note:</b> Supplied with a 10 Amp fuse in F28 for <b>24v</b> . A 20 Amp fuse is required if <b>12v</b> .	
043346	Loom, Node 4	
043347	Loom, hydraulic block	
043348	Loom, Node 5	
043349	Loom, Node 6	
043435	Cable, battery positive starter	
043436	Cable, engine/CANbus earth, <b>24v</b>	
043719	Loom, gantry work light	
040353	Power supply and cable, camera	
040355	Cable, camera, 15m	
040719	Cable, camera, 5m	
040718	Cable, camera, 2.5m	
040722	Loom, Y cable, power distribution	
044530	Cable, engine/CANbus earth, <b>12v</b>	
044531	Cable, positive battery cable, red, <b>12v</b>	
004049	Cable, 9/0.30 twin core round	
046708	Loom, DEUTZ power supply, <b>12v</b> only	

Switches

Part No	Description	
036908	Loom, over head boom, water switch, includes switch	
038223	Switch, gantry work light, green	323,325
038543 *	Beacon switch, Renault	321
042049 *	Beacon switch, DAF	321

\*. Switches for other chassis manufacturers please contact Scarab Parts Department.



**Sensors**

Part No	Description	
032627	Proximity sensor, hopper raise	352
041698	Low level sensor, engine coolant expansion tank	436
036781	Float switch, with amp plug, water tank	203
035466	Fuel sender unit 450mm	347
045113	Water in fuel (WIF) sensor, fuel filter, with cable	
043797	Lubrication oil pressure sensor	
043814	Coolant temperature sender	

**i** For location of the engine sensors see the Engine section starting at page

**Fuses**

Part No	Description	
004495	Fuse, mini, 2 Amp	
004569	Fuse, mini, 3 Amp	
004391	Fuse, mini, 5 Amp	
004392	Fuse, mini, 7.5 Amp	
004393	Fuse, mini, 10 Amp	
004394	Fuse, mini, 15 Amp	
004395	Fuse, mini, 20 Amp	
004396	Fuse, mini, 25 Amp	
004397	Fuse, mini, 30 Amp	
004485	Fuse, blade, 2 Amp	
014284	Fuse, blade, 3 Amp	
014285	Fuse, blade, 4 Amp	
014286	Fuse, blade, 5 Amp	
014287	Fuse, blade, 7.5 Amp	
014288	Fuse, blade, 10 Amp	
014289	Fuse, blade, 15 Amp	
014290	Fuse, blade, 20 Amp	
014291	Fuse, blade, 25 Amp	
014292	Fuse, blade, 30 Amp	
004422	Mega fuse 125 Amp	327

**Relays**

Part No	Description	
014718	Relay, K1, K2, K6, <b>24v</b>	323,324
011768	Relay, K1, K2, K6, <b>12v</b>	323,324
034207	Relay, glow plug heat, F30, <b>24v</b>	327
038571	Relay, glow plug heat, F30, <b>12v</b>	327
043720	Timer relay, gantry work light, K7, <b>24v</b>	323
044511	Timer relay, gantry work light, K7, <b>12v</b>	323



# Engine frame and subframe

<i>Description</i>	<i>Page</i>
Engine frame .....	335
Engine frame and covers general arrangement .....	335
Covers, engine frame .....	336
Door, left hand side, engine frame .....	337
Door, right hand side, engine frame .....	338
Hydraulic oil tank mounting, engine frame .....	339
Hydraulic tank and fittings .....	340
Hydraulic tank and fittings .....	341
Node and pneumatics cabinet mounting, engine frame .....	342
Node and pneumatics cabinet .....	343
Node and pneumatics cabinet .....	344
Node and pneumatics cabinet .....	345
Fuel tank mounting, engine frame .....	346
Fuel tank, fittings .....	347
Combined intercooler/radiator/hydraulic oil cooler mounting, engine frame .....	348
Safety bar, engine frame .....	349
Battery junction box and hydraulic oil filters mounting, engine frame .....	350
Fuel filters and fuel pump mounting, engine frame .....	351
Hopper raised sensor, engine frame .....	352
Work light, engine frame .....	353
Exhaust stack mounting, engine frame .....	354
Air intake stack mounting, engine frame .....	355
Flow control valve block and hydraulic manifold mountings, engine frame .....	356
Engine cradle and mounts, rear, engine frame .....	357
Engine cradle and mounts, front, engine frame .....	358
Expansion tank mounting, engine frame .....	359
ECU cover mounting, engine frame .....	360
Hydraulic cabinet door fittings, engine frame .....	361
Hydraulic cabinet valve block fittings, engine frame .....	362
End panels, engine frame .....	363
Engine frame .....	364
Subframe general arrangement .....	365
Subframe .....	366
Subframe and pipe, hose and wiring support brackets .....	367
Hopper safety prop .....	368
Floor plate, subframe and engine frame .....	369
Subframe hopper lift ram mounting .....	370
Access ladder and grab handle, subframe and engine frame .....	371
Subframe to engine frame mounting .....	372
Subframe to chassis mounting general arrangement .....	373
Subframe to chassis mountings, DAF .....	374
Subframe to chassis mountings, position 1, DAF .....	375
Subframe to chassis mountings, position 2, DAF .....	376
Subframe to chassis mountings, position 3, DAF .....	377
Subframe to chassis mountings, position 4, DAF .....	378
Subframe to chassis mountings lateral support, left side, DAF .....	379
Subframe to chassis mountings lateral support, right side, DAF .....	380
Subframe to chassis mountings, SCANIA .....	381
Subframe to chassis mountings, position 1, SCANIA .....	382
Subframe to chassis mountings, position 2, SCANIA .....	383
Subframe to chassis mountings, position 3, SCANIA .....	384
Subframe to chassis mountings, position 4, SCANIA .....	385
Subframe to chassis mountings lateral support, left side, SCANIA .....	386

Subframe to chassis mountings lateral support, right side, SCANIA .....	387
Subframe to chassis mountings, VOLVO .....	388
Subframe to chassis mountings, position 1, VOLVO .....	389
Subframe to chassis mountings, position 2, VOLVO .....	390
Subframe to chassis mountings, position 3, VOLVO .....	391
Subframe to chassis mountings, position 4, VOLVO .....	392
Subframe to chassis mountings lateral support, left side, VOLVO .....	393
Subframe to chassis mountings lateral support, right side, VOLVO .....	394
Subframe to chassis mountings, IVECO .....	395
Subframe to chassis mountings, position 1, IVECO .....	396
Subframe to chassis mountings, position 2, IVECO .....	397
Subframe to chassis mountings, position 3, IVECO .....	398
Subframe to chassis mountings, position 4, IVECO .....	399
Subframe to chassis mountings lateral support, left side, IVECO .....	400
Subframe to chassis mountings lateral support, right side, IVECO .....	401
Subframe to chassis mountings, Mercedes .....	402
Subframe to chassis mountings, position 1, Mercedes .....	403
Subframe to chassis mountings, position 2, Mercedes .....	404
Subframe to chassis mountings, position 3, Mercedes .....	405
Subframe to chassis mountings, position 4, Mercedes .....	406
Subframe to chassis mountings lateral support, left side, Mercedes .....	407
Subframe to chassis mountings lateral support, right side, Mercedes .....	408
Subframe to chassis mountings MAN 18.290 .....	409
Subframe to chassis mountings, position 1, MAN .....	410
Subframe to chassis mountings, position 2, MAN .....	411
Subframe to chassis mountings, position 3, MAN .....	412
Subframe to chassis mountings, position 4, MAN .....	413
Subframe to chassis mountings lateral support, left side, MAN .....	414
Subframe to chassis mountings lateral support, right side, MAN .....	415
Subframe to chassis mountings, Freightliner M2 106 .....	416
Subframe to chassis mountings, position 1, Freightliner .....	417
Subframe to chassis mountings, position 2, Freightliner .....	418
Subframe to chassis mountings, position 3, Freightliner .....	419
Subframe to chassis mountings, position 4, Freightliner .....	420
Subframe to chassis mountings lateral support, left side, Freightliner .....	421
Subframe to chassis mountings lateral support, right side, Freightliner .....	422

Engine frame and covers general arrangement

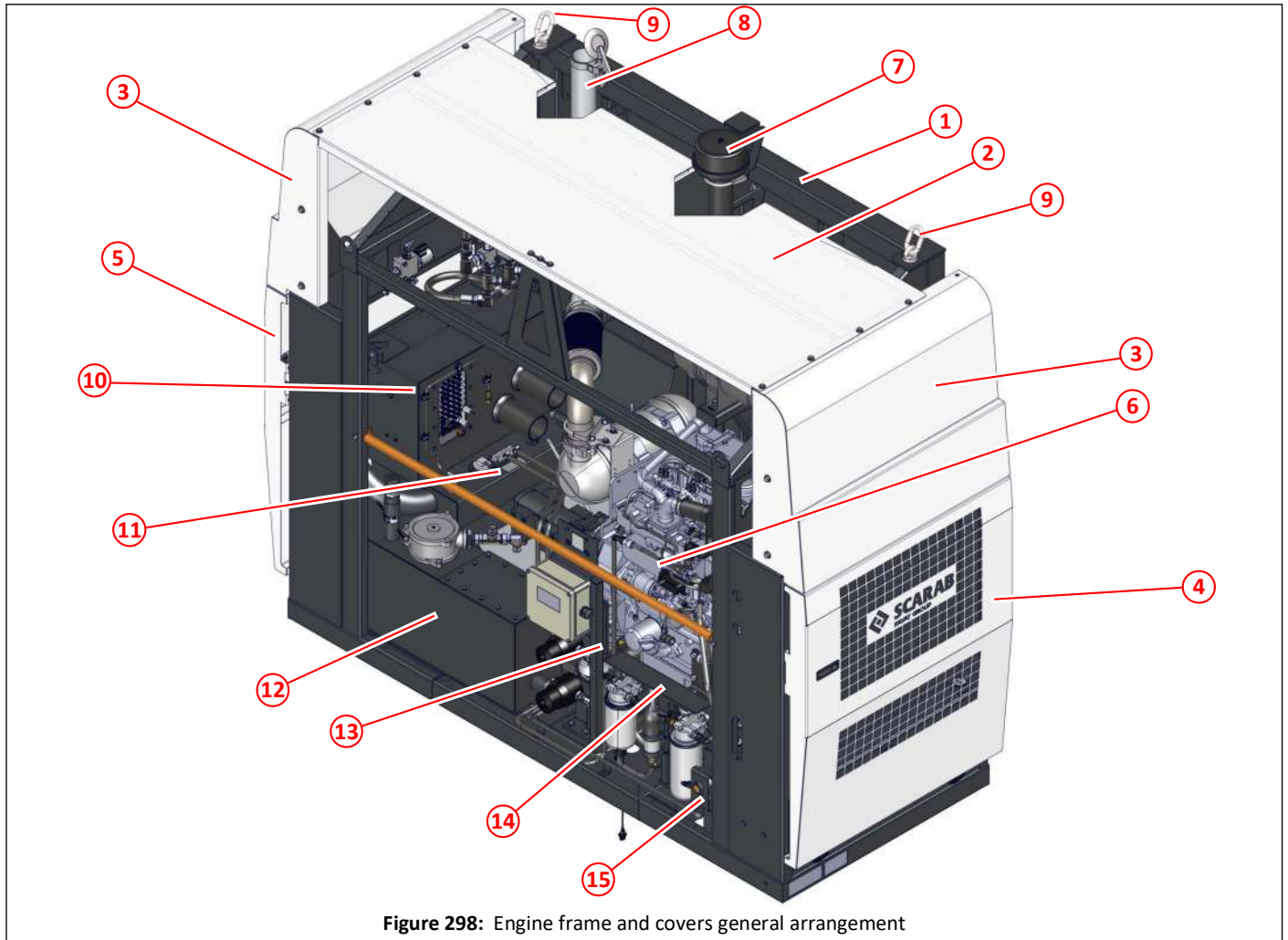

Figure 298: Engine frame and covers general arrangement

Item	Part No	Qty	Description	
①	042803	1	Engine frame	364
②	043011	1	Roof panel, engine frame	336
③	043013	2	Extension wing, engine frame	336
④	039997	1	Door, right hand side, engine frame	338
⑤	039998	1	Door, left hand side, engine frame	337
⑥			Engine, Deutz TCD 3.6 L4	357,358
⑦			Air stack, engine	355
⑧			Exhaust stack, engine	354
⑨	035941	2	Eye bolt, linked, 1.6T	364
⑩	042862	1	Node and pneumatics cabinet assembly, pre August 2017	342
⑪	045456	1	Node and pneumatics cabinet assembly, after August 2017, 24v	342
⑫	045457	1	Node and pneumatics cabinet assembly, after August 2017, 12v	342
⑬	042815	1	Fuel tank	346
⑭	042817	1	Hydraulic oil tank assembly	339
⑮			Mounting bracket, battery junction box and hydraulic filters	350
⑯	042955	1	Mounting bracket, fuel system	351
⑰	032627	1	Proximity sensor, hopper raised	352

## Covers, engine frame

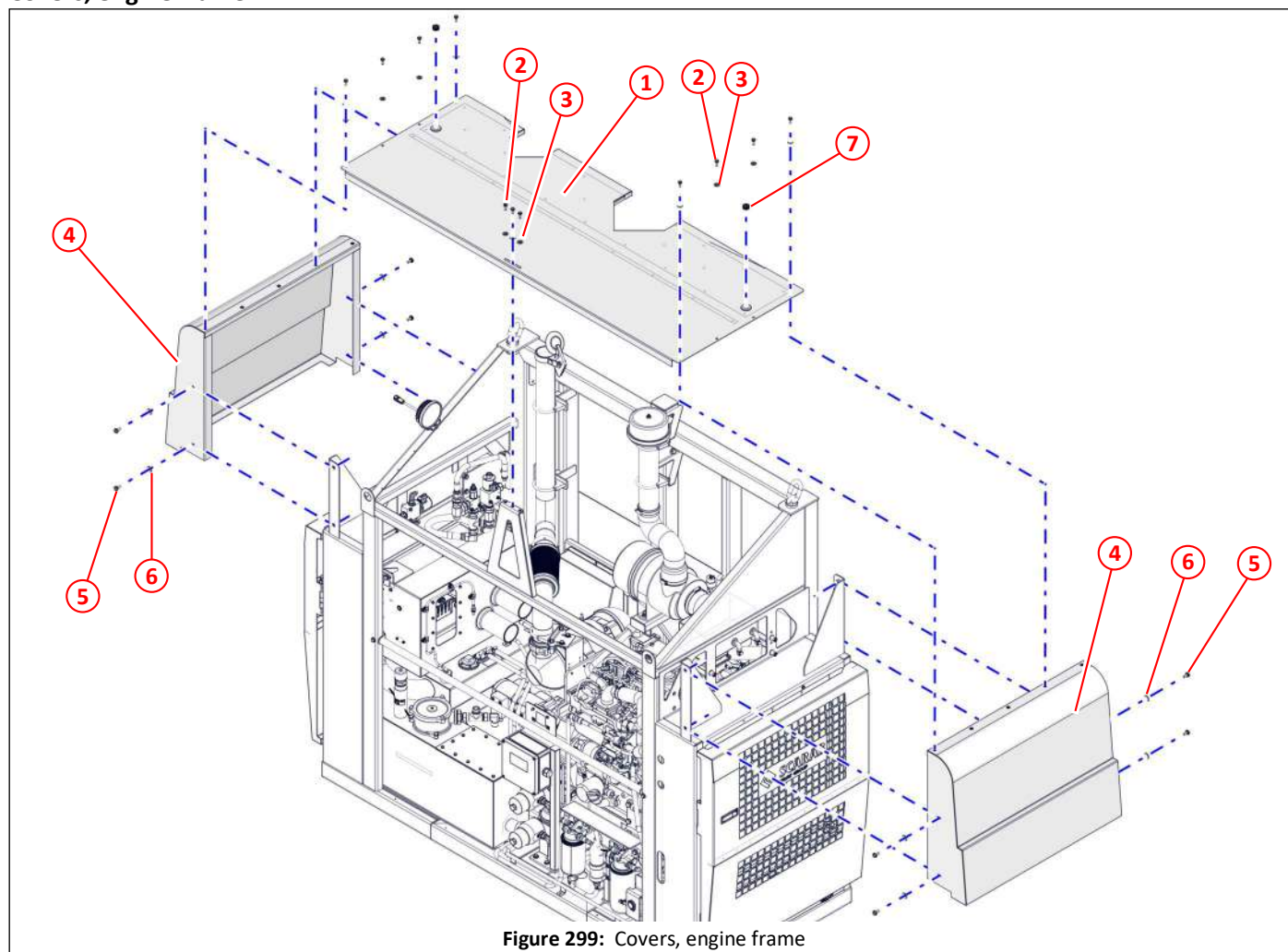

Figure 299: Covers, engine frame

Item	Part No	Qty	Description	
①	043011	1	Roof panel, engine frame	335
②	011010	11	Set screw M8 x 20	
③	011092	11	Plain washer M8	
④	043013	2	Extension wing, engine frame	335
⑤	011030	8	Set screw M10 x 20	
⑥	011094	8	Plain washer M10	
⑦	026173	2	Plug, plastic, ø25.4, black	



Door, left hand side, engine frame

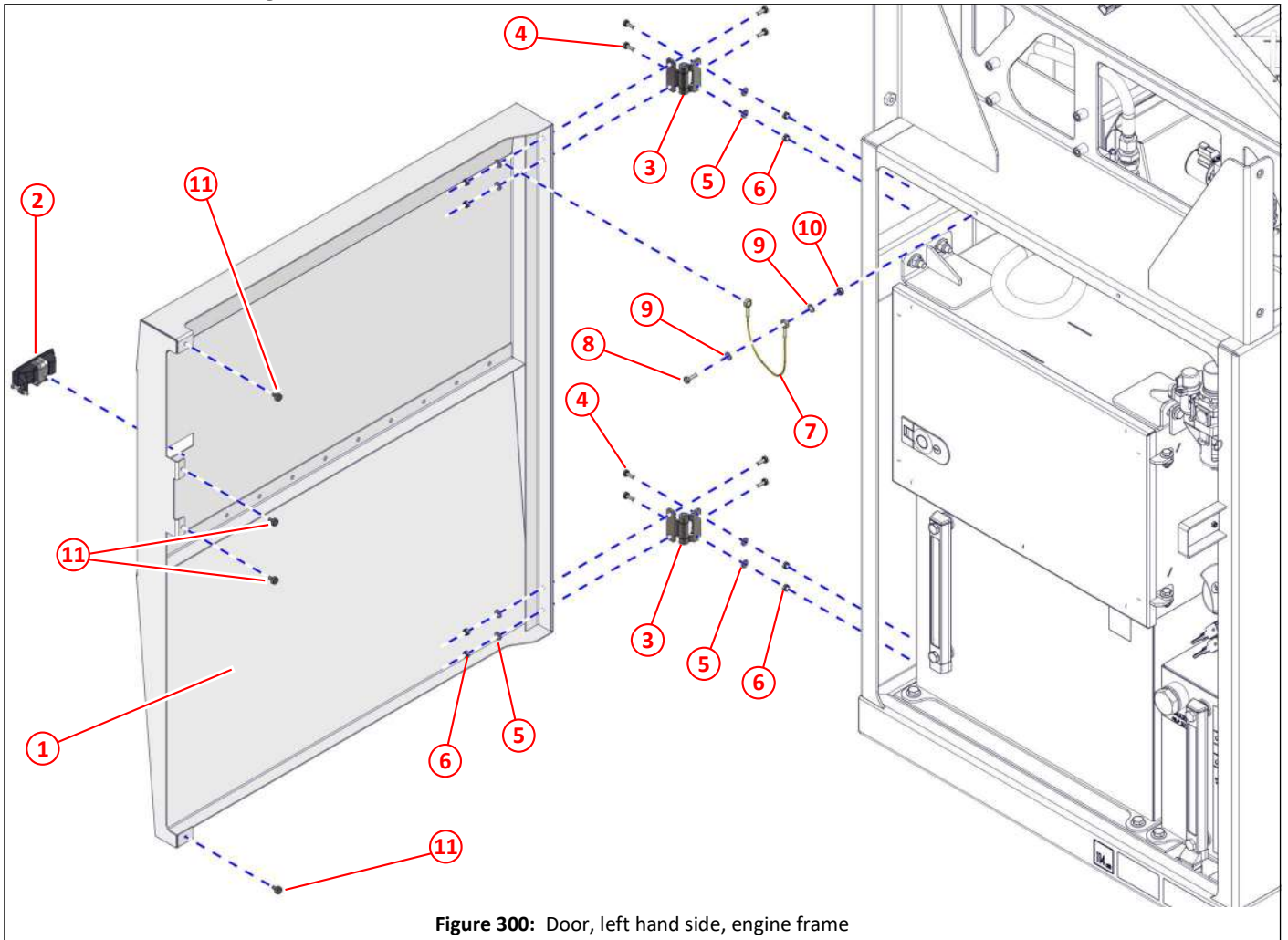

Figure 300: Door, left hand side, engine frame

Item	Part No	Qty	Description	
①	039998	1	Door, left hand side, engine frame	335
②	035662	1	Panel latch	
③	028583	2	Hinge	
④	011001	8	Set screw M6 x 16	
⑤	011090	8	Plain washer M6	
⑥	011071	8	Nyloc nut M6	
⑦	020711	1	Leash cable	
⑧	011067	1	Set screw M6 x 20	
⑨	011090	2	Plain washer M6	
⑩	011071	1	Nyloc nut M6	
⑪	042506	4	Rubber foot, push on	

Door, right hand side, engine frame

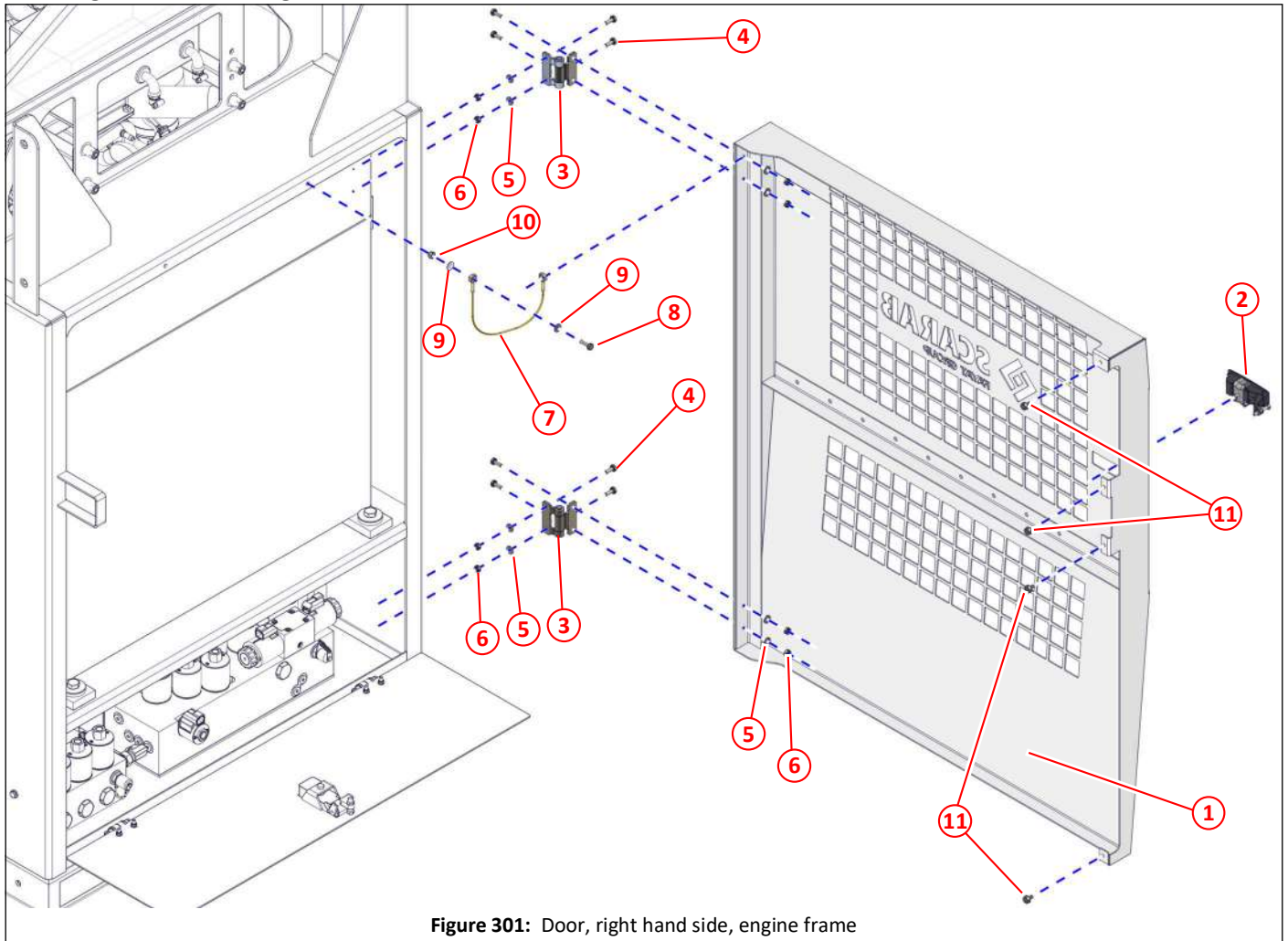

Figure 301: Door, right hand side, engine frame

Item	Part No	Qty	Description	
①	039997	1	Door, right hand side, engine frame	335
②	035662	1	Panel latch	
③	028583	2	Hinge	
④	011001	8	Set screw M6 x 16	
⑤	011090	8	Plain washer M6	
⑥	011071	8	Nyloc nut M6	
⑦	020711	1	Leash cable	
⑧	011067	1	Set screw M6 x 20	
⑨	011090	2	Plain washer M6	
⑩	011071	1	Nyloc nut M6	
⑪	042506	4	Rubber foot, push on	

Hydraulic oil tank mounting, engine frame

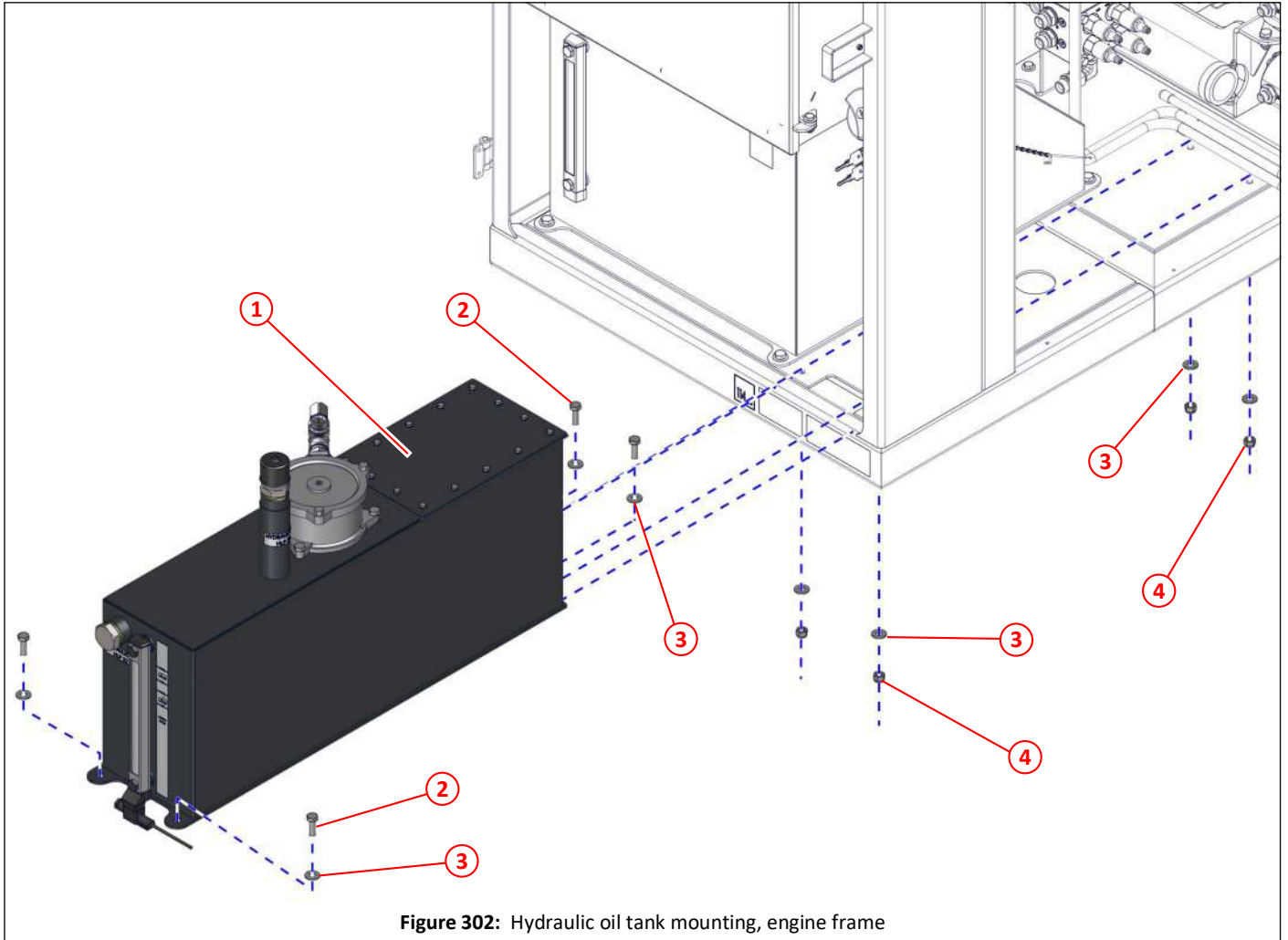

Figure 302: Hydraulic oil tank mounting, engine frame

Item	Part No	Qty	Description	
①	042817	1	Hydraulic oil tank, assembly	249,250
②	011032	4	Set screw M10 x 30	
③	011094	8	Plain washer M10	
④	011075	4	Nyloc nut M10	

Hydraulic tank and fittings

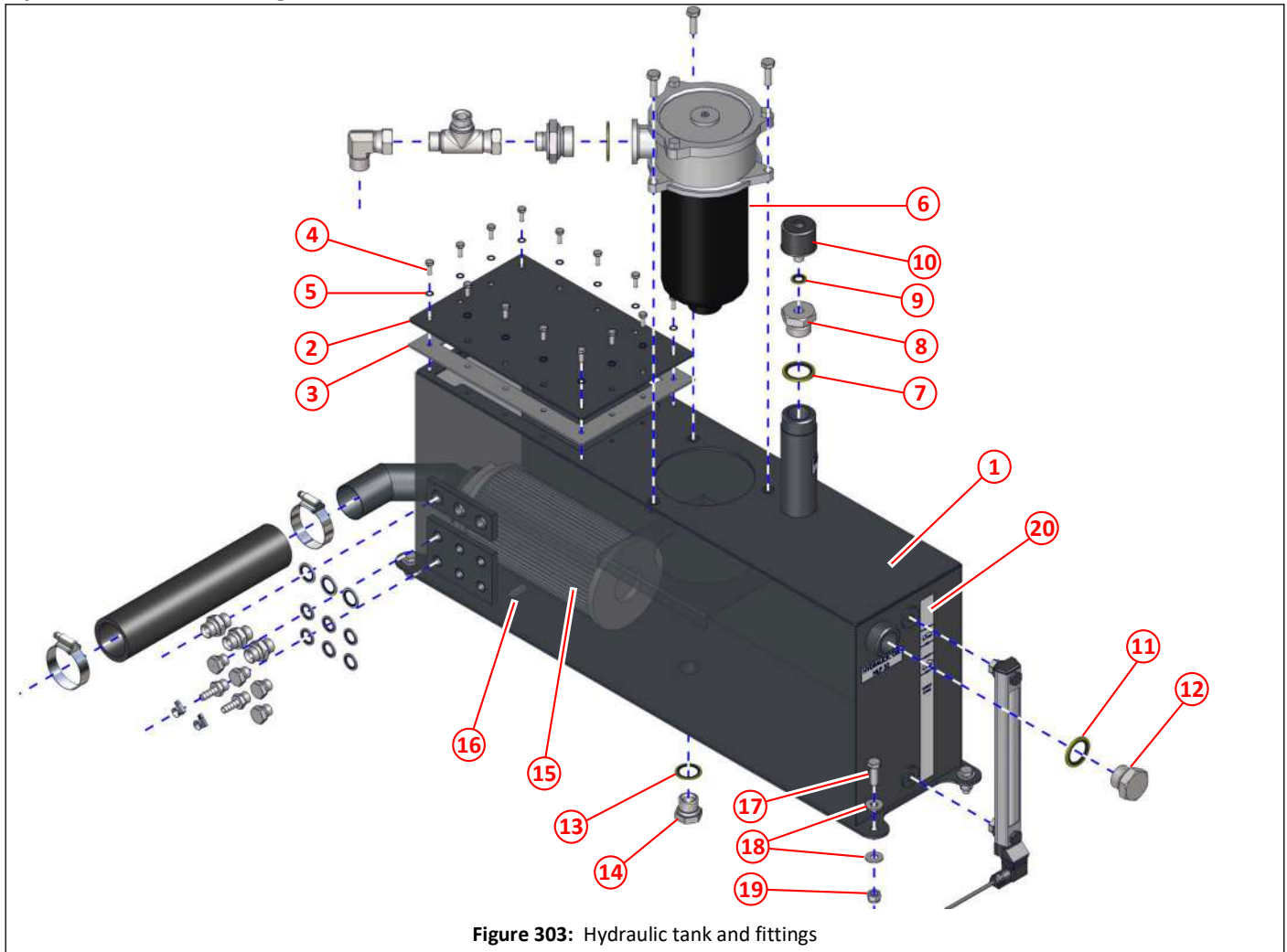

Figure 303: Hydraulic tank and fittings

Item	Part No	Qty	Description	
①	042818	1	Oil tank, hydraulic	249,250,339,341
②	042824	1	Lid, oil tank	
③	042866	1	Gasket, oil tank	
④	011001	14	Set screw M6 x 16	
⑤	000309	14	Lock washer, M6, zinc	
⑥	013123	1	Filter, return, includes filter element	341
⑦	011156	1	Dowty seal 1" BSP	
⑧	020689	1	Filler plug	
⑨	011152	1	Dowty seal 1/4" BSP	
⑩	020688	1	Filter, air breather	
⑪	011156	1	Dowty seal 1" BSP	
⑫	011136	1	Plug 1" BSP	
⑬	011155	1	Dowty seal 3/4" BSP	
⑭	011244	1	Plug 3/4" BSP	
⑮	020687	1	Filter. element, suction	
⑯	010305	1	Magnet	
⑰	011032	4	Set screw M10 x 30	
⑱	011094	8	Plain washer M10	
⑲	011075	4	Nyloc nut M10	
⑳	044831	1	Label - Hydraulic oil level	

Hydraulic tank and fittings

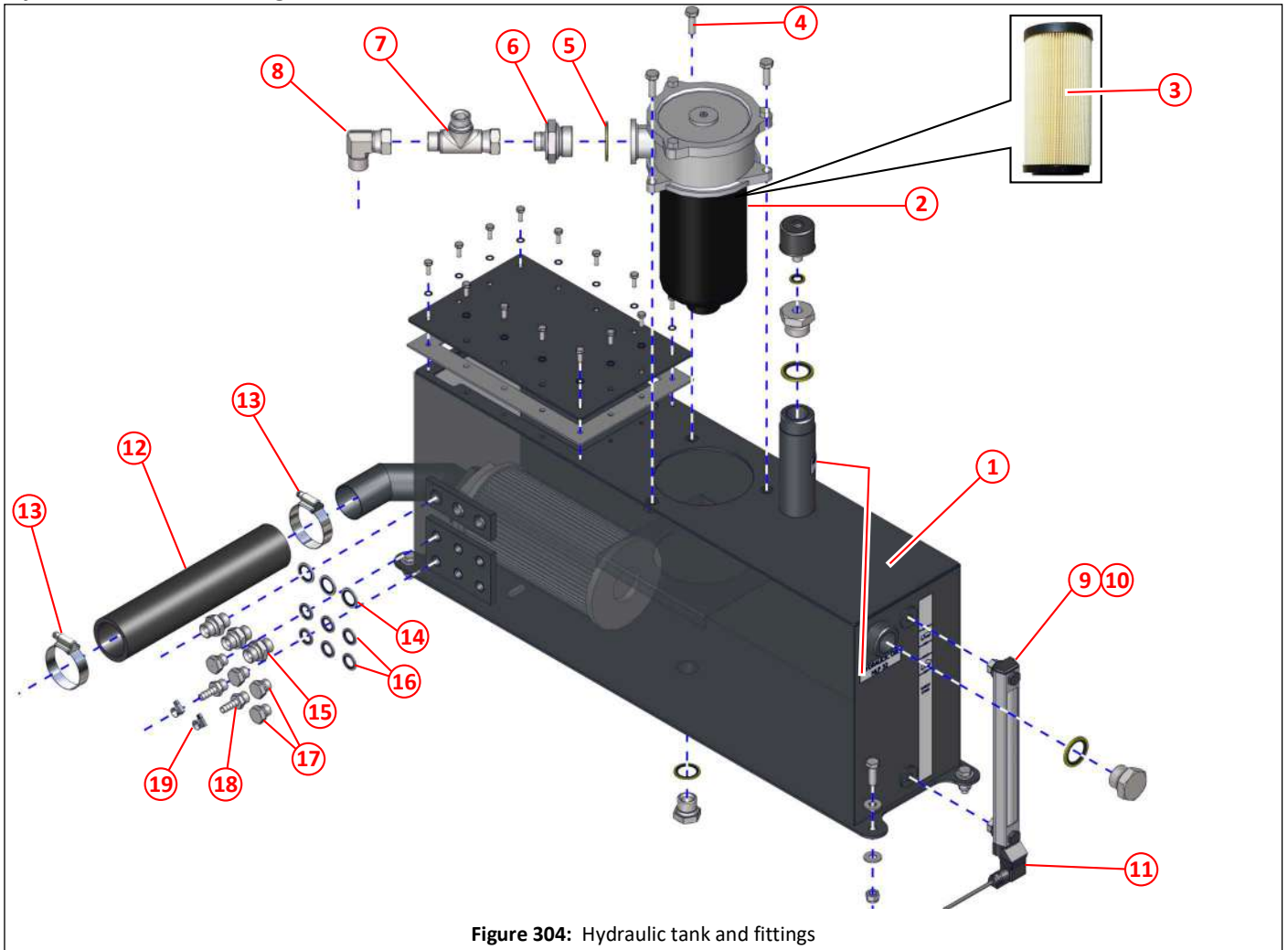

Figure 304: Hydraulic tank and fittings

Item	Part No	Qty	Description	
①	042818	1	Oil tank, hydraulic	249,250,339,340
②	013123	1	Filter, return, includes filter element	
③	013125	1	Element, return filter	
NI	024405	1	Seal kit, return filter	
④	011032	3	Set screw M10 x 30	
⑤	011150	1	Dowty seal 1 1/4" BSP	
⑥	011184	1	Adapter 1 1/4" BSP x 3/4" BSP reducer	
⑦	011197	1	Tee, 3/4" BSP, nut on run, branch return from suction fan circuit	
⑧	011174	1	Elbow, swivel, 3/4" BSP, connection return from suction fan	
⑨	024039	1	Level gauge, with switch and fitting screws	
⑩	021979	2	Sealing washer	
⑪	036842	1	M12 plug/cable and valve, plug type B	
⑫	031272	1	Hose 2" x 300, suction, to hydraulic suction manifold	251
⑬	029778	2	Hose clamp, worm drive, high torque, (ø40-ø70)	
⑭	011154	3	Dowty seal 1/2" BSP	
⑮	011160	3	Adapter, M/M, 1/2" BSP	
⑯	011153	6	Dowty seal 3/8" BSP	
⑰	011242	4	Plug 3/8" BSP	
⑱	010923	2	Adapter, 3/8" BSP x 3/8" hose tail	
⑲	010516	2	Hose clamp, worm drive, No. M00 (ø11mm-ø16mm)	



Node and pneumatics cabinet mounting, engine frame

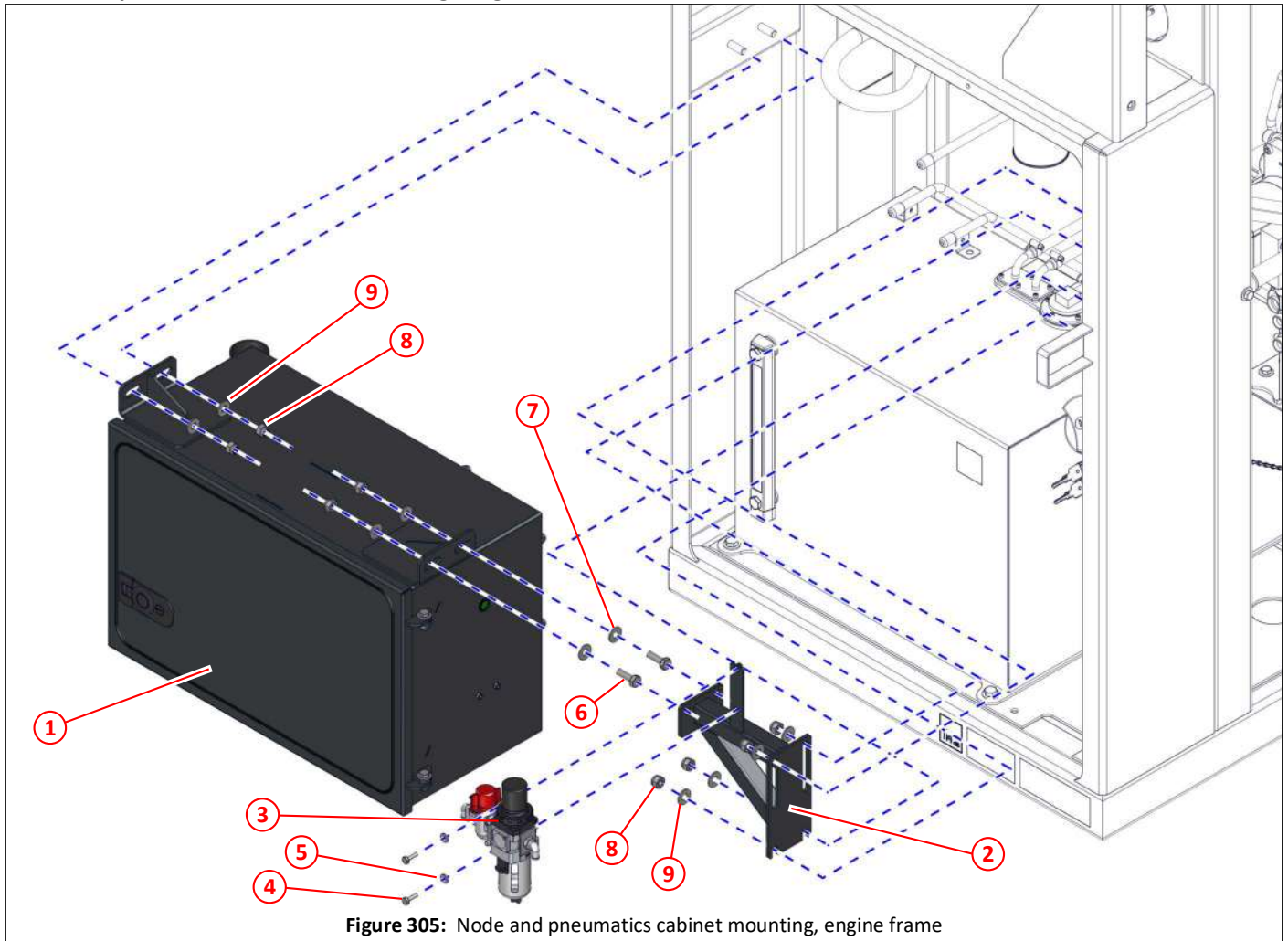

Figure 305: Node and pneumatics cabinet mounting, engine frame

Item	Part No	Qty	Description	
①	042862	1	Node and pneumatics cabinet assembly, pre August 2017	335,343
①	045456	1	Node and pneumatics cabinet assembly, after August 2017, 24v	335,343
①	045457	1	Node and pneumatics cabinet assembly, after August 2017, 12v	335,343
②	043041	1	Support bracket, node and pneumatics cabinet	
③	032519	1	Air regulator and filter	304
④	011067	2	Set screw M6 x 20	
⑤	011090	2	Plain washer M6	
⑥	011032	2	Set screw M10 x 30	
⑦	011094	2	Plain washer M10	
⑧	011075	4	Nyloc nut M10	
⑨	011094	4	Plain washer M10	



Node and pneumatics cabinet

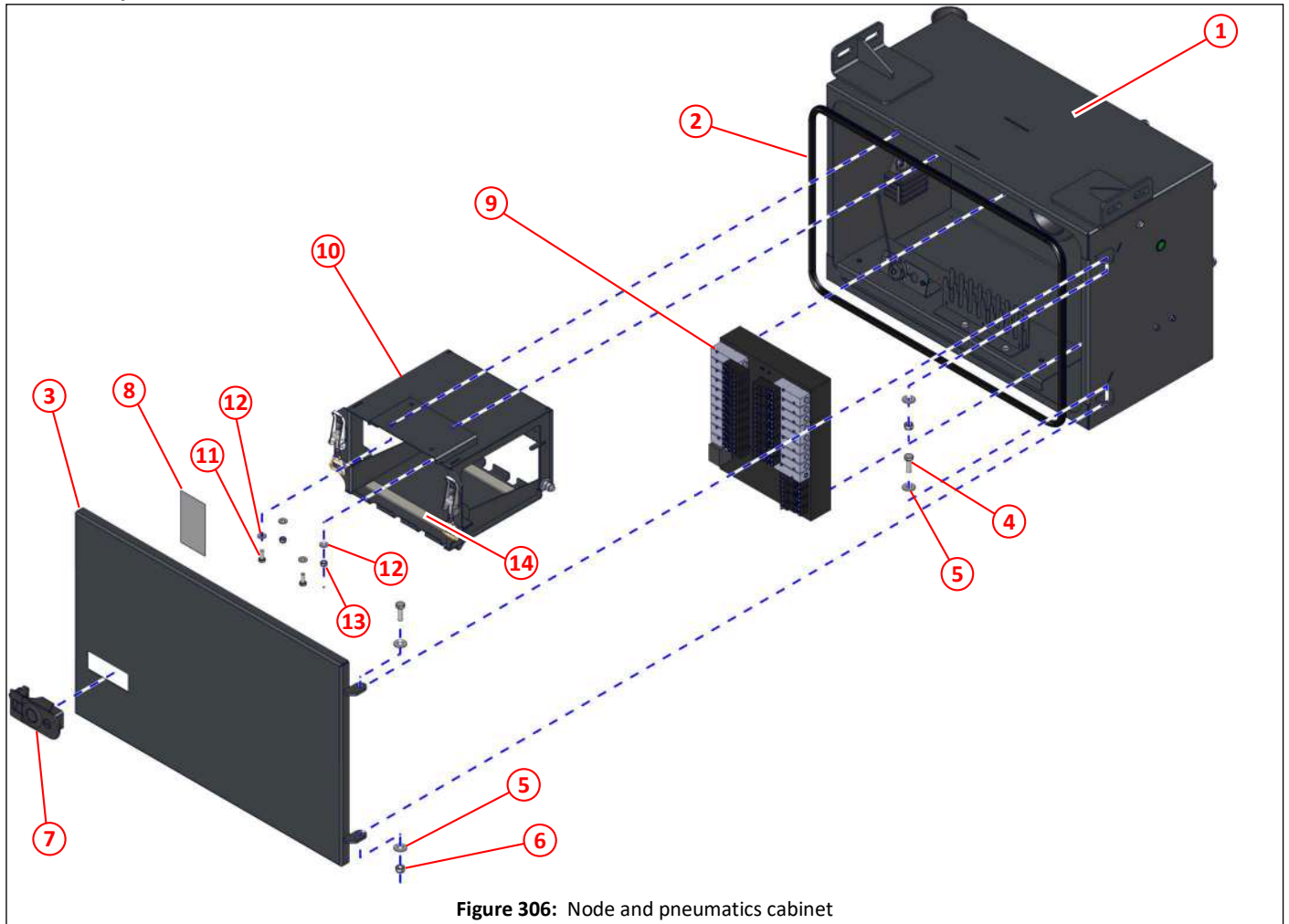

Figure 306: Node and pneumatics cabinet

Item	Part No	Qty	Description	
①	042863	1	Node and pneumatics cabinet	342
①	045456	1	Node and pneumatics cabinet assembly, after August 2017, 24v	342
①	045457	1	Node and pneumatics cabinet assembly, after August 2017, 12v	342
②	025222	As req	Titanfast section DX78	
③	042898	1	Door, Node and pneumatics cabinet	
④	011011	2	Set screw M8 x 25	
⑤	011092	4	Plain washer M8	
⑥	011073	2	Nyloc nut M8	
⑦	033634	1	Latch, sealed, locking	
⑧	043458	1	Label - Fuses, node and pneumatics cabinet	
⑨	034631	1	Pneumatics board, populated, pre August 2017	292
⑨	045293	1	Pneumatics board (HAF), populated, after August 2017, 24v	294
⑨	045303	1	Pneumatics board (HAF), populated, after August 2017, 12v	294
⑩	037996	1	Node carrier	
⑪	011001	2	Set screw M6 x 16	
⑫	011090	4	Plain washer M6	
⑬	011071	2	Nyloc nut M6	
⑭	013645	As req	Inseal strip 3 x 19	

Node and pneumatics cabinet

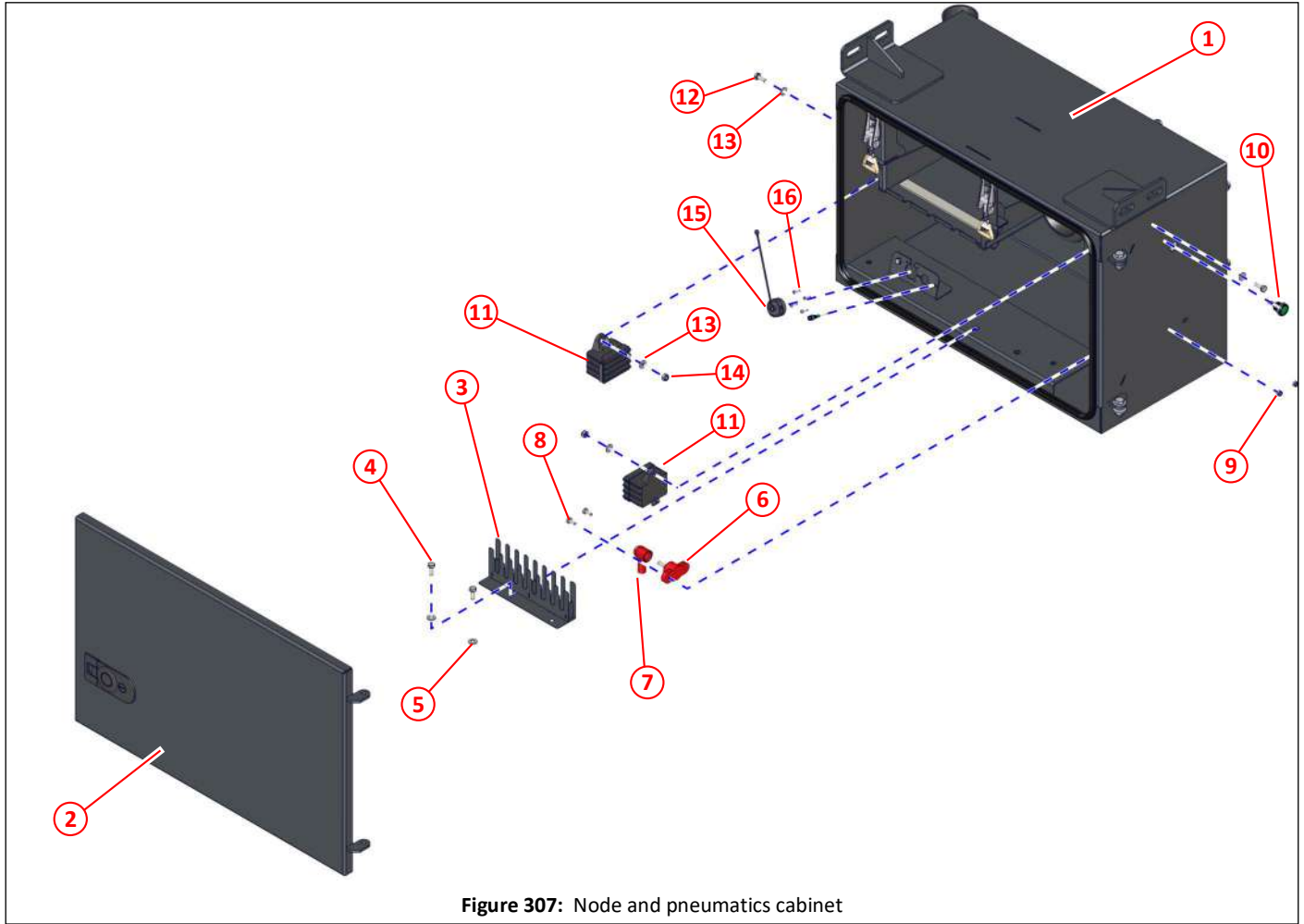

Figure 307: Node and pneumatics cabinet

Item	Part No	Qty	Description	
①	042863	1	Node and pneumatics cabinet	342
①	045456	1	Node and pneumatics cabinet assembly, after August 2017, 24v	342
①	045457	1	Node and pneumatics cabinet assembly, after August 2017, 12v	342
②	042898	1	Door, Node and pneumatics cabinet	
③	037994	1	Splice saver rack	
④	011001	2	Set screw M6 x 16	
⑤	011090	2	Plain washer M6	
⑥	036843	1	Power post, red	325
⑦	004489	1	Rubber boot, red, for power post	325
⑧	100103	2	Pan head Pozidrive screw M5 x 12	
⑨	000155	2	Nyloc nut M5	
⑩	038223	1	Switch, gantry work light, green, on side of node cabinet	325
⑪	036844	2	Power connection link	324
⑫	011001	2	Set screw M6 x 16	
⑬	011090	4	Plain washer M6	
⑭	011071	2	Nyloc nut M6	
⑮	043377	1	Socket dust cap, for diagnostic plug	
⑯	000179	4	Socket button head screw M3 x 12, black	

Node and pneumatics cabinet

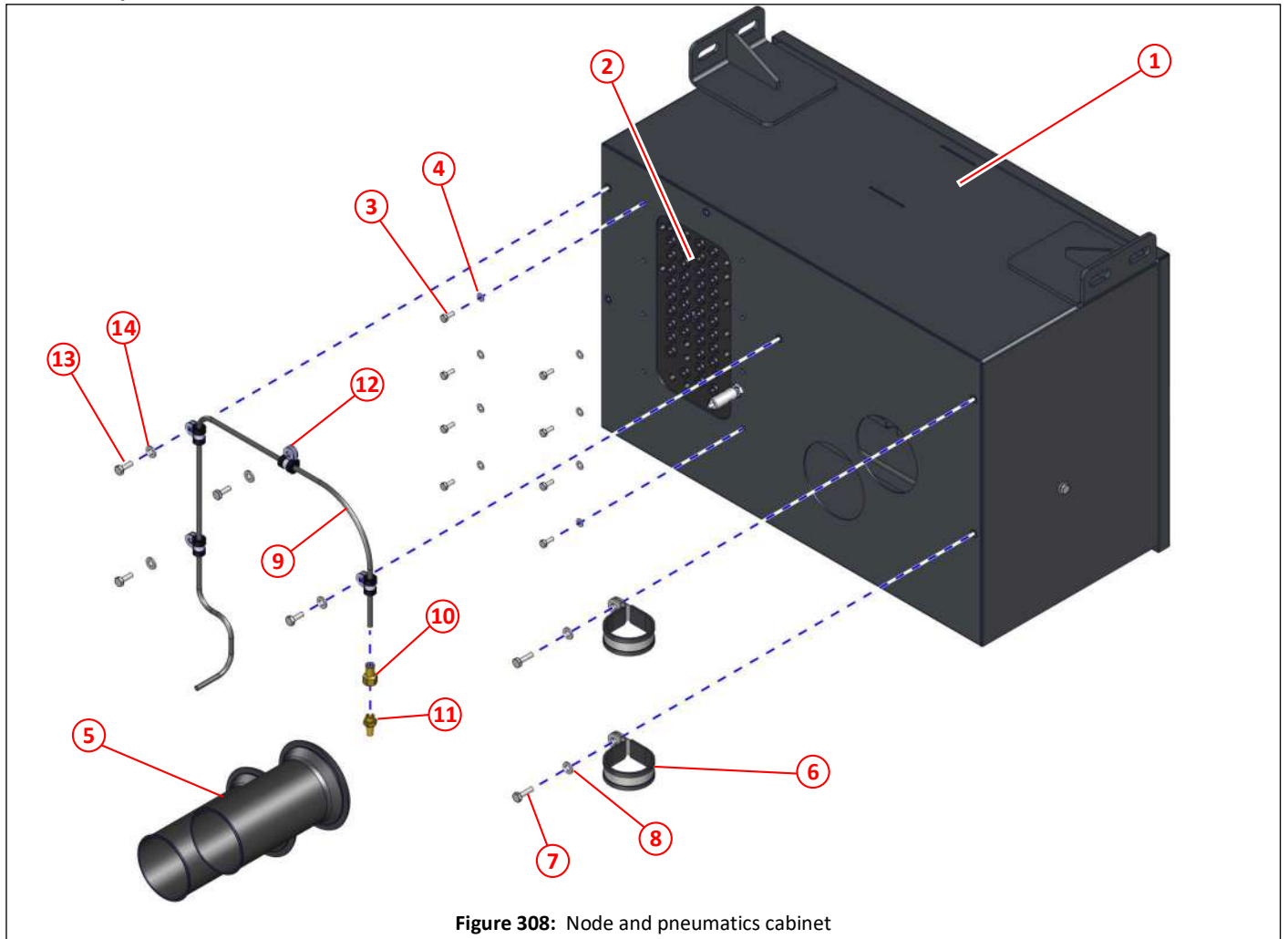

Figure 308: Node and pneumatics cabinet

Item	Part No	Qty	Description	
①	042863	1	Node and pneumatics cabinet	342
①	045456	1	Node and pneumatics cabinet assembly, after August 2017, 24v	342
①	045457	1	Node and pneumatics cabinet assembly, after August 2017, 12v	342
②		1	Pneumatics board	292,294
③	000097	8	Bolt M5 x 12	
④	000410	8	Plain washer	
⑤	034807	2	Panel sock	
⑥	005055	2	P-clip ø50	
⑦	011067	2	Set screw M6 x 20	
⑧	011090	2	Plain washer M6	
⑨	014572	As req	Air pipe, ø6 X 1 WT, black (connects to fuel tank breather)	347
⑩	024652	1	Union, female, ø6 x 1/8" BSP	
⑪	006006	1	Muffler 1/8" BSP	
⑫	003005	4	P-clip ø6	
⑬	011001	4	Set screw M6 x 16	
⑭	011090	4	Plain washer M6	

## Fuel tank mounting, engine frame

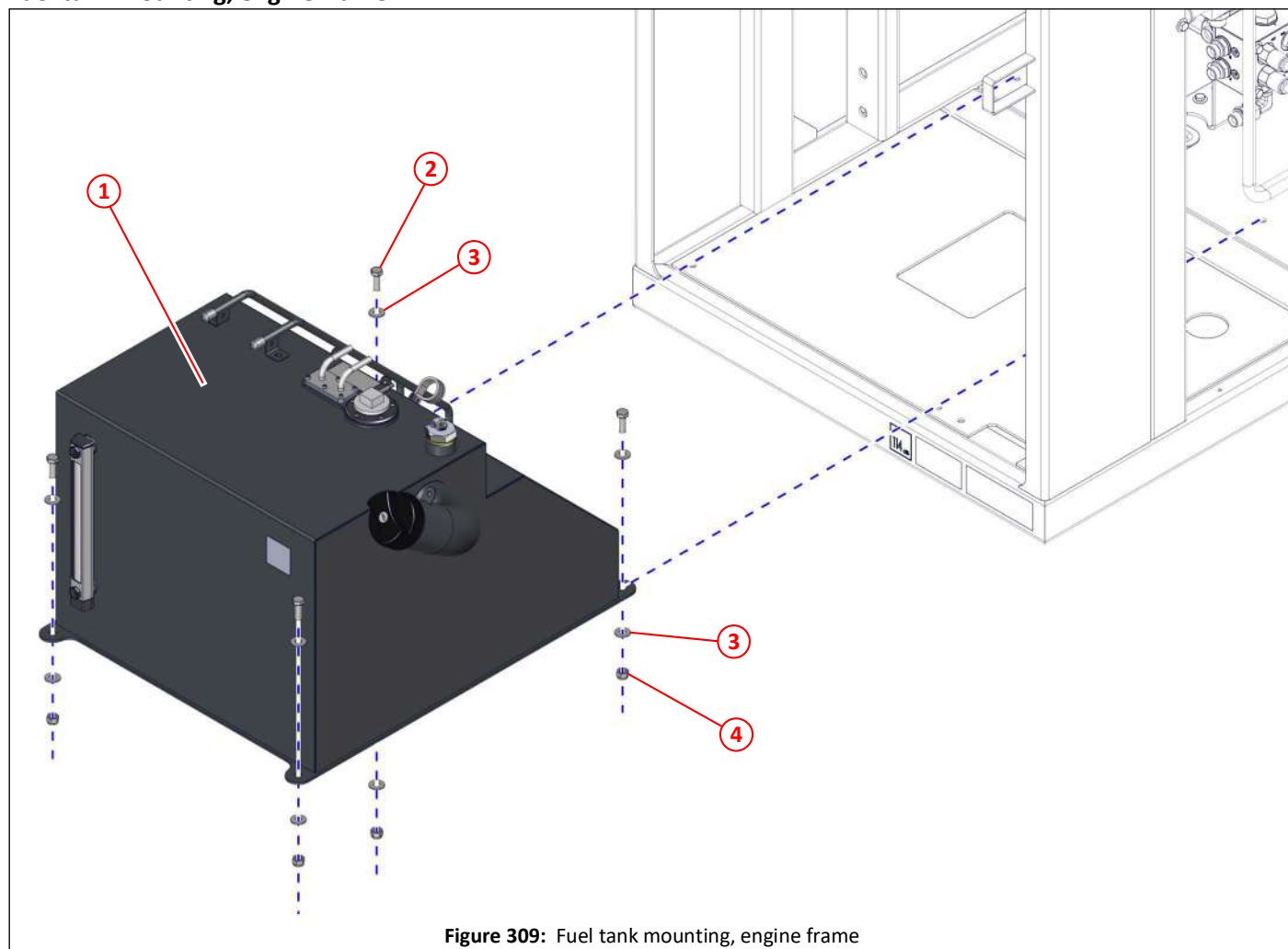

Figure 309: Fuel tank mounting, engine frame

Item	Part No	Qty	Description
①	042814	1	Fuel tank assembly
②	011032	4	Set screw M10 x 30
③	011094	8	Plain washer M10
④	011075	4	Nyloc nut M10

Fuel tank, fittings

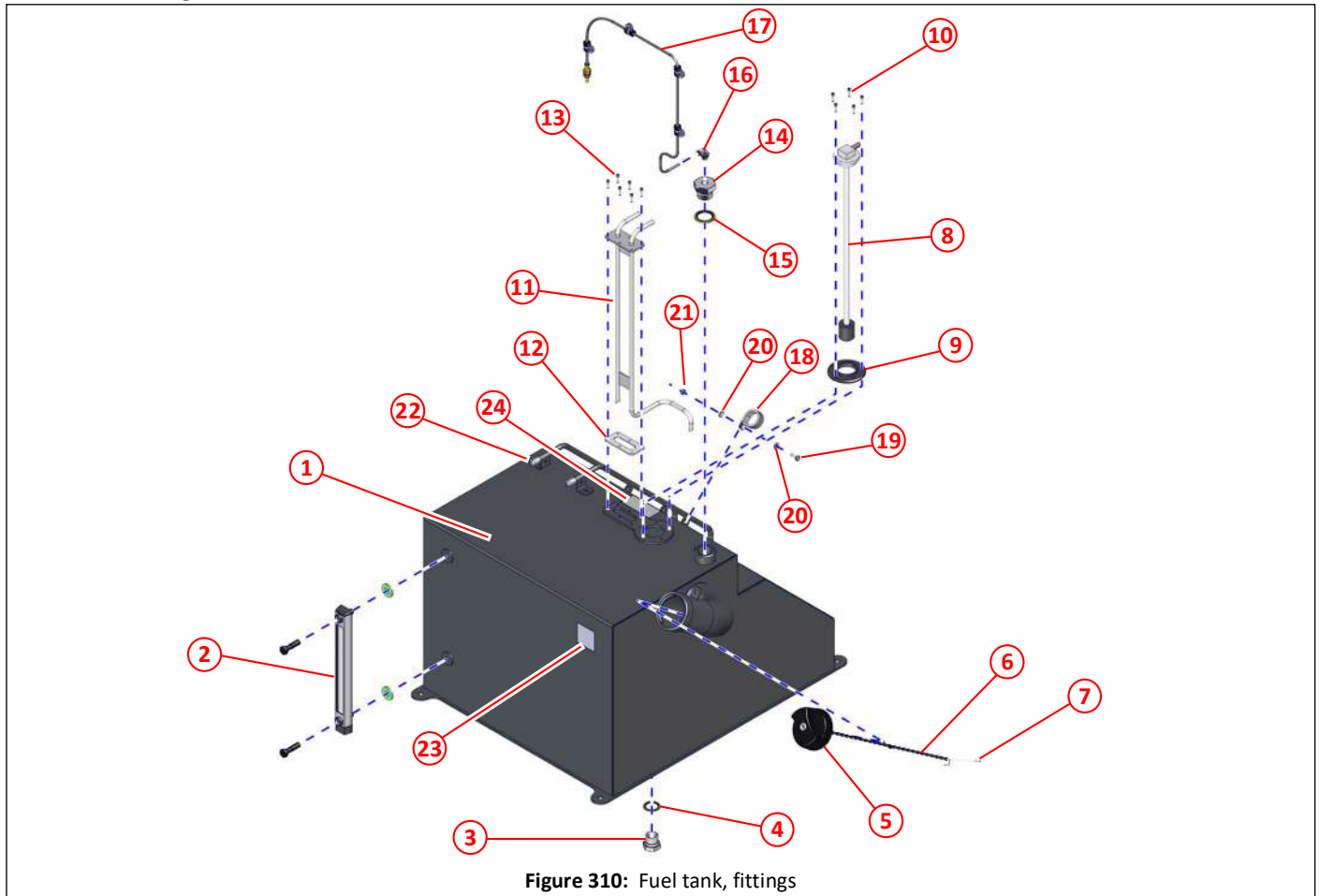
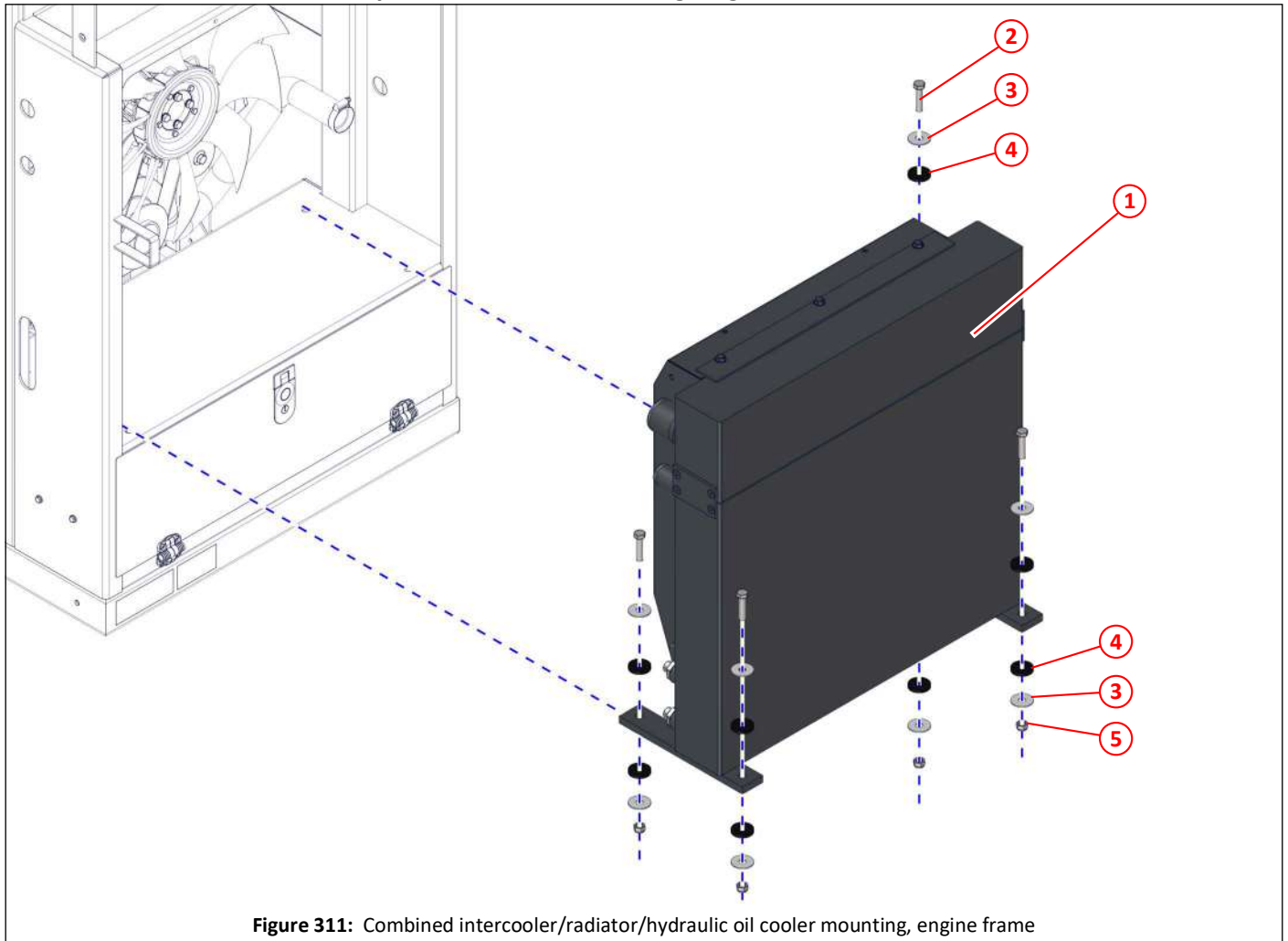

Figure 310: Fuel tank, fittings

Item	Part No	Qty	Description	
①	042815	1	Fuel tank	
②	032662	1	Level gauge, fuel tank, includes seals and bolts	
③	011244	1	Plug $\frac{3}{4}$ " BSP	
④	011155	1	Dowty seal $\frac{3}{4}$ " BSP	
⑤	032734	1	Fuel cap, locking	
⑥	005103	1	Safety chain	
⑦	033329	1	Toggle	
⑧	035466	1	Fuel sender unit	331
⑨	028840	1	Fitting kit, fuel sender	
⑩	000142	5	Socket cap head screw M4 x 15, plated	
⑪	042961	1	Fuel feed/return	
⑫	031189	1	Seal, fuel feed/return	
⑬	000142	6	Socket cap head screw M4 x 15, plated	
⑭	020689	1	Plug, breather	
⑮	011156	1	Dowty seal 1" BSP	
⑯	023203	1	Elbow, push in, swivel, $\phi 6 \times \frac{1}{4}$ " BSP	
⑰		1	Breather, fuel tank	345
⑱	024705	1	P-clip $\phi 35$	
⑲	011001	1	Set screw M6 x 16	
⑳	011090	2	Plain washer M6	
㉑	011071	1	Nyloc nut M6	
㉒	043065	4	Pipe cap $\phi 12$	
㉓	043264	1	Label - Diesel	
㉔	043866	1	Label - Fuel feed/return	

## Combined intercooler/radiator/hydraulic oil cooler mounting, engine frame



**Figure 311:** Combined intercooler/radiator/hydraulic oil cooler mounting, engine frame

Item	Part No	Qty	Description	
①	042800	1	Combined intercooler/radiator/hydraulic cooler	248,437
②	000024	4	Set screw M12 x 50	
③	013448	8	Washer $\phi 13 \times \phi 40 \times 2$	
④	012969	8	Washer, rubber, $\phi 12 \times \phi 40 \times 6$	
⑤	011077	4	Nyloc nut M12	



Safety bar, engine frame

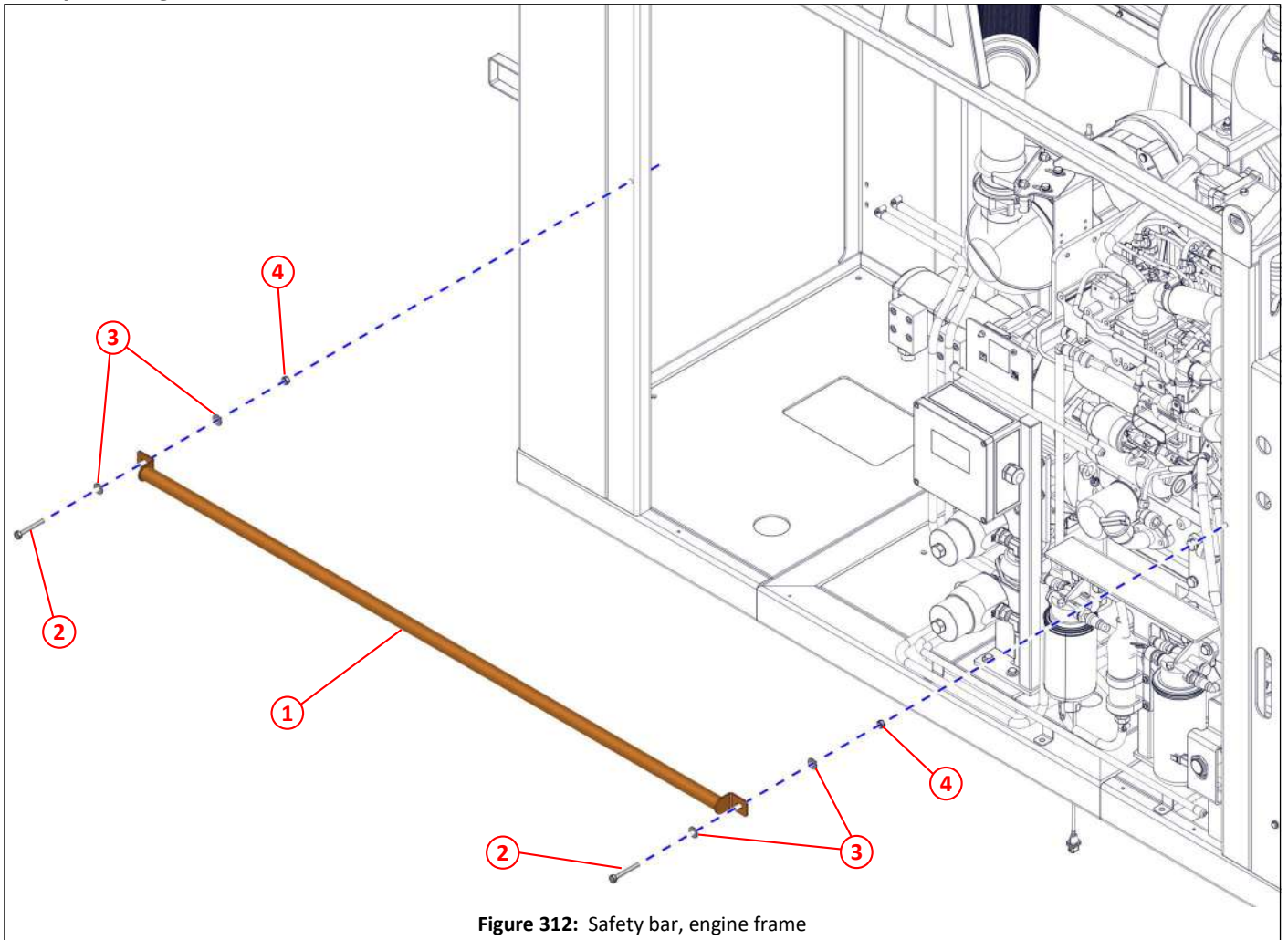

Figure 312: Safety bar, engine frame

Item	Part No	Qty	Description
①	034800	1	Safety bar, engine frame
②	011017	2	Bolt M8 x 60
③	011092	4	Plain washer M8
④	011073	2	Nyloc nut M8

Battery junction box and hydraulic oil filters mounting, engine frame

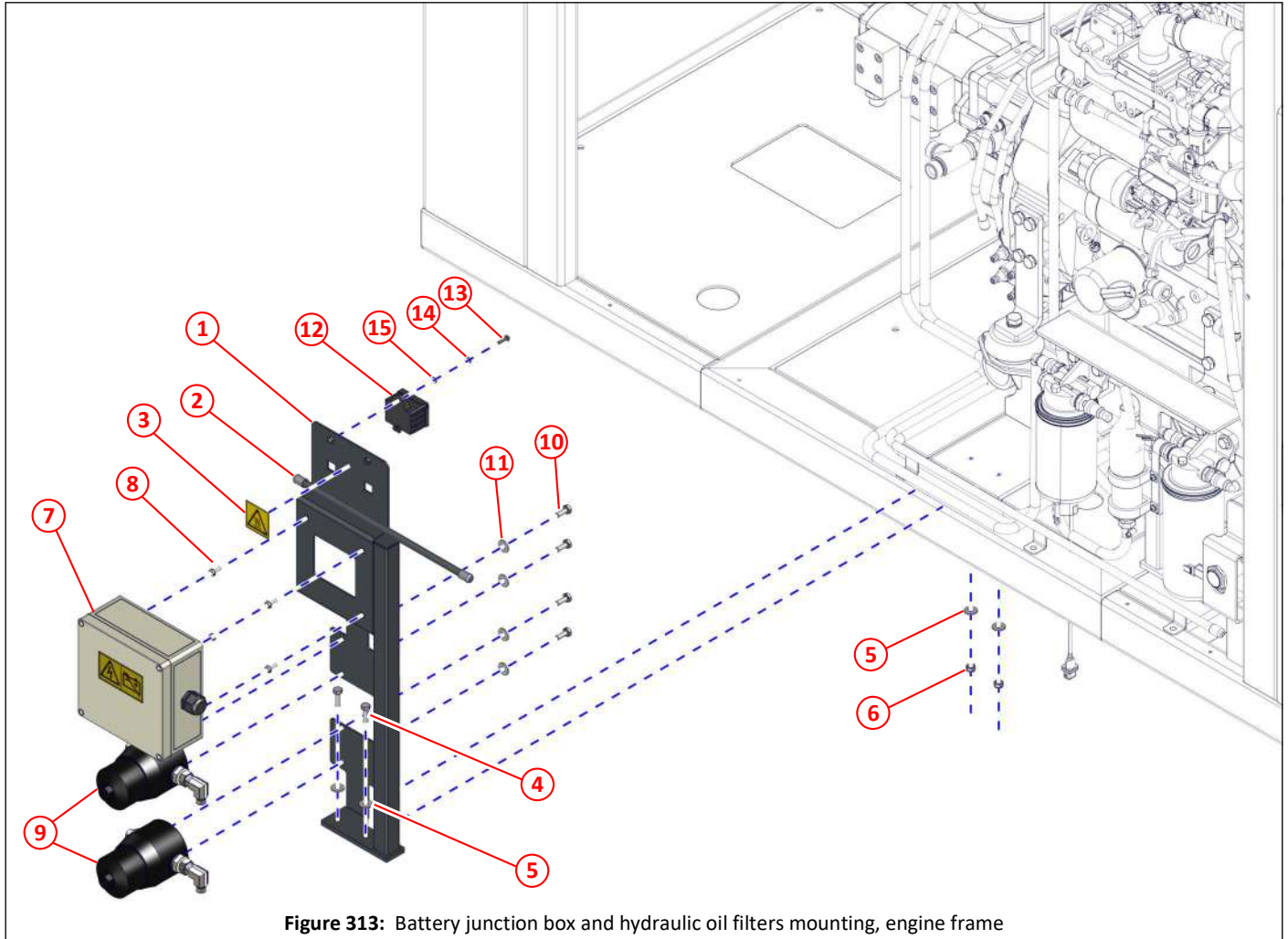

Figure 313: Battery junction box and hydraulic oil filters mounting, engine frame

Item	Part No	Qty	Description	
①	042957	1	Mounting bracket, battery junction box and hydraulic oil filters	
②	043065	2	Pipe cap, $\varnothing 12$	
③	043266	1	Label - Warning - Hot surface	
④	011011	2	Set screw M8 x 25	
⑤	011092	4	Plain washer M8	
⑥	011073	2	Nyloc nut M8	
⑦	043380	1	Battery junction box assembly, 24v	327
⑦	044537	1	Battery junction box assembly, 12v	327
⑧	011110	4	Pan head screw M6 x 16	
⑨	025103	2	Filter, hydraulic oil, high pressure	256
⑩	011010	4	Set screw M8 x 20	
⑪	011092	4	Plain washer M8	
⑫	036844	1	Power connection link, black	324
⑬	000381	1	Dome socket head screw, M5 x 20, stainless steel	
⑭	000411	1	Spring washer M5	
⑮	000410	1	Plain washer M5	

Fuel filters and fuel pump mounting, engine frame

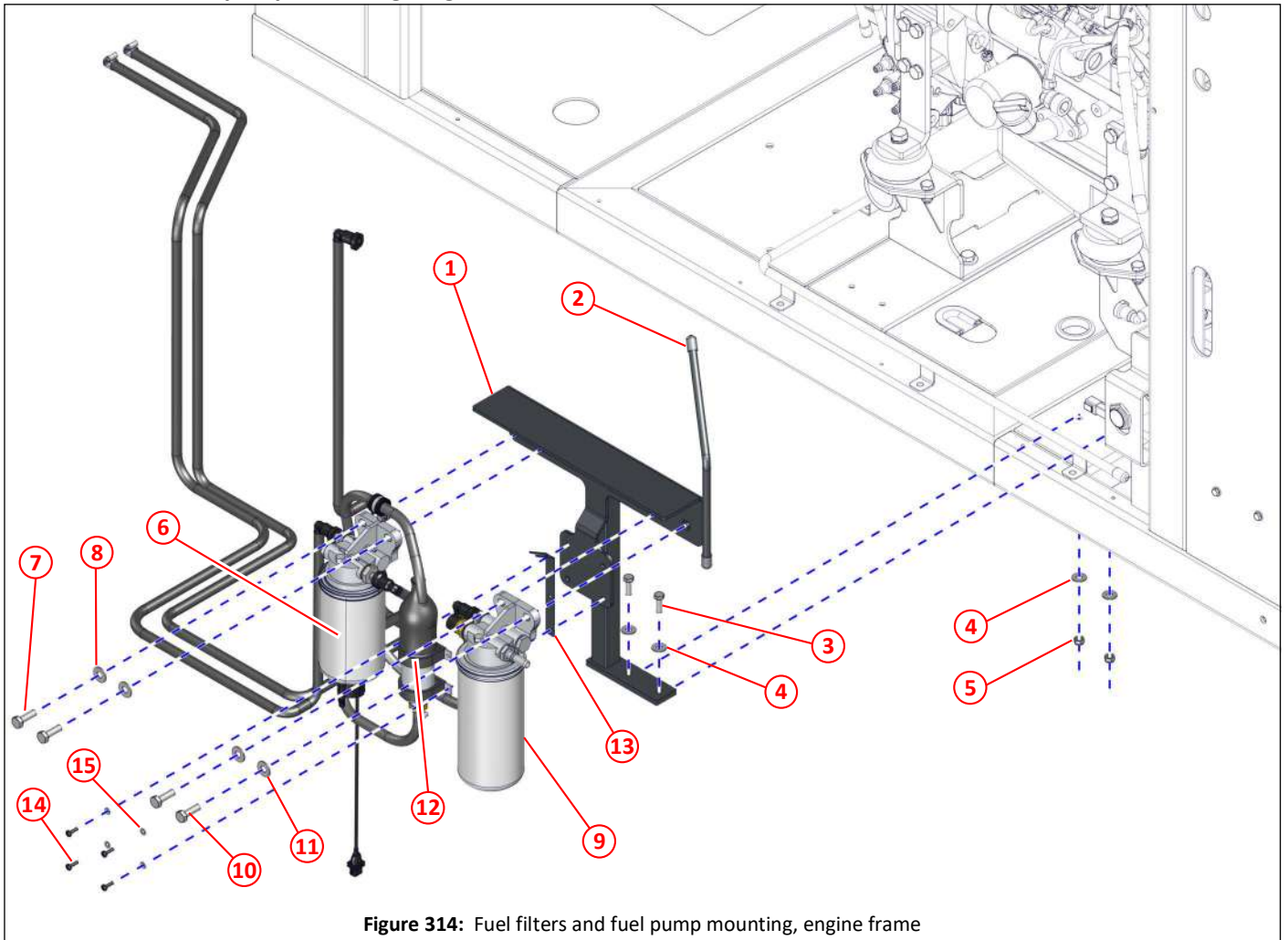

Figure 314: Fuel filters and fuel pump mounting, engine frame

Item	Part No	Qty	Description	
①	042955	1	Mounting bracket, fuel filters and fuel pump	
②	043065	2	Pipe cap, $\phi 12$	
③	011011	2	Set screw M8 x 25	
④	011092	4	Plain washer M8	
⑤	011073	2	Nyloc nut M8	
⑥	041699	1	Fuel filter, primary, assembly	433
⑦	011032	2	Set screw M10 x 30	
⑧	011094	2	Plain washer M10	
⑨	043035	1	Fuel filter, secondary, assembly	433
⑩	011032	2	Set screw M10 x 30	
⑪	011094	2	Plain washer M10	
⑫	043370	1	Fuel pump, 24v	433
⑬	044515	1	Fuel pump, 12v	433
⑭	043193	1	Bracket, fuel filter connector	
⑮	000234	4	Pan head Pozidrive screw M5 x 16, black	
⑯	000410	4	Plain washer M5	

Hopper raised sensor, engine frame

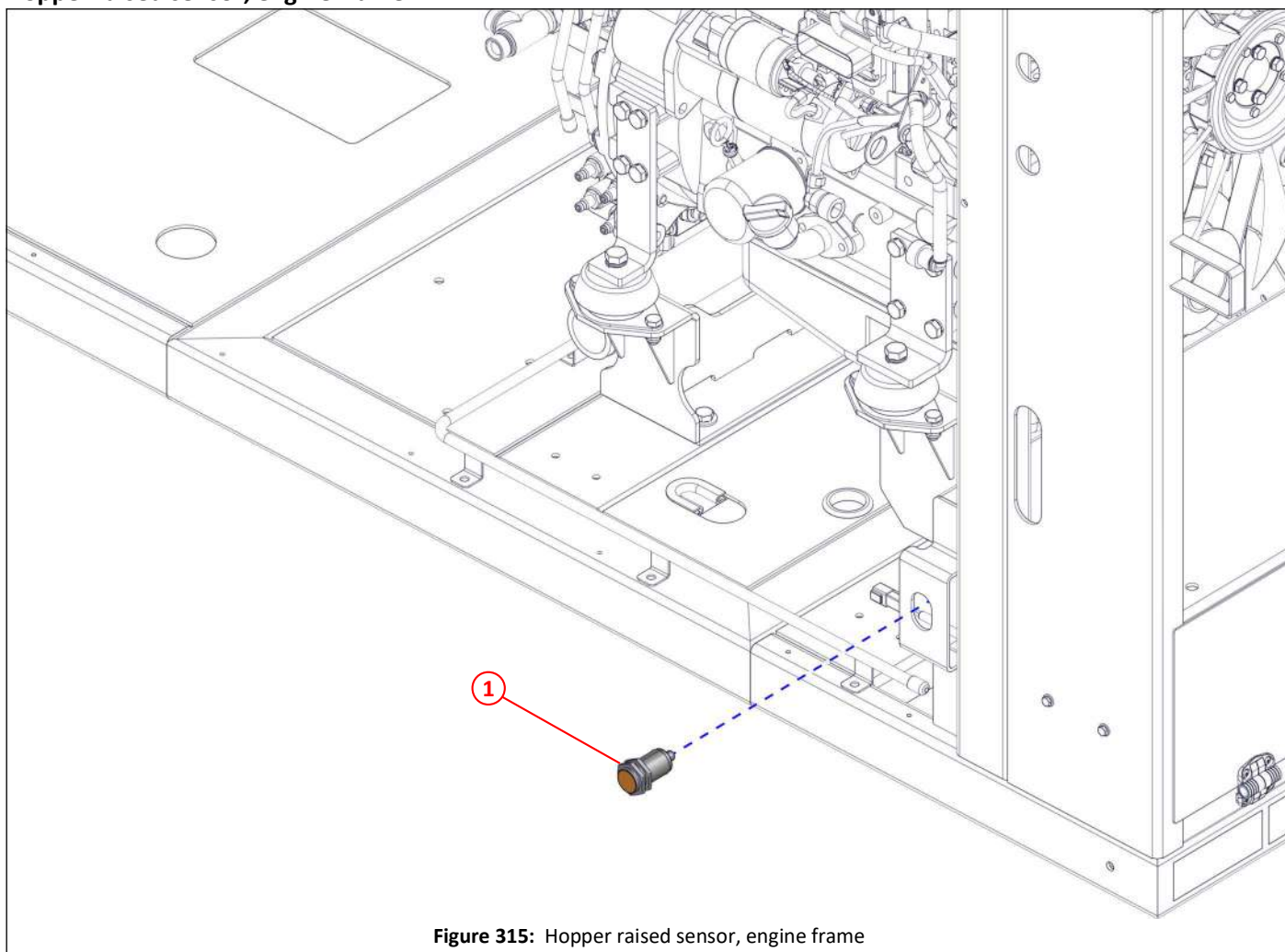

Figure 315: Hopper raised sensor, engine frame

Item	Part No	Qty	Description	
①	032627	1	Hopper raised proximity sensor	331
NI	043346	1	Loom, Node 4	



Work light, engine frame

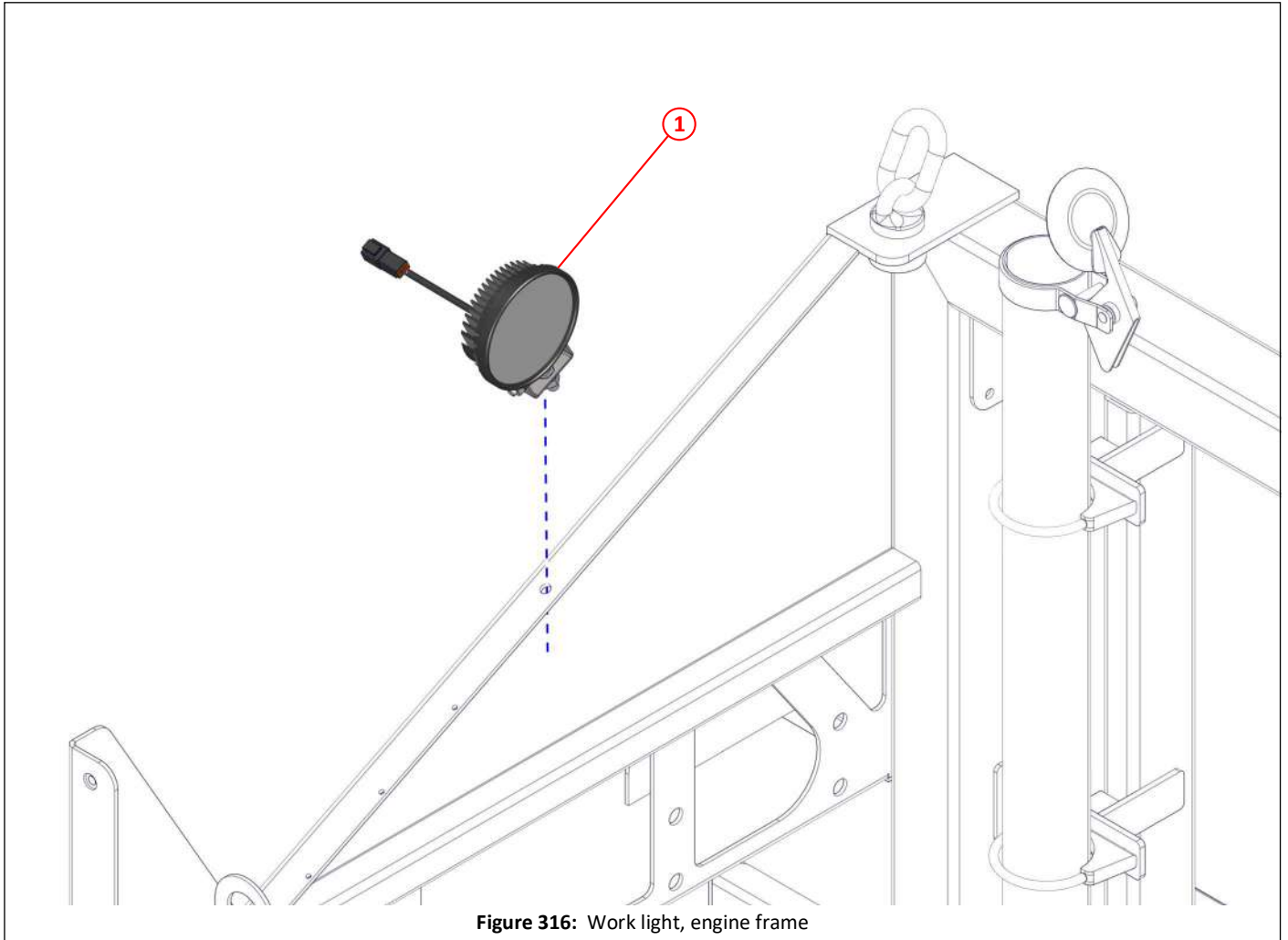

Figure 316: Work light, engine frame

Item	Part No	Qty	Description	
①	047757	1	Work light, 12/24v	328
NI	043348	1	Loom, Node 5	328,330
NI	043719	1	Loom, gantry work light	328,330

Exhaust stack mounting, engine frame

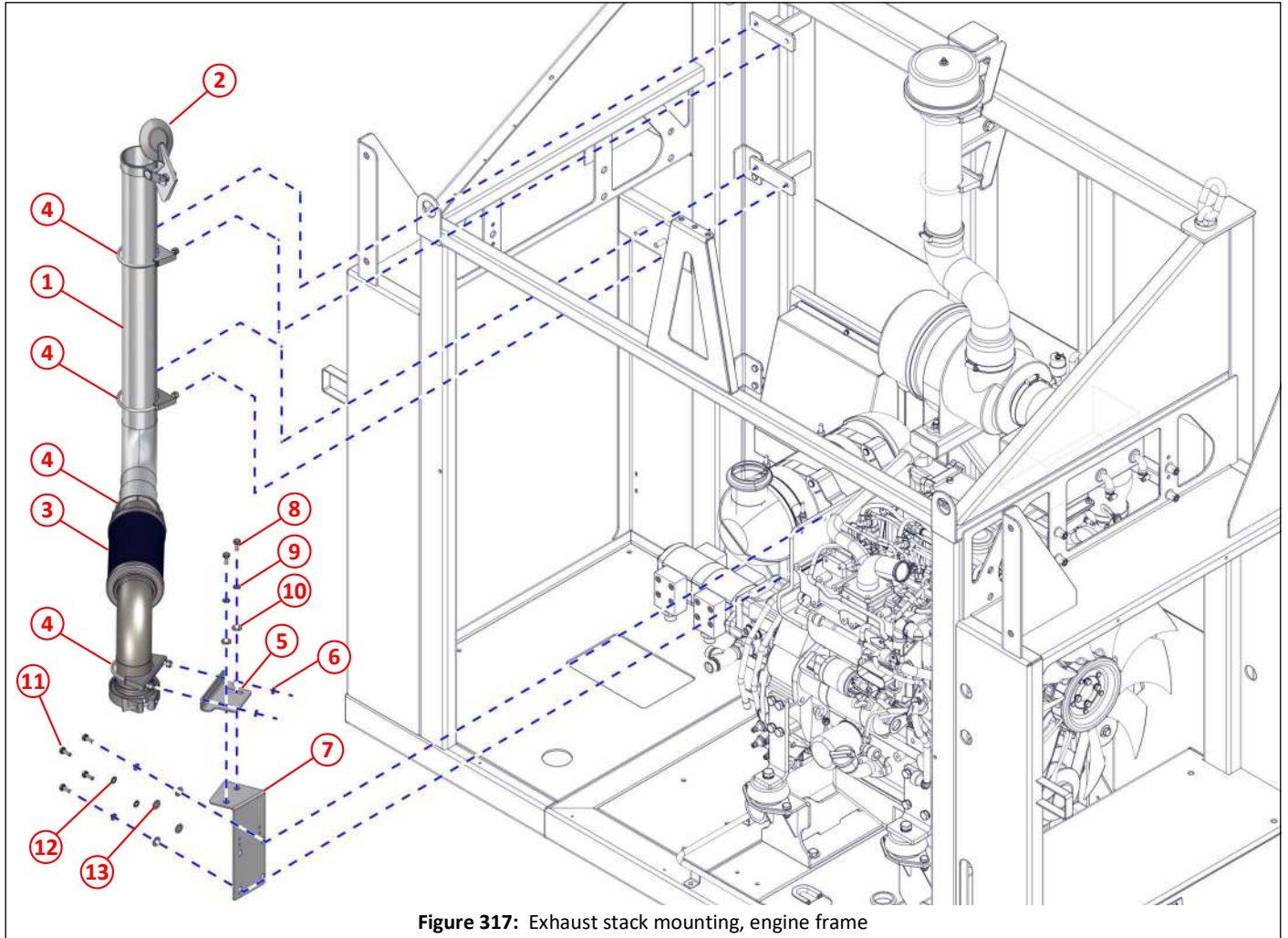

Figure 317: Exhaust stack mounting, engine frame

Item	Part No	Qty	Description	
①	043342	1	Exhaust stack	434
②	041907	1	Exhaust rain cap	434
③	043338	1	Exhaust elbow with flexible section	434
④	036831	4	U-clamp, exhaust, $\varnothing 83$	
⑤	043940	1	Bracket, U-clamp, exhaust	434
⑥	011093	2	Spring washer M8	
⑦	043339	1	Bracket, exhaust elbow	434
⑧	011010	2	Set screw M8 x 20	
⑨	011093	2	Spring washer M8	
⑩	011092	2	Plain washer M8	
⑪	011010	4	Set screw M8 x 20	
⑫	011093	4	Spring washer M8	
⑬	011092	4	Plain washer M8	



Air intake stack mounting, engine frame

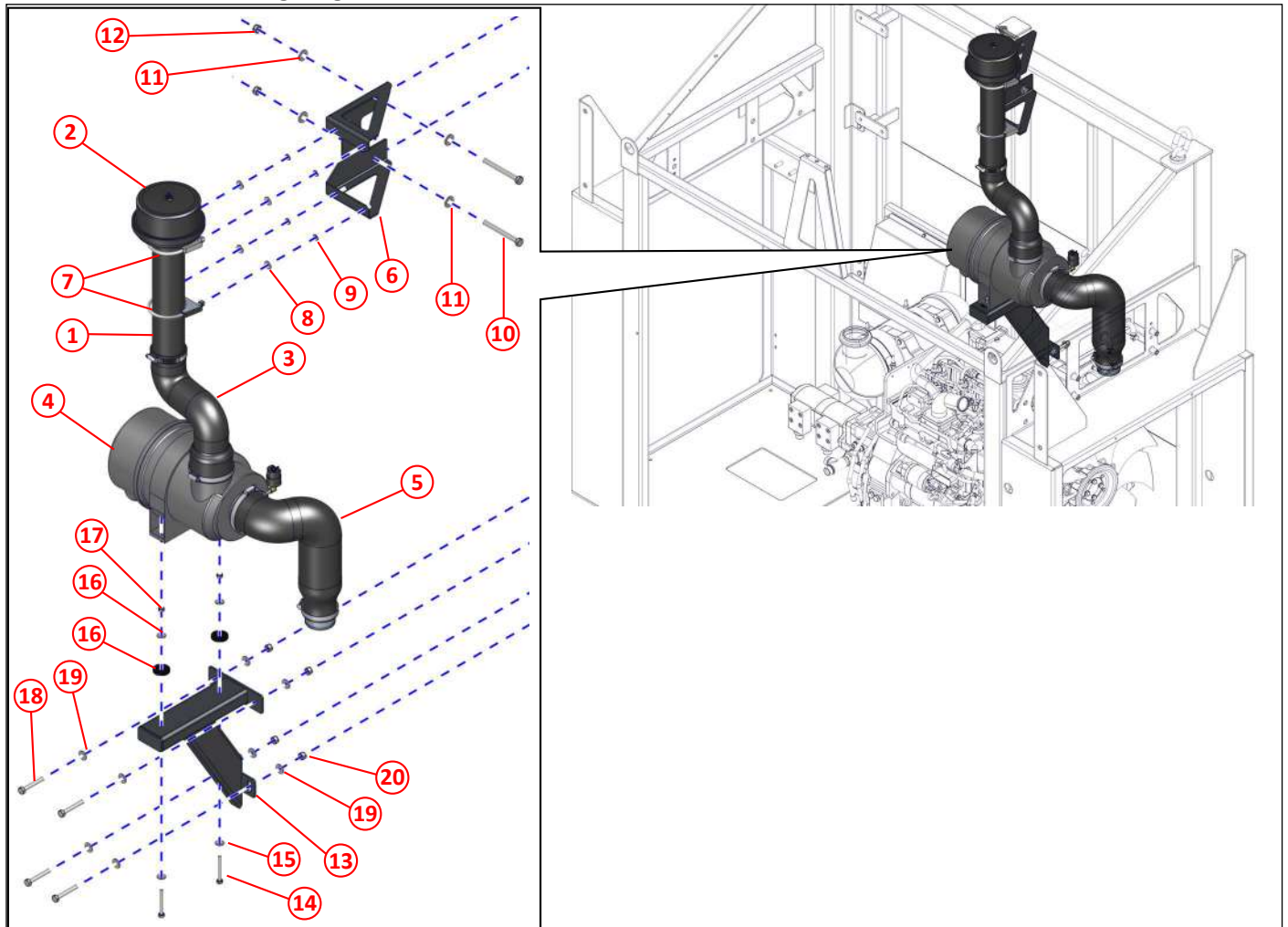

Figure 318: Air intake stack mounting, engine frame

Item	Part No	Qty	Description	
①	042915	1	Air intake stake	435
②	036022	1	Cap, pre-cleaner, air intake stack	435
③	042999	1	Hose B, air inlet	435
④	025279	1	Air cleaner assembly	435
⑤	042812	1	Hose A, air inlet	435
⑥	042946	1	Mounting bracket, air intake stack	435
⑦	036831	2	U-clamp $\varnothing 83$	
⑧	011092	4	Plain washer M8	
⑨	011093	4	Spring washer M8	
⑩	011064	2	Bolt M12 x 110	
⑪	011096	4	Plain washer M12	
⑫	011077	2	Nyloc nut M12	
⑬	042920	1	Mounting bracket, air cleaner	435
⑭	011018	2	Bolt M8 x 70	
⑮	011092	4	Plain washer M8	
⑯	012969	2	Washer, rubber, $\varnothing 12 \times \varnothing 40 \times 6$	
⑰	011073	2	Nyloc nut M8	
⑱	011037	4	Bolt M10 x 65	
⑲	011094	8	Plain washer N10	
⑳	011075	4	Nyloc nut M10	

Flow control valve block and hydraulic manifold mountings, engine frame

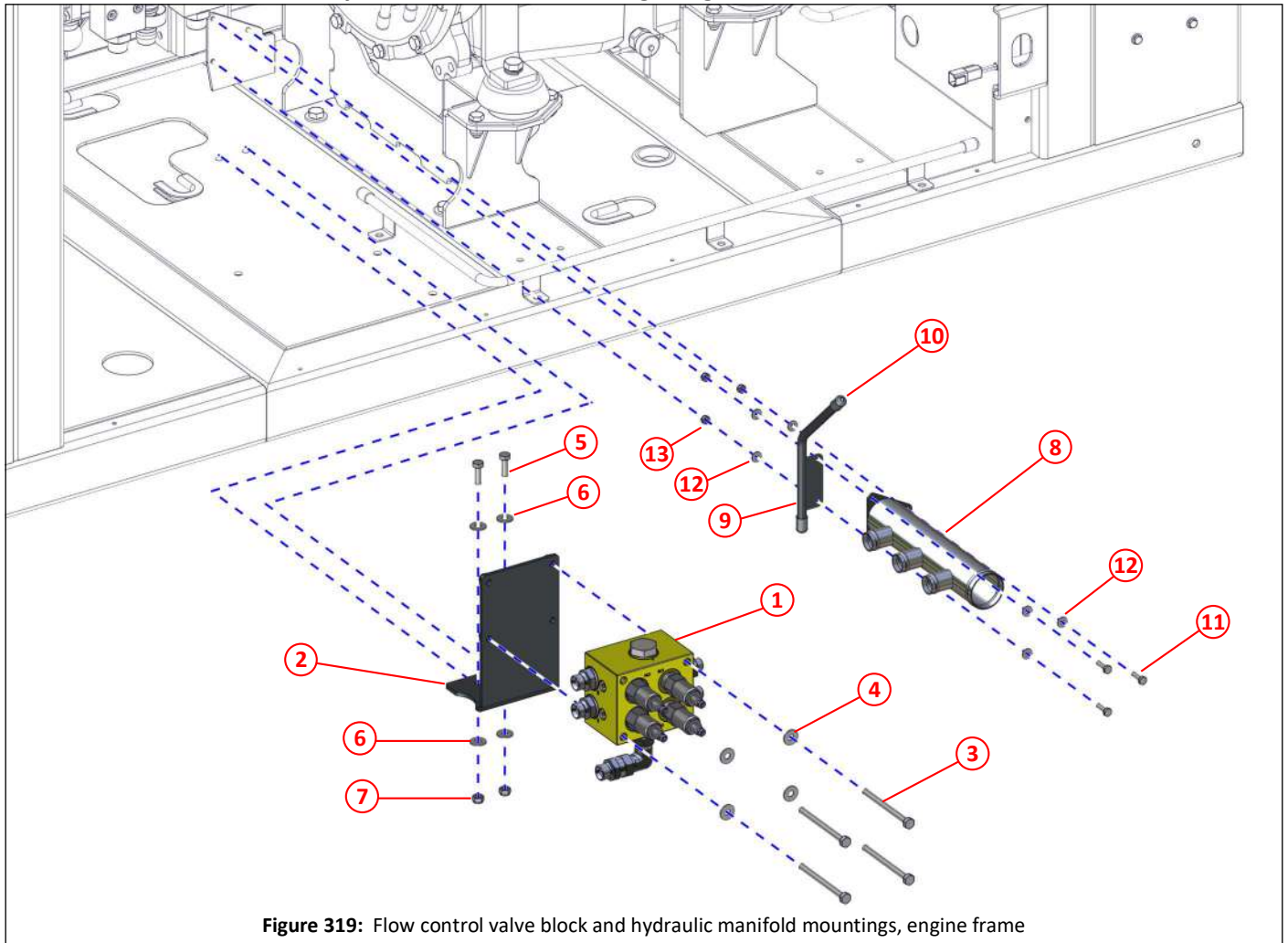

Figure 319: Flow control valve block and hydraulic manifold mountings, engine frame

Item	Part No	Qty	Description	
①	038513	1	Flow control valve block assembly	255
②	043123	1	Mounting bracket, flow control valve block	
③	011020	4	Bolt M8 x 100	
④	011092	4	Plain washer M8	
⑤	011011	2	Set screw M8 x 25	
⑥	011092	4	Plain washer M8	
⑦	011073	2	Nyloc nut M8	
⑧	043305	1	Manifold, hydraulic oil return	251
⑨	043362	1	Bracket, loom rail	
⑩	043065	2	Pipe cap, ø12	
⑪	011067	3	Set screw M6 x 20	
⑫	011090	6	Plain washer M6	
⑬	011071	3	Nyloc nut M6	

## Engine cradle and mounts, rear, engine frame

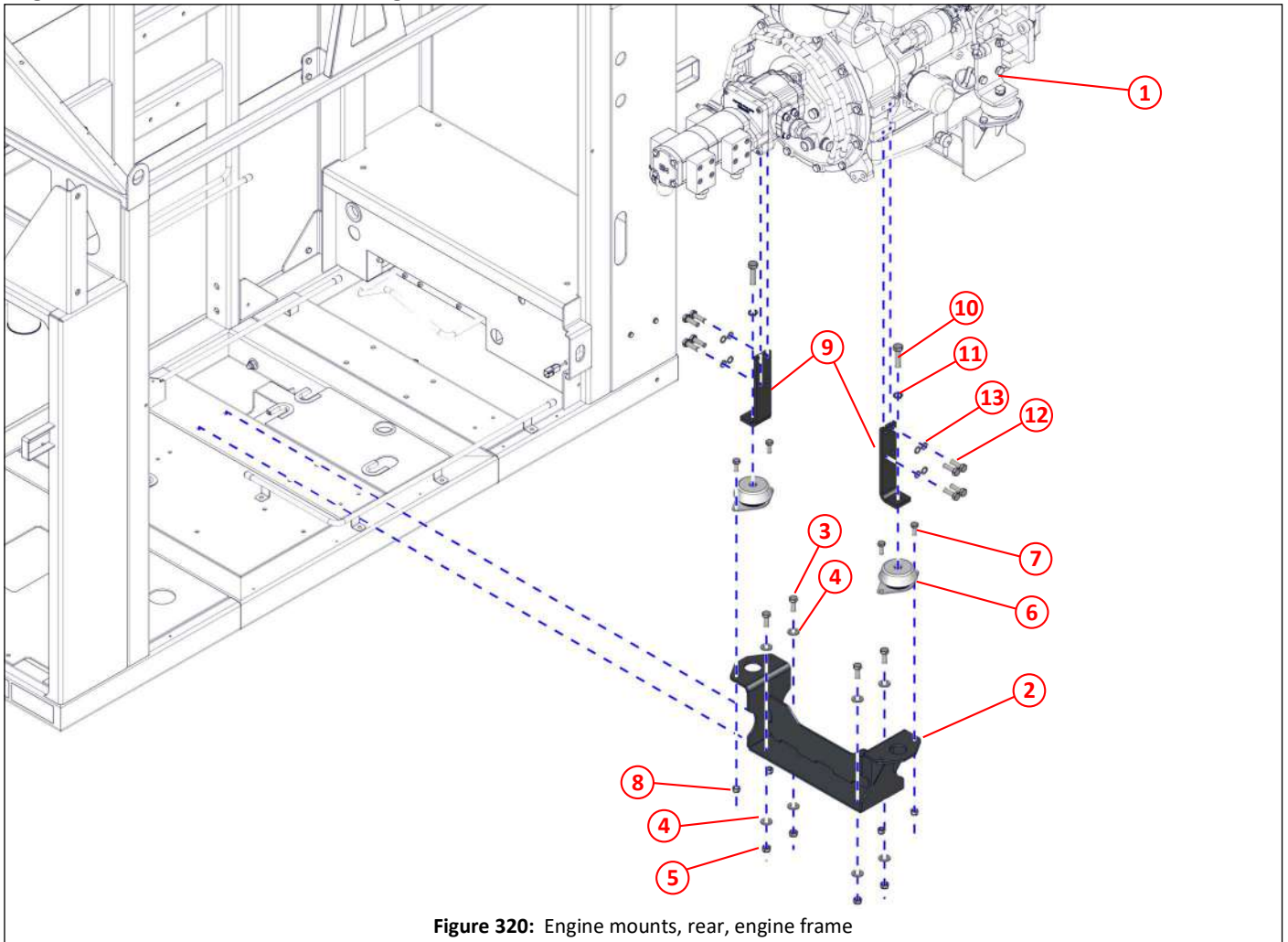

Figure 320: Engine mounts, rear, engine frame

Item	Part No	Qty	Description	
①		1	Engine, Deutz TCD 3.6 L4	424
②	042810	1	Engine cradle, rear	424
③	011052	4	Set screw M12 X 30	
④	011096	8	Plain washer M12	
⑤	011077	4	Nyloc nut M12	
⑥	030724	2	Engine mount	425
⑦	011031	4	Set screw M10 x 25	
⑧	011075	4	Nyloc nut M10	
⑨	042811	2	Engine mounting, rear	426
⑩	011403	2	Bolt M14 x 50	
⑪	011106	2	Spring washer M14	
⑫	011053	8	Set screw M12 x 35	
⑬	011097	8	Spring washer M12	

## Engine cradle and mounts, front, engine frame

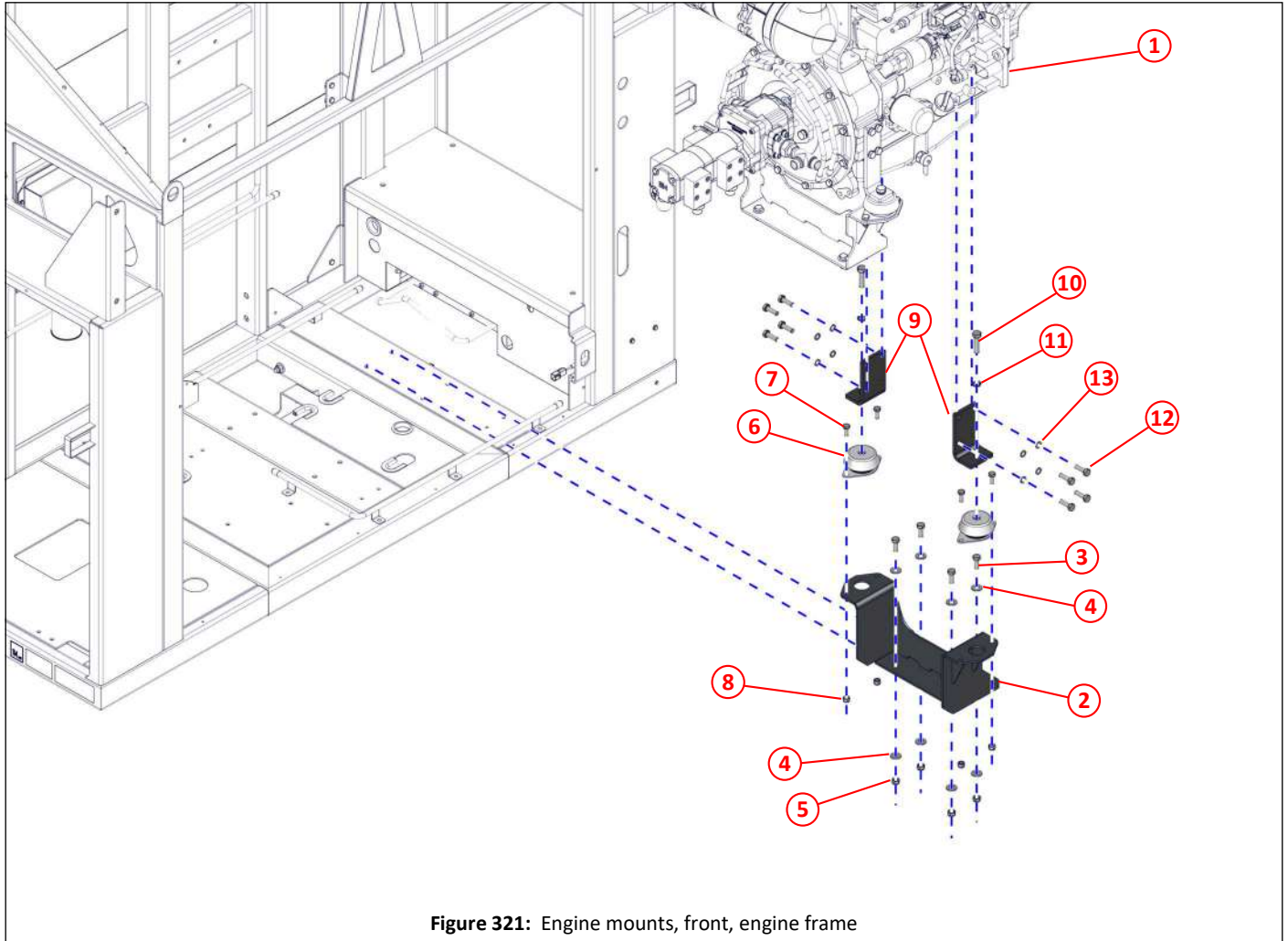

Figure 321: Engine mounts, front, engine frame

Item	Part No	Qty	Description	
①		1	Engine, Deutz TCD 3.6 L4	424
②	042809	1	Engine cradle, front	424
③	011052	4	Set screw M12 X 30	
④	011096	8	Plain washer M12	
⑤	011077	4	Nyloc nut M12	
⑥	030724	2	Engine mount	425
⑦	011031	4	Set screw M10 x 25	
⑧	011075	4	Nyloc nut M10	
⑨	042808	2	Engine mounting, front	426
⑩	011403	2	Bolt M14 x 50	
⑪	011106	2	Spring washer M14	
⑫	011053	8	Set screw M12 x 35	
⑬	011097	8	Spring washer M12	



Expansion tank mounting, engine frame

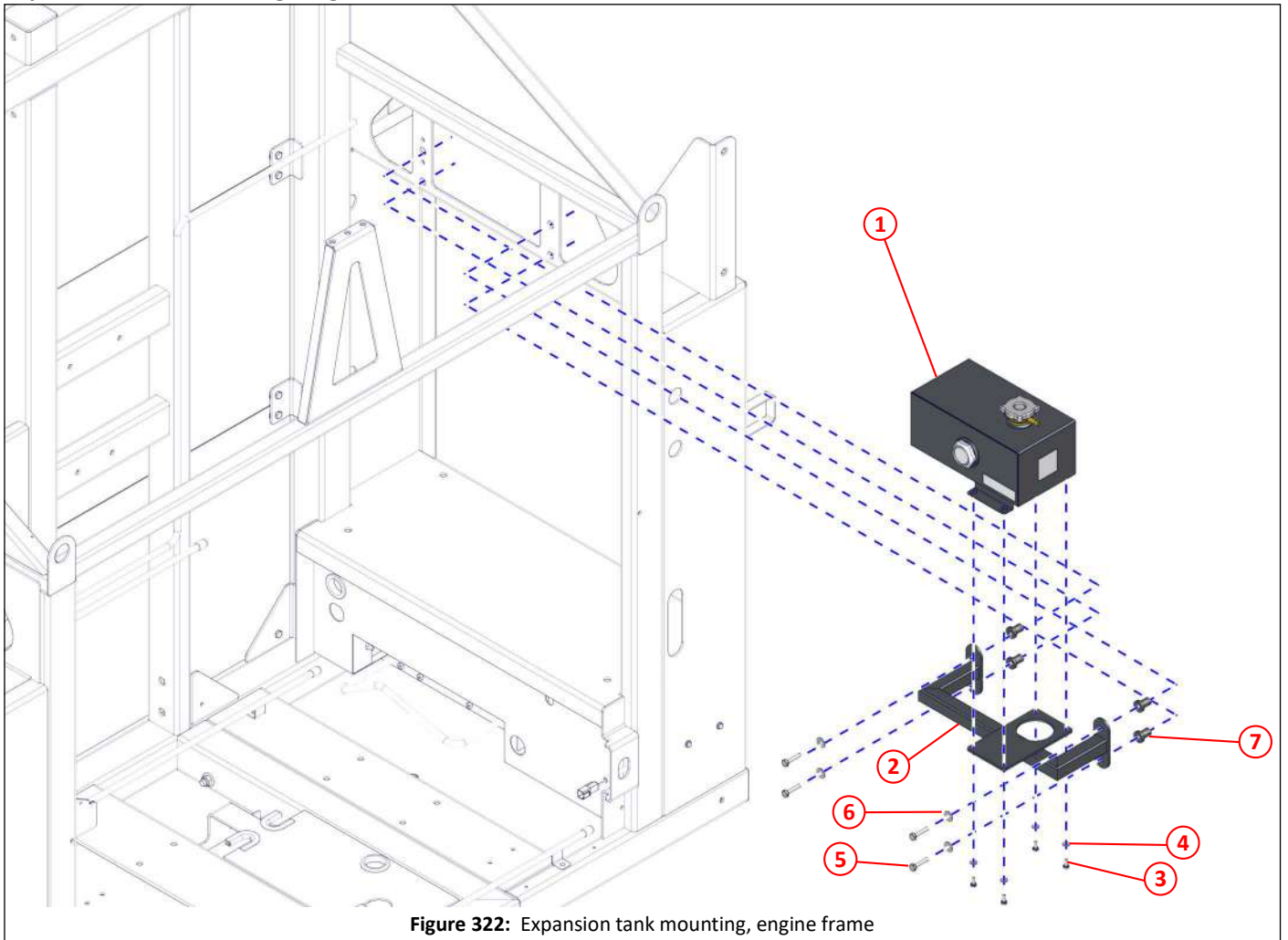

Figure 322: Expansion tank mounting, engine frame

Item	Part No	Qty	Description	
①	041936	1	Expansion tank	436
②	042989	1	Mounting bracket, expansion tank	436
③	011001	4	Set screw M6 x 16	
④	011090	4	Plain washer M6	
⑤	011013	4	Set screw M8 x 35	
⑥	011092	4	Plain washer M8	
⑦	039932	4	Anti-vibration fastener M8	

## ECU cover mounting, engine frame

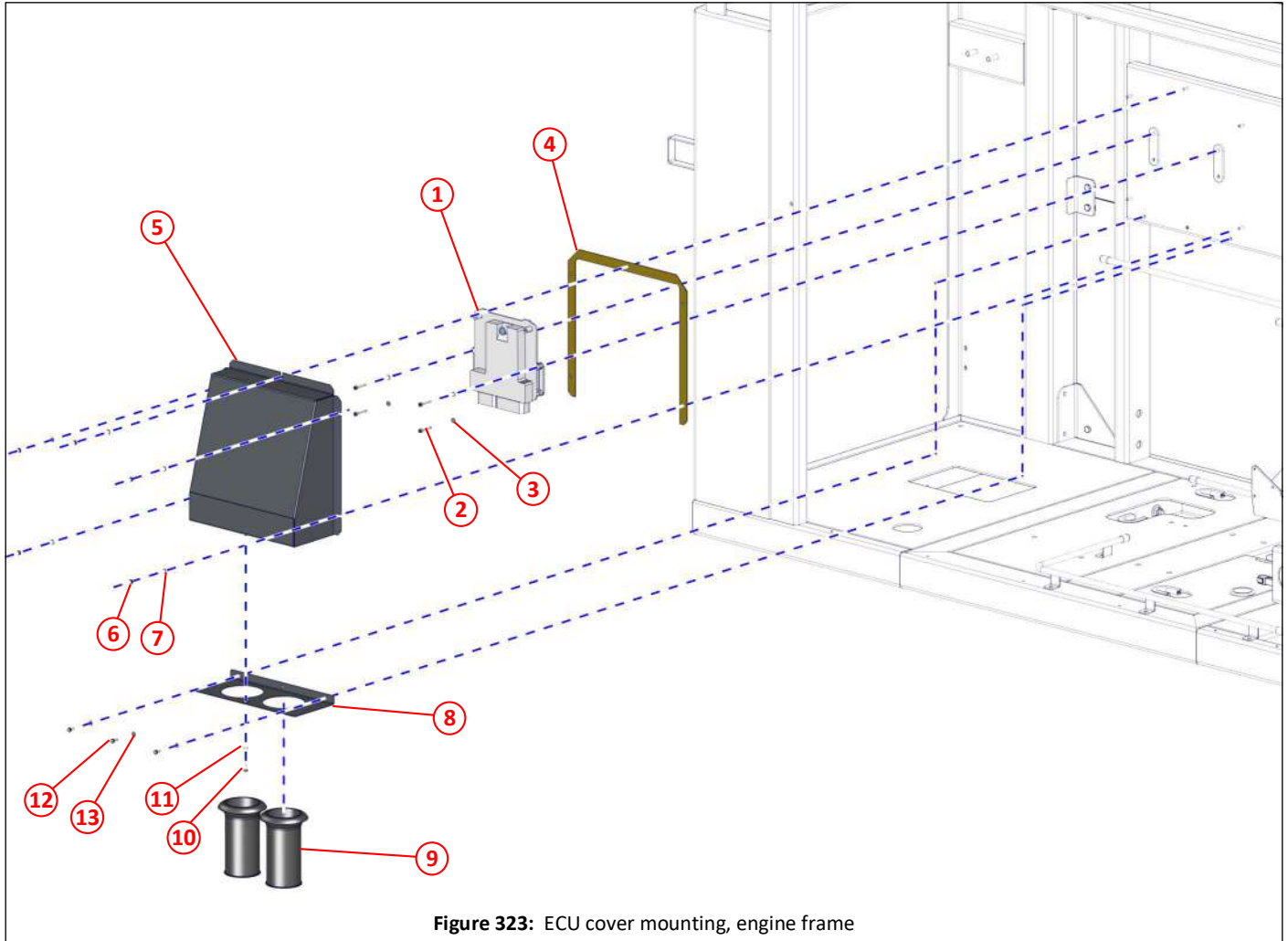

Figure 323: ECU cover mounting, engine frame

Item	Part No	Qty	Description	
①	044500 *	1	ECU	432
②	000118	4	Socket cap head screw M5 x 30	
③	000410	4	Plain washer M5	
④	042982	1	Gasket, ECU cover	
⑤	042981	1	Cover, ECU	
⑥	000155	5	Nyloc nut M5	
⑦	000410	5	Plain washer M5	
⑧	044302	1	Mount, panel sock	
⑨	034807	2	Panel sock	
⑩	000097	1	Bolt M5 x 12	
⑪	000410	1	Plain washer M5	
⑫	000097	3	Bolt M5 x 12	
⑬	000410	3	Plain washer M5	

\*. The ECU will need to be matched to the serial number of the DEUTZ auxiliary engine of your vehicle.



Hydraulic cabinet door fittings, engine frame

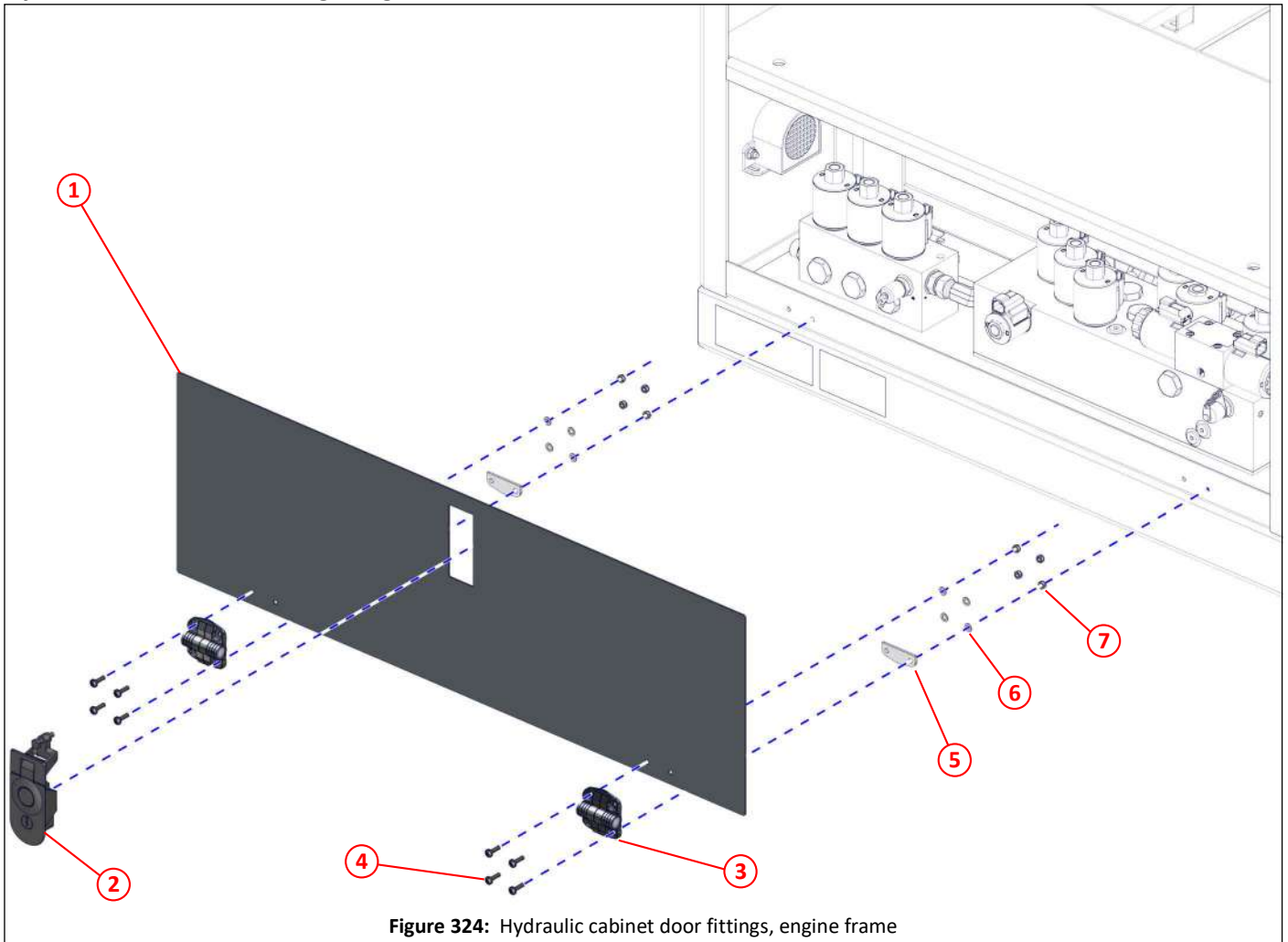

Figure 324: Hydraulic cabinet door fittings, engine frame

Item	Part No	Qty	Description	
①	043078	1	Door, hydraulic cabinet	
②	033634	1	Latch, sealed, locking	
③	027193	2	Hinge	
④	000234	8	Pan head Pozidrive screw M5 x 16, black	
⑤	028320	2	Packer, hinge	
⑥	000410	8	Plain washer M5	
⑦	000155	8	Nyloc nut M5	

Hydraulic cabinet valve block fittings, engine frame

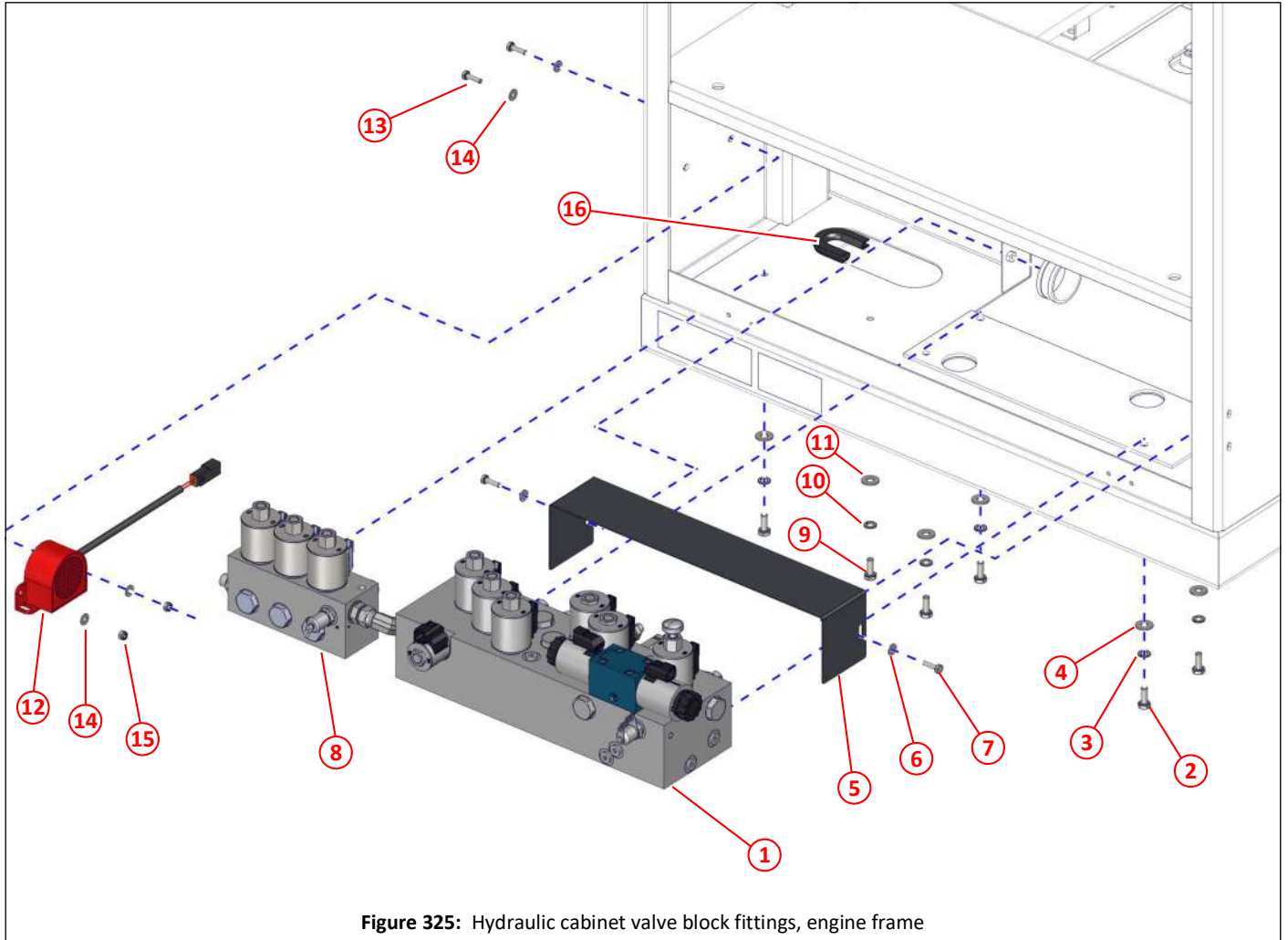

Figure 325: Hydraulic cabinet valve block fittings, engine frame

Item	Part No	Qty	Description	
①	042615	1	Main valve block, 24v	262,263,265
①	044484	1	Main valve block, 12v	262,263,265
②	011010	4	Set screw M8 x 20	
③	011093	4	Spring washer M8	
④	011092	4	Plain washer M8	
⑤	034810	1	Pipe cover	
⑥	011067	2	Set screw M6 x 20	
⑦	011090	2	Plain washer M6	
⑧	042616	1	Options valve block, 24v	262,266,267
⑧	044486	1	Options valve block, 12v	262,266,267
⑨	011010	2	Set screw M8 x 20	
⑩	011093	2	Spring washer M8	
⑪	011092	2	Plain washer M8	
⑫	037666	1	Sounder, hopper and rear door operation	
⑬	011067	2	Set screw M6 x 20	
⑭	011090	4	Plain washer M6	
⑮	011071	2	Nyloc nut M6	
⑯	005073	As req	Titanfast edging MET106 to suit 3-5mm	

End panels, engine frame

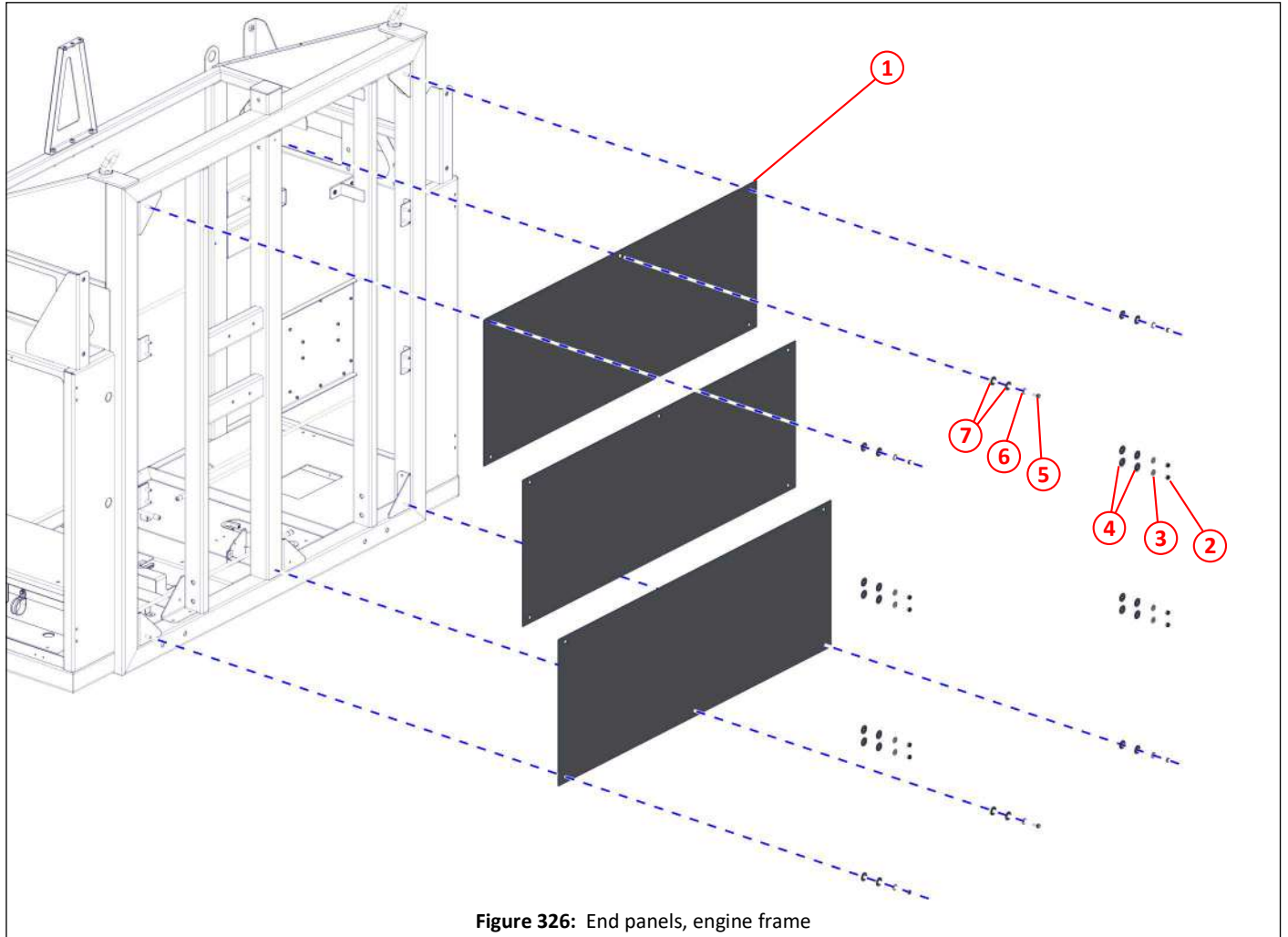

Figure 326: End panels, engine frame

Item	Part No	Qty	Description
①	044867 *	3	End panel
NI	034799 *	1	End panel, for version with just single large end panel
②	011073	12	Nyloc nut M8
③	011092	12	Plain washer M8
④	028646	24	Packing washer
⑤	011010	2	Set screw M8 x 20
⑥	011092	2	Plain washer M8
⑦	028646	4	Packing washer

\*. Early versions of M65T engine frame had a single large end panel.

Engine frame

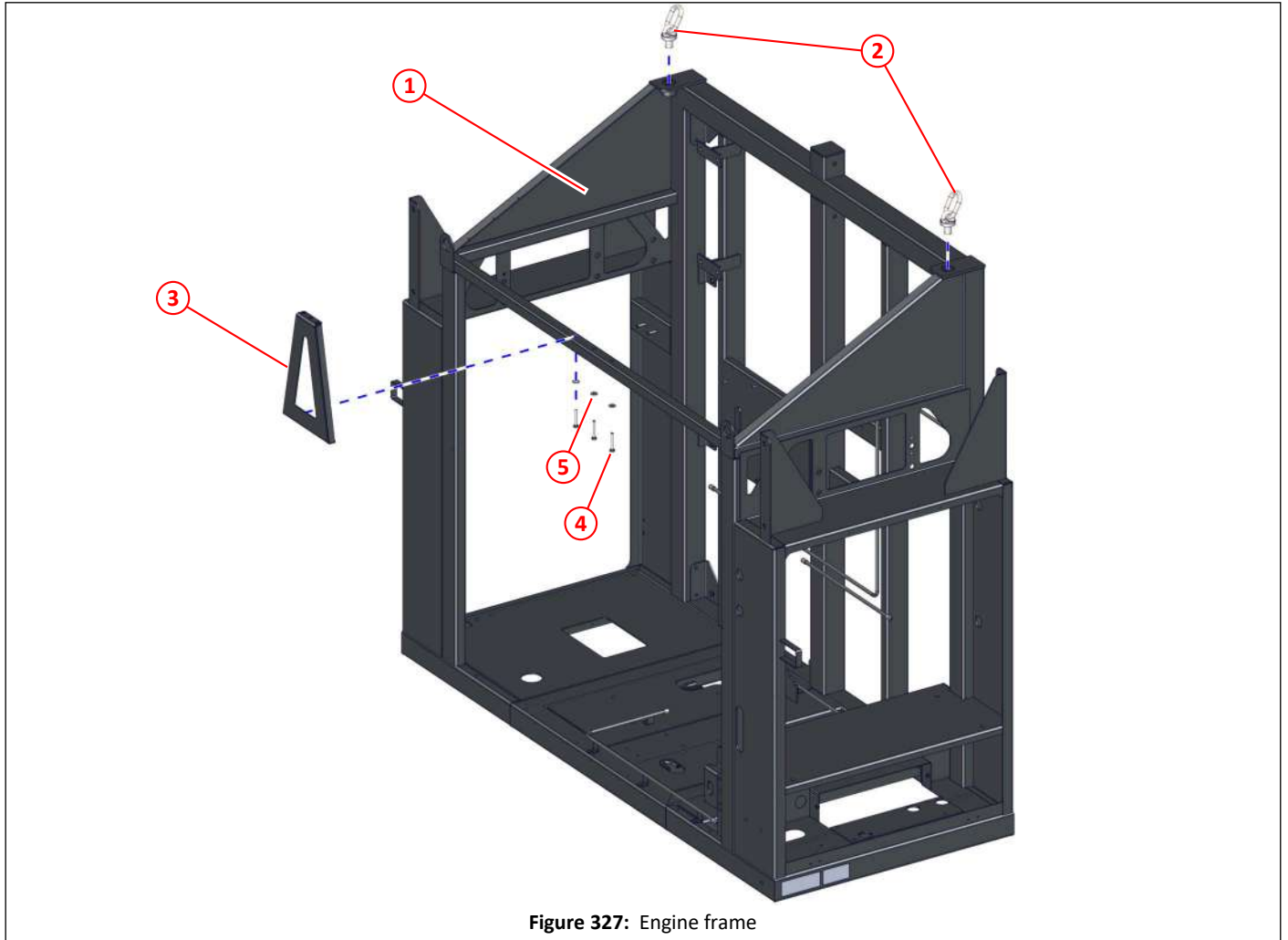

Figure 327: Engine frame

Item	Part No	Qty	Description	
①	042803	1	Engine frame	
②	035941	2	Eye bolt, linked, 1.6T	335
③	043153	1	Support, roof panel	336
④	000009	3	Bolt M8 X 55	
⑤	011092	3	Plain washer M8	
NI	005073	As req	Titanfast edging MET106 to suit 3-5mm	
NI	043065	As req	Pipe cap, ø12	

Subframe general arrangement

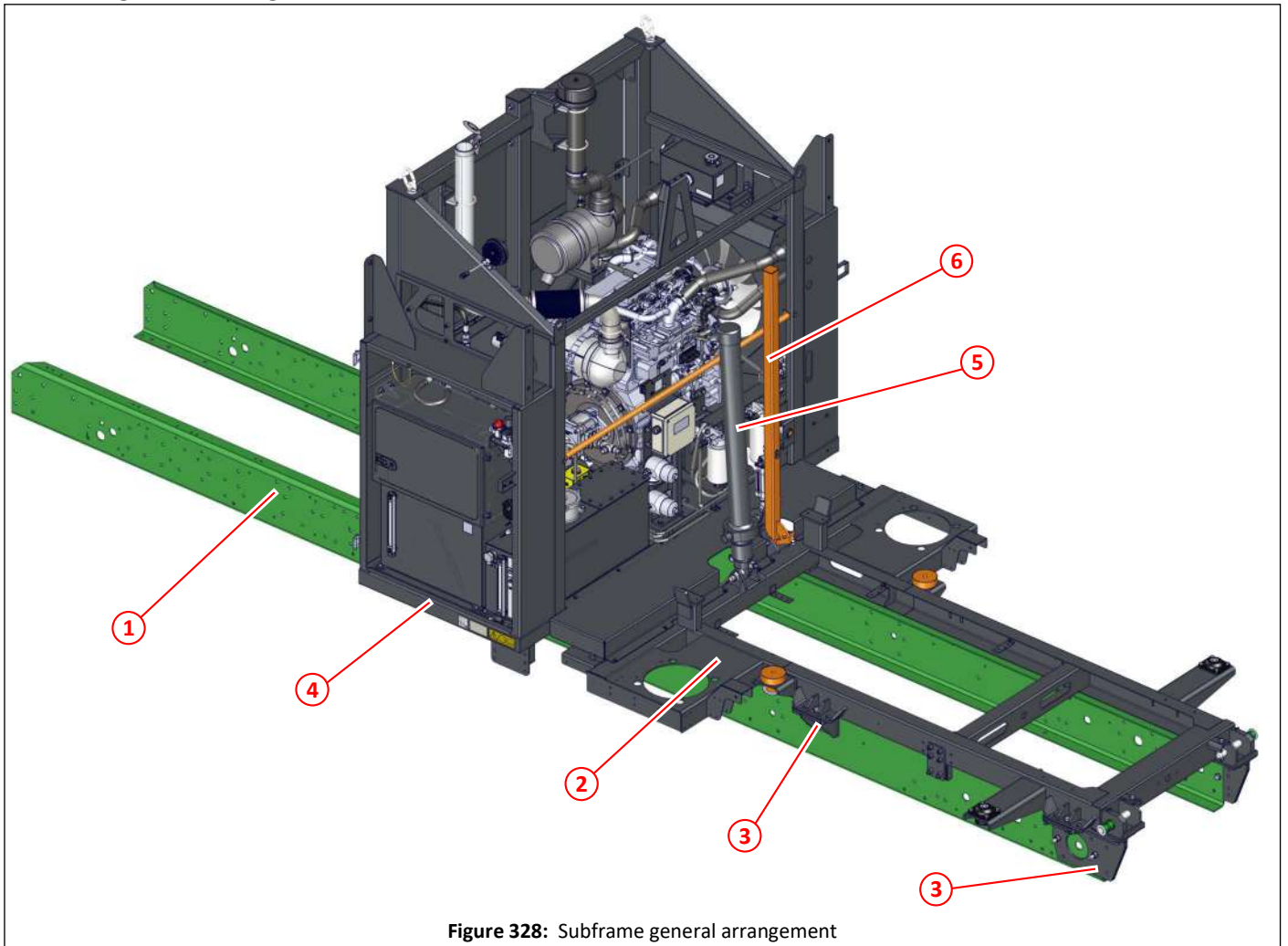

Figure 328: Subframe general arrangement

Item	Part No	Qty	Description	
①			Chassis rails, shown for visualisation only	
②	042942	1	Subframe	
③			Mounting brackets, chassis	373
④			Engine frame assembly	335
⑤	024249	1	Ram, dual acting, hopper lift	155,271
⑥	043391	1	Hopper safety prop	316,366,368



Subframe

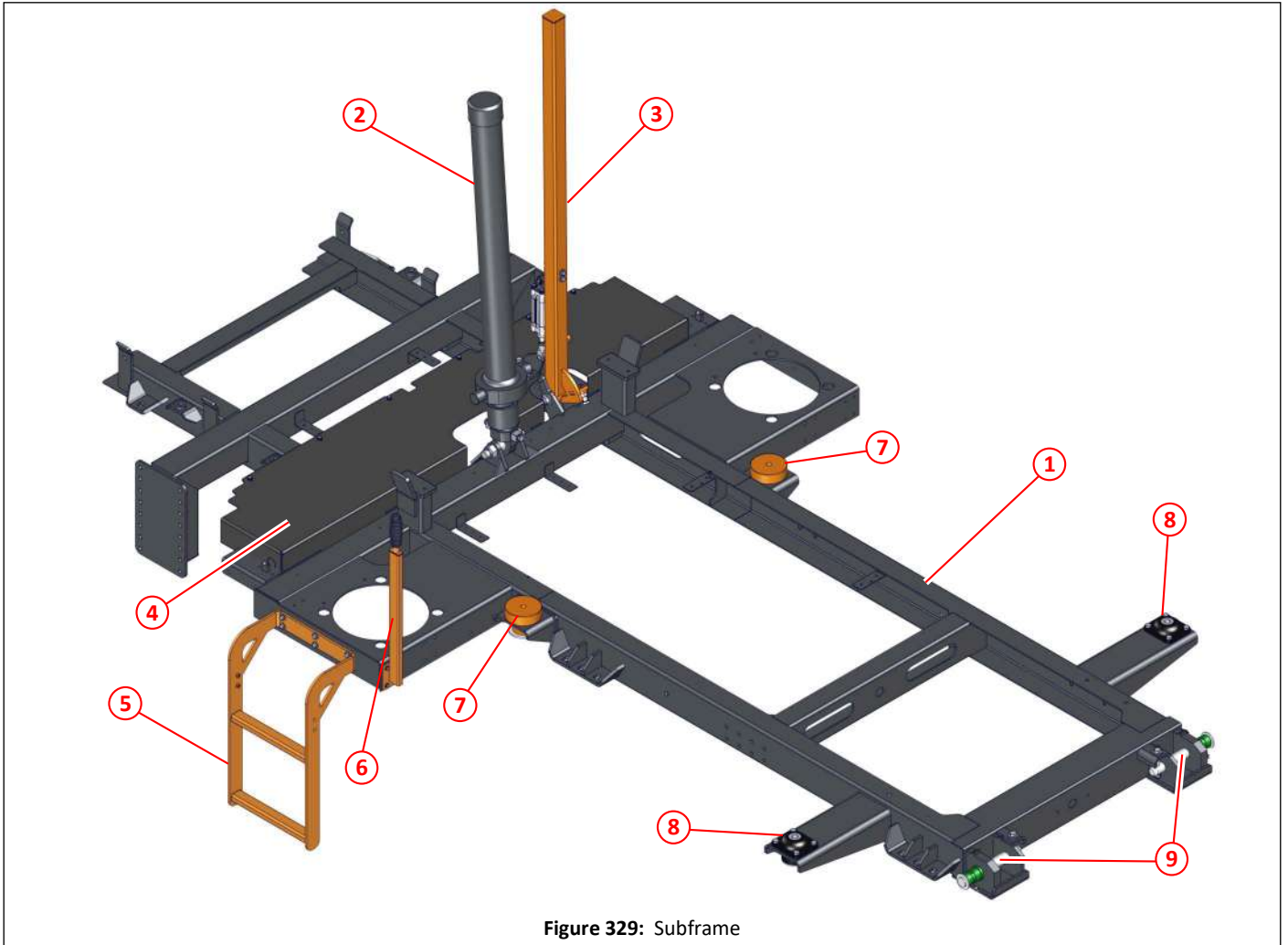

Figure 329: Subframe

Item	Part No	Qty	Description	
①	042942	1	Subframe	365,367,372
②	024249	1	Ram, dual acting, hopper lift	155,271,365
③	043391	1	Hopper safety prop	365
④	045289	1	Floor plate	369
⑤	034766	1	Access ladder	371
⑥	043608	1	Grab handle	371
⑦	044509	2	Bush, orange, water tank	199
⑧	033838	2	Mounting, anti-vibration, MS243/5 (HD type), water tank	199
⑨			Hopper pins and bushes	154



Subframe and pipe, hose and wiring support brackets

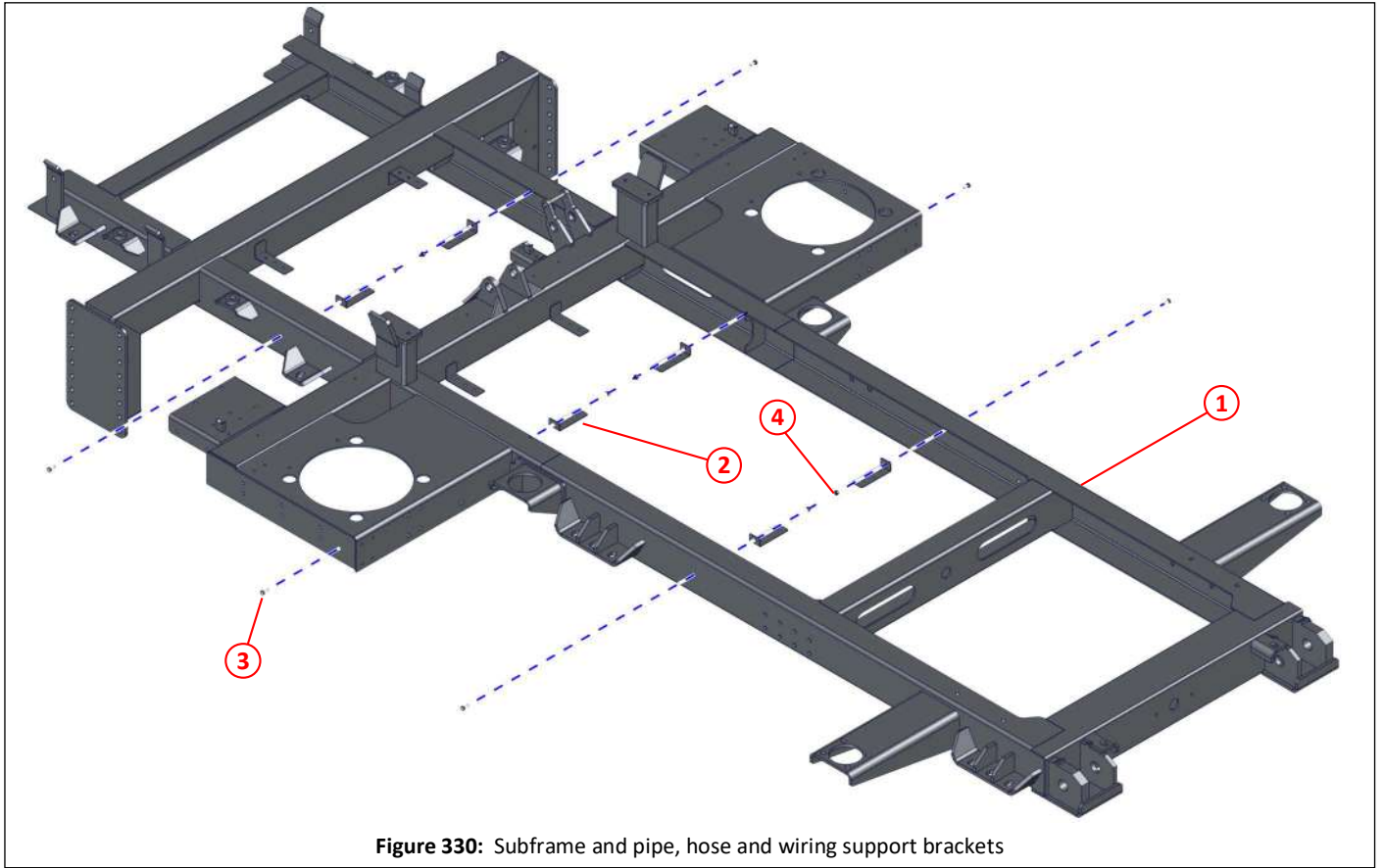

Figure 330: Subframe and pipe, hose and wiring support brackets

Item	Part No	Qty	Description	
①	042942	1	Subframe	365,366,372
②	028862	6	Bracket	
③	011001	6	Set screw M6 x 16	
④	011071	6	Nyloc nut M6	

Hopper safety prop

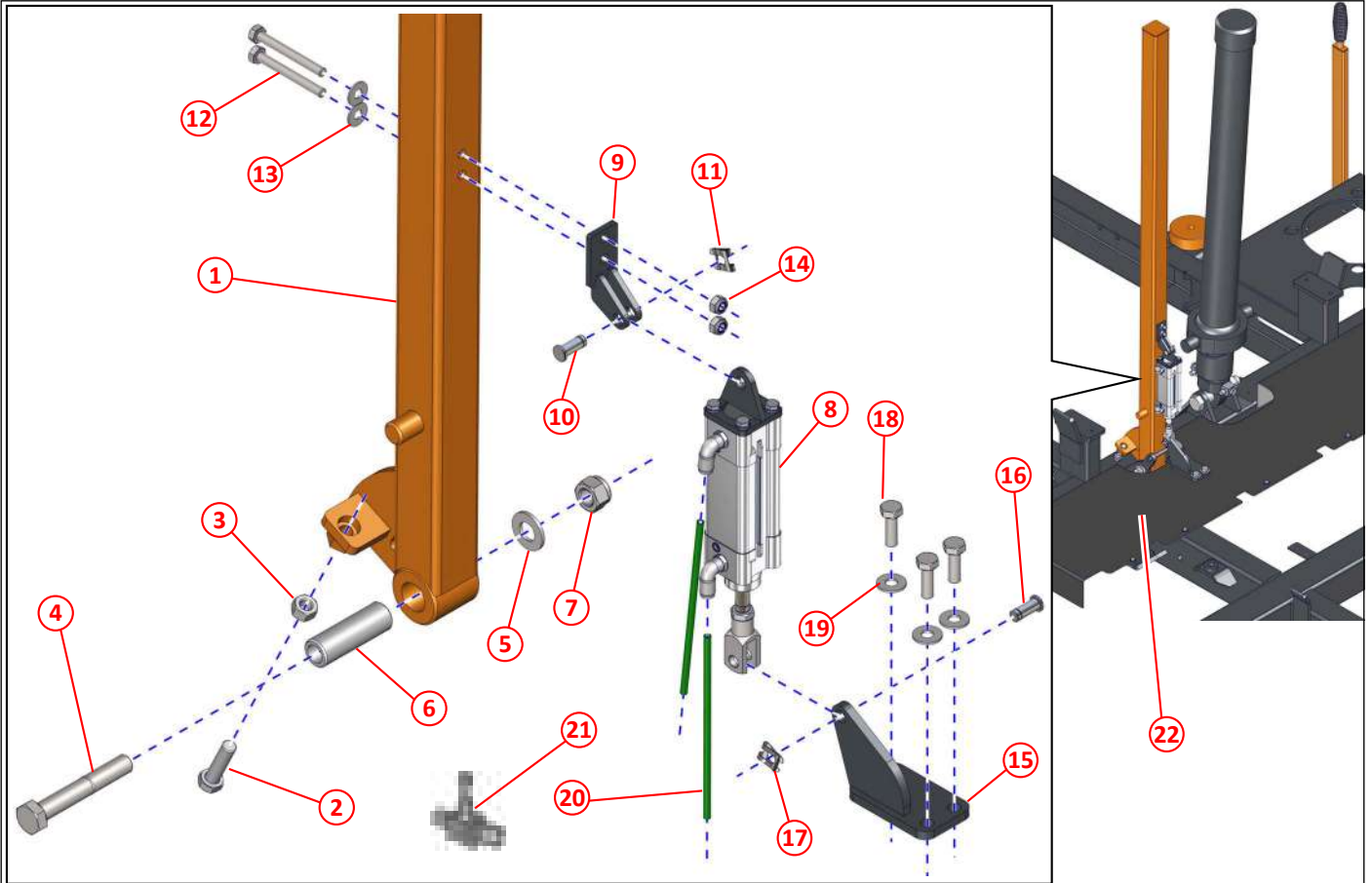

Figure 331: Hopper safety prop

Item	Part No	Qty	Description	
①	043391	1	Hopper safety prop	316,365,366
②	011054	1	Set screw M12 x 45	
③	011076	1	Full nut M12	
④	044483	1	Special bolt M16 x 95 (8.8 grade)	
⑤	011135	1	Plain washer M16	
⑥	036240	1	Spacer, hopper prop	
⑦	011060	1	Nyloc nut M16	
⑧	043175	1	Pneumatic cylinder, prop kicker	316
⑨	043390	1	Bracket, prop kicker	
⑩	026163	1	Clevis pin	
⑪	026164	1	Retaining clip	
⑫	011018	2	Bolt M8 x 70	
⑬	011092	2	Plain washer M8	
⑭	011073	2	Nyloc nut M8	
⑮	043364	1	Floor mount, prop kicker	
⑯	026163	1	Clevis pin	
⑰	026164	1	Retaining clip	
⑱	011032	3	Set screw M10 x 30	
⑲	011094	3	Plain washer M10	
⑳	024650	As req	Air pipe, green, ø6	
㉑	006062	2	In-line flow control valve (Mounted on subframe below hopper prop)	
㉒	045289	1	Floor plate	

Floor plate, subframe and engine frame

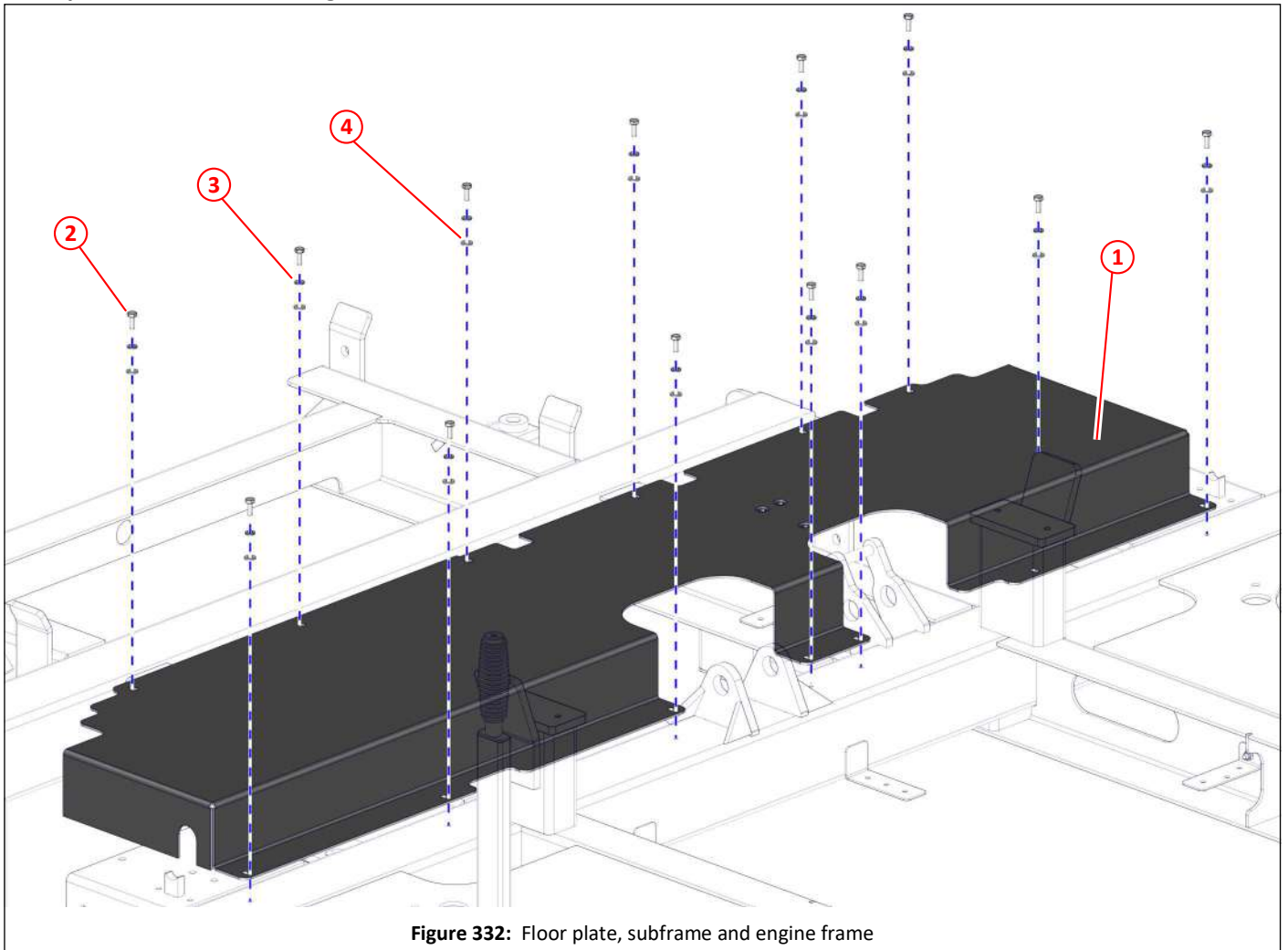

Figure 332: Floor plate, subframe and engine frame

Item	Part No	Qty	Description	
①	045289	1	Floor plate	366
②	011001	13	Set screw M6 x 16	
③	011091	13	Spring washer M6	
④	011090	13	Plain washer M6	

## Subframe hopper lift ram mounting

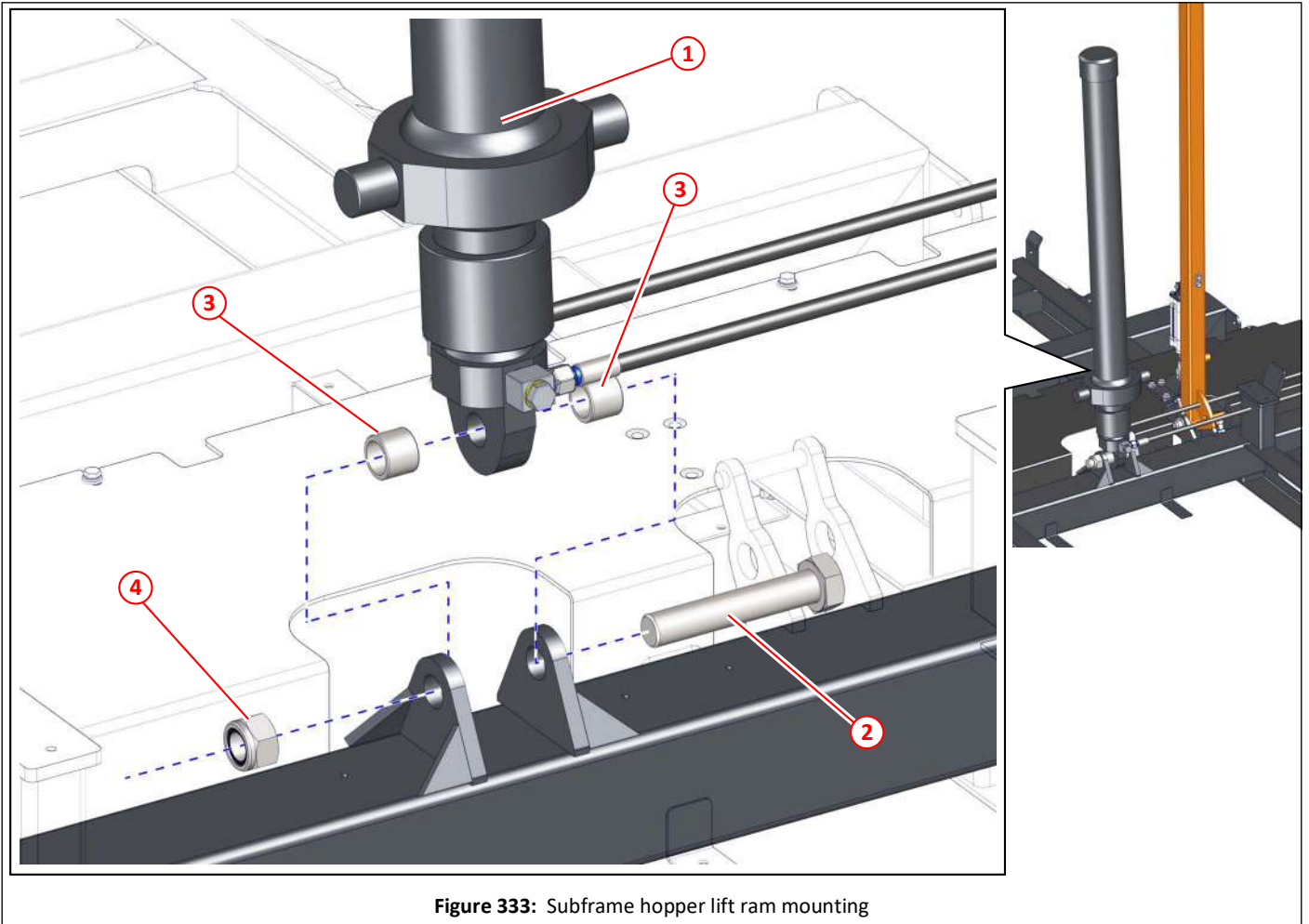
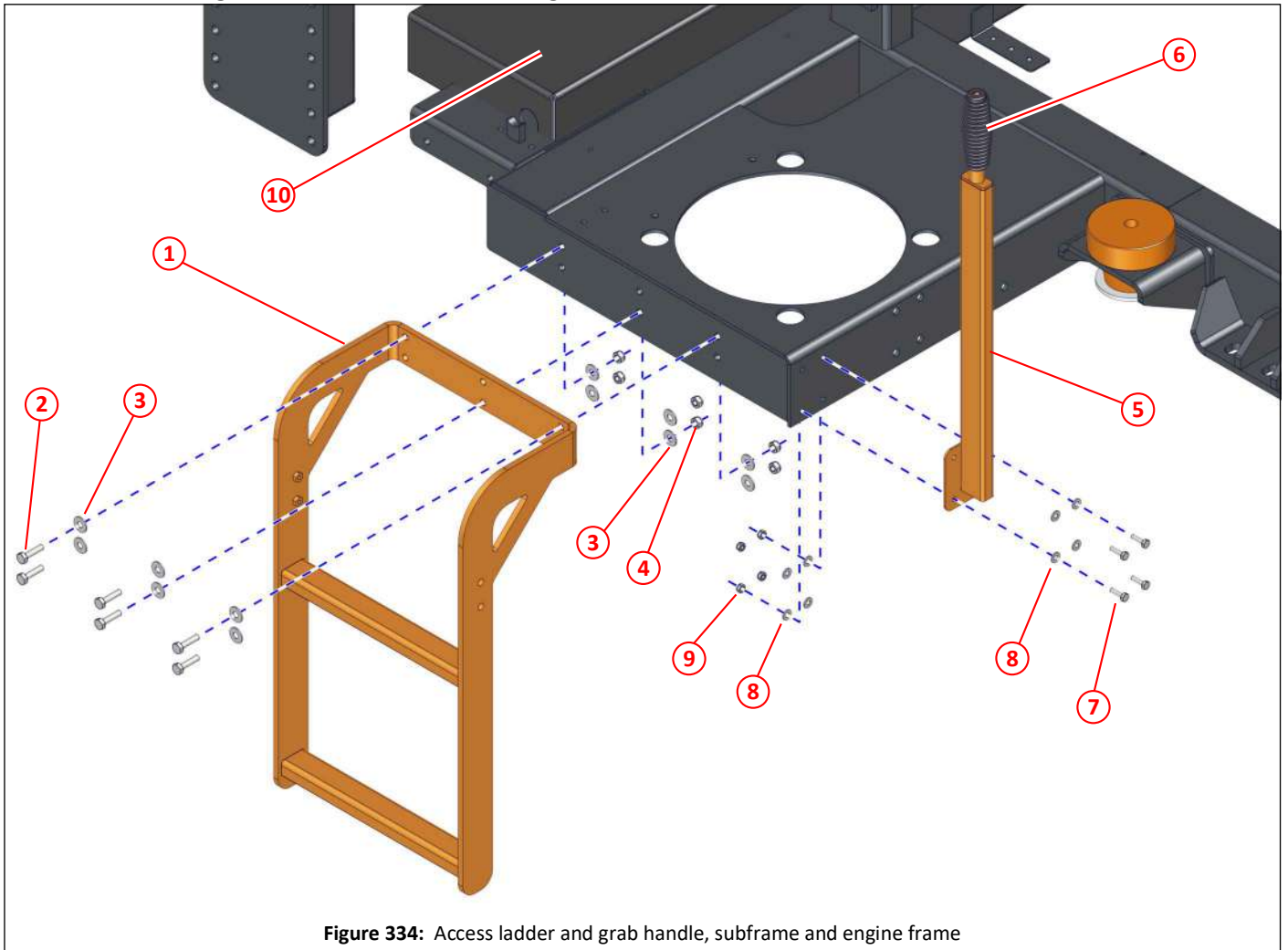

Figure 333: Subframe hopper lift ram mounting

Item	Part No	Qty	Description	
①	024249	1	Ram, dual acting, hopper lift	155,271,365,366
②	000241	1	Bolt M24 x 130	
③	013714	2	Spacer	
④	000008	1	Nyloc nut M24	

## Access ladder and grab handle, subframe and engine frame



**Figure 334:** Access ladder and grab handle, subframe and engine frame

Item	Part No	Qty	Description	
①	034766	1	Access ladder, subframe and engine frame	366
②	011012	6	Set screw M8 x 30	
③	011092	12	Plain washer M8	
④	011073	6	Nyloc nut M8	
⑤	043608	1	Grab handle	
⑥	039680	1	Handle grip	
⑦	011067	4	Set screw M6 x 20	
⑧	011090	8	Plain washer M8	
⑨	011071	4	Nyloc nut M6	
⑩	045289	1	Floor plate	369

**i** Please note that the access ladder and grab handle is usually mounted on the driver side of the sweeper.



## Subframe to engine frame mounting

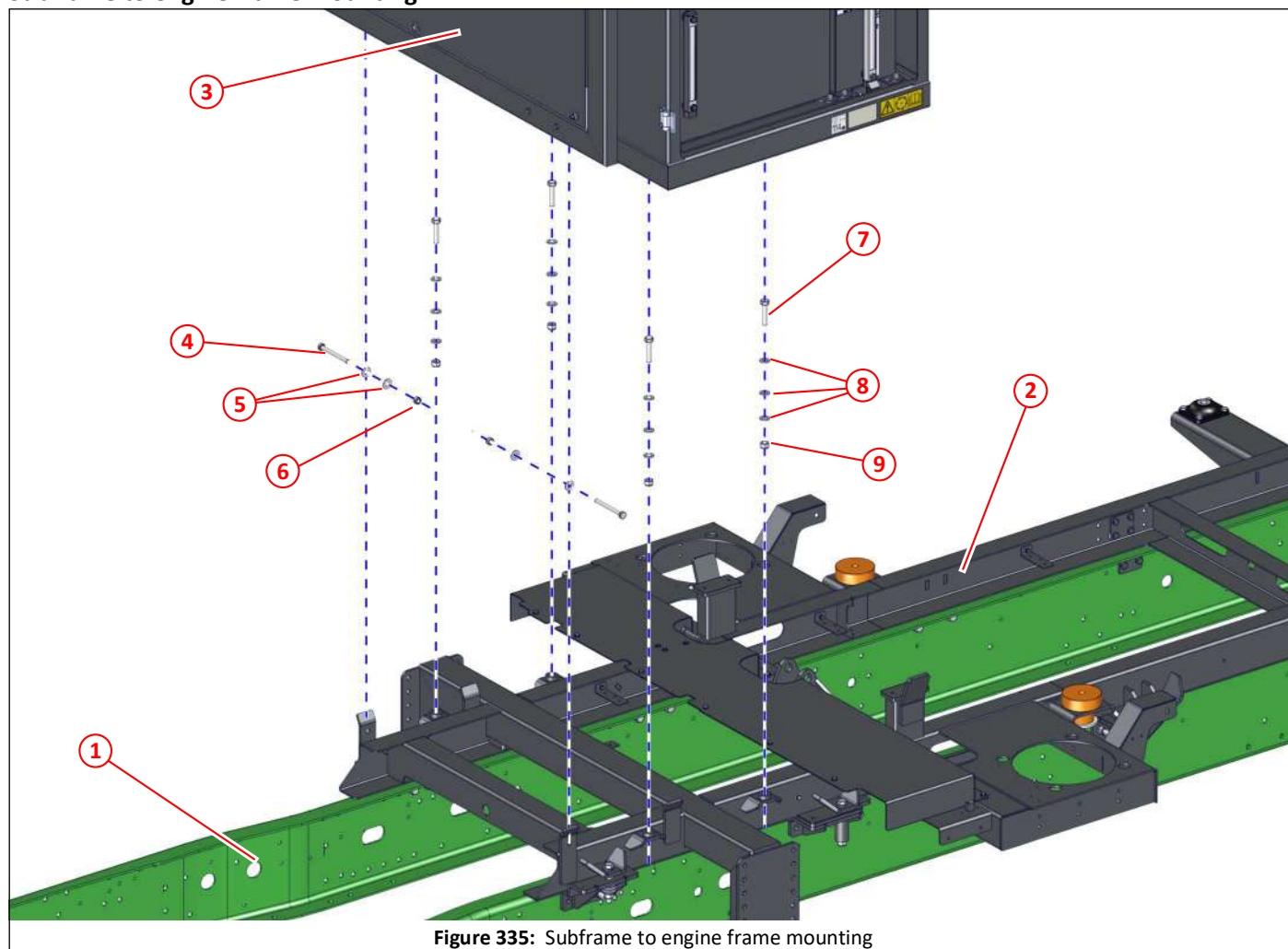

Figure 335: Subframe to engine frame mounting

Item	Part No	Qty	Description	
①			Chassis rails, shown for visualisation only	
②	042942	1	Subframe	365,366,367,372
③			Engine frame assembly	335
④	011064	2	Bolt M12 x 110	
⑤	011096	4	Plain washer M12	
⑥	011077	2	Nyloc nut M12	
⑦	000204	4	Set bolt M14 x 60	
⑧	000073	12	Plain washer M14	
⑨	000164	4	Nyloc nut M14	



Subframe to chassis mounting general arrangement

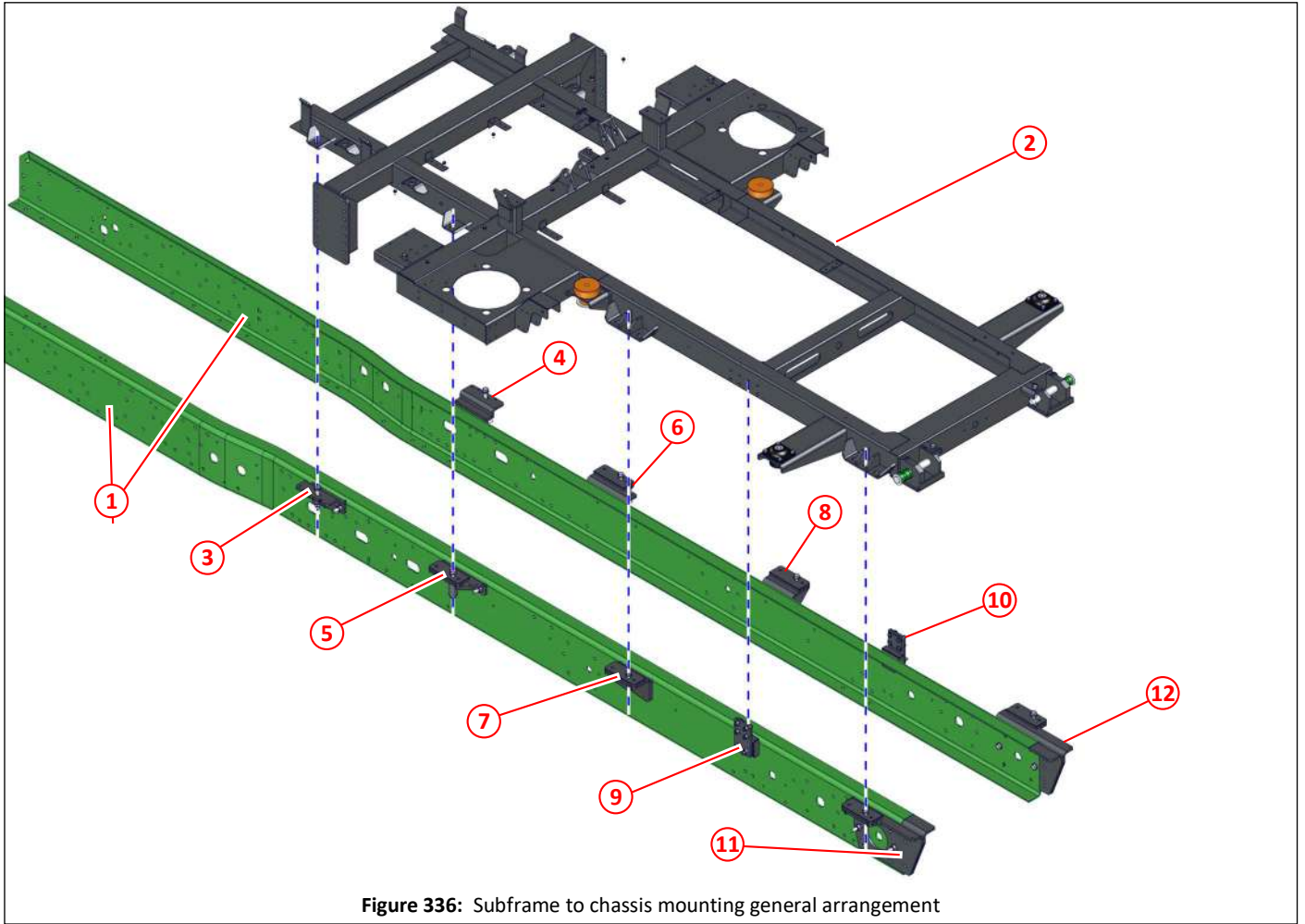

Figure 336: Subframe to chassis mounting general arrangement

Item	Part No	Qty	Description	
①			Chassis rails, shown for visualisation only	
②	042942	1	Subframe	365,366,367,372
③			Chassis mounting bracket, position 1, left hand side	
④			Chassis mounting bracket, position 1, right hand side	
⑤			Chassis mounting bracket, position 2, left hand side	
⑥			Chassis mounting bracket, position 2, right hand side	
⑦			Chassis mounting bracket, position 3, left hand side	
⑧			Chassis mounting bracket, position 3, right hand side	
⑨			Chassis lateral support, left hand side	
⑩			Chassis lateral support, right hand side	
⑪			Chassis mounting bracket, position 4, left hand side	
⑫			Chassis mounting bracket, position 4, right hand side	

NI			Subframe to chassis mountings, DAF	374
NI			Subframe to chassis mountings, SCANIA	381
NI			Subframe to chassis mountings, VOLVO	388
NI			Subframe to chassis mountings, IVECO	395
NI			Subframe to chassis mountings, MERCEDES	402
NI			Subframe to chassis mountings, MAN 18.290	409
NI			Subframe to chassis mountings, Freightliner M2 106	416

Always contact Scarab Parts Department when ordering mounting brackets with your sweepers Works No.

Subframe to chassis mountings, DAF

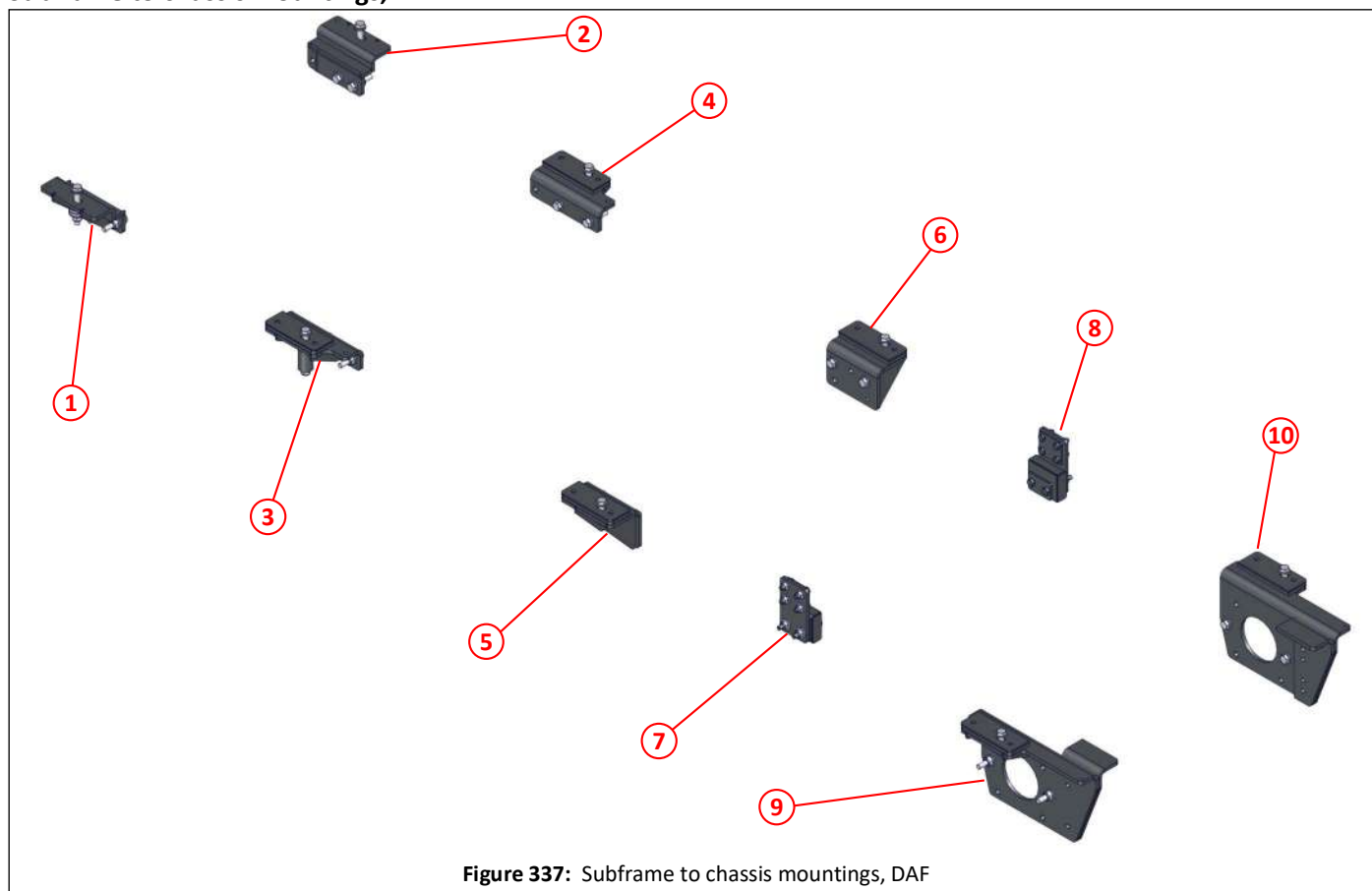

Figure 337: Subframe to chassis mountings, DAF

Item	Part No	Qty	Description	
①	043313	1	Chassis mounting bracket, position 1, left hand side, DAF LF55 E6	373,375
②	043314	1	Chassis mounting bracket, position 1, right hand side, DAF LF55 E6	373,375
③	043315	1	Chassis mounting bracket, position 2, left hand side, DAF LF55 E6	373,376
④	043316	1	Chassis mounting bracket, position 2, right hand side, DAF LF55 E6	373,376
⑤	043317	1	Chassis mounting bracket, position 3, left hand side, DAF LF55 E6	373,377
⑥	043318	1	Chassis mounting bracket, position 3, right hand side, DAF LF55 E6	373,377
⑦		1	Chassis lateral support, left hand side	373,386
⑧		1	Chassis lateral support, right hand side	373,387
⑨	043319	1	Chassis mounting bracket, position 4, left hand side, DAF LF55 E6	373,378
⑩	043120	1	Chassis mounting bracket, position 4, right hand side, DAF LF55 E6	373,378

**i** Please note that fixings shown are 'standard' and your actual sweeper may have different bolts, nuts and washers etc. than what is depicted. Quantities may also vary.  
The chassis mounting brackets shown are for specific manufacturer's chassis.

Please always contact Scarab Parts Department when needing to order mounting brackets and fixings with your sweepers Works No. to ensure we match what was originally supplied.

## Subframe to chassis mountings, position 1, DAF

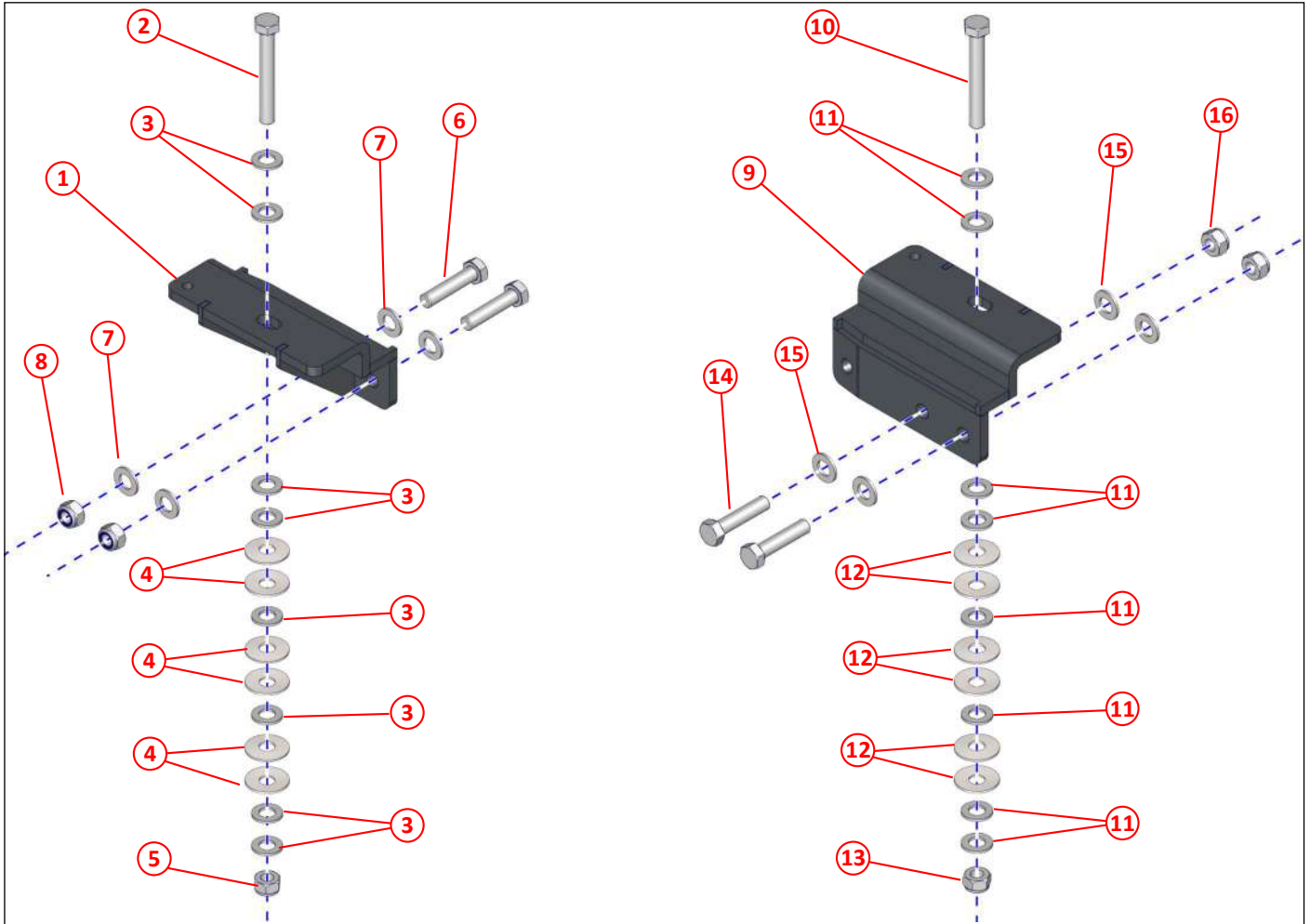

Figure 338: Subframe to chassis mountings, position 1, DAF

Item	Part No	Qty	Description	
①	043313	1	Bracket, chassis mounting, position 1, left hand side, DAF LF55 E6	373,374
②	000102	1	Bolt M14 x 100	
③	000073	8	Plain washer M14	
④	036824	6	Spring, disc	
⑤	000164	1	Nyloc nut M14	
⑥	000204	2	Set bolt M14 x 60	
⑦	000073	4	Plain washer M14	
⑧	000164	2	Nyloc nut M14	
⑨	043314	1	Bracket, chassis mounting, position 1, right hand side, DAF LF55 E6	373,374
⑩	000102	1	Bolt M14 x 100	
⑪	000073	8	Plain washer M14	
⑫	036824	6	Spring, disc	
⑬	000164	1	Nyloc nut M14	
⑭	000204	2	Set bolt M14 x 60	
⑮	000073	4	Plain washer M14	
⑯	000164	2	Nyloc nut M14	

Subframe to chassis mountings, position 2, DAF

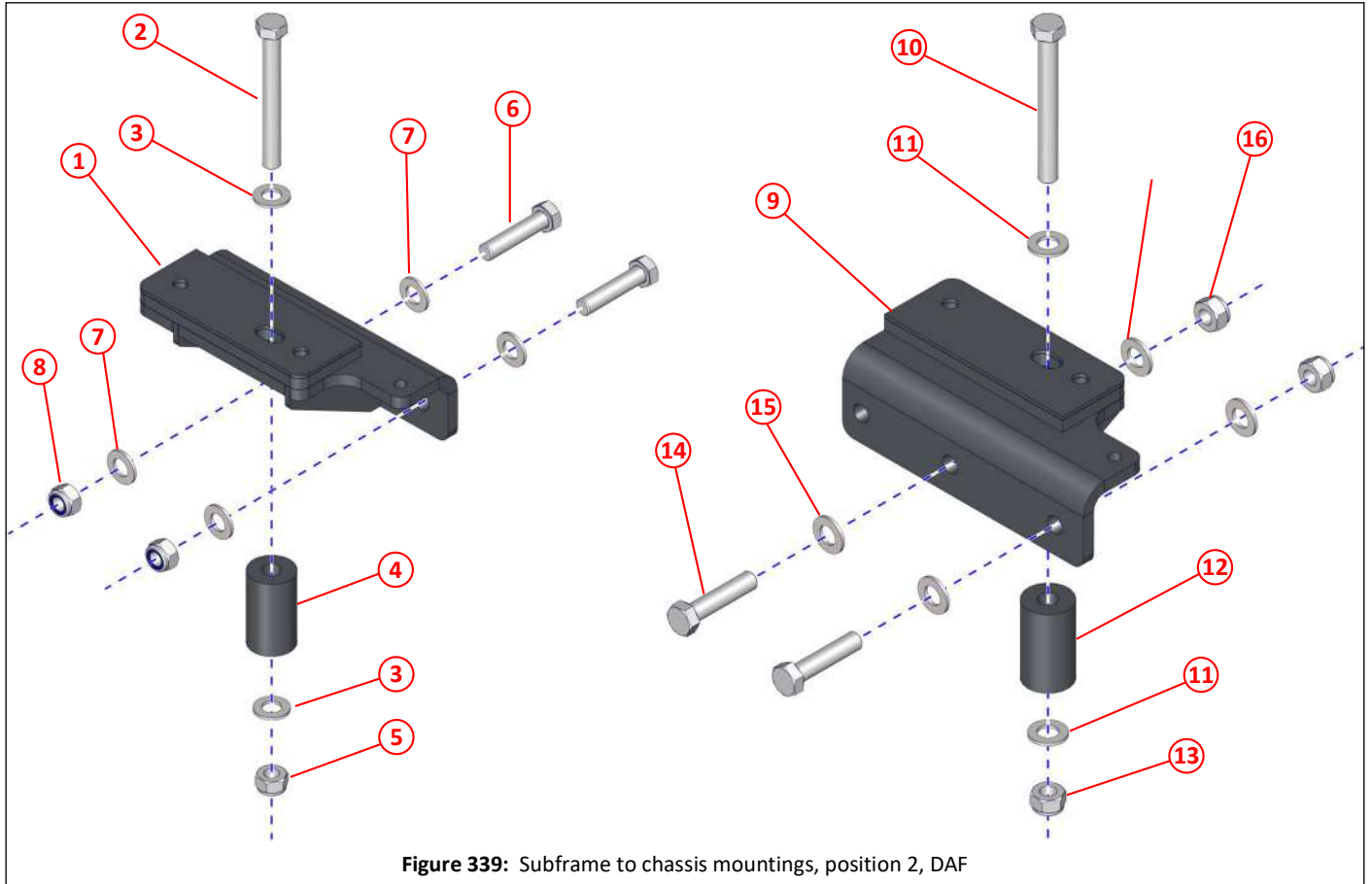

Figure 339: Subframe to chassis mountings, position 2, DAF

Item	Part No	Qty	Description	
①	043315	1	Bracket, chassis mounting, position 2, left hand side, DAF LF55 E6	373,374
②	000163	1	Bolt M14 x 120	
③	000073	2	Plain washer M14	
④	034909	1	Spacer $\phi 15 \times \phi 38 \times 65$	
⑤	000164	1	Nyloc nut M14	
⑥	000204	2	Set bolt M14 x 60	
⑦	000073	4	Plain washer M14	
⑧	000164	2	Nyloc nut M14	
⑨	043316	1	Bracket, chassis mounting, position 2, right hand side, DAF LF55 E6	373,374
⑩	000163	1	Bolt M14 x 120	
⑪	000073	2	Plain washer M14	
⑫	034909	1	Spacer $\phi 15 \times \phi 38 \times 65$	
⑬	000164	1	Nyloc nut M14	
⑭	000204	2	Set bolt M14 x 60	
⑮	000073	4	Plain washer M14	
⑯	000164	2	Nyloc nut M14	

## Subframe to chassis mountings, position 3, DAF

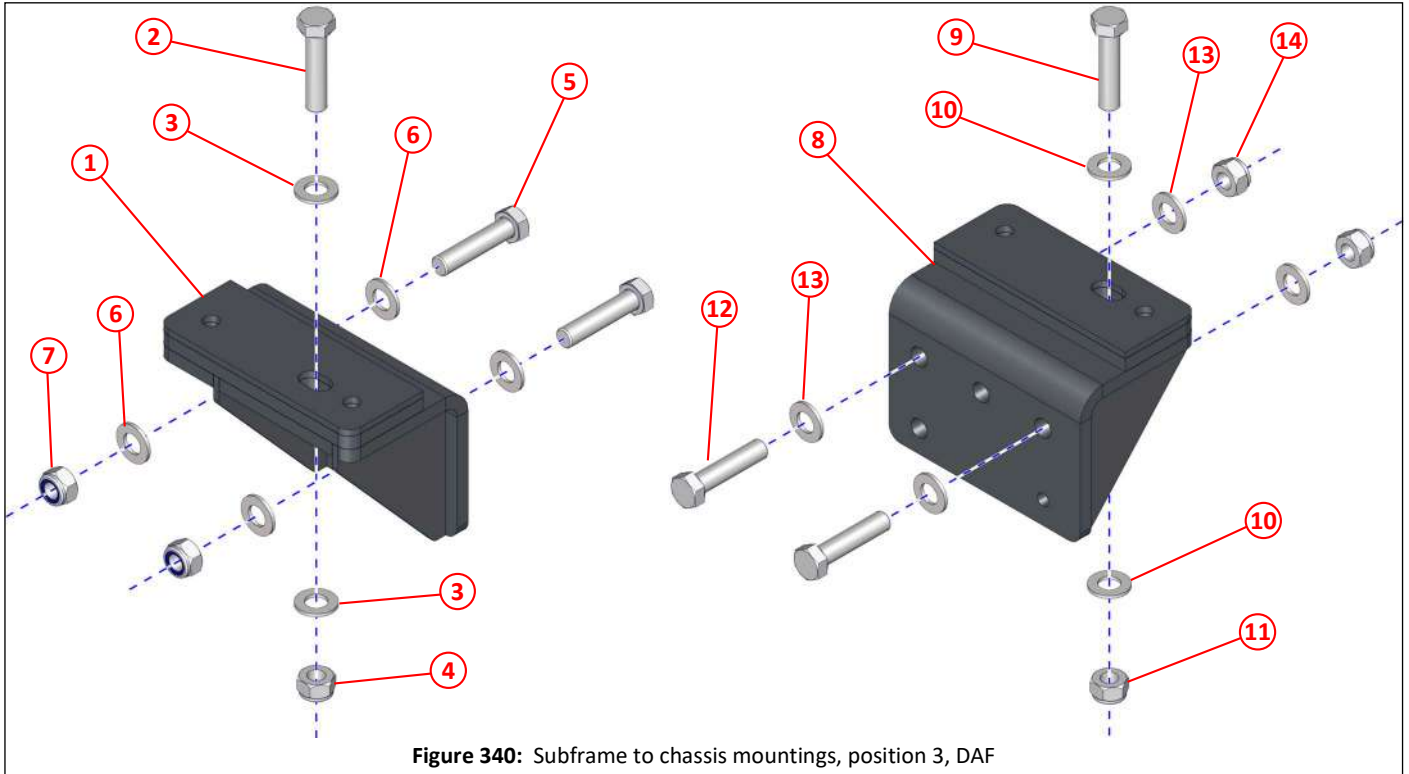

Figure 340: Subframe to chassis mountings, position 3, DAF

Item	Part No	Qty	Description	
①	043317	1	Bracket, chassis mounting, position 3, left hand side, DAF LF55 E6	373,374
②	000204	1	Bolt M14 x 60	
③	000073	2	Plain washer M14	
④	000164	1	Nyloc nut M14	
⑤	000204	2	Bolt M14 x 60	
⑥	000073	4	Plain washer M14	
⑦	000164	2	Nyloc nut M14	
⑧	043318	1	Bracket, chassis mounting, position 3, right hand side, DAF LF55 E6	373,374
⑨	000204	1	Bolt M14 x 60	
⑩	000073	2	Plain washer M14	
⑪	000164	1	Nyloc nut M14	
⑫	000204	2	Bolt M14 x 60	
⑬	000073	4	Plain washer M14	
⑭	000164	2	Nyloc nut M14	

Subframe to chassis mountings, position 4, DAF

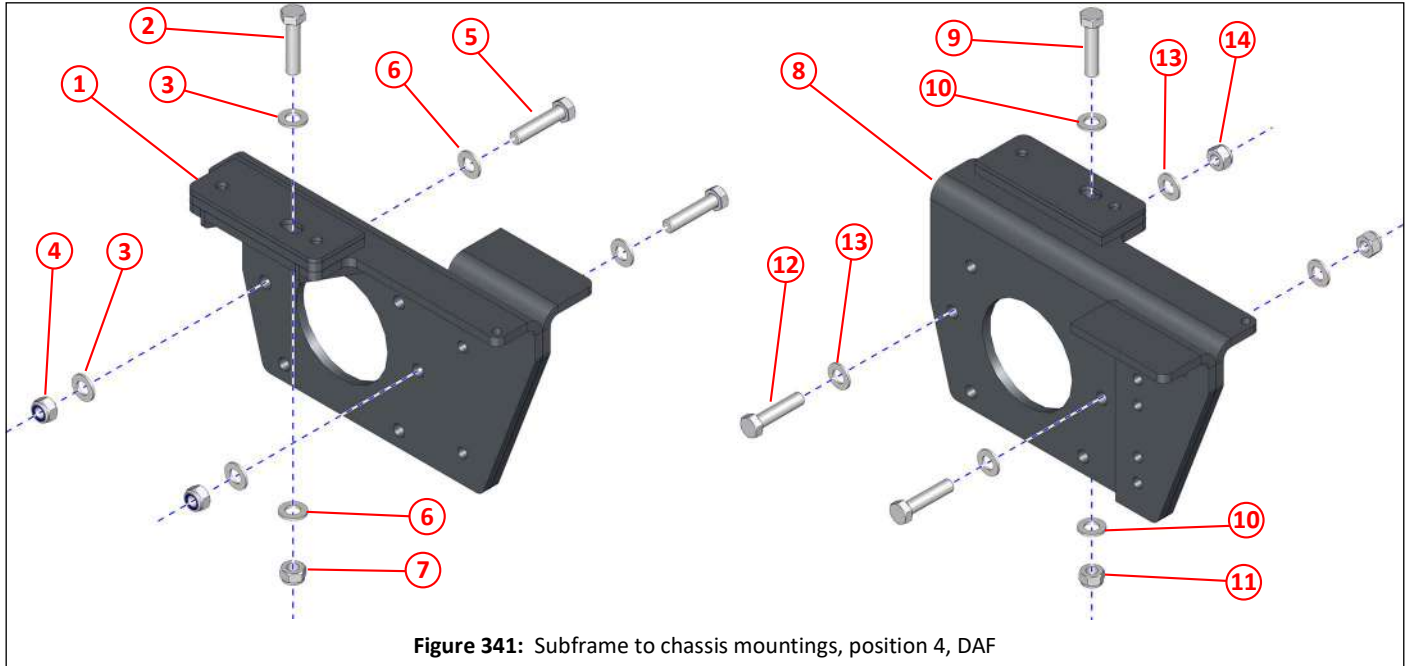

Figure 341: Subframe to chassis mountings, position 4, DAF

Item	Part No	Qty	Description	
①	043319	1	Bracket, chassis mounting, position 4, left hand side, DAF LF55 E6	373,374
②	000204	1	Bolt M14 x 60	
③	000073	2	Plain washer M14	
④	000164	1	Nyloc nut M14	
⑤	000204	2	Bolt M14 x 60	
⑥	000073	4	Plain washer M14	
⑦	000164	2	Nyloc nut M14	
⑧	043320	1	Bracket, chassis mounting, position 4, right hand side, DAF LF55 E6	373,374
⑨	000204	1	Bolt M14 x 60	
⑩	000073	2	Plain washer M14	
⑪	000164	1	Nyloc nut M14	
⑫	000204	2	Bolt M14 x 60	
⑬	000073	4	Plain washer M14	
⑭	000164	2	Nyloc nut M14	



Subframe to chassis mountings lateral support, left side, DAF

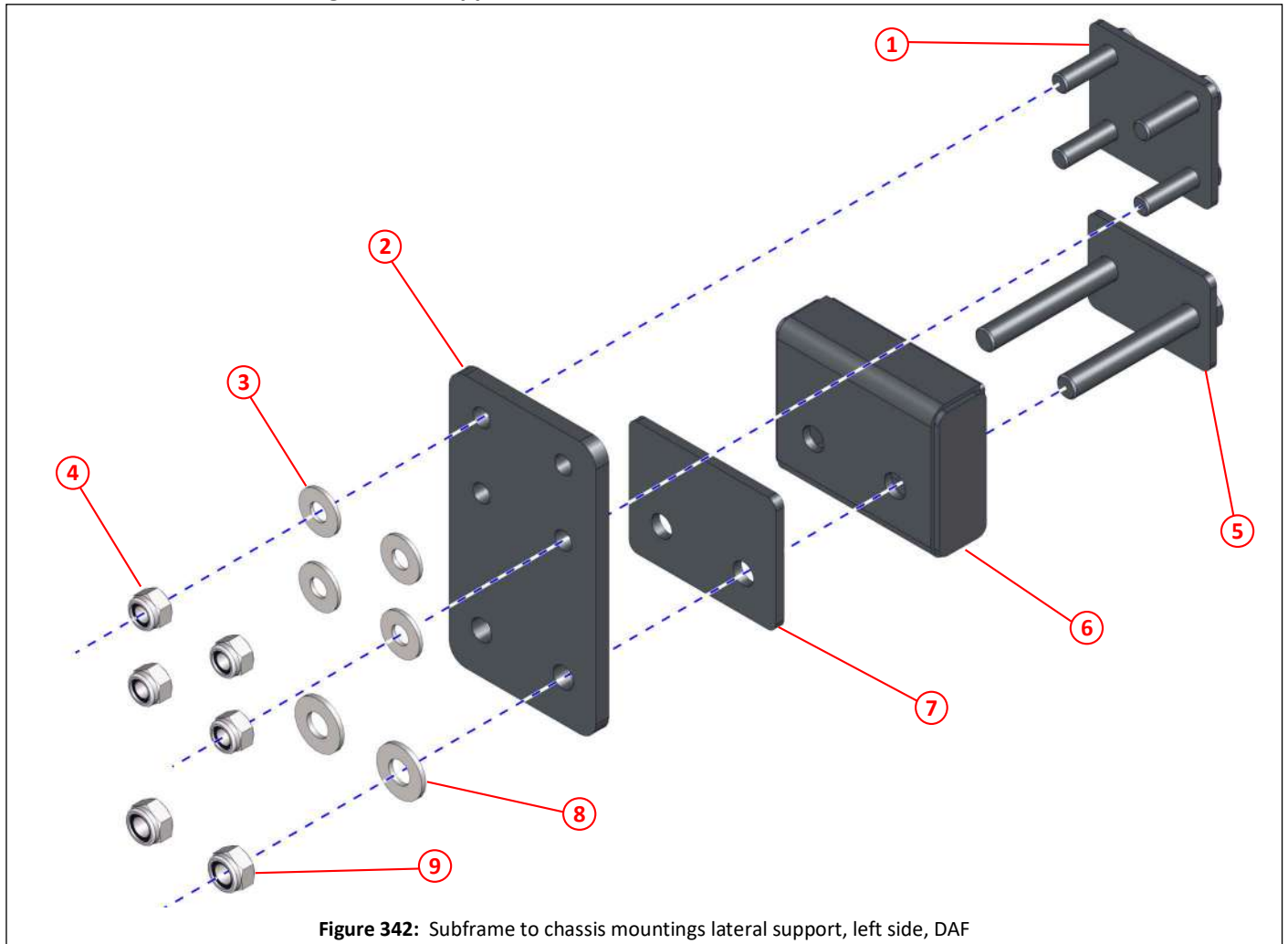

Figure 342: Subframe to chassis mountings lateral support, left side, DAF

Item	Part No	Qty	Description	
①	044393	1	Upper plate, lateral support	373,374
②	040356	1	Rear plate, lateral support	373,374
③	011094	4	Plain washer M10	
④	011075	4	Nyloc nut M10	
⑤	044395	1	Lower plate, lateral support	373,374
⑥	038140	1	Packer, lateral support	373,374
⑦	034387	1	Packer, type B	
⑧	011096	2	Plain washer M12	
⑨	011077	2	Nyloc nut M12	

Subframe to chassis mountings lateral support, right side, DAF

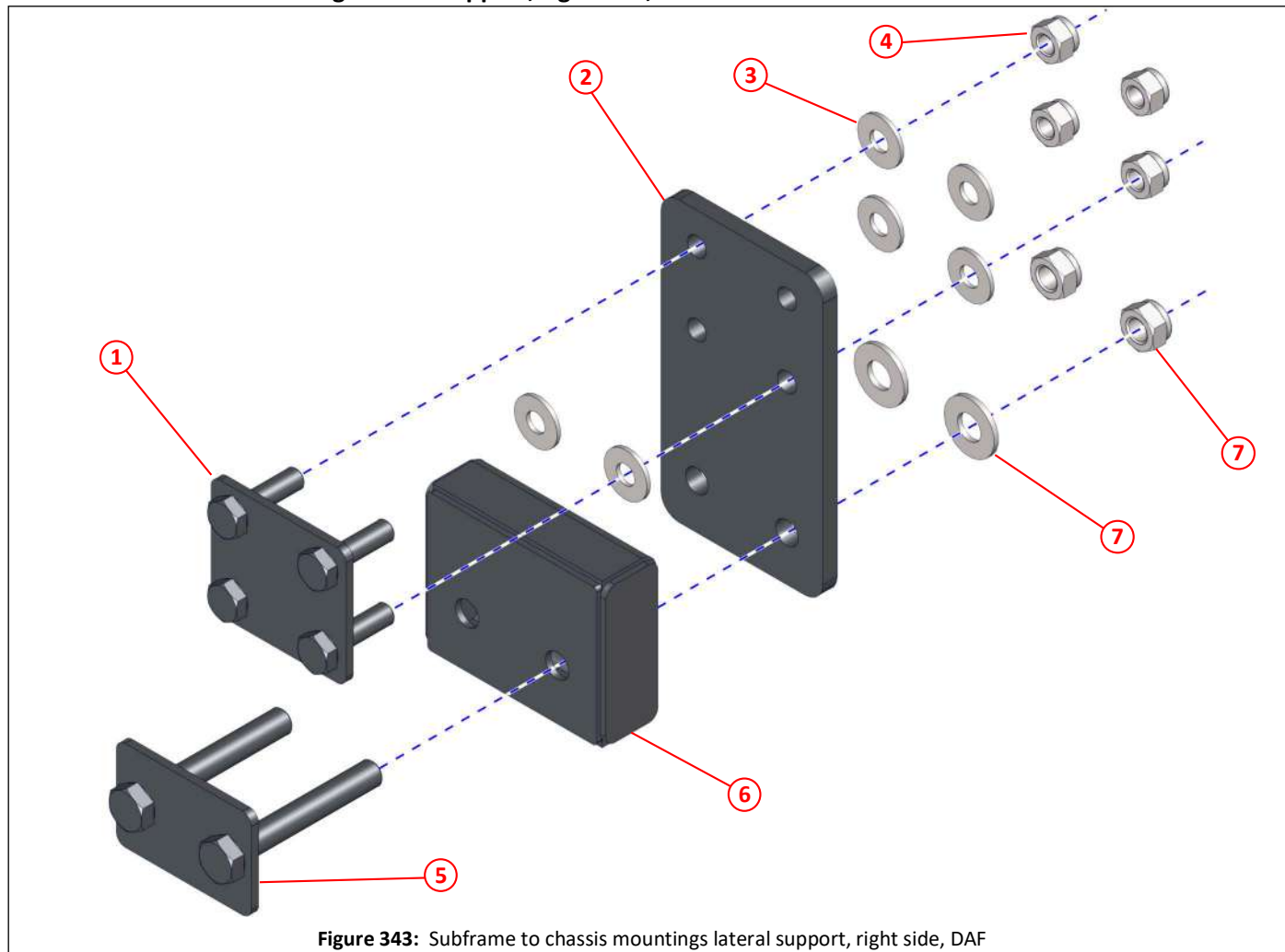

Figure 343: Subframe to chassis mountings lateral support, right side, DAF

Item	Part No	Qty	Description	
①	044393	1	Upper plate, lateral support	373,374
②	040356	1	Rear plate, lateral support	373,374
③	011094	4	Plain washer M10	
④	011075	4	Nyloc nut M10	
⑤	044395	1	Lower plate, lateral support	373,
⑥	038140	1	Packer, lateral support	
⑦	011096	2	Plain washer M12	
⑧	011077	2	Nyloc nut M12	

Subframe to chassis mountings, SCANIA

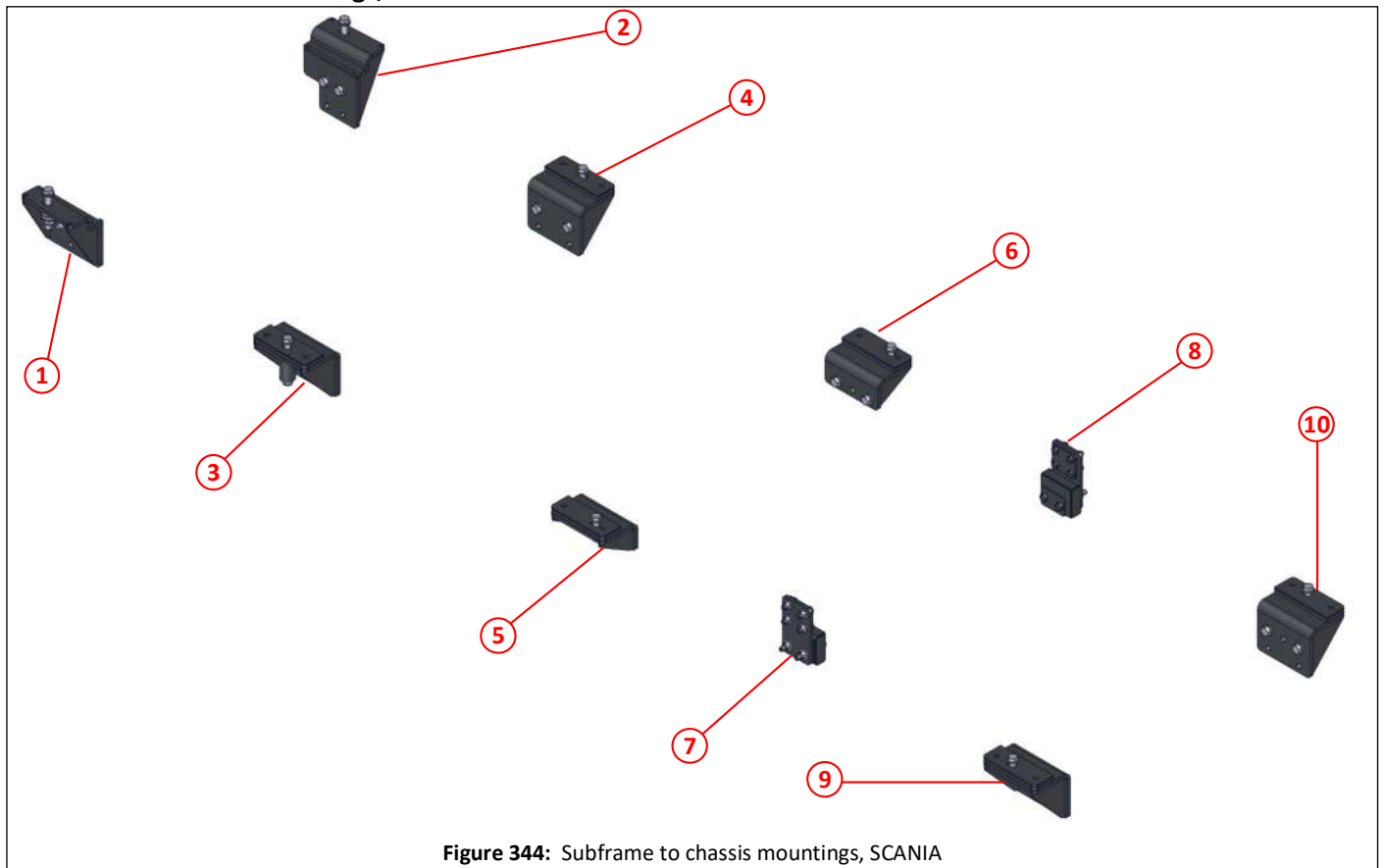

Figure 344: Subframe to chassis mountings, SCANIA

Item	Part No	Qty	Description	
①	044438	1	Chassis mounting bracket, position 1, left hand side, SCANIA	373,382
②	044439	1	Chassis mounting bracket, position 1, right hand side, SCANIA	373,382
③	043315	1	Chassis mounting bracket, position 2, left hand side, SCANIA	373,376
④	043316	1	Chassis mounting bracket, position 2, right hand side, SCANIA	373,376
⑤	043317	1	Chassis mounting bracket, position 3, left hand side, SCANIA	373,377
⑥	043318	1	Chassis mounting bracket, position 3, right hand side, SCANIA	373,377
⑦		1	Chassis lateral support, left hand side	373,378
⑧		1	Chassis lateral support, right hand side	373,378
⑨	043319	1	Chassis mounting bracket, position 4, left hand side, SCANIA	373,386
⑩	043120	1	Chassis mounting bracket, position 4, right hand side, SCANIA	373,387

**i** Please note that fixings shown are 'standard' and your actual sweeper may have different bolts, nuts and washers etc. than what is depicted. Quantities may also vary.  
The chassis mounting brackets shown are for specific manufacturer's chassis.

Please always contact Scarab Parts Department when needing to order mounting brackets and fixings with your sweepers Works No. to ensure we match what was originally supplied.

Subframe to chassis mountings, position 1, SCANIA

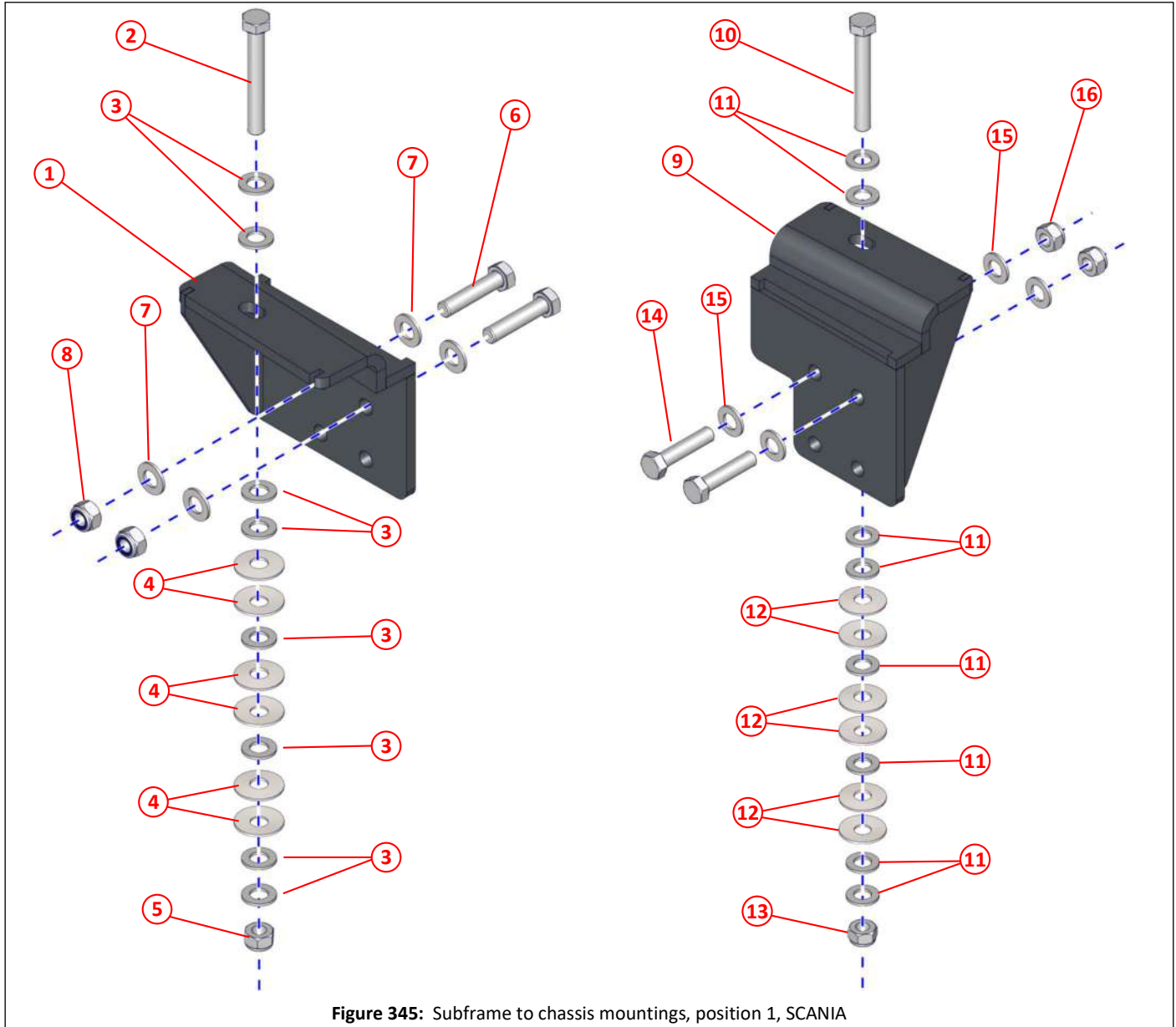

Figure 345: Subframe to chassis mountings, position 1, SCANIA

Item	Part No	Qty	Description	
①	044438	1	Bracket, chassis mounting, position 1, left hand side, SCANIA P250 E6 3900	381
②	000102	1	Bolt M14 x 100	
③	000073	8	Plain washer M14	
④	036824	6	Spring, disc	
⑤	000164	1	Nyloc nut M14	
⑥	000204	2	Set bolt M14 x 60	
⑦	000073	4	Plain washer M14	
⑧	000164	2	Nyloc nut M14	
⑨	044439	1	Bracket, chassis mounting, position 1, left hand side, SCANIA P250 E6 3900	381
⑩	000102	1	Bolt M14 x 100	
⑪	000073	8	Plain washer M14	
⑫	036824	6	Spring, disc	
⑬	000164	1	Nyloc nut M14	
⑭	000204	2	Set bolt M14 x 60	
⑮	000073	4	Plain washer M14	
⑯	000164	2	Nyloc nut M14	

## Subframe to chassis mountings, position 2, SCANIA

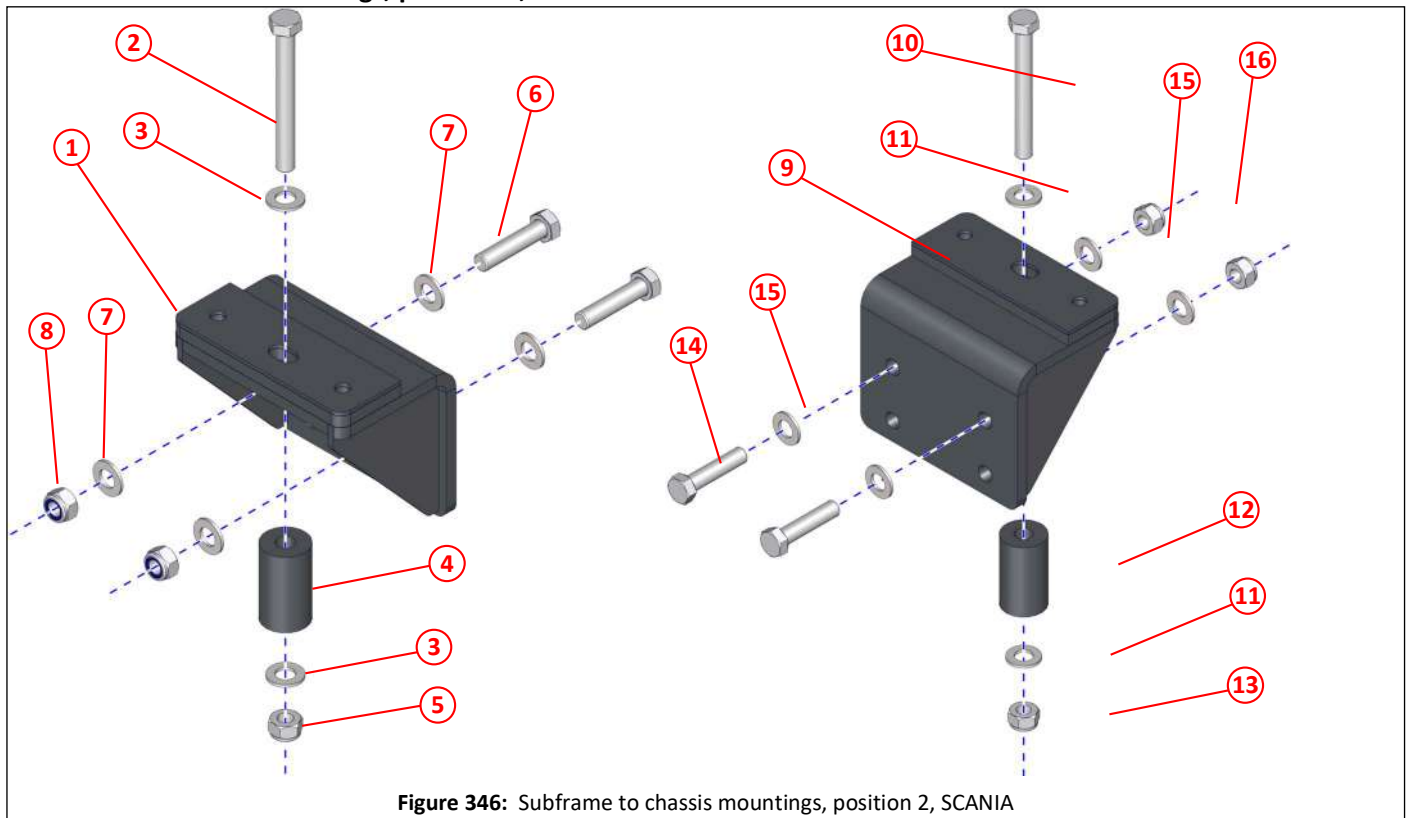

Figure 346: Subframe to chassis mountings, position 2, SCANIA

Item	Part No	Qty	Description	
①	044440	1	Bracket, chassis mounting, position 2, left hand side, SCANIA P250 E6 3900	381
②	000163	1	Bolt M14 x 120	
③	000073	2	Plain washer M14	
④	034909	1	Spacer $\varnothing 15 \times \varnothing 38 \times 65$	
⑤	000164	1	Nyloc nut M14	
⑥	000204	2	Set bolt M14 x 60	
⑦	000073	4	Plain washer M14	
⑧	000164	2	Nyloc nut M14	
⑨	044441	1	Bracket, chassis mounting, position 2, right hand side, SCANIA P250 E6 3900	381
⑩	000163	1	Bolt M14 x 120	
⑪	000073	2	Plain washer M14	
⑫	034909	1	Spacer $\varnothing 15 \times \varnothing 38 \times 65$	
⑬	000164	1	Nyloc nut M14	
⑭	000204	2	Set bolt M14 x 60	
⑮	000073	4	Plain washer M14	
⑯	000164	2	Nyloc nut M14	

Subframe to chassis mountings, position 3, SCANIA

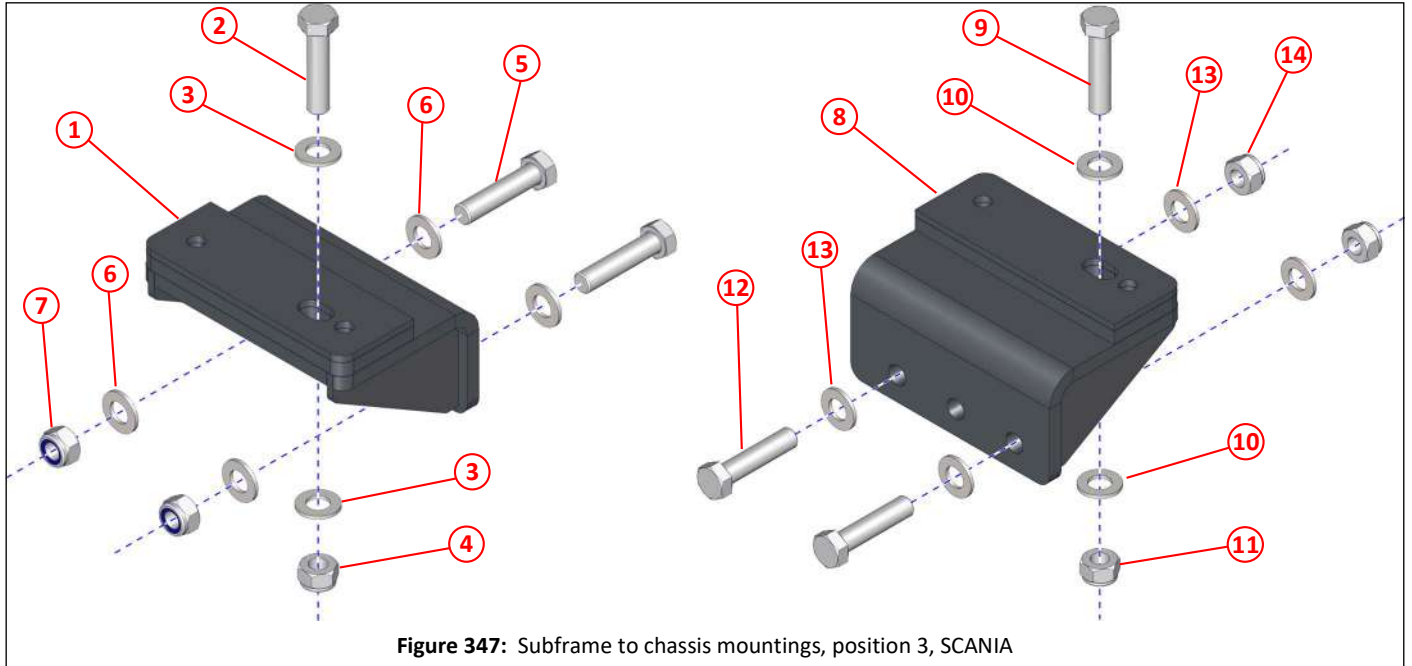

Figure 347: Subframe to chassis mountings, position 3, SCANIA

Item	Part No	Qty	Description	
①	044442	1	Bracket, chassis mounting, position 3, left hand side, SCANIA P250 E6 3900	381
②	000204	1	Bolt M14 x 60	
③	000073	2	Plain washer M14	
④	000164	1	Nyloc nut M14	
⑤	000204	2	Bolt M14 x 60	
⑥	000073	4	Plain washer M14	
⑦	000164	2	Nyloc nut M14	
⑧	044443	1	Bracket, chassis mounting, position 3, right hand side, SCANIA P250 E6 3900	381
⑨	000204	1	Bolt M14 x 60	
⑩	000073	2	Plain washer M14	
⑪	000164	1	Nyloc nut M14	
⑫	000204	2	Bolt M14 x 60	
⑬	000073	4	Plain washer M14	
⑭	000164	2	Nyloc nut M14	



Subframe to chassis mountings, position 4, SCANIA

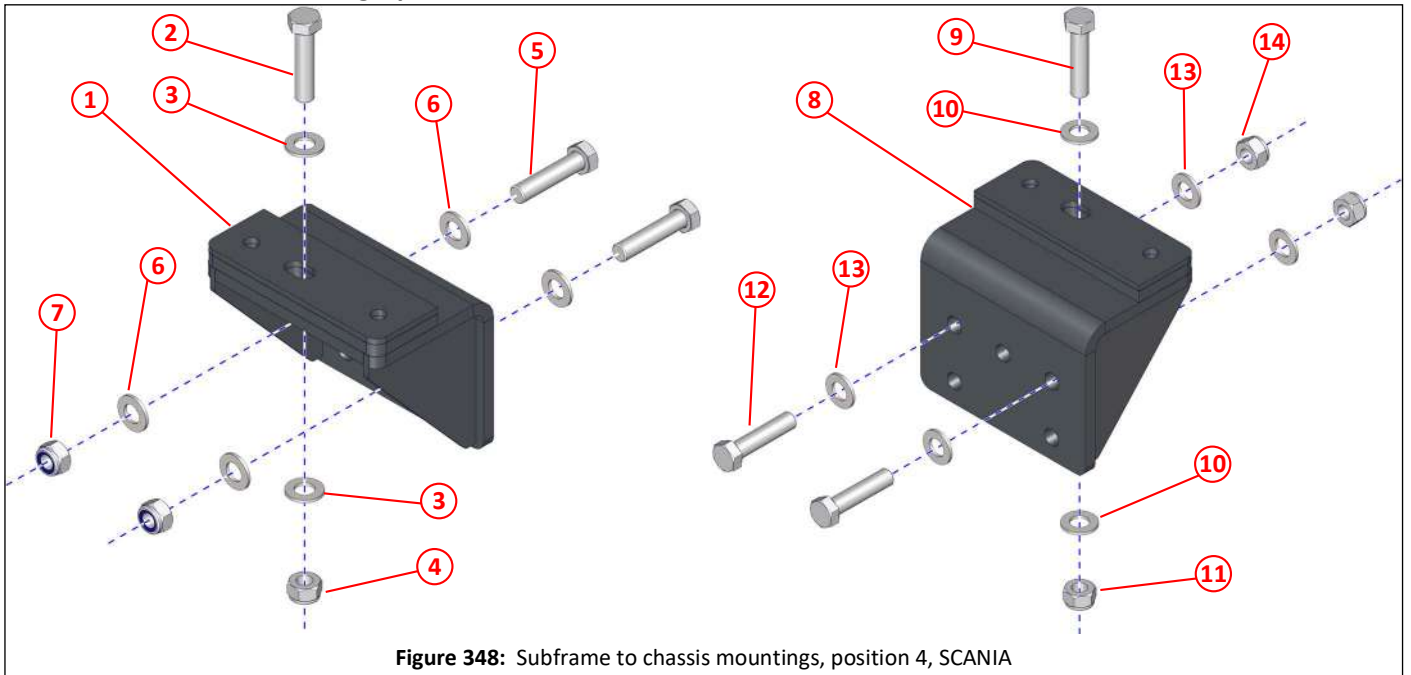

Figure 348: Subframe to chassis mountings, position 4, SCANIA

Item	Part No	Qty	Description	
①	044444	1	Bracket, chassis mounting, position 4, left hand side, SCANIA P250 E6 3900	381
②	000204	1	Bolt M14 x 60	
③	000073	2	Plain washer M14	
④	000164	1	Nyloc nut M14	
⑤	000204	2	Bolt M14 x 60	
⑥	000073	4	Plain washer M14	
⑦	000164	2	Nyloc nut M14	
⑧	044445	1	Bracket, chassis mounting, position 4, right hand side, SCANIA P250 E6 3900	381
⑨	000204	1	Bolt M14 x 60	
⑩	000073	2	Plain washer M14	
⑪	000164	1	Nyloc nut M14	
⑫	000204	2	Bolt M14 x 60	
⑬	000073	4	Plain washer M14	
⑭	000164	2	Nyloc nut M14	

Subframe to chassis mountings lateral support, left side, SCANIA

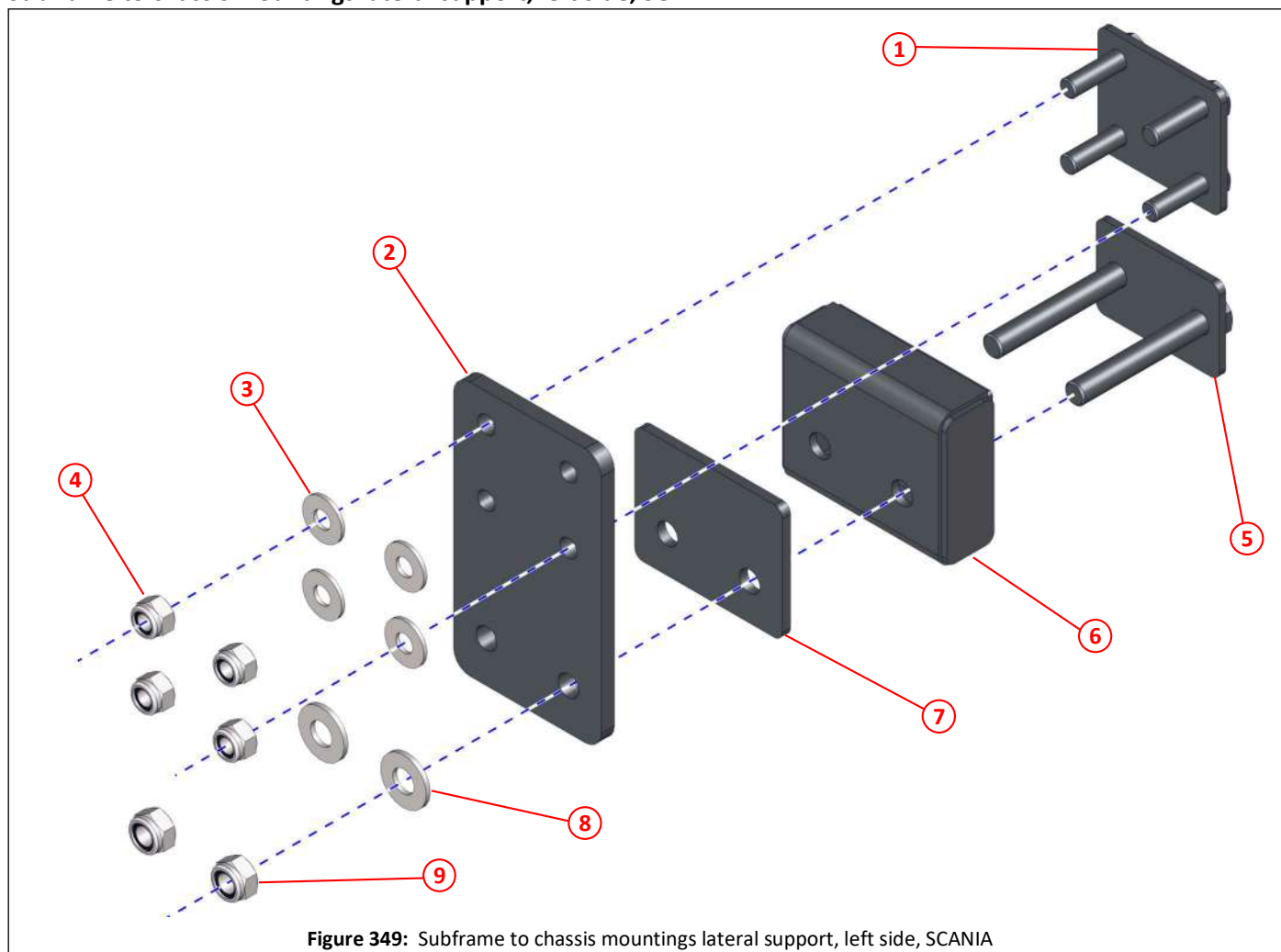

Figure 349: Subframe to chassis mountings lateral support, left side, SCANIA

Item	Part No	Qty	Description
①	044393	1	Upper plate, lateral support
②	040356	1	Rear plate, lateral support
③	011094	4	Plain washer M10
④	011075	4	Nyloc nut M10
⑤	044395	1	Lower plate, lateral support
⑥	038140	1	Packer, lateral support
⑦	034387	1	Packer, type B
⑧	011096	2	Plain washer M12
⑨	011077	2	Nyloc nut M12

Subframe to chassis mountings lateral support, right side, SCANIA

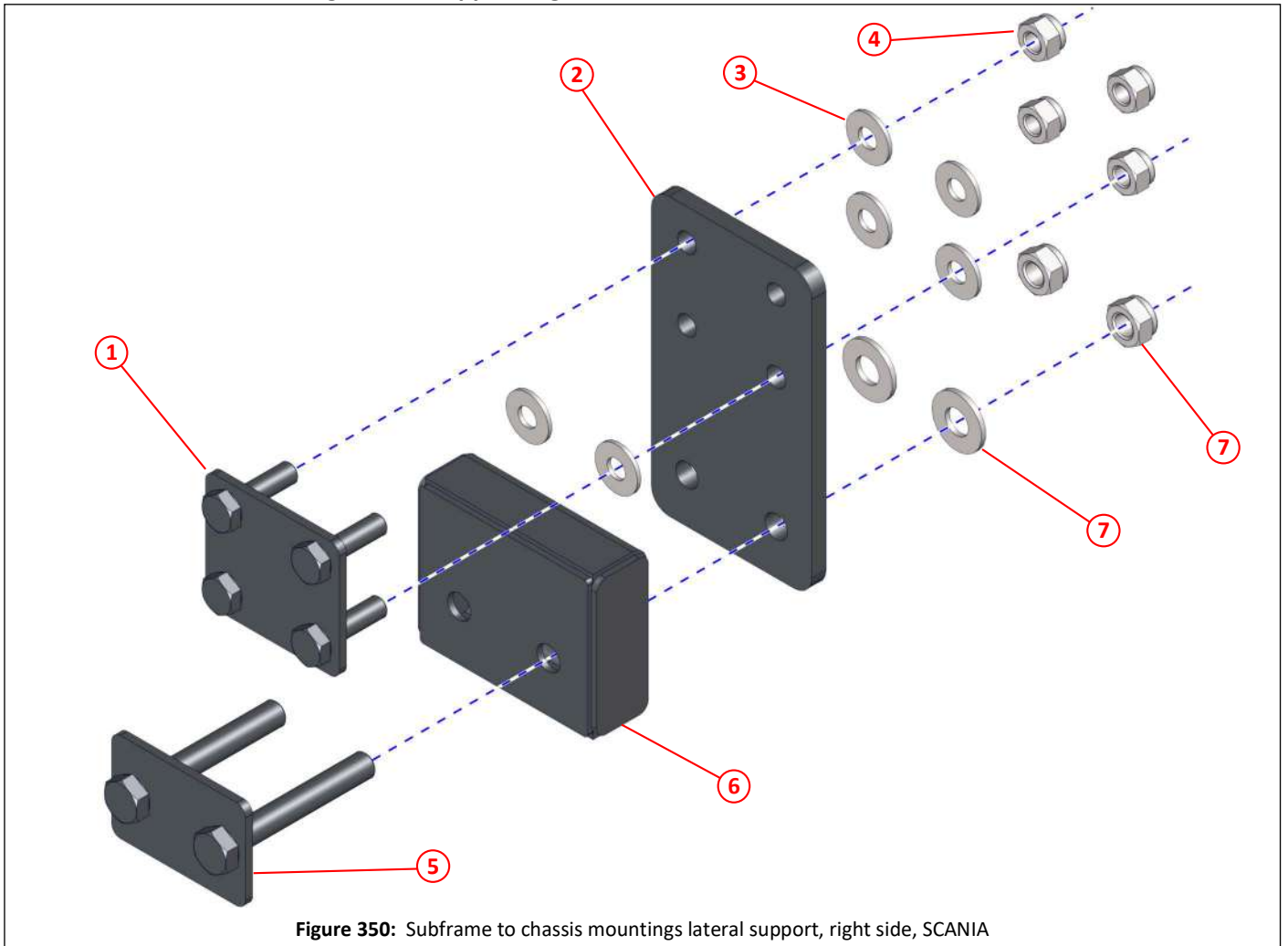

Figure 350: Subframe to chassis mountings lateral support, right side, SCANIA

Item	Part No	Qty	Description	
①	044393	1	Upper plate, lateral support	
②	040356	1	Rear plate, lateral support	
③	011094	4	Plain washer M10	
④	011075	4	Nyloc nut M10	
⑤	044395	1	Lower plate, lateral support	
⑥	038140	1	Packer, lateral support	
⑦	011096	2	Plain washer M12	
⑧	011077	2	Nyloc nut M12	

## Subframe to chassis mountings, VOLVO

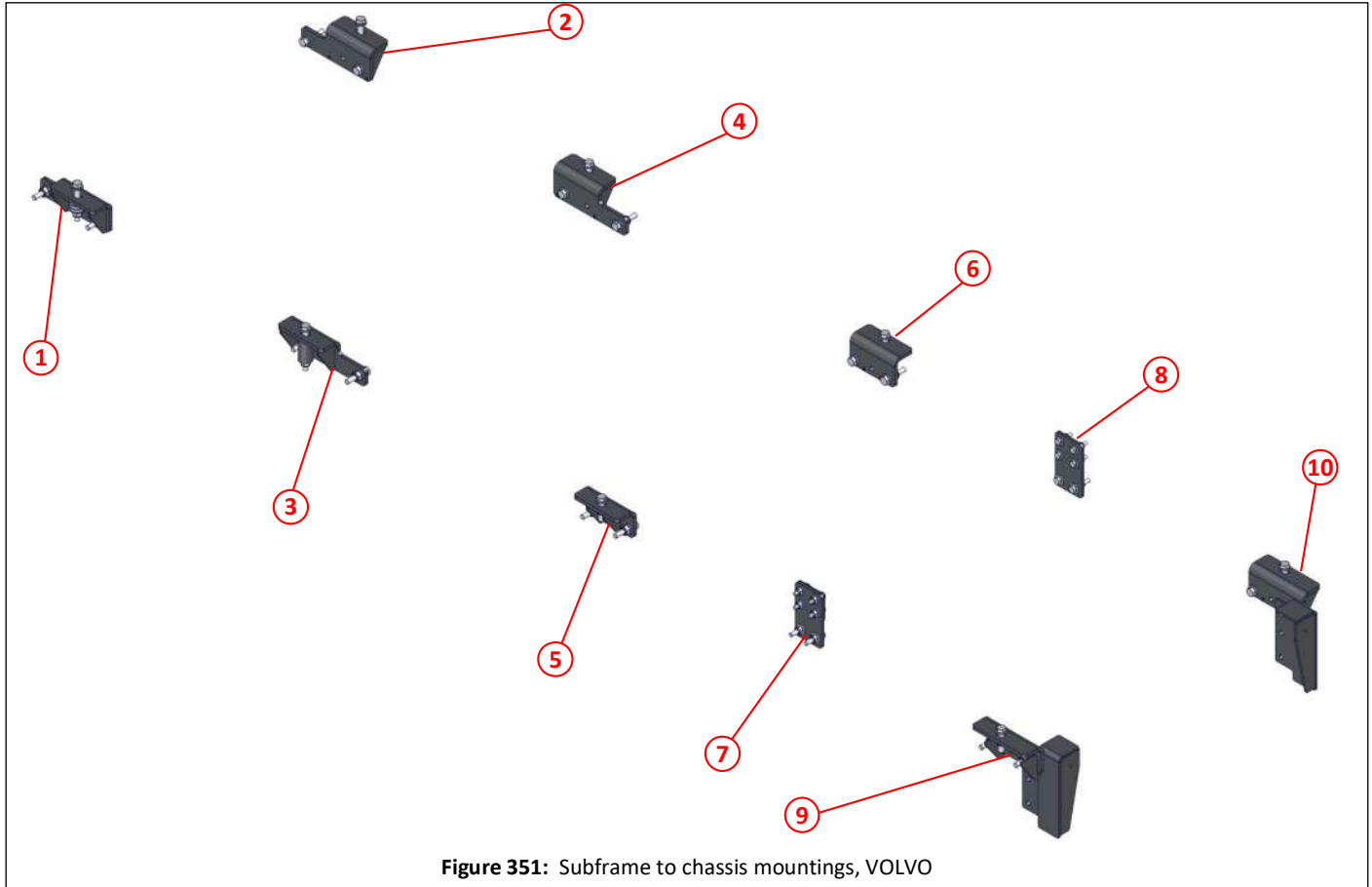

Figure 351: Subframe to chassis mountings, VOLVO

Item	Part No	Qty	Description	
①	043999	1	Chassis mounting bracket, position 1, left hand side, VOLVO	389
②	044000	1	Chassis mounting bracket, position 1, right hand side, VOLVO	389
③	043994	1	Chassis mounting bracket, position 2, left hand side, VOLVO	390
④	043995	1	Chassis mounting bracket, position 2, right hand side, VOLVO	390
⑤	043993	1	Chassis mounting bracket, position 3, left hand side, VOLVO	391
⑥	043993	1	Chassis mounting bracket, position 3, right hand side, VOLVO	391
⑦		1	Chassis lateral support, left hand side	393
⑧		1	Chassis lateral support, right hand side	394
⑨	043319	1	Chassis mounting bracket, position 4, left hand side, VOLVO	392
⑩	043120	1	Chassis mounting bracket, position 4, right hand side, VOLVO	392

**i** Please note that fixings shown are 'standard' and your actual sweeper may have different bolts, nuts and washers etc. than what is depicted. Quantities may also vary.  
The chassis mounting brackets shown are for specific manufacturer's chassis.

Please always contact Scarab Parts Department when needing to order mounting brackets and fixings with your sweepers Works No. to ensure we match what was originally supplied.

## Subframe to chassis mountings, position 1, VOLVO

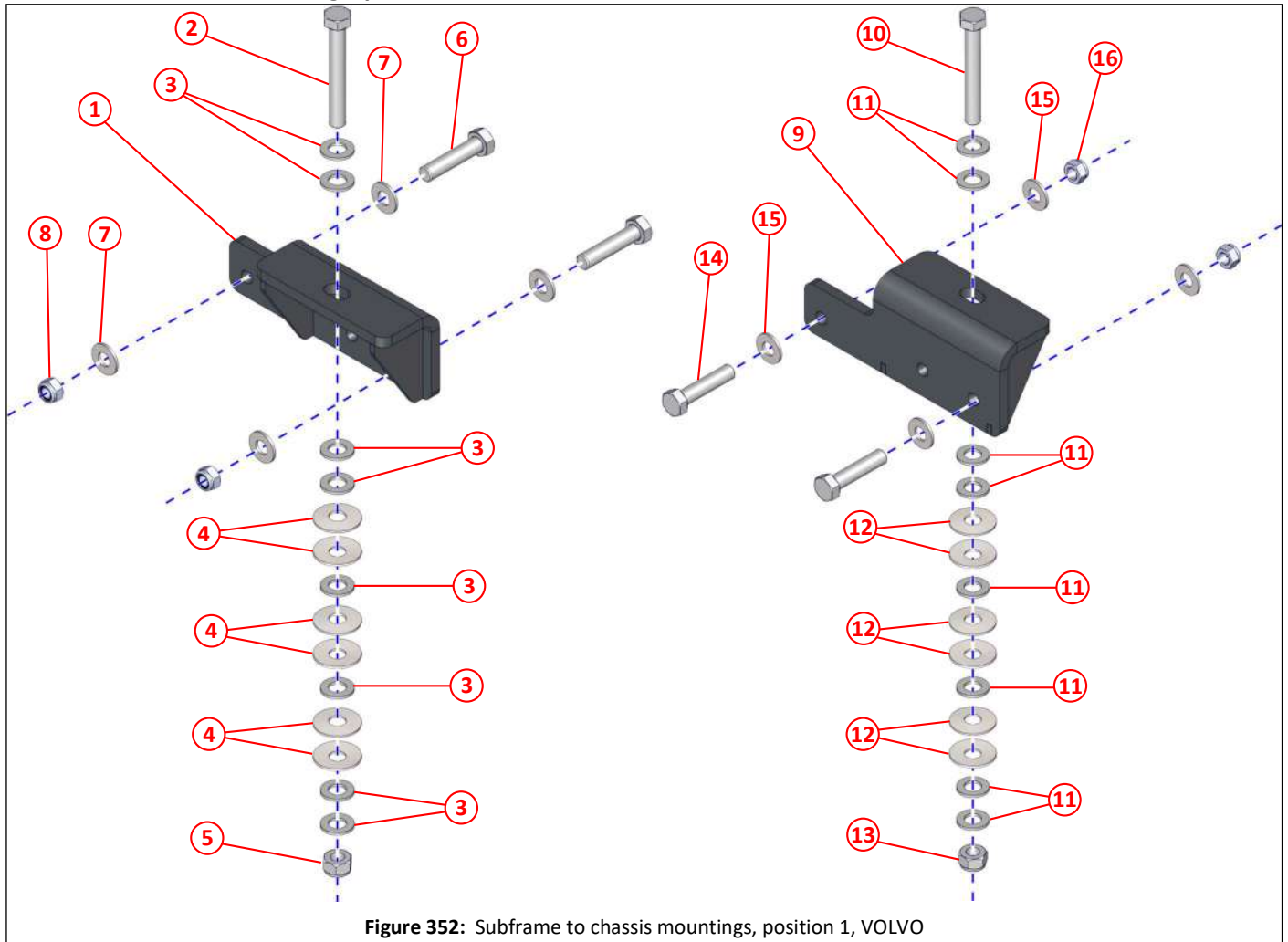

Figure 352: Subframe to chassis mountings, position 1, VOLVO

Item	Part No	Qty	Description	
①	043999	1	Bracket, chassis mounting, position 1, left hand side, VOLVO	388
②	000102	1	Bolt M14 x 100	
③	000073	8	Plain washer M14	
④	036824	6	Spring, disc	
⑤	000164	1	Nyloc nut M14	
⑥	000204	2	Set bolt M12 x 60 x 1.25	
⑦	011096	4	Plain washer M12	
⑧	011086	2	Nyloc nut M12 x 1.25	
⑨	044000	1	Bracket, chassis mounting, position 1, left hand side, VOLVO	388
⑩	000102	1	Bolt M14 x 100	
⑪	000073	8	Plain washer M14	
⑫	036824	6	Spring, disc	
⑬	000164	1	Nyloc nut M14	
⑭	000391	2	Set bolt M12 x 60 x 1.25	
⑮	011096	4	Plain washer M12	
⑯	011086	2	Nyloc nut M12 x 1.25	

## Subframe to chassis mountings, position 2, VOLVO

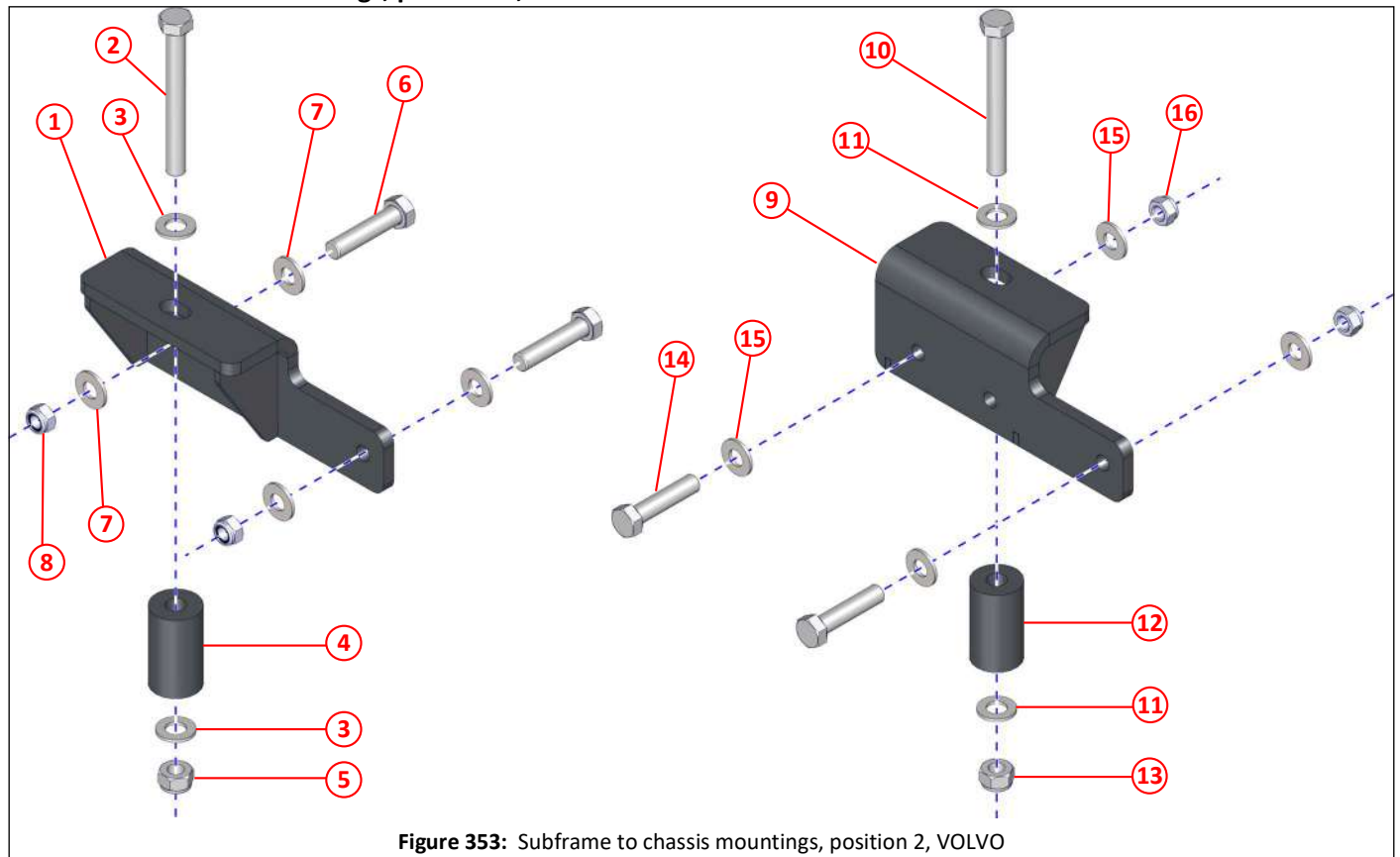

Figure 353: Subframe to chassis mountings, position 2, VOLVO

Item	Part No	Qty	Description	
①	043994	1	Bracket, chassis mounting, position 2, left hand side, VOLVO	388
②	000163	1	Bolt M14 x 120	
③	000073	2	Plain washer M14	
④	034909	1	Spacer $\varnothing 15 \times \varnothing 38 \times 65$	
⑤	000164	1	Nyloc nut M14	
⑥	000391	2	Set bolt M12 x 60 x 1.25	
⑦	011096	4	Plain washer M12	
⑧	011086	2	Nyloc nut M12 x 1.25	
⑨	043995	1	Bracket, chassis mounting, position 2, right hand side, VOLVO	388
⑩	000163	1	Bolt M14 x 120	
⑪	000073	2	Plain washer M14	
⑫	034909	1	Spacer $\varnothing 15 \times \varnothing 38 \times 65$	
⑬	000164	1	Nyloc nut M14	
⑭	000391	2	Set bolt M12 x 60 x 1.25	
⑮	011096	4	Plain washer M12	
⑯	011086	2	Nyloc nut M12 x 1.25	



Subframe to chassis mountings, position 3, VOLVO

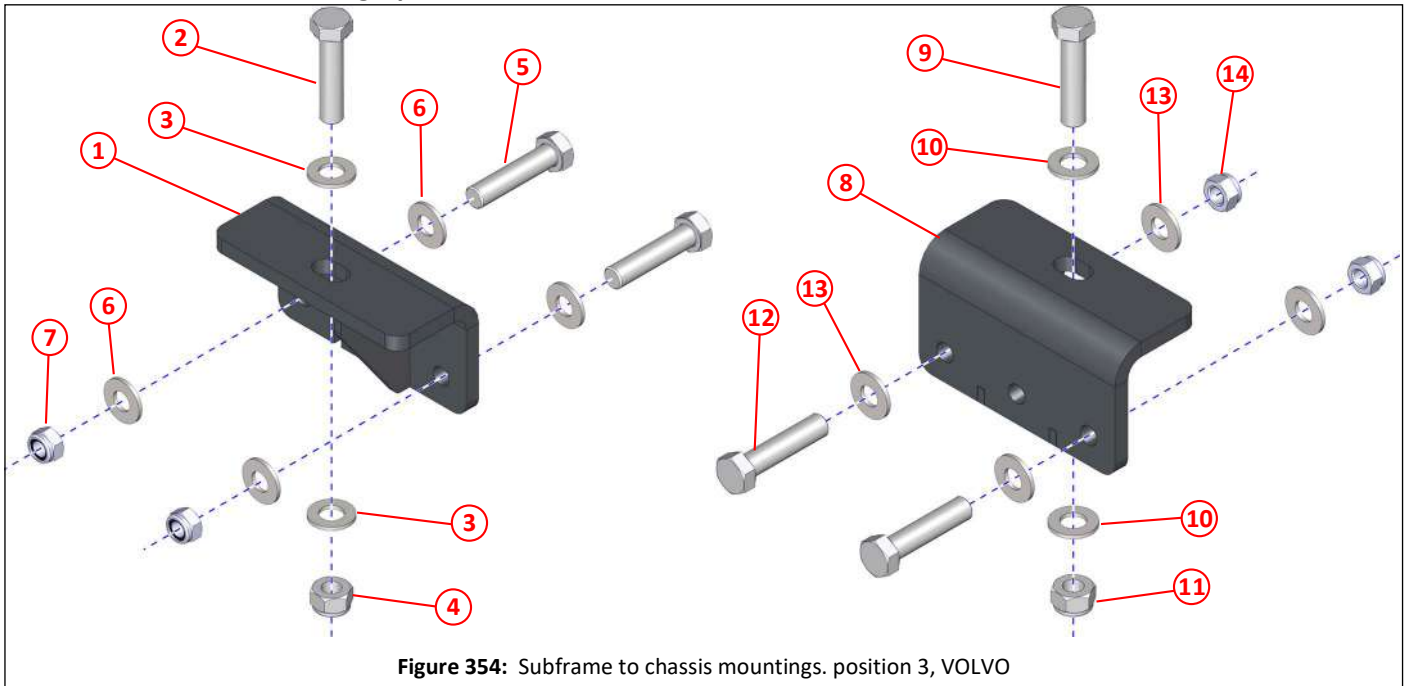

Figure 354: Subframe to chassis mountings. position 3, VOLVO

Item	Part No	Qty	Description	
①	043993	1	Bracket, chassis mounting, position 3, VOLVO	388
②	000204	1	Bolt M14 x 60	
③	000073	2	Plain washer M14	
④	000164	1	Nyloc nut M14	
⑤	000391	2	Bolt M12 x 60 x 1.25	
⑥	011096	4	Plain washer M12	
⑦	011086	2	Nyloc nut M12 x 1.25	
⑧	043993	1	Bracket, chassis mounting, position 3, VOLVO	388
⑨	000204	1	Bolt M14 x 60	
⑩	000073	2	Plain washer M14	
⑪	000164	1	Nyloc nut M14	
⑫	000391	2	Bolt M12 x 60 x 1.25	
⑬	011096	4	Plain washer M12	
⑭	011086	2	Nyloc nut M12 x 1.25	

Subframe to chassis mountings, position 4, VOLVO

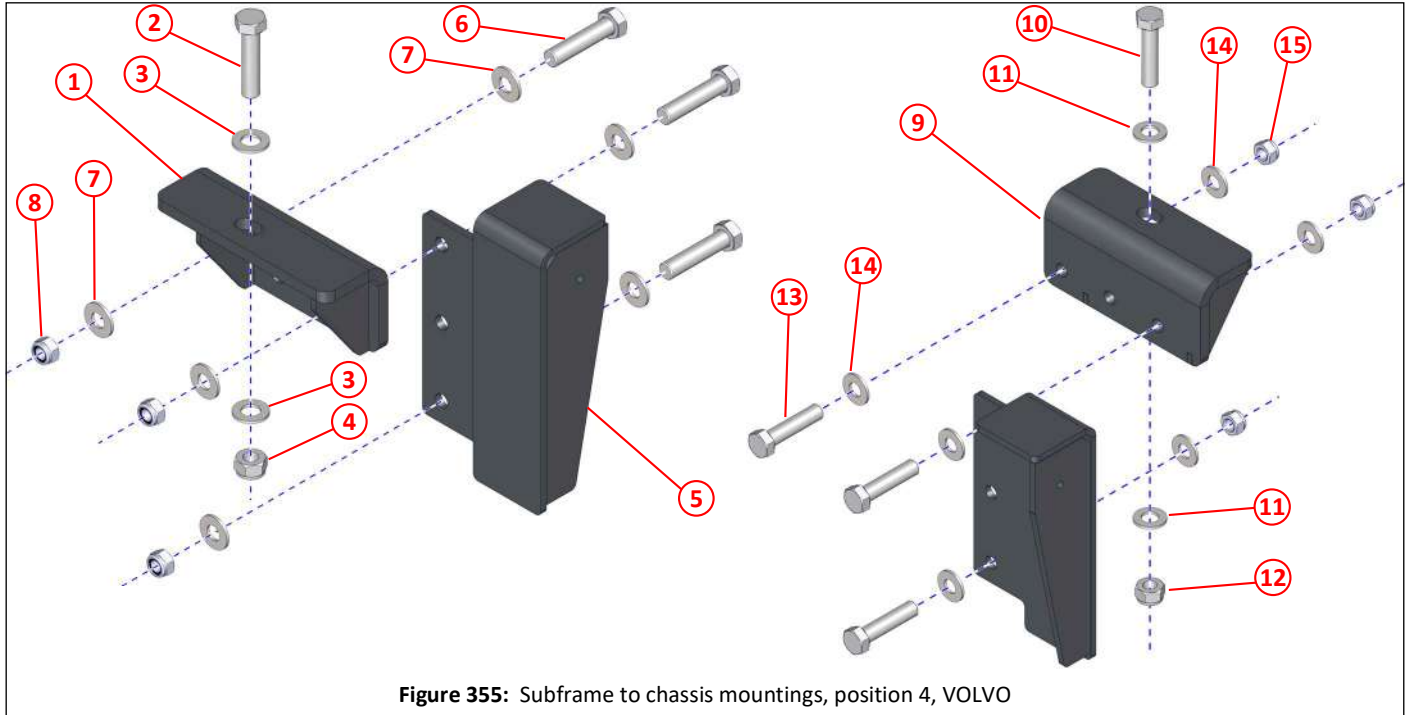

Figure 355: Subframe to chassis mountings, position 4, VOLVO

Item	Part No	Qty	Description	
①	043991	1	Bracket, chassis mounting, position 4, left hand side, VOLVO	388
②	000204	1	Bolt M14 x 60	
③	000073	2	Plain washer M14	
④	000164	1	Nyloc nut M14	
⑤	043989	1	Extension, chassis rail, left hand side, VOLVO	
⑥	000391	3	Bolt M12 x 60 x 1.25	
⑦	011096	6	Plain washer M12	
⑧	011086	3	Nyloc nut M12 x 1.25	
⑨	043992	1	Bracket, chassis mounting, position 4, right hand side, VOLVO	388
⑩	000204	1	Bolt M14 x 60	
⑪	000073	2	Plain washer M14	
⑫	043990	1	Extension, chassis rail, right hand side, VOLVO	
⑬	000164	1	Nyloc nut M14	
⑭	000391	3	Bolt M12 x 60 x 1.25	
⑮	011096	6	Plain washer M12	
⑯	011086	3	Nyloc nut M12 x 1.25	

Subframe to chassis mountings lateral support, left side, VOLVO

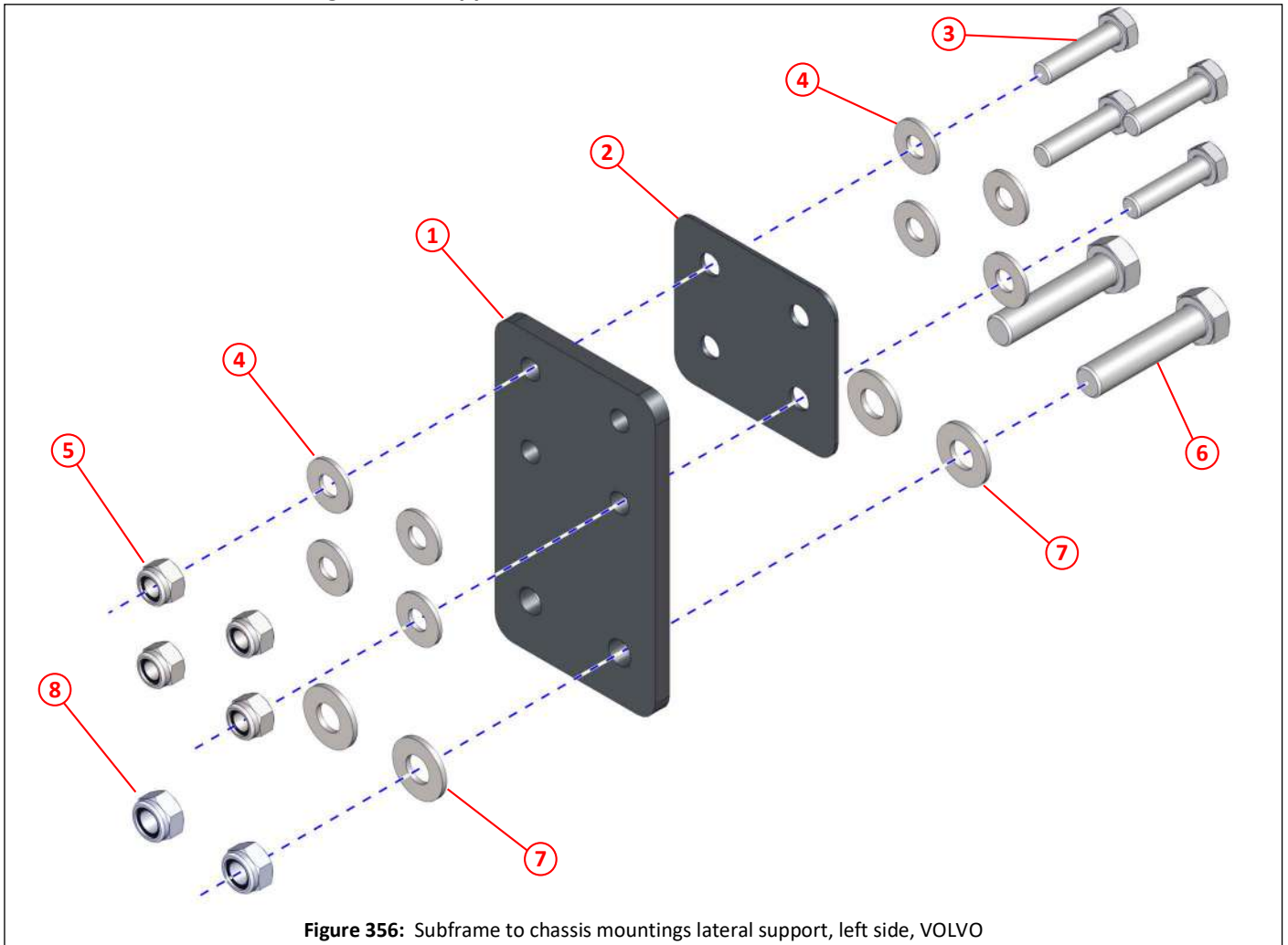

Figure 356: Subframe to chassis mountings lateral support, left side, VOLVO

Item	Part No	Qty	Description
①	040356	1	Bracket, lateral support, rear
②	041309	1	Packer, subframe lateral support
③	011034	4	Set screw M10 x 40
④	011094	8	Plain washer M10
⑤	011075	4	Nyloc nut M10
⑥	000391	2	Bolt M12 x 60 x 1.25
⑦	011096	4	Plain washer M12
⑧	011086	2	Nyloc nut M12 x 1.25

Subframe to chassis mountings lateral support, right side, VOLVO

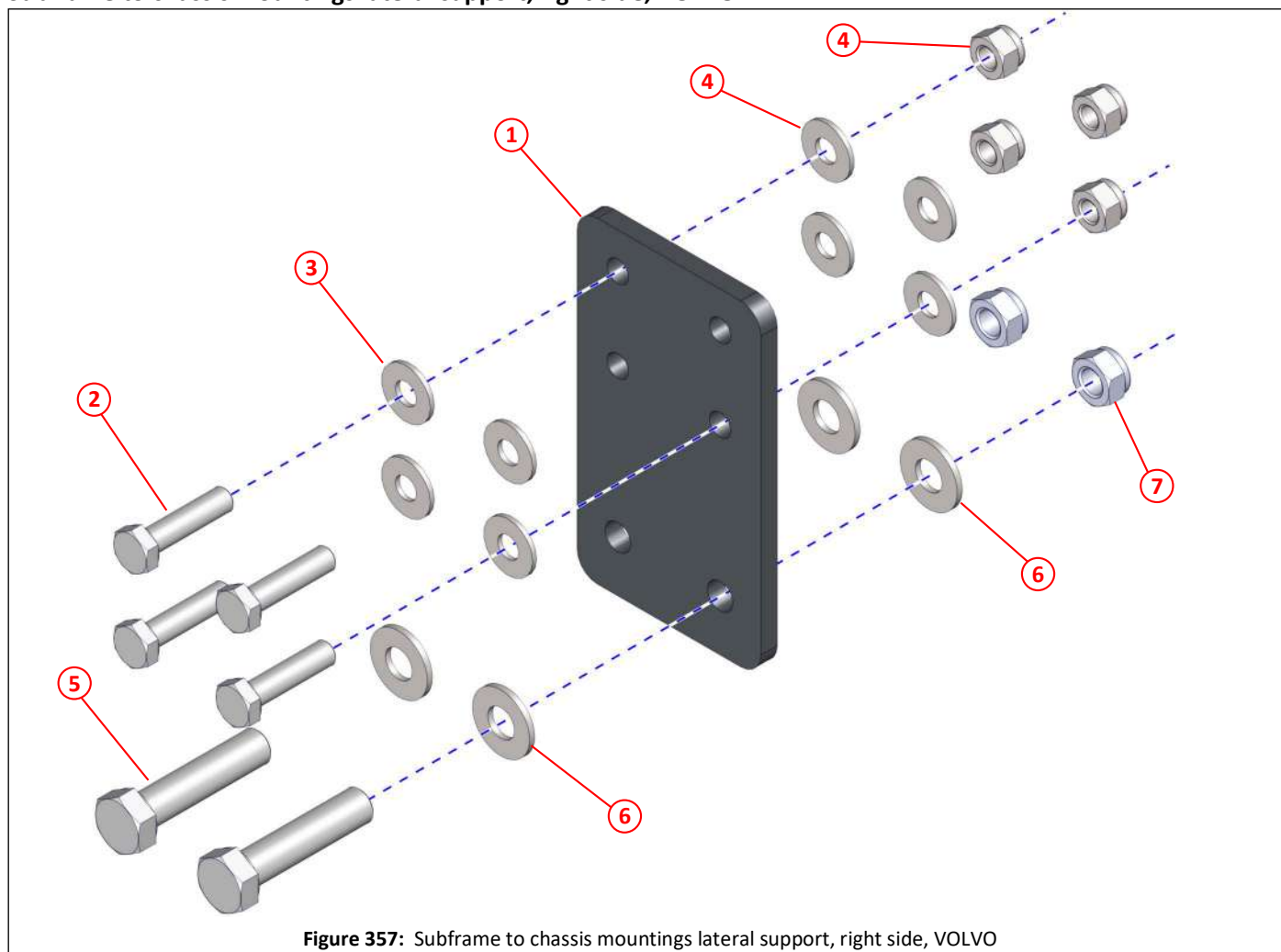

Figure 357: Subframe to chassis mountings lateral support, right side, VOLVO

Item	Part No	Qty	Description
①	040356	1	Bracket, lateral support, rear
②	011034	4	Set screw M10 x 40
③	011094	8	Plain washer M10
④	011075	4	Nyloc nut M10
⑤	000391	2	Bolt M12 x 60 x 1.25
⑥	011096	4	Plain washer M12
⑦	011086	2	Nyloc nut M12 x 1.25

Subframe to chassis mountings, IVECO

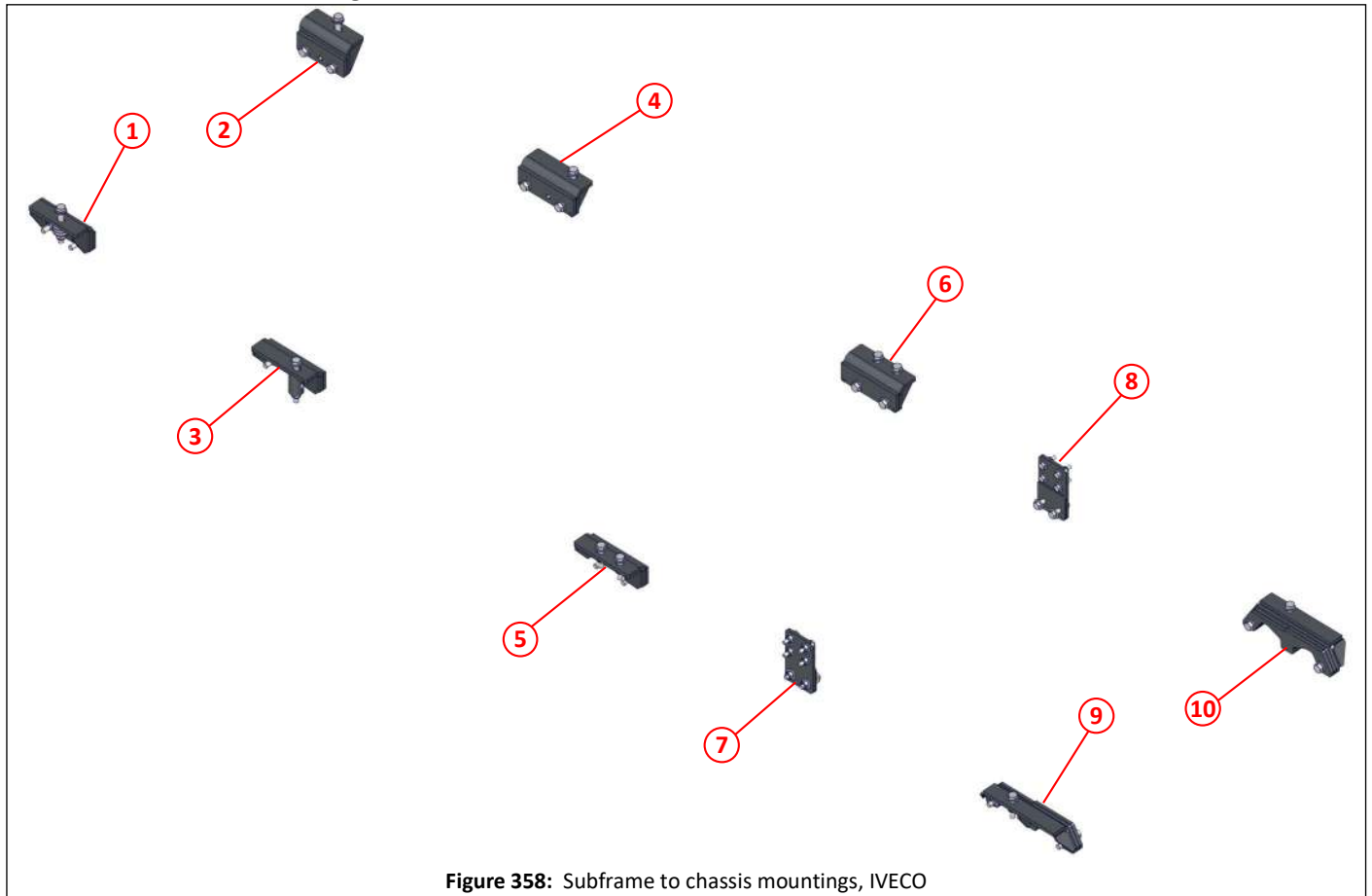

Figure 358: Subframe to chassis mountings, IVECO

Item	Part No	Qty	Description	
①	045188	1	Chassis mounting bracket, position 1, left hand side, IVECO	396
②	045189	1	Chassis mounting bracket, position 1, right hand side, IVECO	396
③	045190	1	Chassis mounting bracket, position 2, left hand side, IVECO	397
④	045191	1	Chassis mounting bracket, position 2, right hand side, IVECO	397
⑤	045192	1	Chassis mounting bracket, position 3, left hand side, IVECO	398
⑥	045193	1	Chassis mounting bracket, position 3, right hand side, IVECO	398
⑦		1	Chassis lateral support, left hand side	400
⑧		1	Chassis lateral support, right hand side	401
⑨	034605	1	Chassis mounting bracket, position 4, left hand side, IVECO	399
⑩	034606	1	Chassis mounting bracket, position 4, right hand side, IVECO	399

**i** Please note that fixings shown are 'standard' and your actual sweeper may have different bolts, nuts and washers etc. than what is depicted. Quantities may also vary.

The chassis mounting brackets shown are for specific manufacturer's chassis.

Please always contact Scarab Parts Department when needing to order mounting brackets and fixings with your sweepers Works No. to ensure we match what was originally supplied.

Subframe to chassis mountings, position 1, IVECO

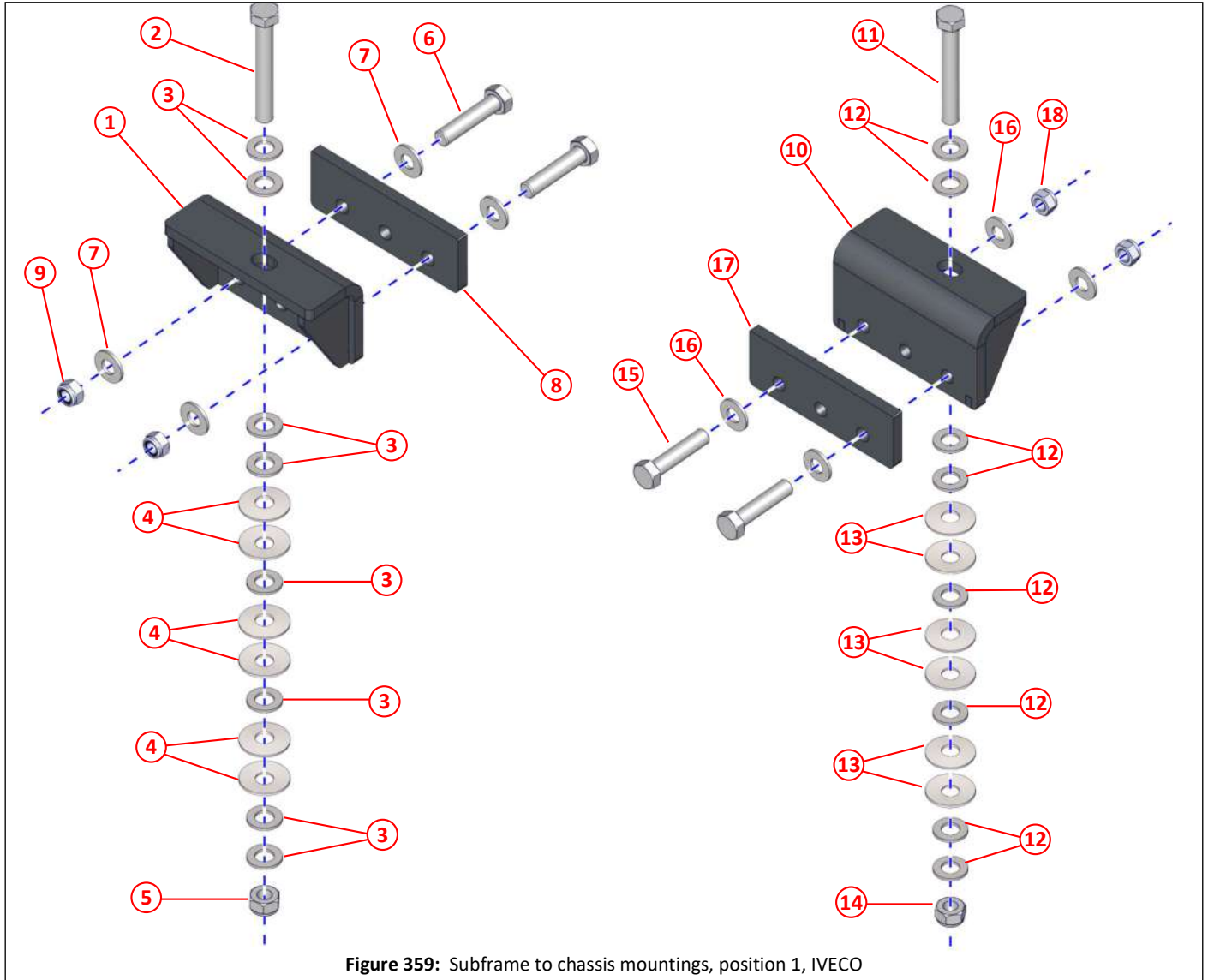

Figure 359: Subframe to chassis mountings, position 1, IVECO

Item	Part No	Qty	Description	
①	045188	1	Bracket, chassis mounting, position 1, left hand side, IVECO	395
②	000102	1	Bolt M14 x 100	
③	000073	8	Plain washer M14	
④	036824	6	Spring, disc	
⑤	000164	1	Nyloc nut M14	
⑥	000204	2	Set bolt M12 x 60 x 1.25	
⑦	011096	4	Plain washer M12	
⑧	045194	1	Packer, chassis mounting bracket, position 1	
⑨	011086	2	Nyloc nut M12 x 1.25	
⑩	045189	1	Bracket, chassis mounting, position 1, right hand side, IVECO	395
⑪	000102	1	Bolt M14 x 100	
⑫	000073	8	Plain washer M14	
⑬	036824	6	Spring, disc	
⑭	000164	1	Nyloc nut M14	
⑮	000204	2	Set bolt M12 x 60 x 1.25	
⑯	011096	4	Plain washer M12	
⑰	045194	1	Packer, chassis mounting bracket, position 1	
⑱	011086	2	Nyloc nut M12 x 1.25	



Subframe to chassis mountings, position 2, IVECO

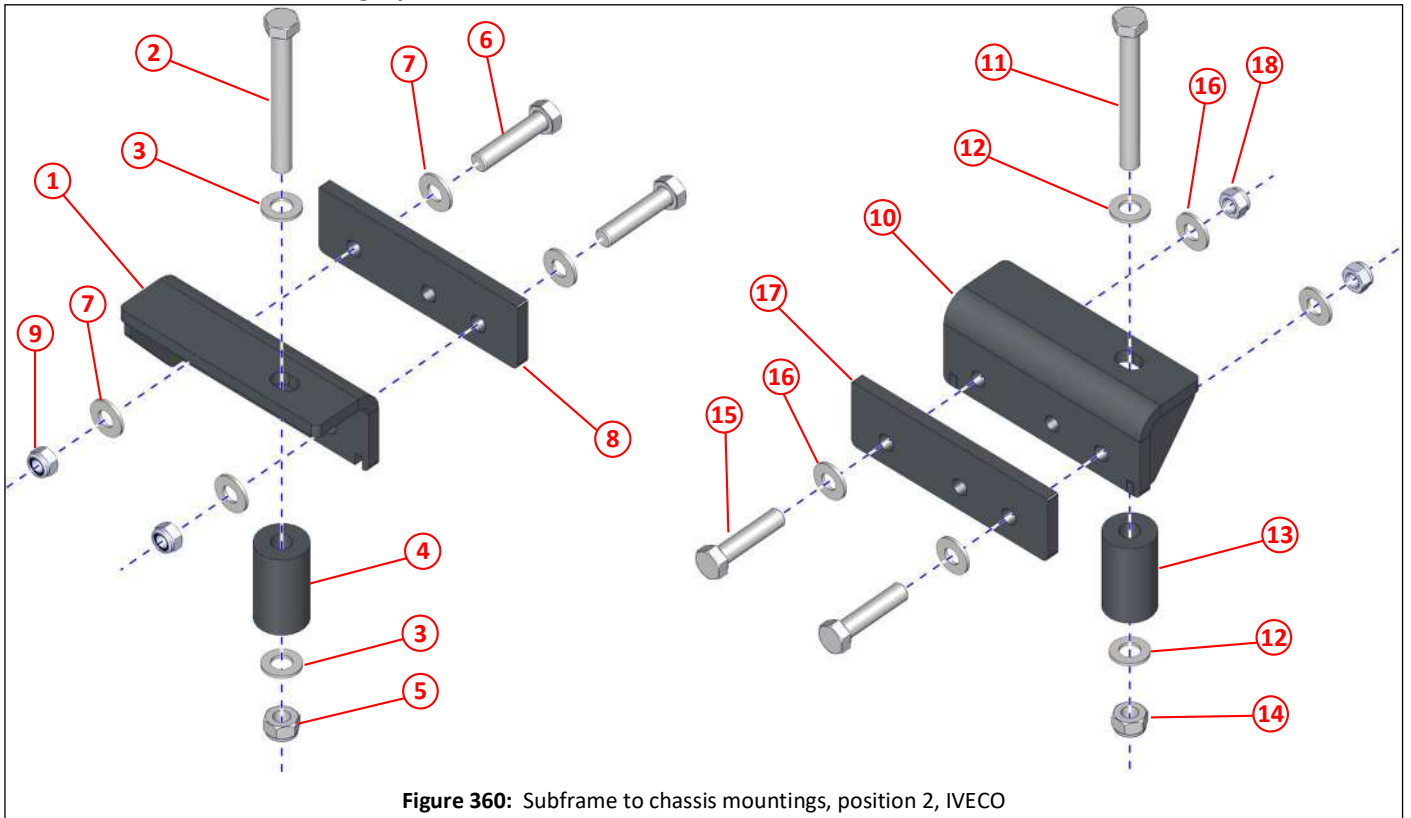

Figure 360: Subframe to chassis mountings, position 2, IVECO

Item	Part No	Qty	Description	
①	045190	1	Bracket, chassis mounting, position 2, left hand side, VOLVO	395
②	000163	1	Bolt M14 x 120	
③	000073	2	Plain washer M14	
④	034909	1	Spacer $\phi 15 \times \phi 38 \times 65$	
⑤	000164	1	Nyloc nut M14	
⑥	000391	2	Set bolt M12 x 60 x 1.25	
⑦	011096	4	Plain washer M12	
⑧	045195	1	Packer, chassis mounting bracket, position 2	
⑨	011086	2	Nyloc nut M12 x 1.25	
⑩	045191	1	Bracket, chassis mounting, position 2, right hand side, VOLVO	395
⑪	000163	1	Bolt M14 x 120	
⑫	000073	2	Plain washer M14	
⑬	034909	1	Spacer $\phi 15 \times \phi 38 \times 65$	
⑭	000164	1	Nyloc nut M14	
⑮	000391	2	Set bolt M12 x 60 x 1.25	
⑯	011096	4	Plain washer M12	
⑰	045195	1	Packer, chassis mounting bracket, position 2	
⑱	011086	2	Nyloc nut M12 x 1.25	

## Subframe to chassis mountings, position 3, IVECO

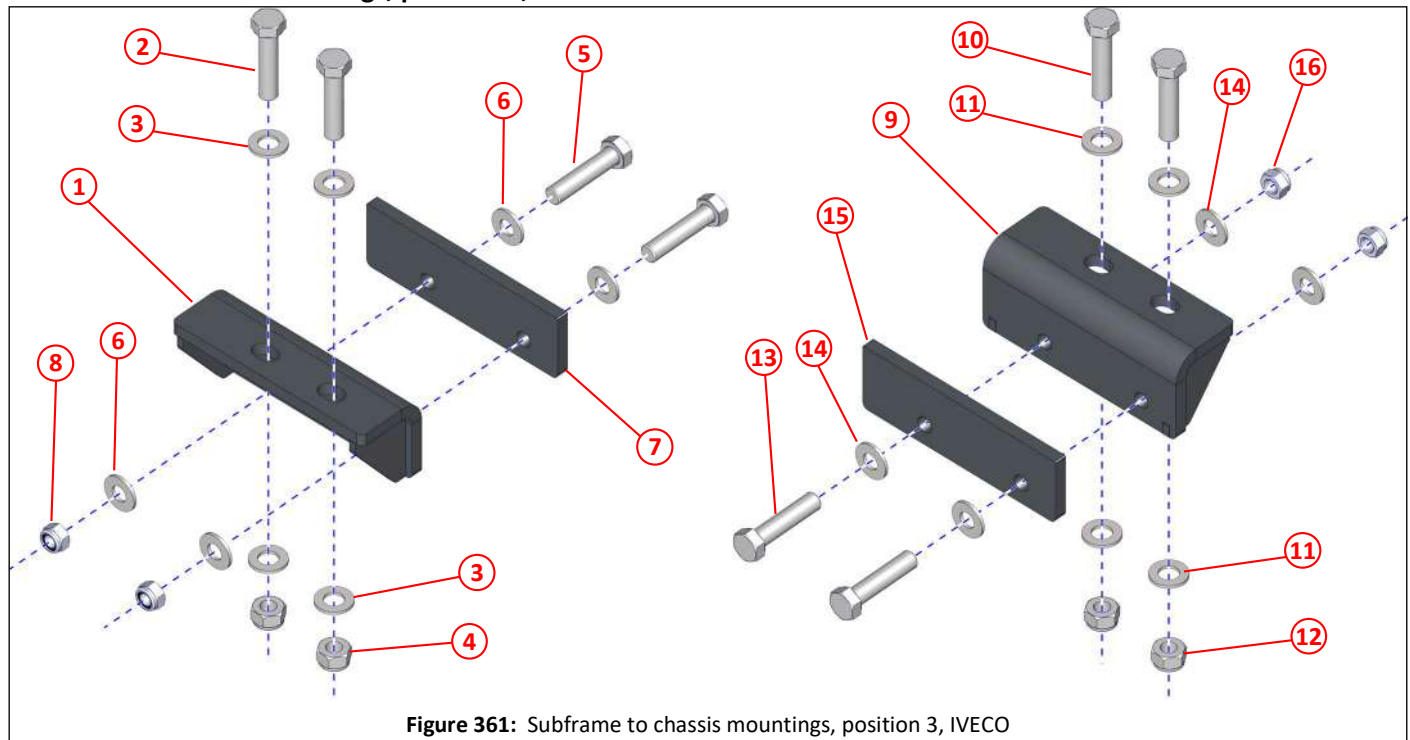

Figure 361: Subframe to chassis mountings, position 3, IVECO

Item	Part No	Qty	Description	
①	045192	1	Bracket, chassis mounting, position 3, left hand side, IVECO	395
②	000204	2	Bolt M14 x 60	
③	000073	4	Plain washer M14	
④	000164	2	Nyloc nut M14	
⑤	000391	2	Set bolt M12 x 60 x 1.25	
⑥	011096	4	Plain washer M12	
⑦	045196	1	Packer, chassis mounting bracket, position 3	
⑧	011086	2	Nyloc nut M12 x 1.25	
⑨	045193	1	Bracket, chassis mounting, position 3, right hand side, IVECO	395
⑩	000204	2	Bolt M14 x 60	
⑪	000073	3	Plain washer M14	
⑫	000164	4	Nyloc nut M14	
⑬	000391	2	Set bolt M12 x 60 x 1.25	
⑭	011096	4	Plain washer M12	
⑮	045196	1	Packer, chassis mounting bracket, position 3	
⑯	011086	2	Nyloc nut M12 x 1.25	

Subframe to chassis mountings, position 4, IVECO

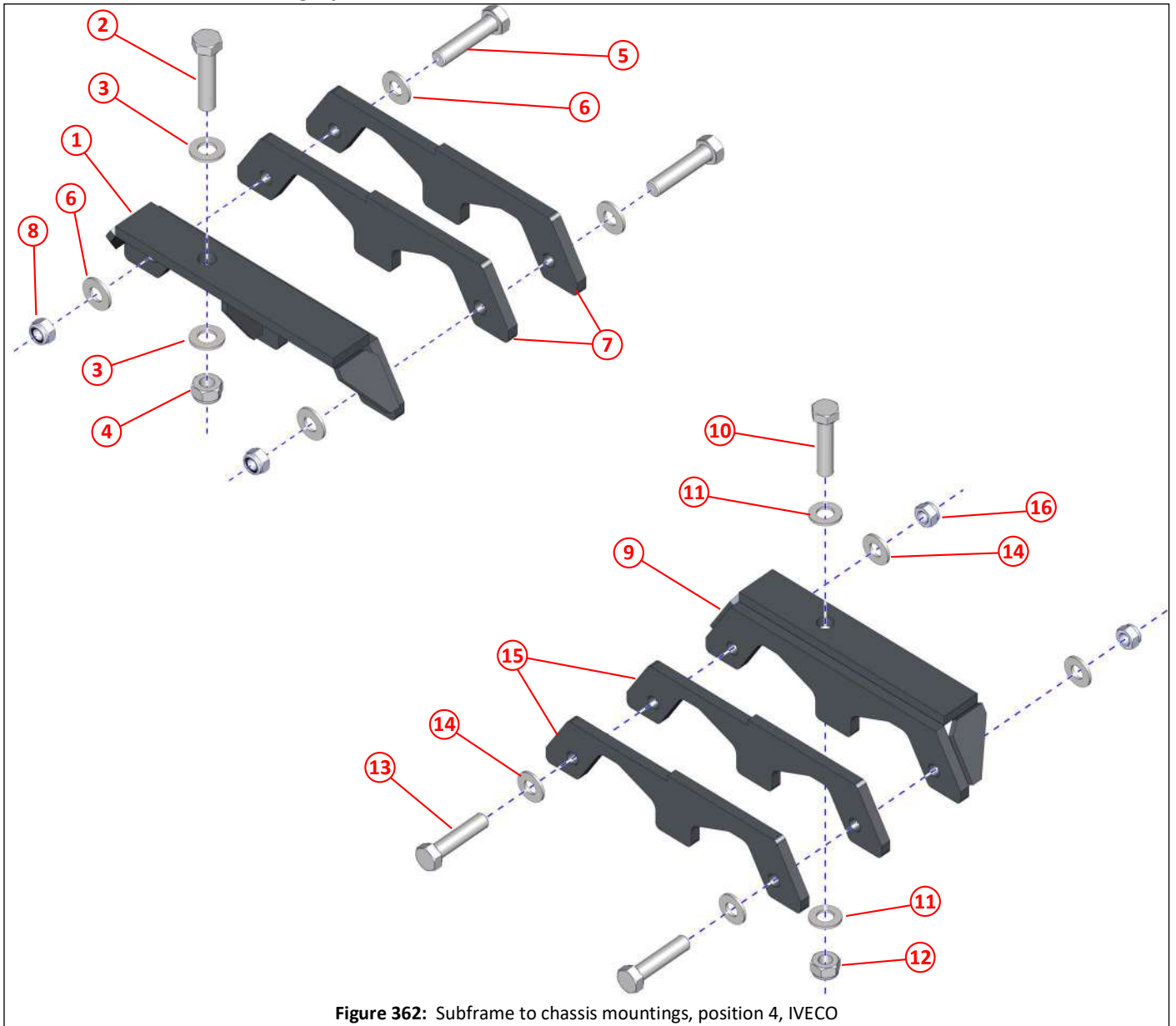

Figure 362: Subframe to chassis mountings, position 4, IVECO

Item	Part No	Qty	Description	
①	034605	1	Bracket, chassis mounting, position 4, left hand side, IVECO	395
②	000204	1	Bolt M14 x 60	
③	000073	2	Plain washer M14	
④	000164	1	Nyloc nut M14	
⑤	000391	2	Set bolt M12 x 60 x 1.25	
⑥	011096	4	Plain washer M12	
⑦	034607	2	Packer, chassis mounting bracket, position 3	
⑧	011086	2	Nyloc nut M12 x 1.25	
⑨	034606	1	Bracket, chassis mounting, position 4, right hand side, IVECO	395
⑩	000204	1	Bolt M14 x 60	
⑪	000073	2	Plain washer M14	
⑫	000164	1	Nyloc nut M14	
⑬	000391	2	Set bolt M12 x 60 x 1.25	
⑭	011096	4	Plain washer M12	
⑮	034607	2	Packer, chassis mounting bracket, position 3	
⑯	011086	2	Nyloc nut M12 x 1.25	

## Subframe to chassis mountings lateral support, left side, IVECO

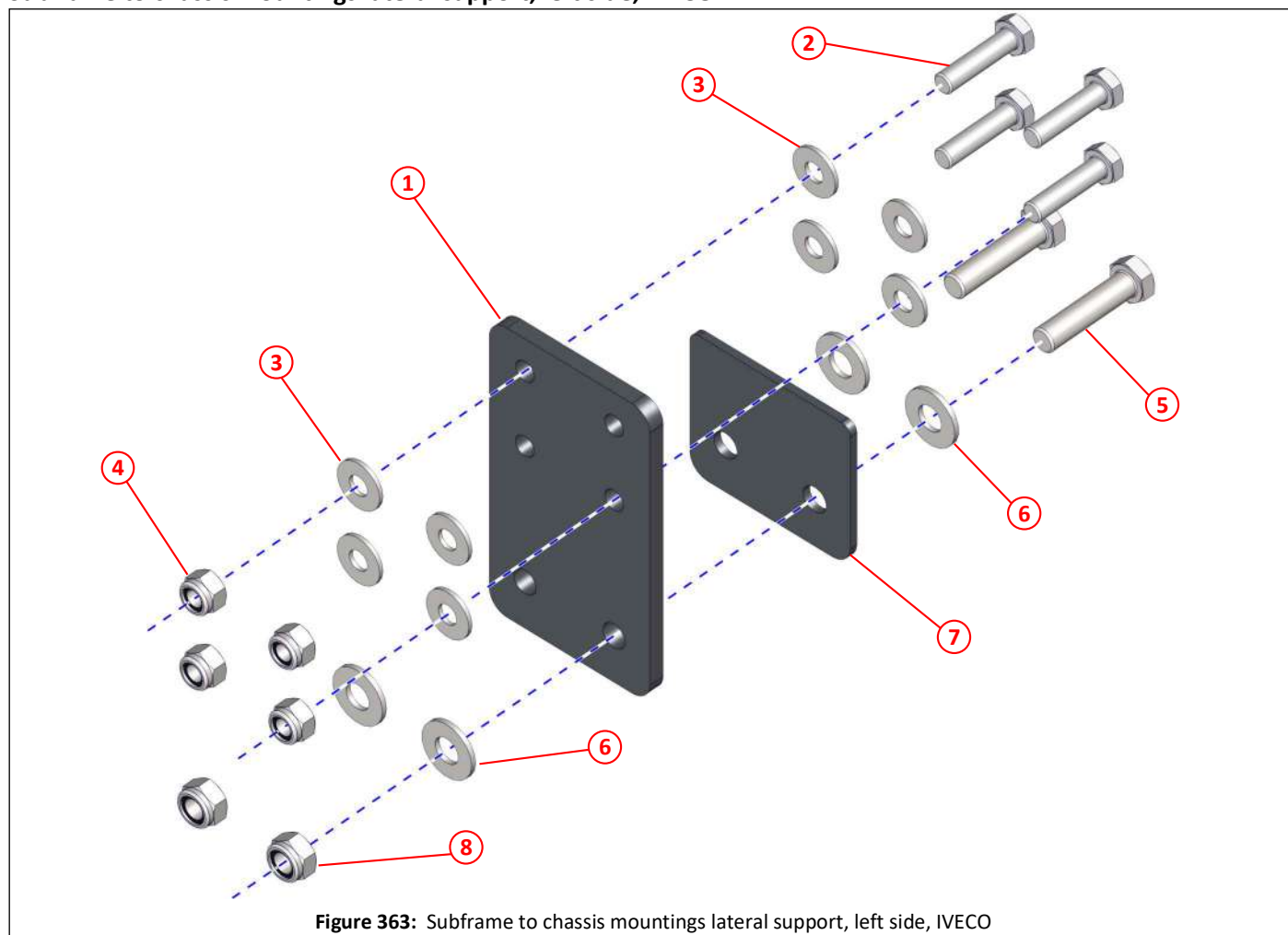

Figure 363: Subframe to chassis mountings lateral support, left side, IVECO

Item	Part No	Qty	Description
①	040356	1	Bracket, lateral support, rear
②	011034	4	Set screw M10 x 40
③	011094	8	Plain washer M10
④	011075	4	Nyloc nut M10
⑤	000391	2	Bolt M12 x 60 x 1.25
⑥	011096	4	Plain washer M12
⑦	045200	1	Packer, lateral support, rear, IVECO
⑧	011086	2	Nyloc nut M12 x 1.25

Subframe to chassis mountings lateral support, right side, IVECO

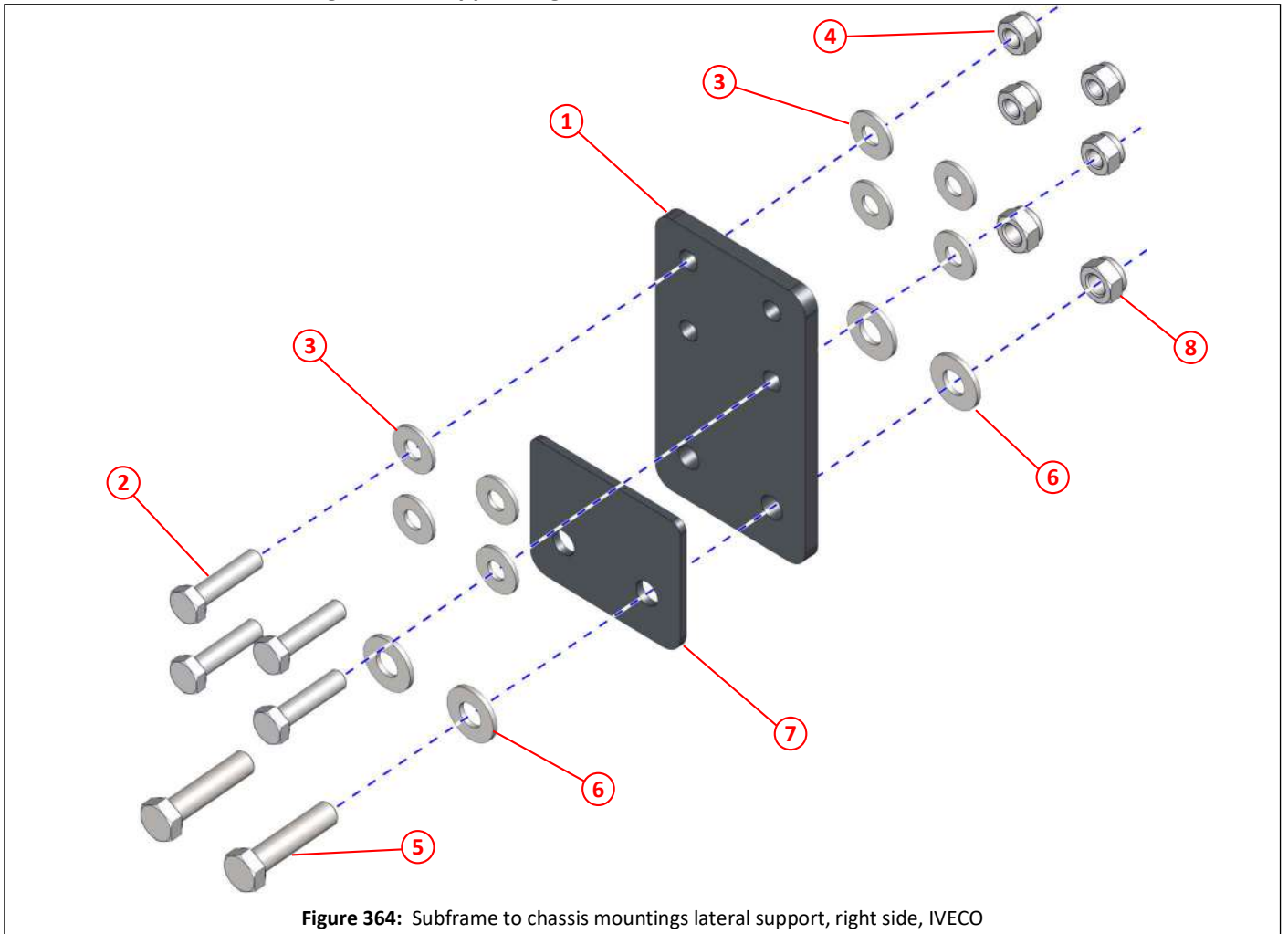

Figure 364: Subframe to chassis mountings lateral support, right side, IVECO

Item	Part No	Qty	Description
①	040356	1	Bracket, lateral support, rear
②	011034	4	Set screw M10 x 40
③	011094	8	Plain washer M10
④	011075	4	Nyloc nut M10
⑤	000391	2	Bolt M12 x 60 x 1.25
⑥	011096	4	Plain washer M12
⑦	045200	1	Packer, lateral support, rear, IVECO
⑧	011086	2	Nyloc nut M12 x 1.25

## Subframe to chassis mountings, Mercedes

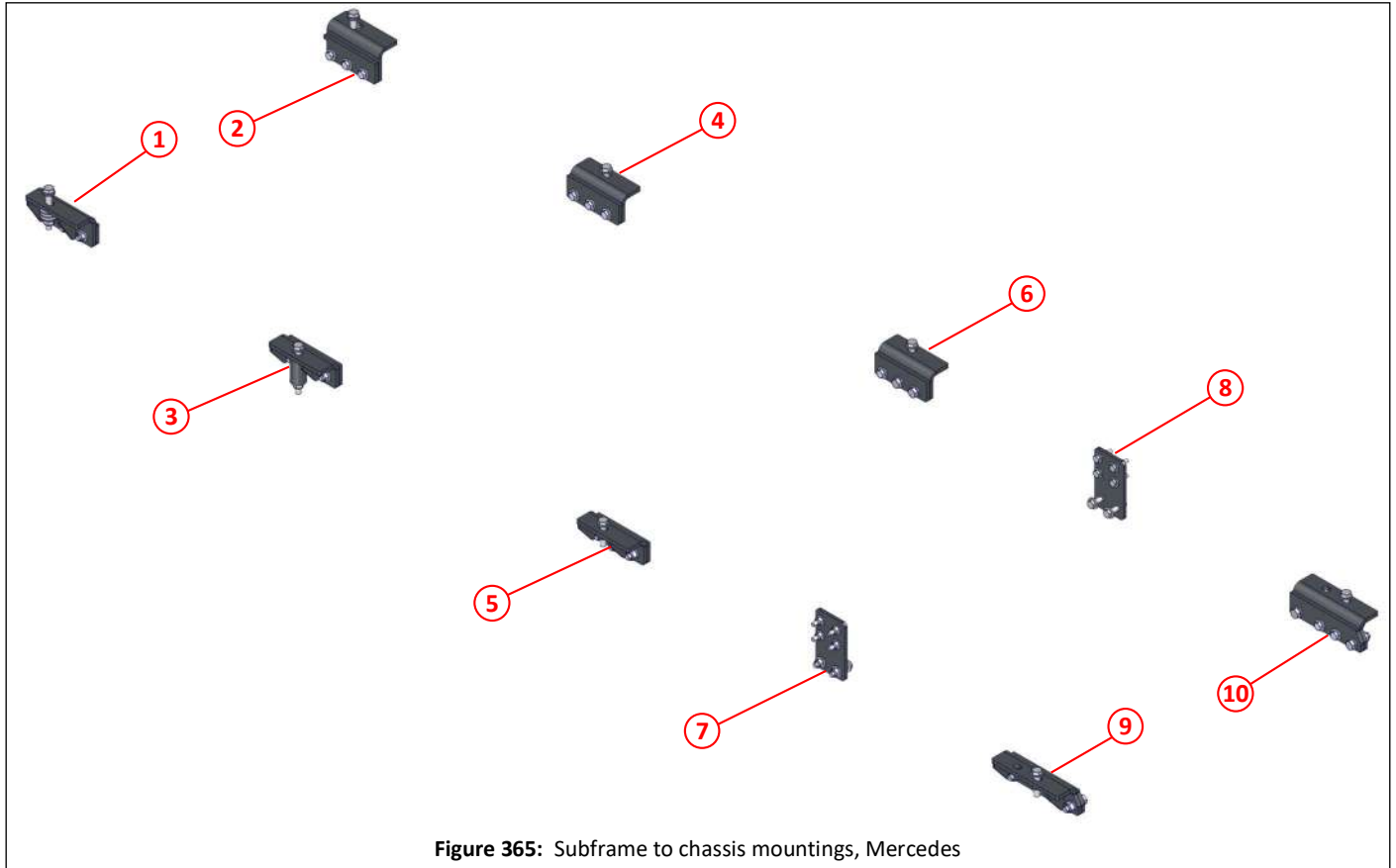

Figure 365: Subframe to chassis mountings, Mercedes

Item	Part No	Qty	Description	
①	045328	1	Chassis mounting bracket, position 1, left hand side, Mercedes	403
②	045239	1	Chassis mounting bracket, position 1, right hand side, Mercedes	403
③	045240	1	Chassis mounting bracket, position 2, left hand side, Mercedes	404
④	045241	1	Chassis mounting bracket, position 2, right hand side, Mercedes	404
⑤	045242	1	Chassis mounting bracket, position 3, left hand side, Mercedes	405
⑥	045243	1	Chassis mounting bracket, position 3, right hand side, Mercedes	405
⑦		1	Chassis lateral support, left hand side	400
⑧		1	Chassis lateral support, right hand side	408
⑨	045244	1	Chassis mounting bracket, position 4, left hand side, Mercedes	406
⑩	045245	1	Chassis mounting bracket, position 4, right hand side, Mercedes	406

**i** Please note that fixings shown are 'standard' and your actual sweeper may have different bolts, nuts and washers etc. than what is depicted. Quantities may also vary.  
The chassis mounting brackets shown are for specific manufacturer's chassis.

Please always contact Scarab Parts Department when needing to order mounting brackets and fixings with your sweepers Works No. to ensure we match what was originally supplied.



Subframe to chassis mountings, position 1, Mercedes

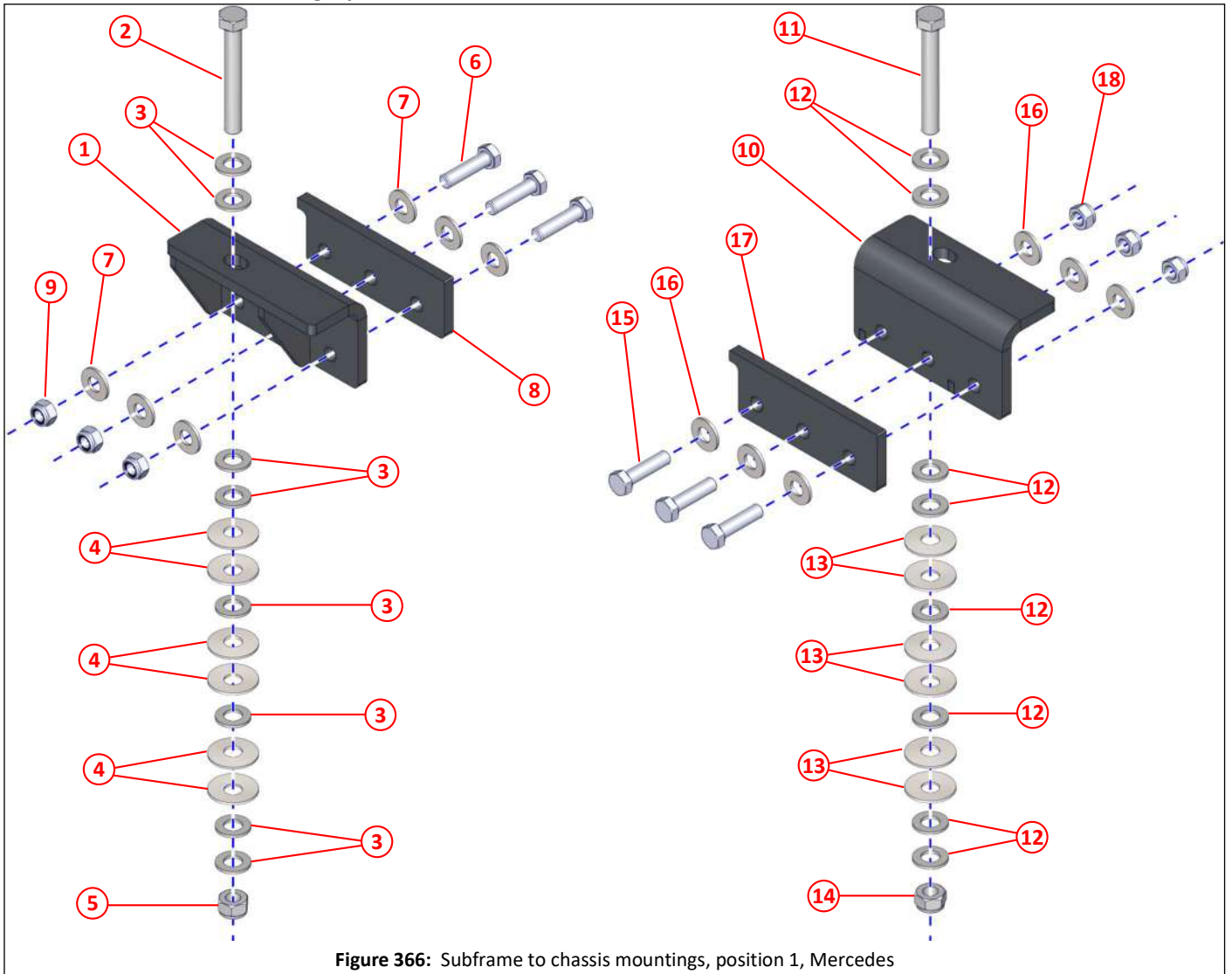

Figure 366: Subframe to chassis mountings, position 1, Mercedes

Item	Part No	Qty	Description	
①	045238	1	Bracket, chassis mounting, position 1, right hand side, Mercedes	402
②	000102	1	Bolt M14 x 100	
③	000073	8	Plain washer M14	
④	036824	6	Spring, disc	
⑤	000164	1	Nyloc nut M14	
⑥	000128	3	Set bolt M12 x 45 x 1.25	
⑦	011096	6	Plain washer M12	
⑧	045246	1	Packer, chassis mounting bracket, position 1	
⑨	011086	3	Nyloc nut M12 x 1.25	
⑩	045239	1	Bracket, chassis mounting, position 1, right hand side, Mercedes	402
⑪	000102	1	Bolt M14 x 100	
⑫	000073	8	Plain washer M14	
⑬	036824	6	Spring, disc	
⑭	000164	1	Nyloc nut M14	
⑮	000204	3	Set bolt M12 x 60 x 1.25	
⑯	011096	6	Plain washer M12	
⑰	045194	1	Packer, chassis mounting bracket, position 1	
⑱	011086	3	Nyloc nut M12 x 1.25	

Subframe to chassis mountings, position 2, Mercedes

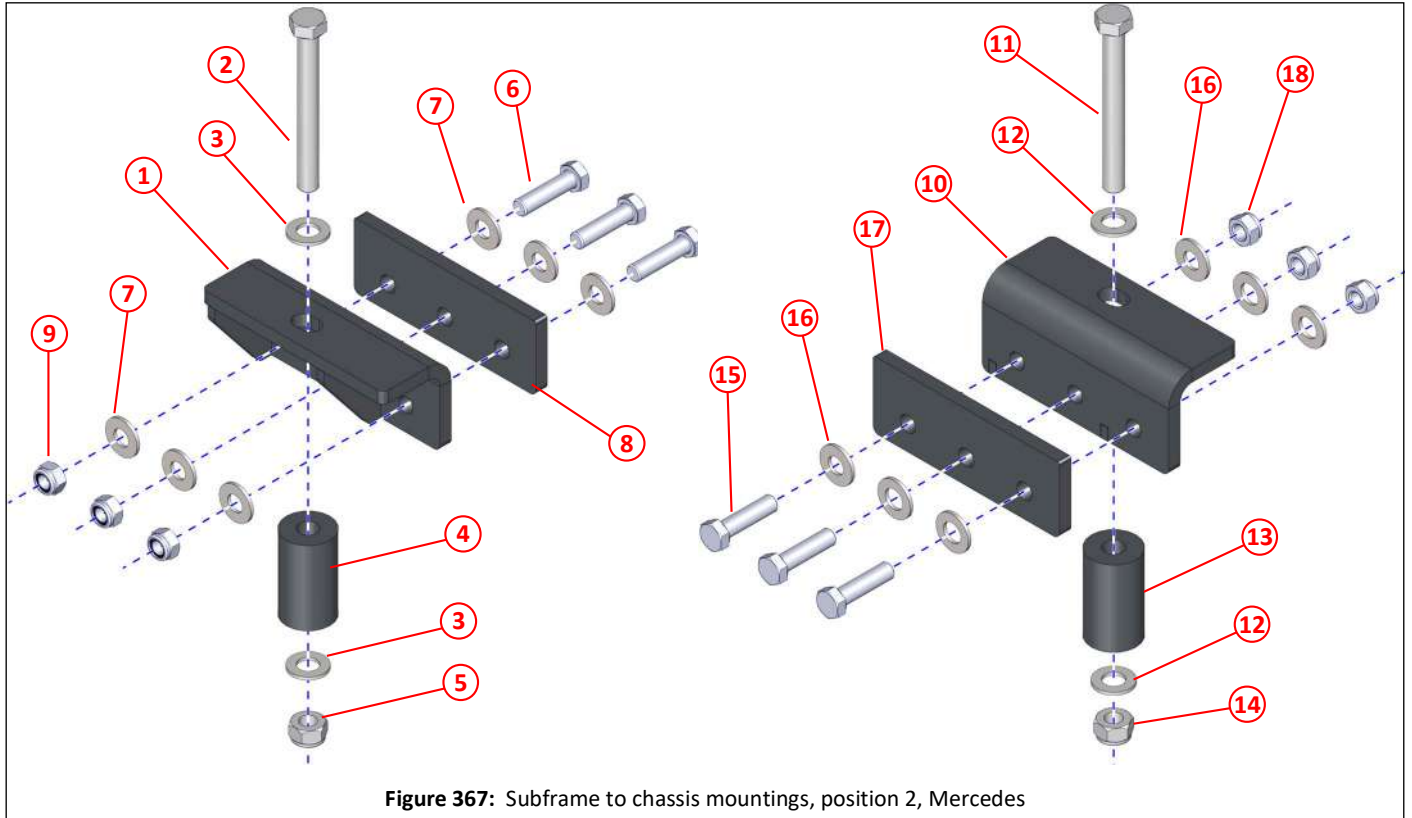

Figure 367: Subframe to chassis mountings, position 2, Mercedes

Item	Part No	Qty	Description	
①	045240	1	Bracket, chassis mounting, position 2, left hand side, Mercedes	402
②	000163	1	Bolt M14 x 120	
③	000073	2	Plain washer M14	
④	034909	1	Spacer $\varnothing 15 \times \varnothing 38 \times 65$	
⑤	000164	1	Nyloc nut M14	
⑥	000128	3	Set bolt M12 x 45 x 1.25	
⑦	011096	6	Plain washer M12	
⑧	045247	1	Packer, chassis mounting bracket, position 2, Mercedes	
⑨	011086	3	Nyloc nut M12 x 1.25	
⑩	045241	1	Bracket, chassis mounting, position 2, right hand side, Mercedes	402
⑪	000163	1	Bolt M14 x 120	
⑫	000073	2	Plain washer M14	
⑬	034909	1	Spacer $\varnothing 15 \times \varnothing 38 \times 65$	
⑭	000164	1	Nyloc nut M14	
⑮	000128	3	Set bolt M12 x 45 x 1.25	
⑯	011096	6	Plain washer M12	
⑰	045247	1	Packer, chassis mounting bracket, position 2, Mercedes	
⑱	011086	3	Nyloc nut M12 x 1.25	

Subframe to chassis mountings, position 3, Mercedes

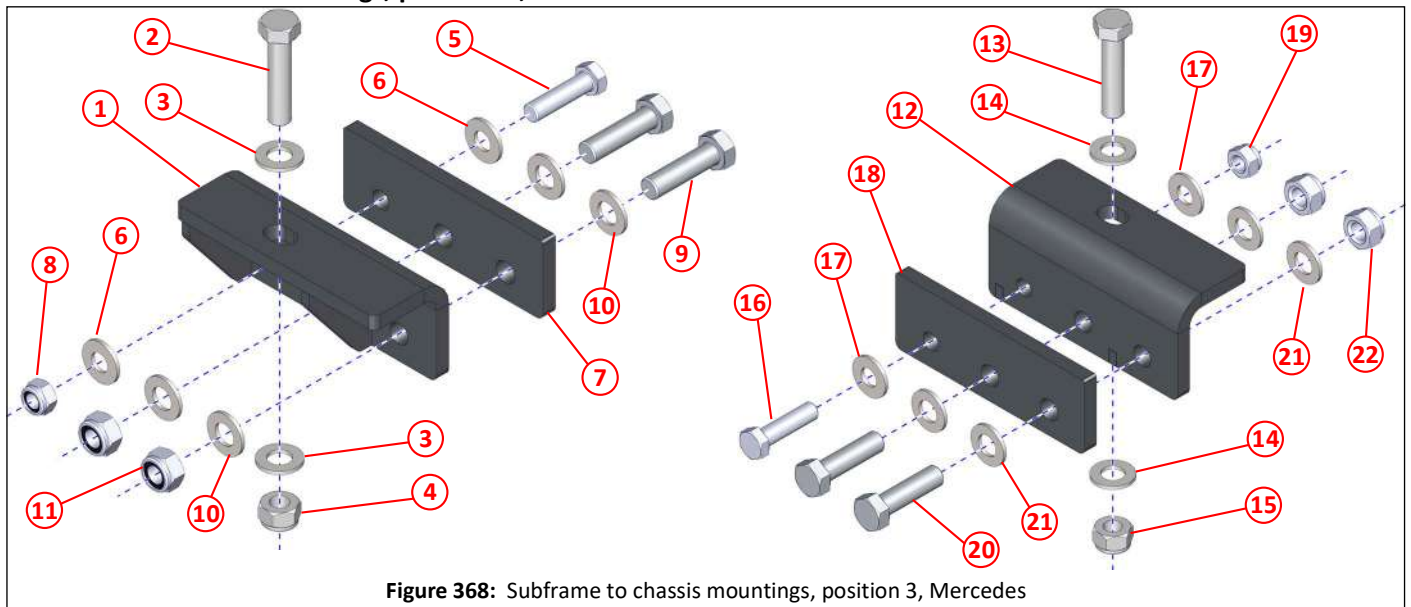

Figure 368: Subframe to chassis mountings, position 3, Mercedes

Item	Part No	Qty	Description	
①	045242	1	Bracket, chassis mounting, position 3, left hand side, Mercedes	402
②	000204	1	Bolt M14 x 60	
③	000073	2	Plain washer M14	
④	000164	1	Nyloc nut M14	
⑤	000128	1	Set bolt M12 x 60 x 1.25	
⑥	011096	2	Plain washer M12	
⑦	045248	1	Packer, chassis mounting bracket, position 3, Mercedes	
⑧	011086	1	Nyloc nut M12 x 1.25	
⑨	000375	2	Set screw M14 x 50 x 10.9	
⑩	000073	4	Plain washer M14	
⑪	000168	2	Nut M14 x 1.5 (fine) Type 'P'	
⑫	045243	1	Bracket, chassis mounting, position 3, right hand side, Mercedes	402
⑬	000204	1	Bolt M14 x 60	
⑭	000073	2	Plain washer M14	
⑮	000164	1	Nyloc nut M14	
⑯	000128	1	Set bolt M12 x 60 x 1.25	
⑰	011096	2	Plain washer M12	
⑱	045248	1	Packer, chassis mounting bracket, position 3, Mercedes	
⑲	011086	1	Nyloc nut M12 x 1.25	
⑳	000375	2	Set screw M14 x 50 x 10.9	
㉑	000073	4	Plain washer M14	
㉒	000168	2	Nut M14 x 1.5 (fine) Type 'P'	

## Subframe to chassis mountings, position 4, Mercedes

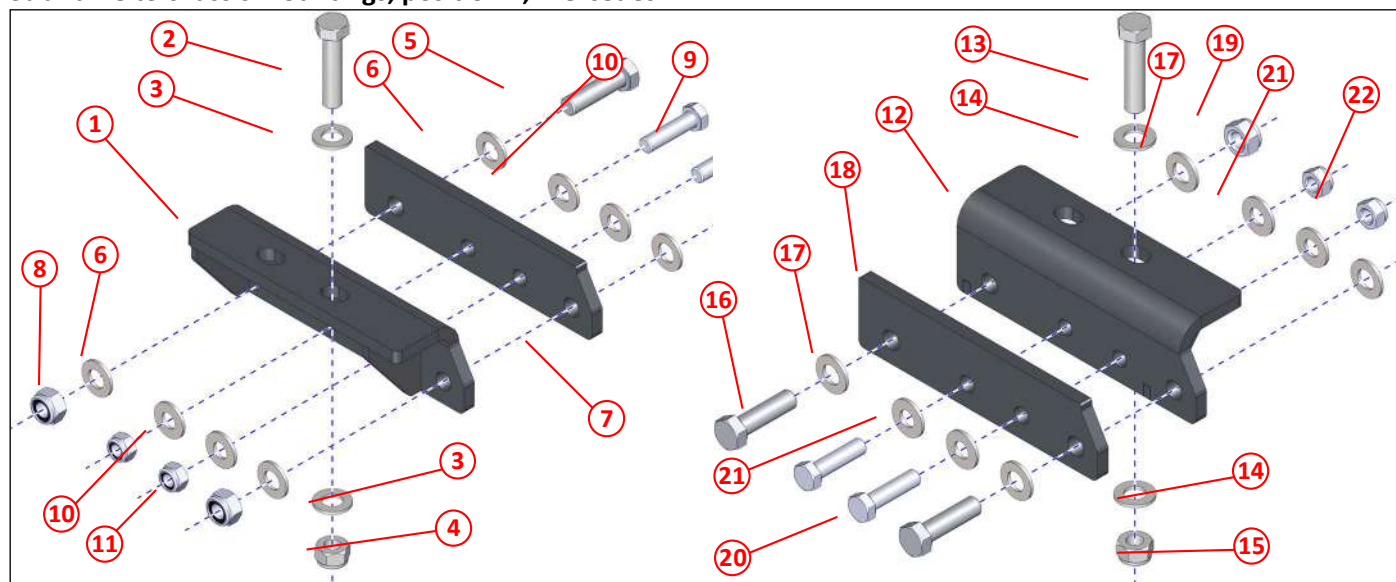

Figure 369: Subframe to chassis mountings, position 4, Mercedes

Item	Part No	Qty	Description	
①	045244	1	Bracket, chassis mounting, position 4, left hand side, Mercedes	402
②	000204	1	Bolt M14 x 60	
③	000073	2	Plain washer M14	
④	000164	1	Nyloc nut M14	
⑤	000375	2	Set screw M14 x 50 x 10.9	
⑥	000073	4	Plain washer M14	
⑦	045249	1	Packer, chassis mounting bracket, position 4, Mercedes	
⑧	000168	2	Nut M14 x 1.5 (fine) Type 'P'	
⑨	000128	1	Set bolt M12 x 60 x 1.25	
⑩	011096	2	Plain washer M12	
⑪	011086	2	Nyloc nut M12 x 1.25	
⑫	045245	1	Bracket, chassis mounting, position 4, right hand side, Mercedes	402
⑬	000204	1	Bolt M14 x 60	
⑭	000073	2	Plain washer M14	
⑮	000164	1	Nyloc nut M14	
⑯	000375	2	Set screw M14 x 50 x 10.9	
⑰	000073	4	Plain washer M14	
⑱	045249	1	Packer, chassis mounting bracket, position 4, Mercedes	
⑲	000168	2	Nut M14 x 1.5 (fine) Type 'P'	
⑳	000128	1	Set bolt M12 x 60 x 1.25	
㉑	011096	2	Plain washer M12	
㉒	011086	2	Nyloc nut M12 x 1.25	

Subframe to chassis mountings lateral support, left side, Mercedes

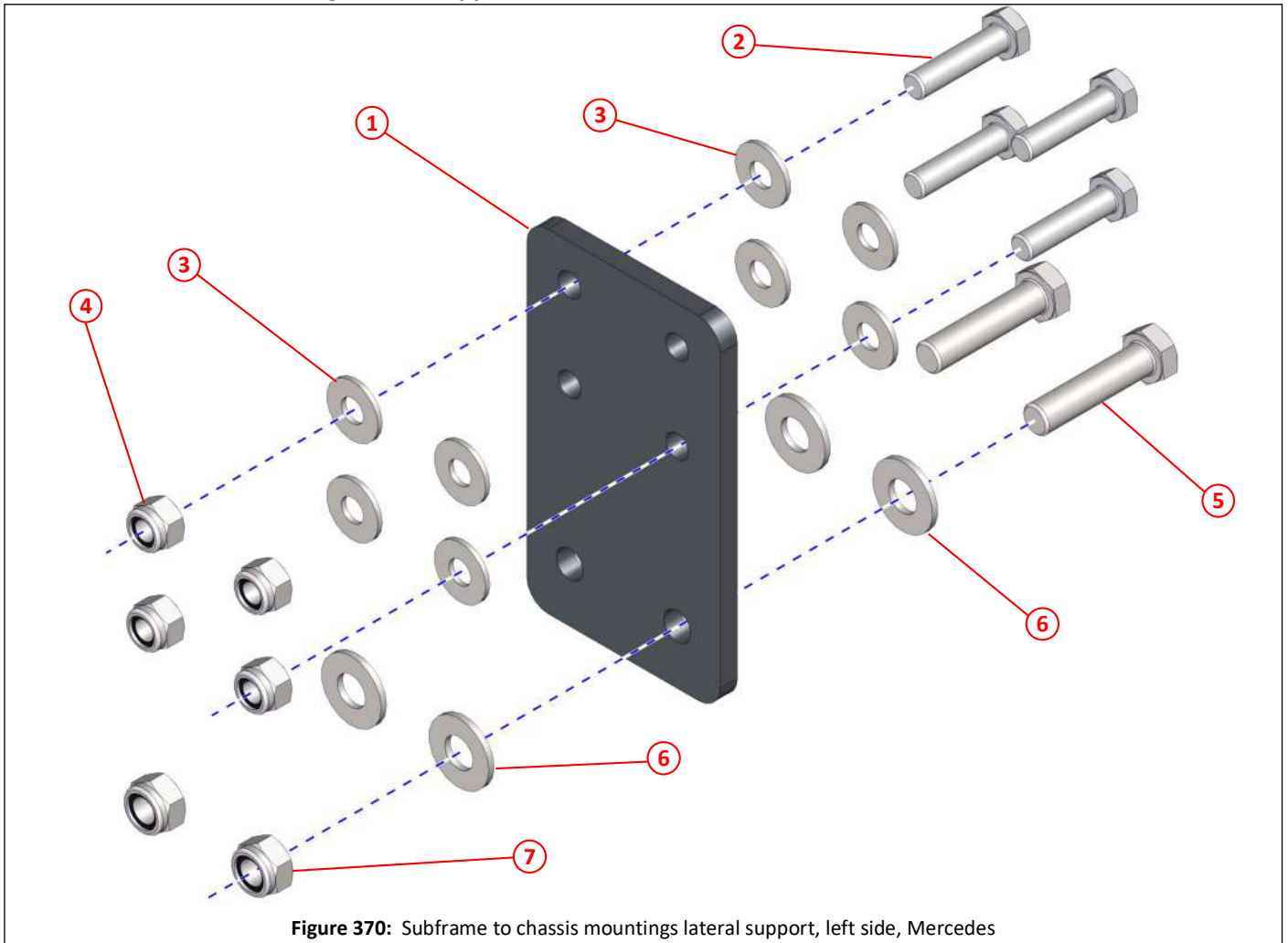

Figure 370: Subframe to chassis mountings lateral support, left side, Mercedes

Item	Part No	Qty	Description	
①	040356	1	Bracket, lateral support, rear	
②	011034	4	Set screw M10 x 40	
③	011094	8	Plain washer M10	
④	011075	4	Nyloc nut M10	
⑤	000024	2	Bolt M12 x 50	
⑥	011096	4	Plain washer M12	
⑦	011077	2	Nyloc nut M12	

Subframe to chassis mountings lateral support, right side, Mercedes

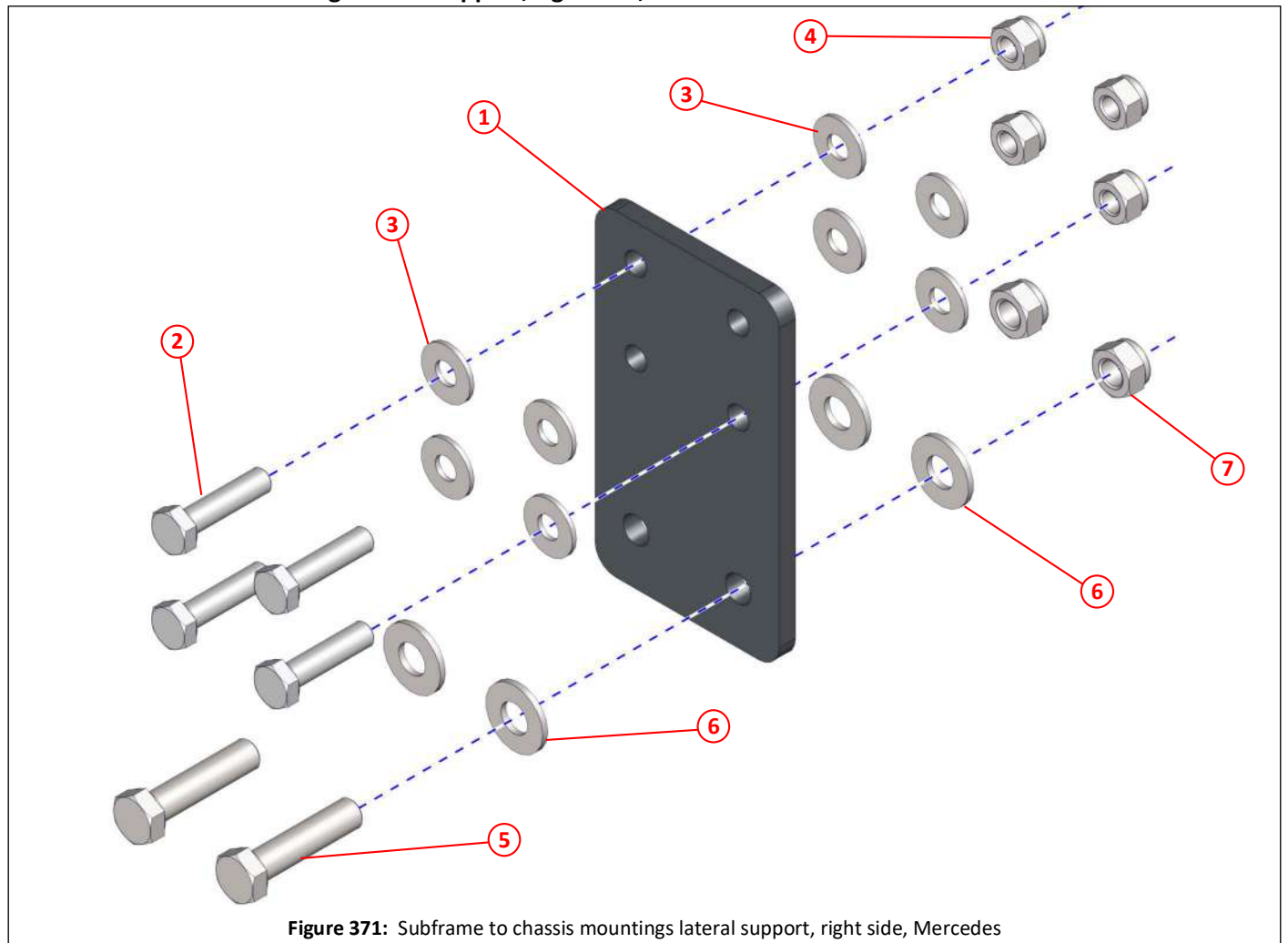

Figure 371: Subframe to chassis mountings lateral support, right side, Mercedes

Item	Part No	Qty	Description
①	040356	1	Bracket, lateral support, rear
②	011034	4	Set screw M10 x 40
③	011094	8	Plain washer M10
④	011075	4	Nyloc nut M10
⑤	000024	2	Bolt M12 x 50
⑥	011096	4	Plain washer M12
⑦	011077	2	Nyloc nut M12



Subframe to chassis mountings MAN 18.290

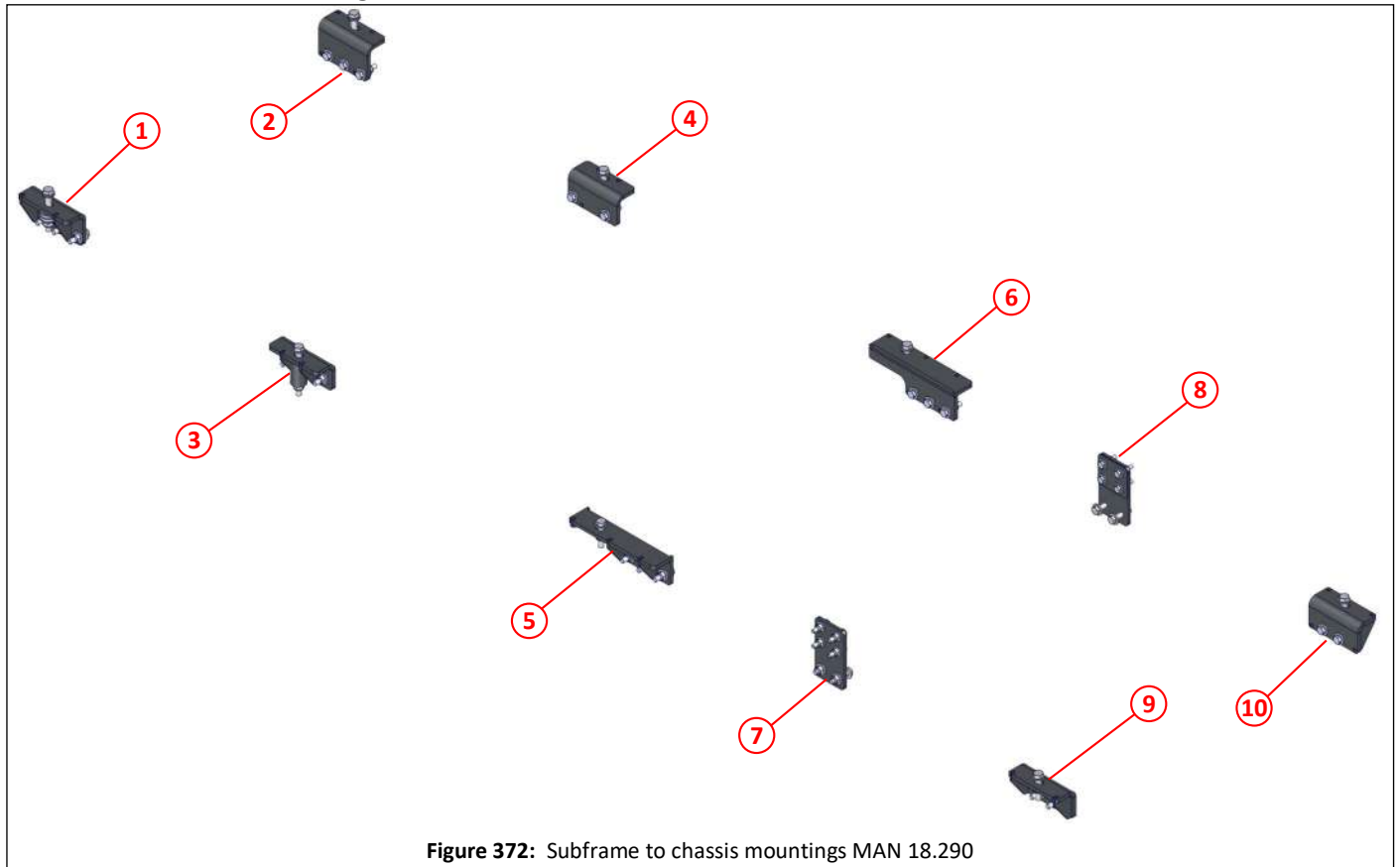

Figure 372: Subframe to chassis mountings MAN 18.290

Item	Part No	Qty	Description	
①	038629	1	Chassis mounting bracket, position 1, left hand side, MAN	410
②	038630	1	Chassis mounting bracket, position 1, right hand side, MAN	410
③	038631	1	Chassis mounting bracket, position 2, left hand side, MAN	411
④	038632	1	Chassis mounting bracket, position 2, right hand side, MAN	411
⑤	038633	1	Chassis mounting bracket, position 3, left hand side, MAN	412
⑥	038634	1	Chassis mounting bracket, position 3, right hand side, MAN	412
⑦		1	Chassis lateral support, left hand side	414
⑧		1	Chassis lateral support, right hand side	415
⑨	038635	1	Chassis mounting bracket, position 4, left hand side, MAN	413
⑩	038635	1	Chassis mounting bracket, position 4, right hand side, MAN	413

**i** Please note that fixings shown are 'standard' and your actual sweeper may have different bolts, nuts and washers etc. than what is depicted. Quantities may also vary.  
The chassis mounting brackets shown are for specific manufacturer's chassis.

Please always contact Scarab Parts Department when needing to order mounting brackets and fixings with your sweepers Works No. to ensure we match what was originally supplied.

Subframe to chassis mountings, position 1, MAN

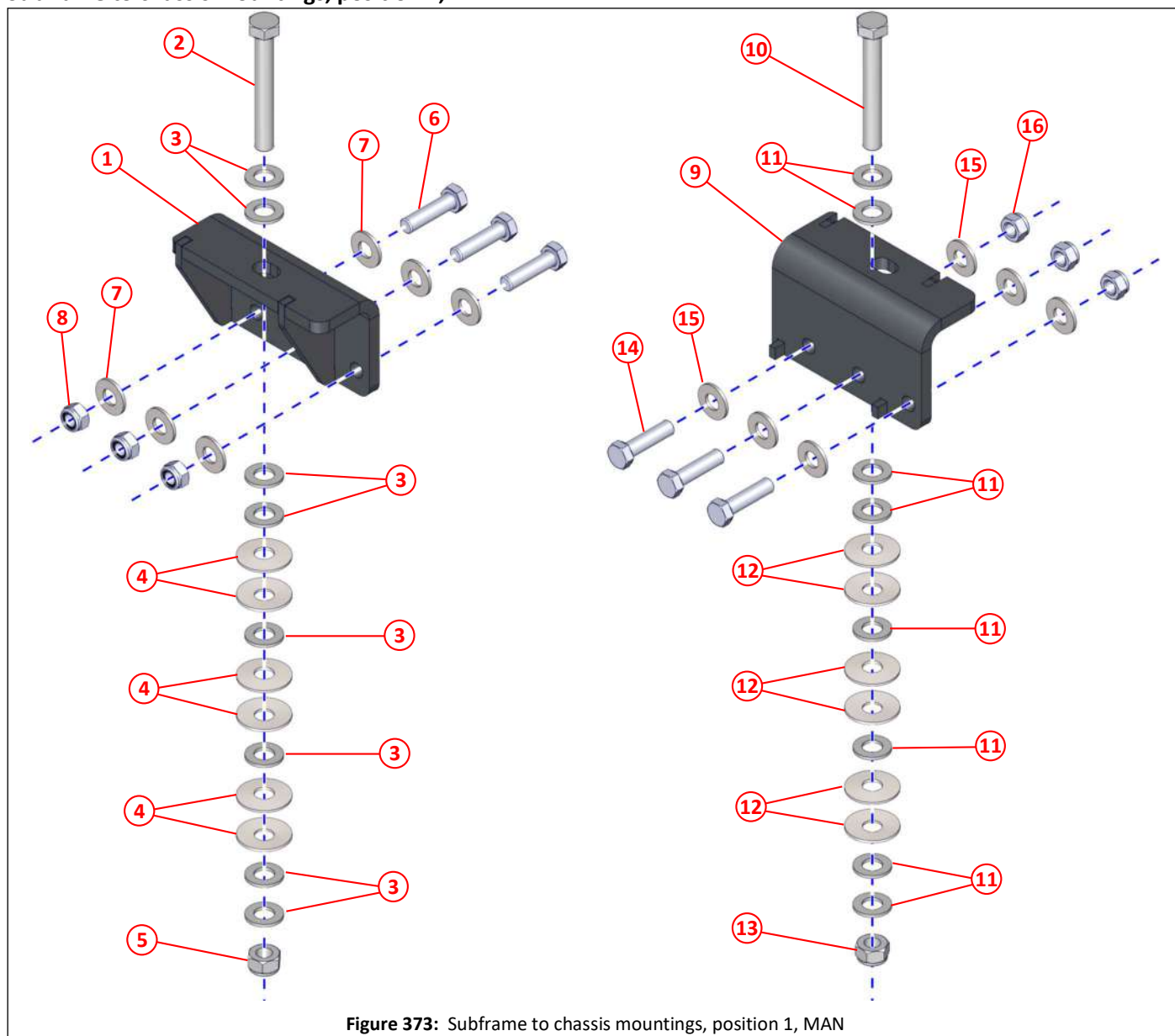

Figure 373: Subframe to chassis mountings, position 1, MAN

Item	Part No	Qty	Description	
①	038629	1	Chassis mounting bracket, position 1, left hand side, MAN	409
②	000102	1	Bolt M14 x 100	
③	000073	8	Plain washer M14	
④	036824	6	Spring, disc	
⑤	000164	1	Nyloc nut M14	
⑥	000128	3	Set bolt M12 x 45 x 1.25	
⑦	011096	6	Plain washer M12	
⑧	011086	3	Nyloc nut M12 x 1.25	
⑨	038630	1	Chassis mounting bracket, position 1, right hand side, MAN	409
⑩	000102	1	Bolt M14 x 100	
⑪	000073	8	Plain washer M14	
⑫	036824	6	Spring, disc	
⑬	000164	1	Nyloc nut M14	
⑭	000128	3	Set bolt M12 x 45 x 1.25	
⑮	011096	6	Plain washer M12	
⑯	011086	3	Nyloc nut M12 x 1.25	

## Subframe to chassis mountings, position 2, MAN

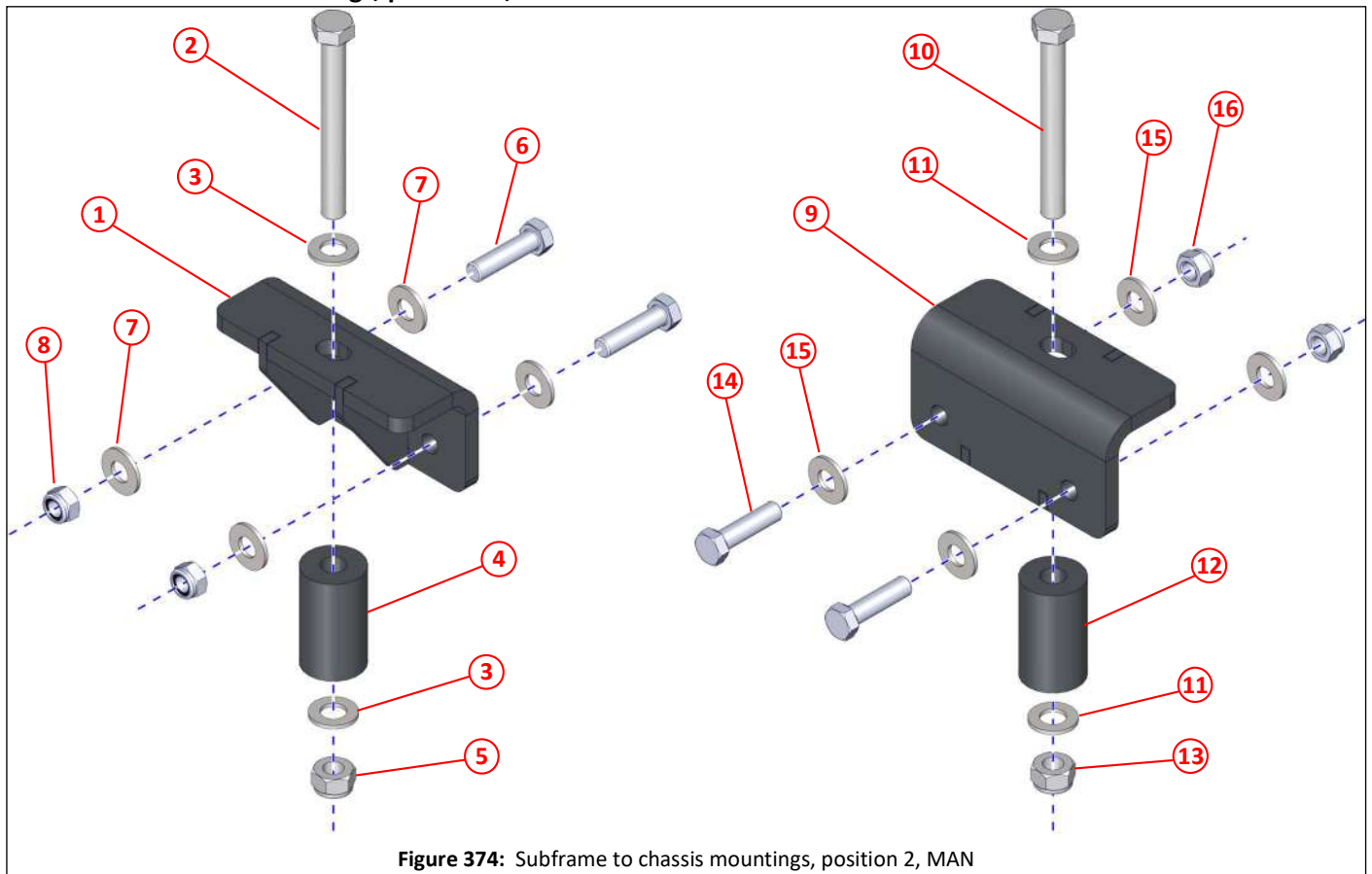

Figure 374: Subframe to chassis mountings, position 2, MAN

Item	Part No	Qty	Description	
①	038631	1	Chassis mounting bracket, position 2, left hand side, MAN	409
②	000102	1	Bolt M14 x 100	
③	000073	2	Plain washer M14	
④	034909	1	Spacer $\phi 15 \times \phi 38 \times 65$	
⑤	000164	1	Nyloc nut M14	
⑥	000128	2	Set bolt M12 x 45 x 1.25	
⑦	011096	4	Plain washer M12	
⑧	011086	2	Nyloc nut M12 x 1.25	
⑨	038632	1	Chassis mounting bracket, position 2, right hand side, MAN	409
⑩	000102	1	Bolt M14 x 100	
⑪	000073	2	Plain washer M14	
⑫	034909	1	Spacer $\phi 15 \times \phi 38 \times 65$	
⑬	000164	1	Nyloc nut M14	
⑭	000128	2	Set bolt M12 x 45 x 1.25	
⑮	011096	4	Plain washer M12	
⑯	011086	2	Nyloc nut M12 x 1.25	

Subframe to chassis mountings, position 3, MAN

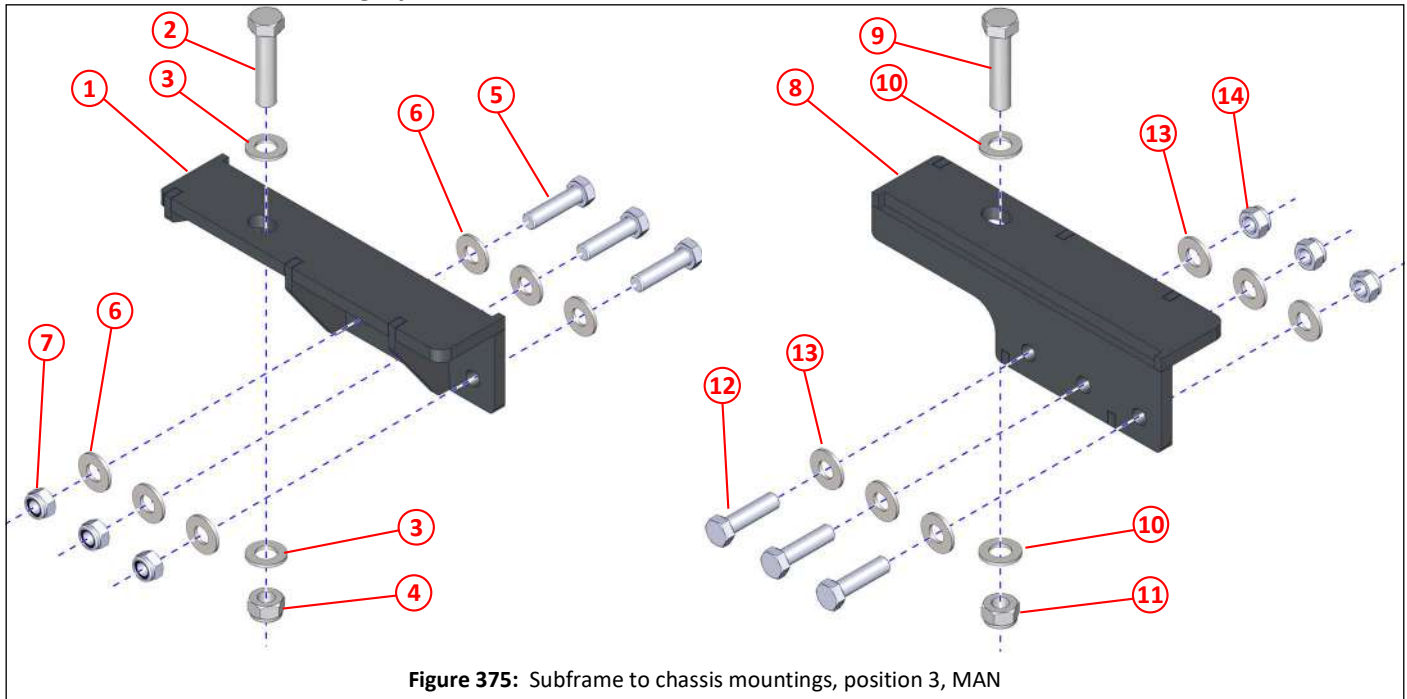

Figure 375: Subframe to chassis mountings, position 3, MAN

Item	Part No	Qty	Description	
①	038633	1	Chassis mounting bracket, position 3, left hand side, MAN	409
②	000204	1	Bolt M14 x 60	
③	000073	2	Plain washer M14	
④	000164	1	Nyloc nut M14	
⑤	000128	3	Set bolt M12 x 45 x 1.25	
⑥	011096	6	Plain washer M12	
⑦	011086	3	Nyloc nut M12 x 1.25	
⑧	038634	1	Chassis mounting bracket, position 3, right hand side, MAN	409
⑨	000204	1	Bolt M14 x 60	
⑩	000073	2	Plain washer M14	
⑪	000164	1	Nyloc nut M14	
⑫	000128	3	Set bolt M12 x 45 x 1.25	
⑬	011096	6	Plain washer M12	
⑭	011086	3	Nyloc nut M12 x 1.25	

## Subframe to chassis mountings, position 4, MAN

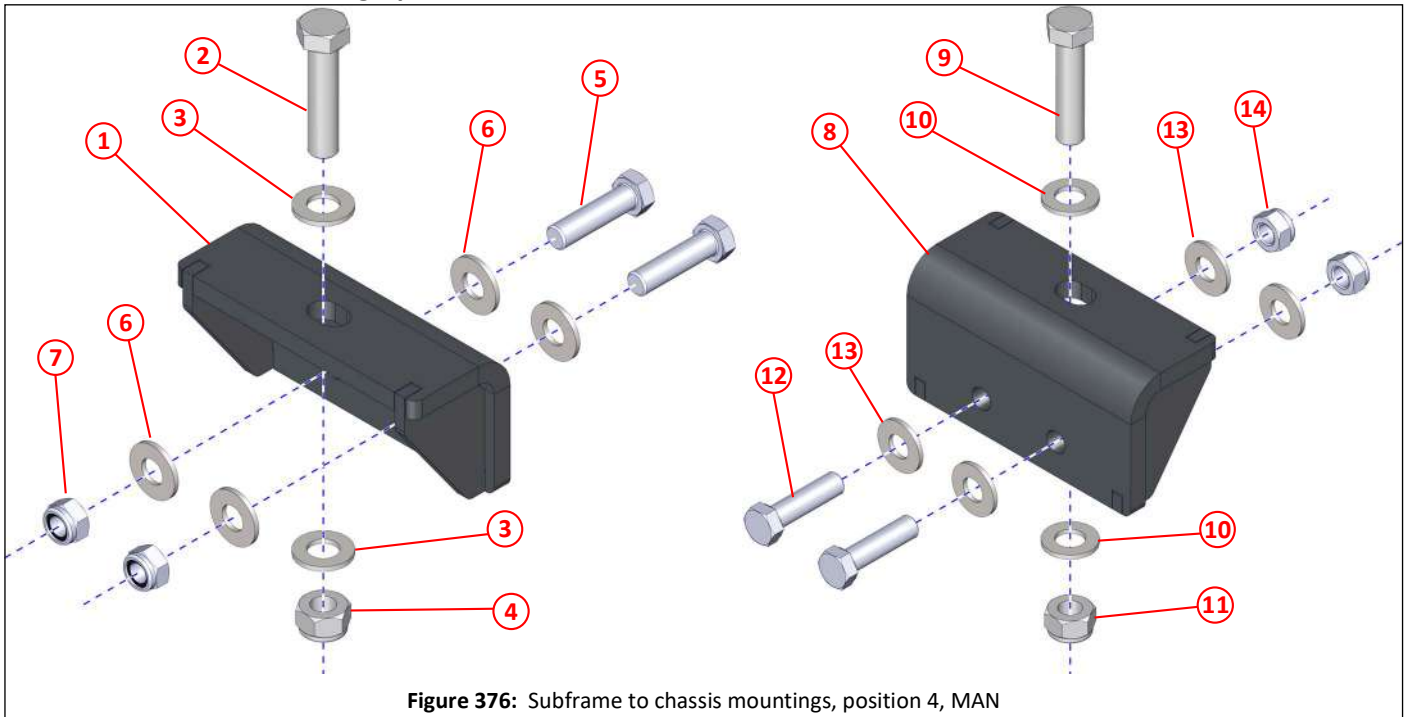

Figure 376: Subframe to chassis mountings, position 4, MAN

Item	Part No	Qty	Description	
①	038635	1	Chassis mounting bracket, position 4, left hand side, MAN	409
②	000204	1	Bolt M14 x 60	
③	000073	2	Plain washer M14	
④	000164	1	Nyloc nut M14	
⑤	000128	2	Set bolt M12 x 45 x 1.25	
⑥	011096	4	Plain washer M12	
⑦	011086	2	Nyloc nut M12 x 1.25	
⑧	038636	1	Chassis mounting bracket, position 4, right hand side, MAN	409
⑨	000204	1	Bolt M14 x 60	
⑩	000073	2	Plain washer M14	
⑪	000164	1	Nyloc nut M14	
⑫	000128	2	Set bolt M12 x 45 x 1.25	
⑬	011096	4	Plain washer M12	
⑭	011086	2	Nyloc nut M12 x 1.25	

Subframe to chassis mountings lateral support, left side, MAN

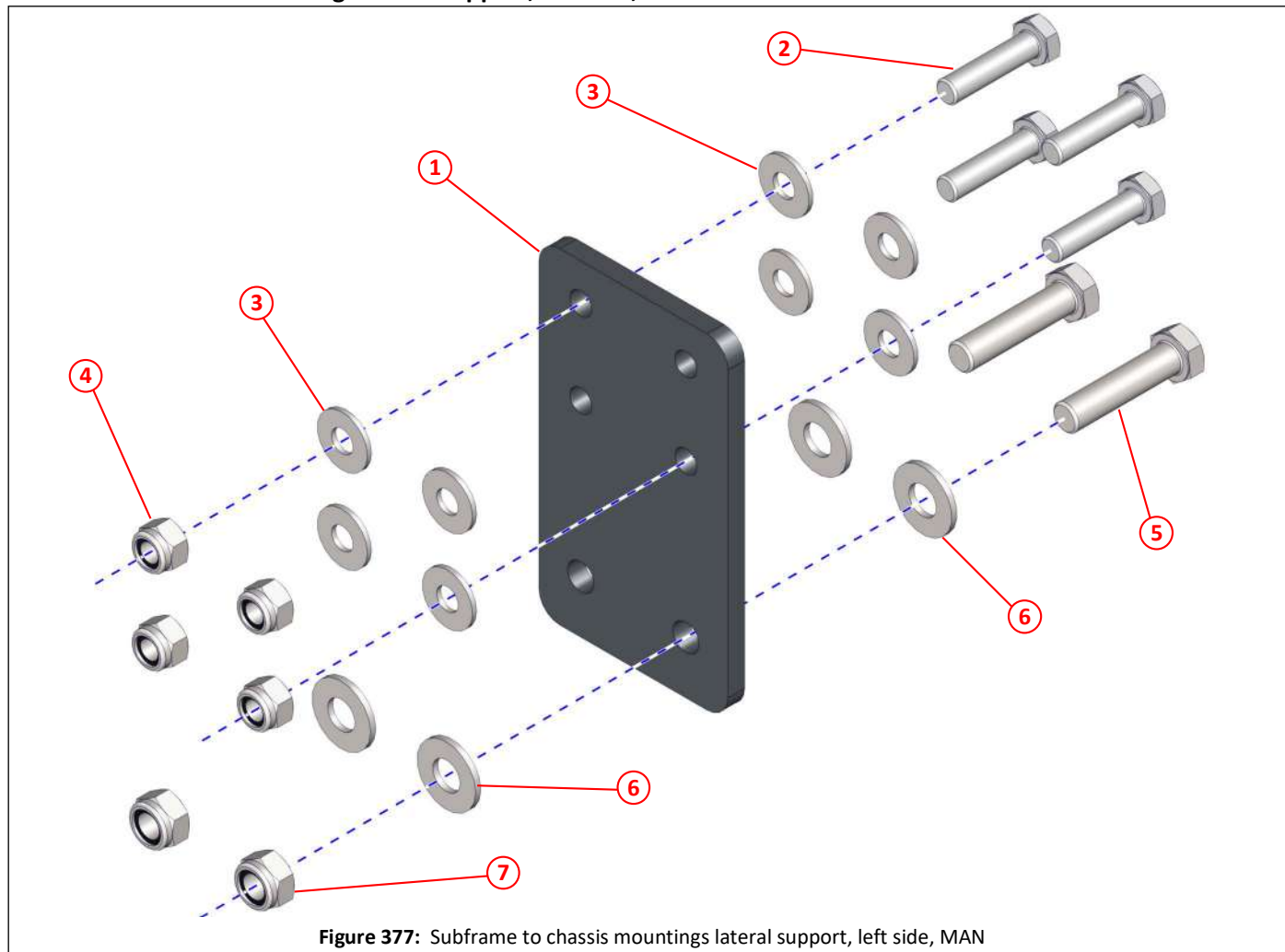

Figure 377: Subframe to chassis mountings lateral support, left side, MAN

Item	Part No	Qty	Description
①	040356	1	Bracket, lateral support, rear
②	011034	4	Set screw M10 x 40
③	011094	8	Plain washer M10
④	011075	4	Nyloc nut M10
⑤	000024	2	Bolt M12 x 50
⑥	011096	4	Plain washer M12
⑦	011077	2	Nyloc nut M12



Subframe to chassis mountings lateral support, right side, MAN

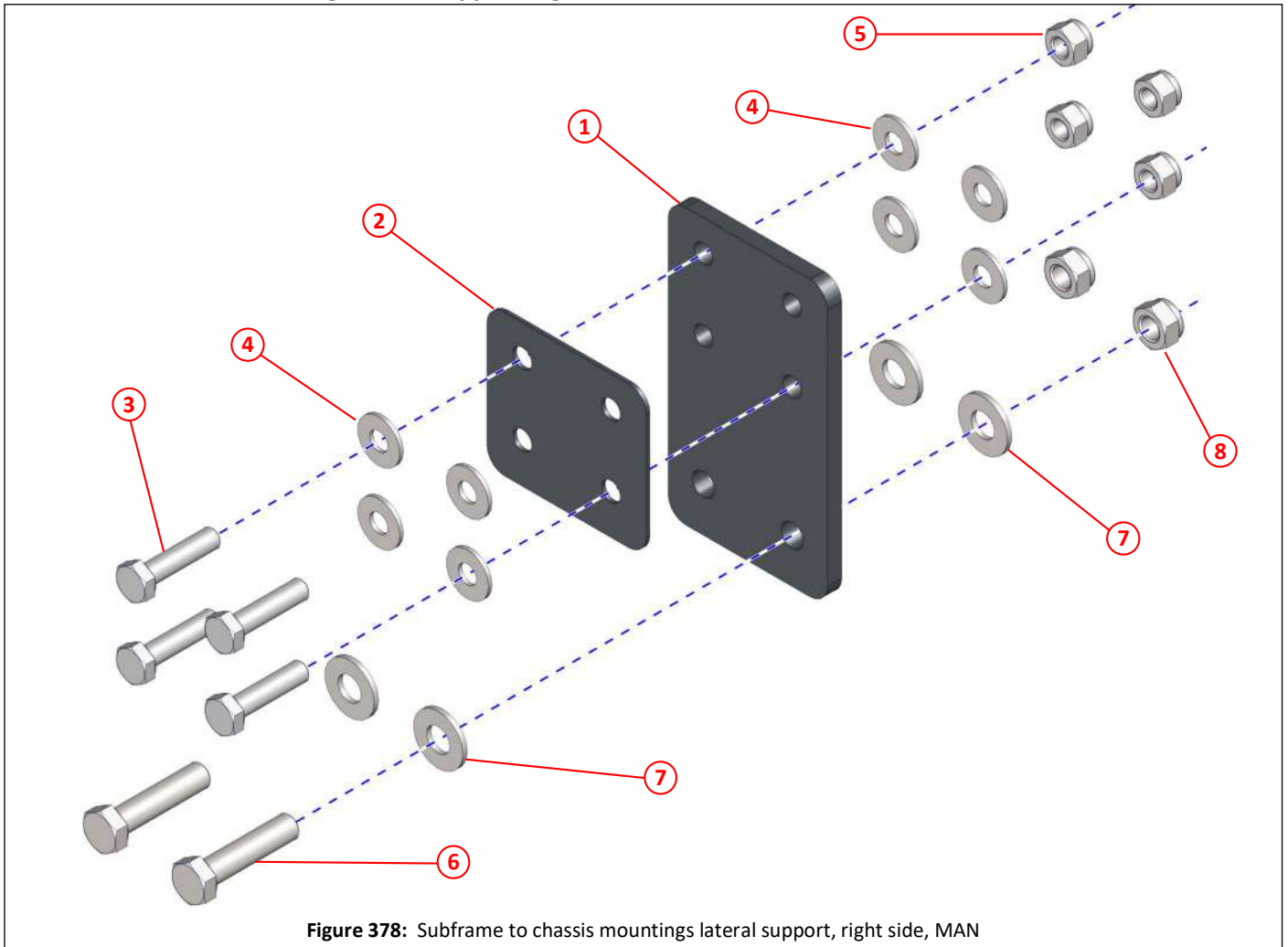

Figure 378: Subframe to chassis mountings lateral support, right side, MAN

Item	Part No	Qty	Description
①	040356	1	Bracket, lateral support, rear
②	041309	1	Packer, subframe lateral support
③	011034	4	Set screw M10 x 40
④	011094	8	Plain washer M10
⑤	011075	4	Nyloc nut M10
⑥	000024	2	Bolt M12 x 50
⑦	011096	4	Plain washer M12
⑧	011077	2	Nyloc nut M12

Subframe to chassis mountings, Freightliner M2 106

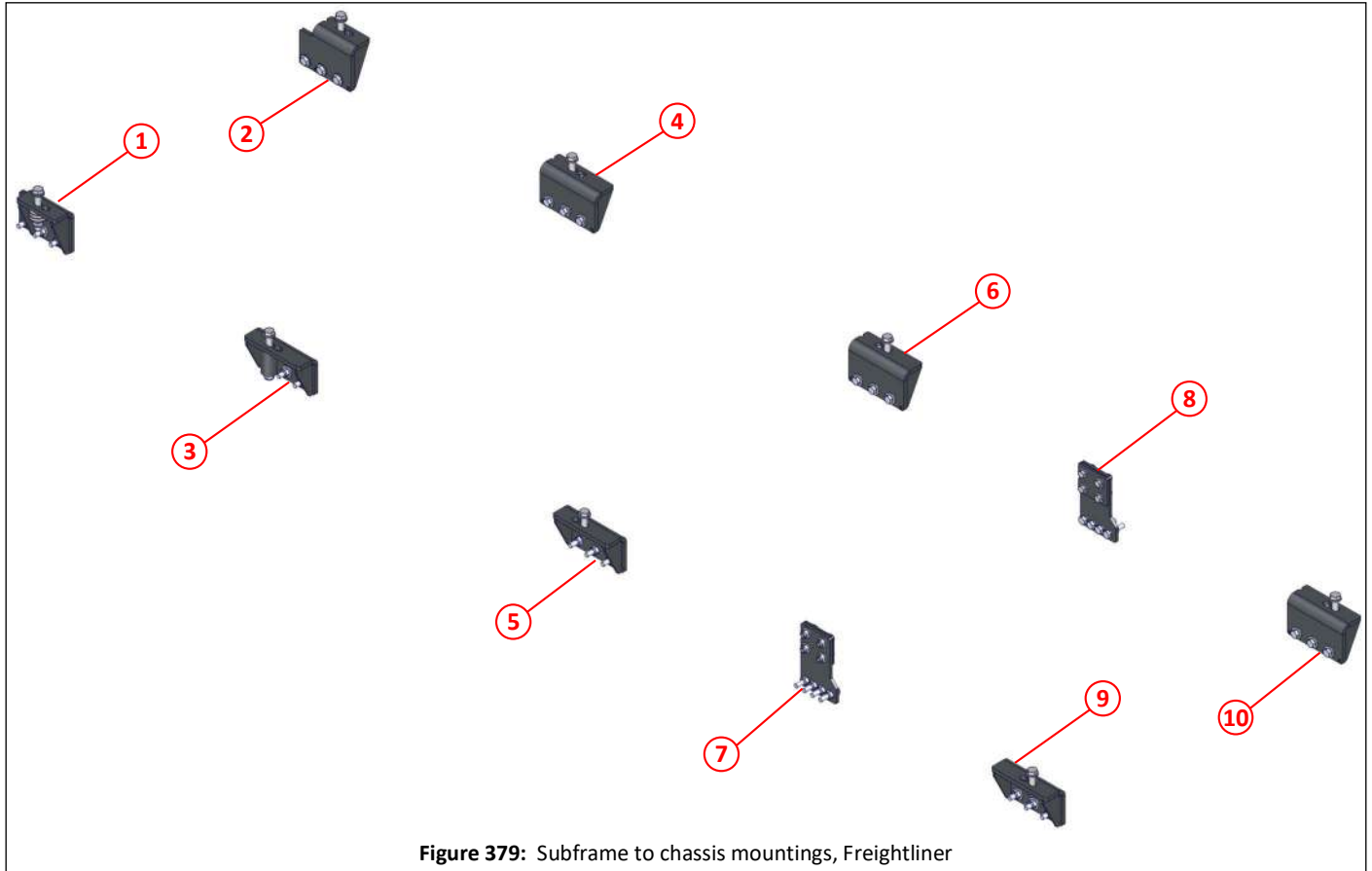

Figure 379: Subframe to chassis mountings, Freightliner

Item	Part No	Qty	Description	
①	045367	1	Chassis mounting bracket, position 1, left hand side, Freightliner	417
②	045368	1	Chassis mounting bracket, position 1, right hand side, Freightliner	417
③	045369	1	Chassis mounting bracket, position 2, left hand side, Freightliner	418
④	045370	1	Chassis mounting bracket, position 2, right hand side, Freightliner	418
⑤	045371	1	Chassis mounting bracket, position 3, left hand side, Freightliner	419
⑥	045372	1	Chassis mounting bracket, position 3, right hand side, Freightliner	419
⑦	045379	1	Chassis lateral support, left hand side, Freightliner	421
⑧	045379	1	Chassis lateral support, right hand side, Freightliner	422
⑨	045373	1	Chassis mounting bracket, position 4, left hand side, Freightliner	420
⑩	045374	1	Chassis mounting bracket, position 4, right hand side, Freightliner	420

**i** Please note that fixings shown are 'standard' and your actual sweeper may have different bolts, nuts and washers etc. than what is depicted. Quantities may also vary.  
 The chassis mounting brackets shown are for specific manufacturer's chassis.

Please always contact Scarab Parts Department when needing to order mounting brackets and fixings with your sweepers Works No. to ensure we match what was originally supplied.

Subframe to chassis mountings, position 1, Freightliner

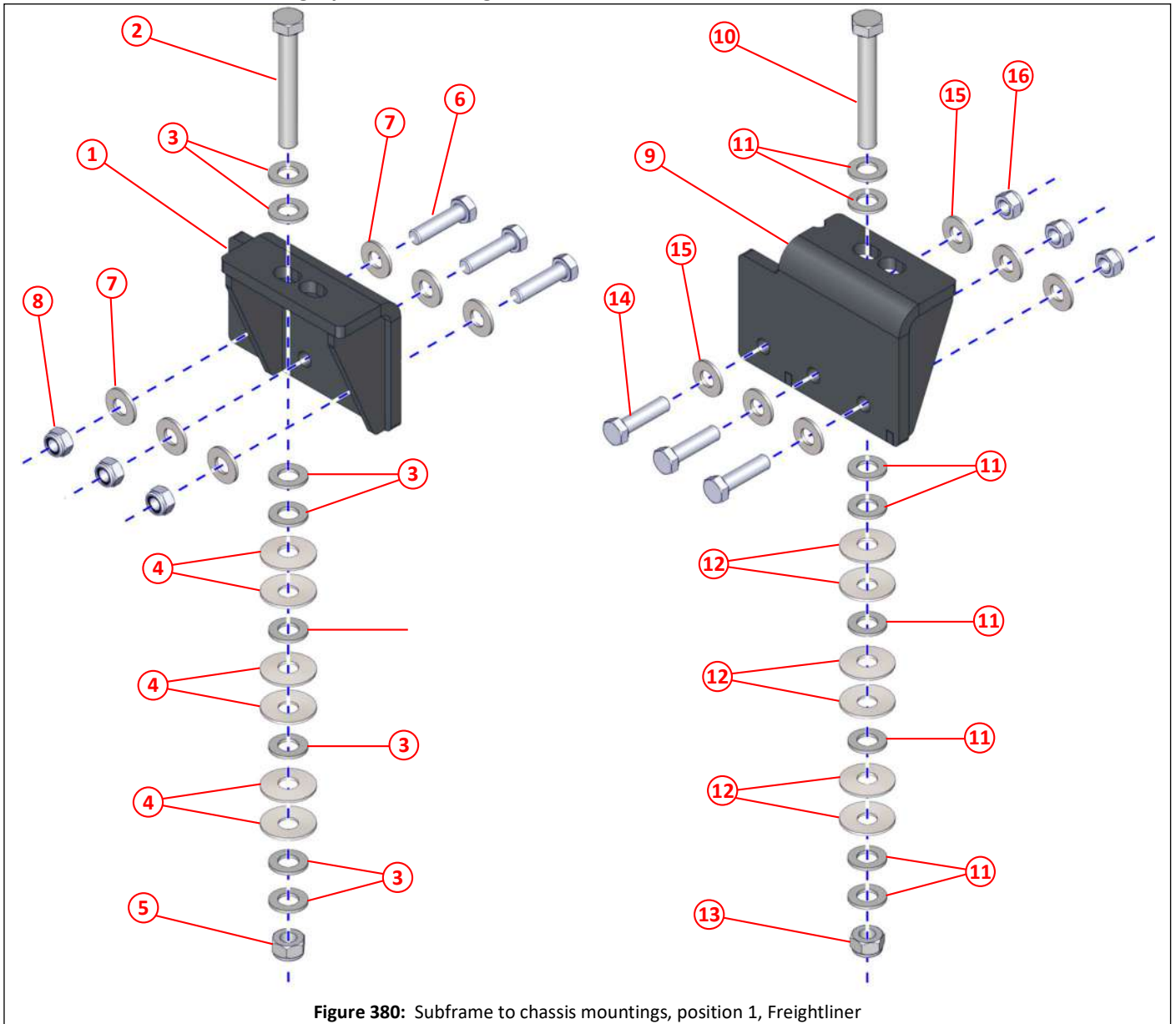

Figure 380: Subframe to chassis mountings, position 1, Freightliner

Item	Part No	Qty	Description	
①	045367	1	Chassis mounting bracket, position 1, left hand side, Freightliner	416
②	000102	1	Bolt M14 x 100	
③	000073	8	Plain washer M14	
④	036824	6	Spring, disc	
⑤	000164	1	Nyloc nut M14	
⑥	000128	3	Set bolt M12 x 45 x 1.25	
⑦	011096	6	Plain washer M12	
⑧	011086	3	Nyloc nut M12 x 1.25	
⑨	045368	1	Chassis mounting bracket, position 1, right hand side, Freightliner	416
⑩	000102	1	Bolt M14 x 100	
⑪	000073	8	Plain washer M14	
⑫	036824	6	Spring, disc	
⑬	000164	1	Nyloc nut M14	
⑭	000128	3	Set bolt M12 x 45 x 1.25	
⑮	011096	6	Plain washer M12	
⑯	011086	3	Nyloc nut M12 x 1.25	

## Subframe to chassis mountings, position 2, Freightliner

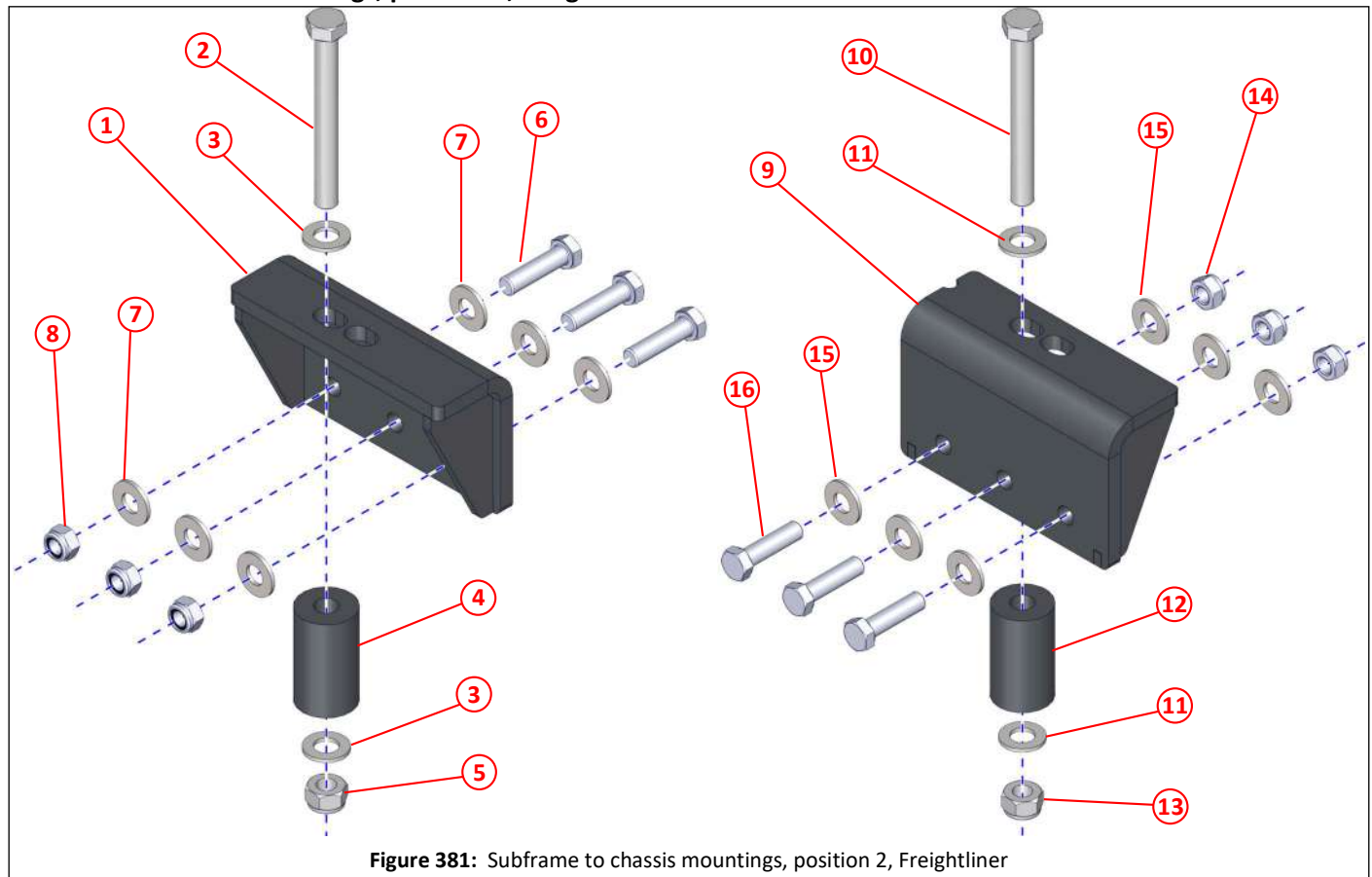

Figure 381: Subframe to chassis mountings, position 2, Freightliner

Item	Part No	Qty	Description	
①	045369	1	Chassis mounting bracket, position 2, left hand side, Freightliner	416
②	000163	1	Bolt M14 x 120	
③	000073	2	Plain washer M14	
④	034909	1	Spacer $\varnothing 15 \times \varnothing 38 \times 65$	
⑤	000164	1	Nyloc nut M14	
⑥	000128	3	Set bolt M12 x 45 x 1.25	
⑦	011096	6	Plain washer M12	
⑧	011086	3	Nyloc nut M12 x 1.25	
⑨	04530	1	Chassis mounting bracket, position 2, right hand side, Freightliner	416
⑩	000163	1	Bolt M14 x 120	
⑪	000073	2	Plain washer M14	
⑫	034909	1	Spacer $\varnothing 15 \times \varnothing 38 \times 65$	
⑬	000164	1	Nyloc nut M14	
⑭	000128	3	Set bolt M12 x 45 x 1.25	
⑮	011096	6	Plain washer M12	
⑯	011086	3	Nyloc nut M12 x 1.25	

Subframe to chassis mountings, position 3, Freightliner

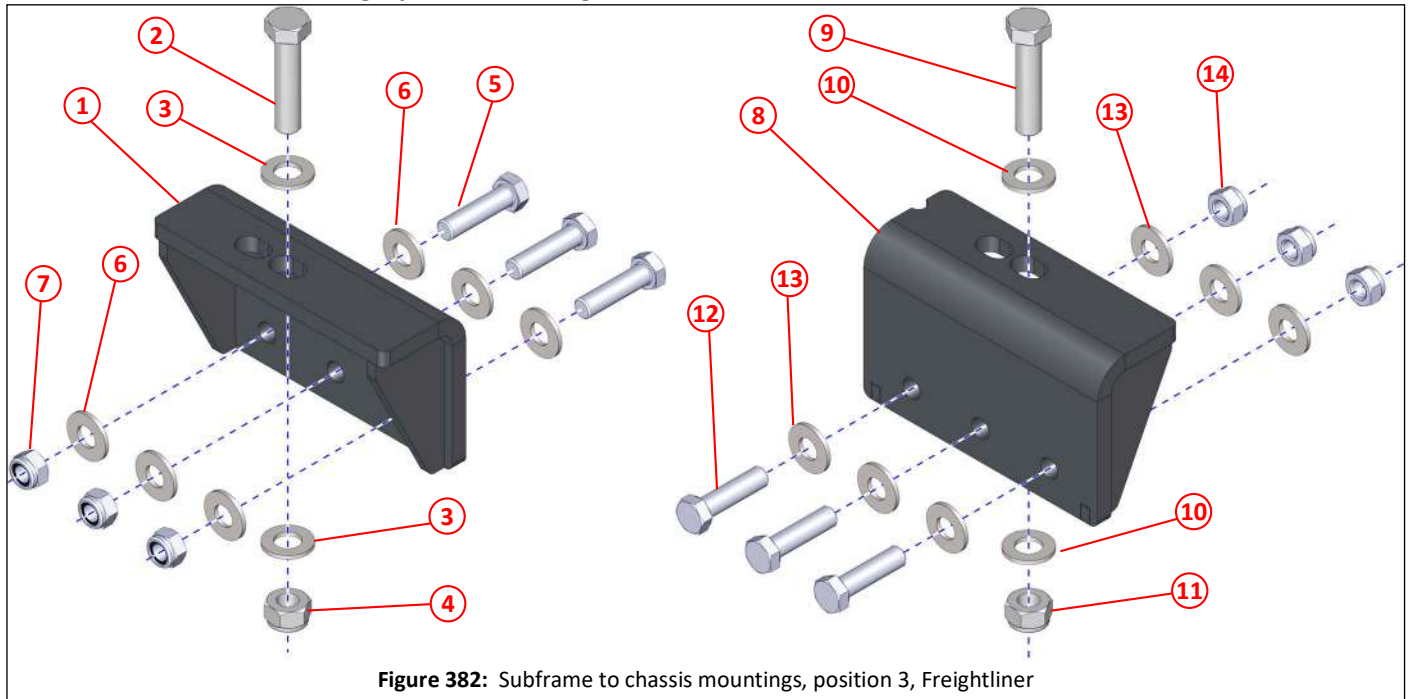

Figure 382: Subframe to chassis mountings, position 3, Freightliner

Item	Part No	Qty	Description	
①	045371	1	Chassis mounting bracket, position 3, left hand side, Freightliner	416
②	000204	1	Bolt M14 x 60	
③	000073	2	Plain washer M14	
④	000164	1	Nyloc nut M14	
⑤	000128	3	Set bolt M12 x 45 x 1.25	
⑥	011096	6	Plain washer M12	
⑦	011086	3	Nyloc nut M12 x 1.25	
⑧	045372	1	Chassis mounting bracket, position 3, right hand side, Freightliner	416
⑨	000204	1	Bolt M14 x 60	
⑩	000073	2	Plain washer M14	
⑪	000164	1	Nyloc nut M14	
⑫	000128	3	Set bolt M12 x 45 x 1.25	
⑬	011096	6	Plain washer M12	
⑭	011086	3	Nyloc nut M12 x 1.25	

## Subframe to chassis mountings, position 4, Freightliner

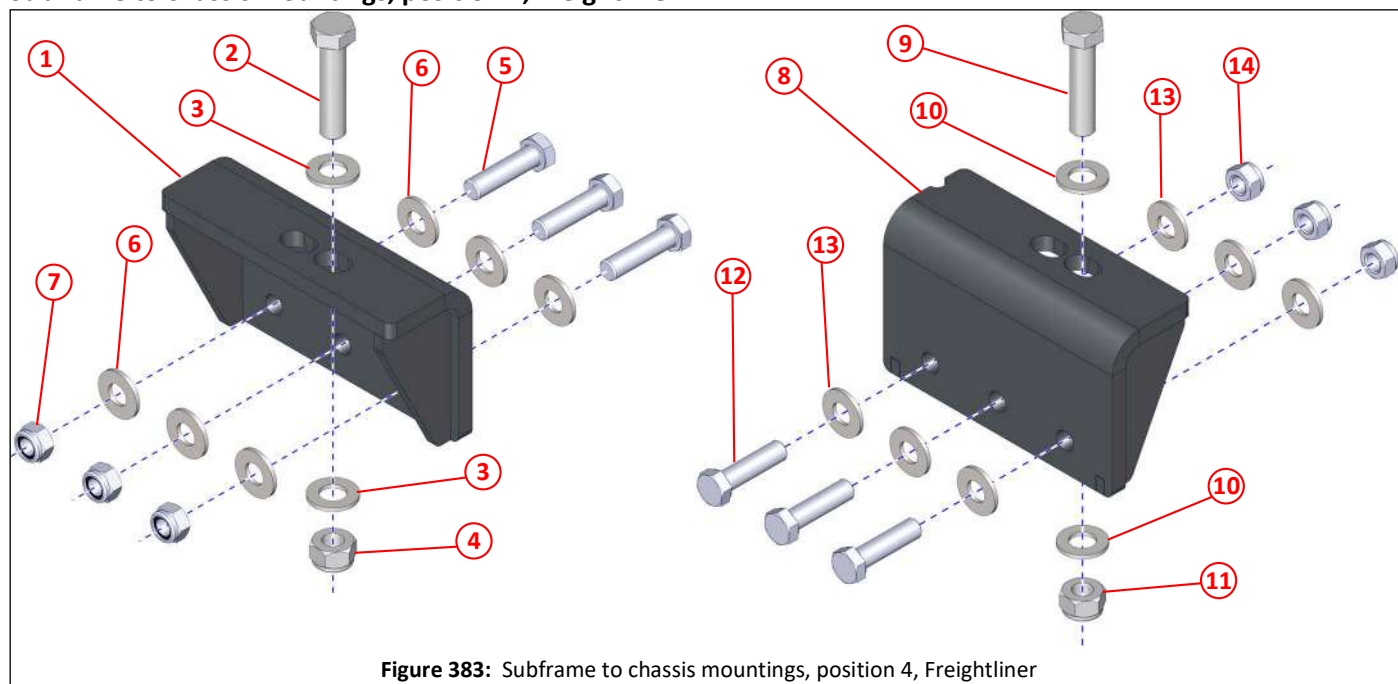

Figure 383: Subframe to chassis mountings, position 4, Freightliner

Item	Part No	Qty	Description	
①	045373	1	Chassis mounting bracket, position 4, left hand side, Freightliner	416
②	000204	1	Bolt M14 x 60	
③	000073	2	Plain washer M14	
④	000164	1	Nyloc nut M14	
⑤	000128	3	Set bolt M12 x 45 x 1.25	
⑥	011096	6	Plain washer M12	
⑦	011086	3	Nyloc nut M12 x 1.25	
⑧	045374	1	Chassis mounting bracket, position 4, right hand side, Freightliner	416
⑨	000204	1	Bolt M14 x 60	
⑩	000073	2	Plain washer M14	
⑪	000164	1	Nyloc nut M14	
⑫	000128	3	Set bolt M12 x 45 x 1.25	
⑬	011096	6	Plain washer M12	
⑭	011086	3	Nyloc nut M12 x 1.25	



Subframe to chassis mountings lateral support, left side, Freightliner

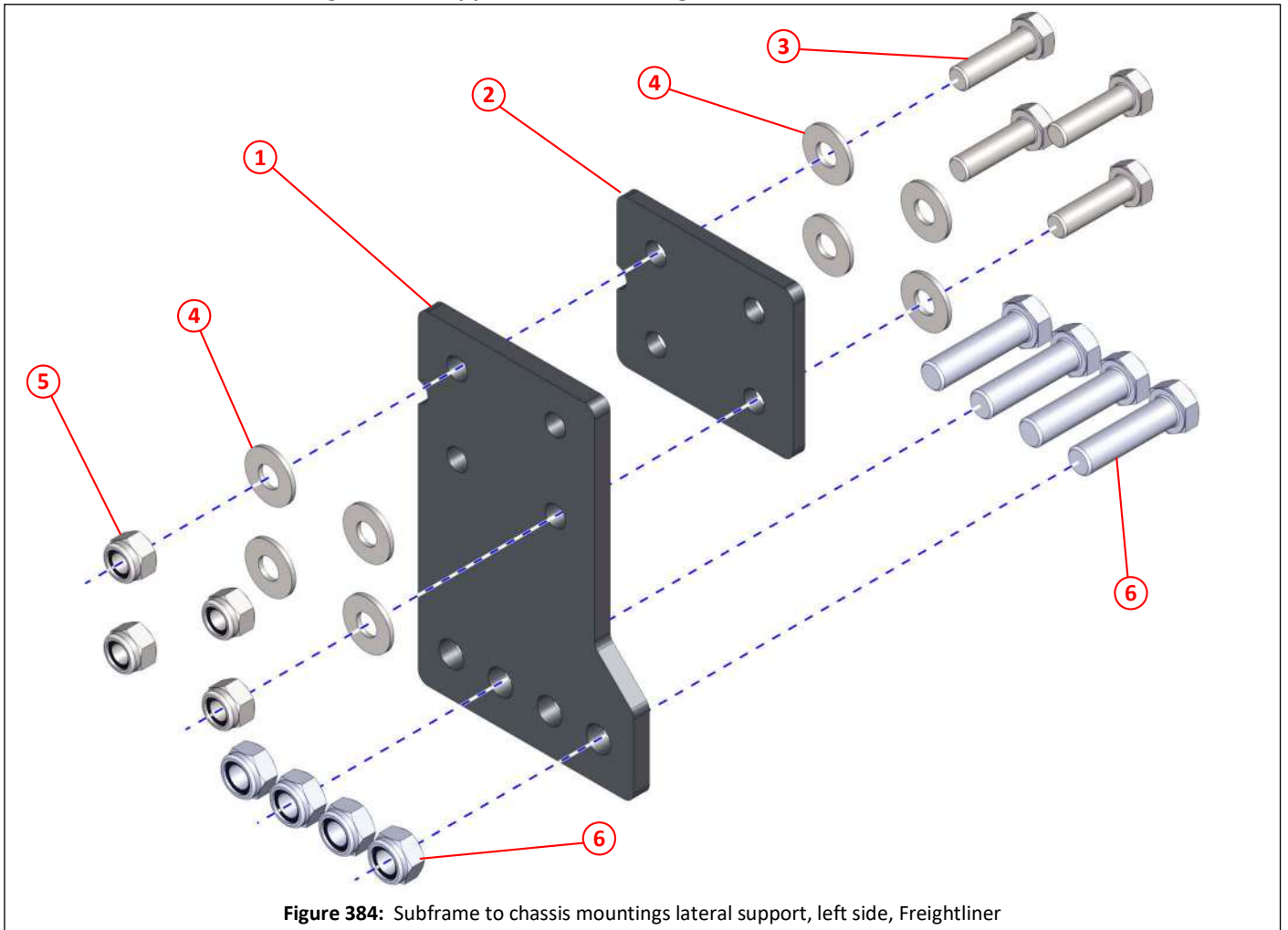

Figure 384: Subframe to chassis mountings lateral support, left side, Freightliner

Item	Part No	Qty	Description	
①	045379	1	Chassis lateral support, left hand side, Freightliner	416
②	045380	1	Packer, chassis lateral support, left hand side, Freightliner	
③	011033	4	Set screw M10 x 35	
④	011094	8	Plain washer M10	
⑤	011075	4	Nyloc nut M19	
⑥	000128	4	Set bolt M12 x 45 x 1.25	
⑦	011086	4	Nyloc nut M12	

Subframe to chassis mountings lateral support, right side, Freightliner

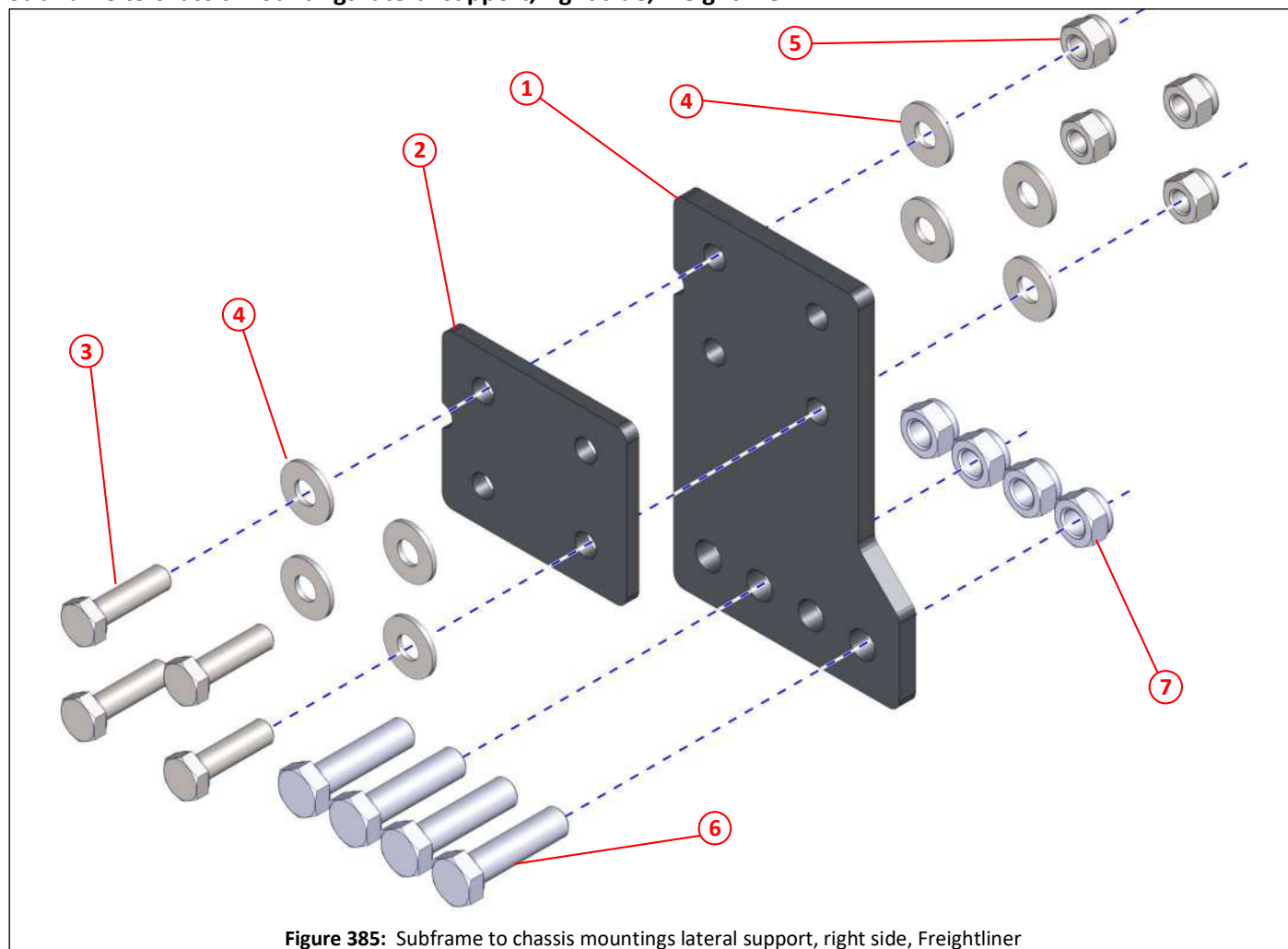

Figure 385: Subframe to chassis mountings lateral support, right side, Freightliner

Item	Part No	Qty	Description	
①	045379	1	Chassis lateral support, left hand side, Freightliner	416
②	045380	1	Packer, chassis lateral support, left hand side, Freightliner	
③	011033	4	Set screw M10 x 35	
④	011094	8	Plain washer M10	
⑤	011075	4	Nyloc nut M19	
⑥	000128	4	Set bolt M12 x 45 x 1.25	
⑦	011086	4	Nyloc nut M12	

# Engine

<i>Description</i>	<i>Page</i>
Engine .....	424
General layout, engine .....	424
Engine cradles and mounts .....	425
Engine mountings .....	426
Cooling fan, engine .....	427
Ancillary belt, alternator and engine speed sensors, engine .....	428
Starter motor, coolant temperature, rail pressure and charge air pressure/temp sensors, engine .....	429
Oil pressure sensor, engine .....	430
Fuel injectors and glow plugs, engine .....	431
DUETZ TCD 3.6 L4 engine .....	432
Fuel pump and filters, engine .....	433
Exhaust stack, engine .....	434
Air intake stack, engine .....	435
Expansion tank, engine .....	436
Combined intercooler/radiator/hydraulic oil cooler, engine .....	437
Other components, engine .....	438
Centaflex coupling and fan pump housing plate, engine .....	439

## General layout, engine

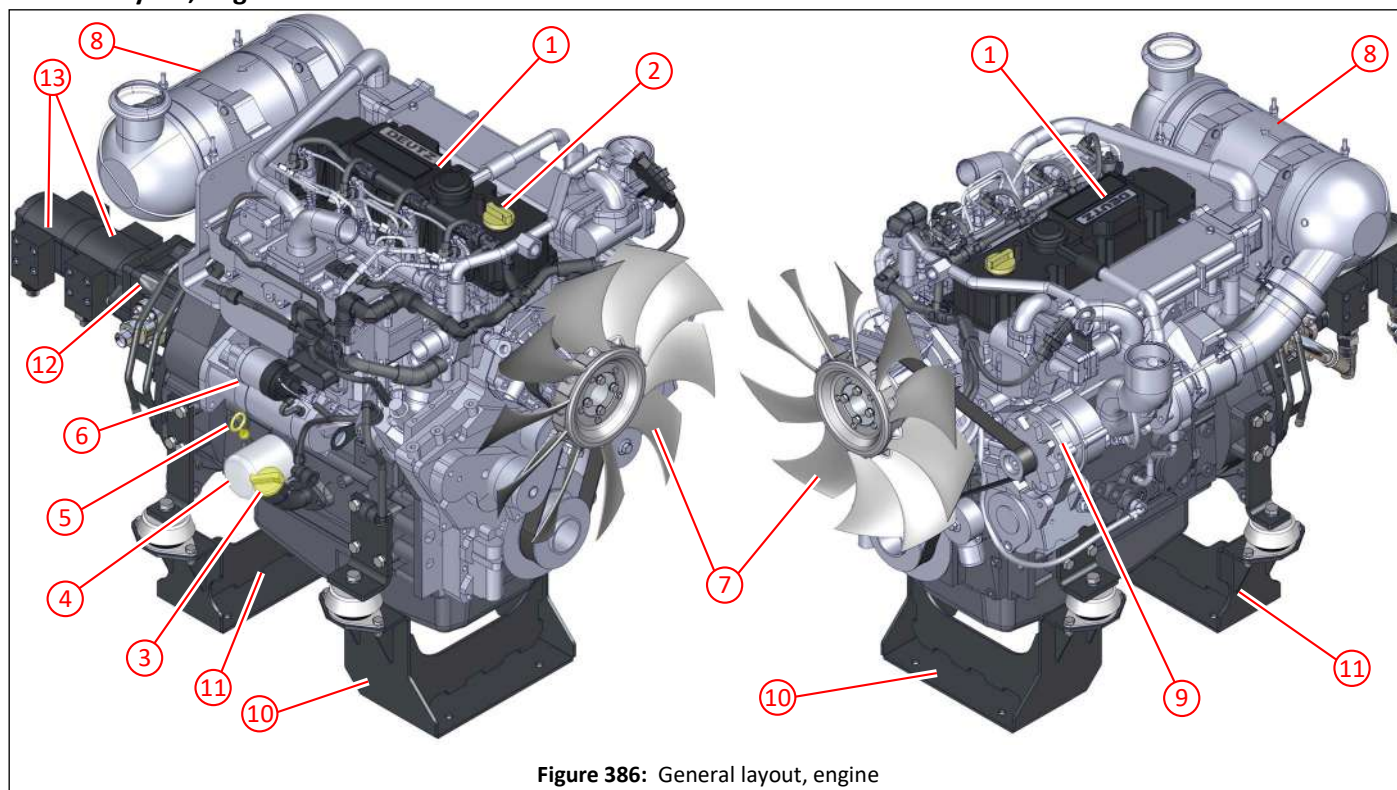

Figure 386: General layout, engine

Item	Part No	Qty	Description	
①		1	DEUTZ TCD 3.6 L4 engine	432
②	043781	1	Filler cap, engine oil, rocker box	
③	043781	1	Filler cap, engine oil, engine side	
④	042232	1	Filter, engine oil	
⑤	043222	1	Dipstick	438
⑥	043795	1	Starter motor, 24v	429
⑥	044516	1	Starter motor, 12v	429
⑦		1	Cooling fan assembly	427
⑧	TBA	1	Diesel particle filter (DPF)	
⑨	043816	1	Alternator, 28v 55A, 24v	428
⑨	044517	1	Alternator, 14v 95A, 12v	428
⑩	042809	1	Engine cradle, front	358
⑪	042810	1	Engine cradle, rear	357
⑫		1	Fan pump	252,253
⑬		2	Gear pumps	252,254

**i** Please be aware that this page and the following pages have both 24v and 12v components. Please ensure you select the correct voltage part for your vehicle.

Engine cradles and mounts

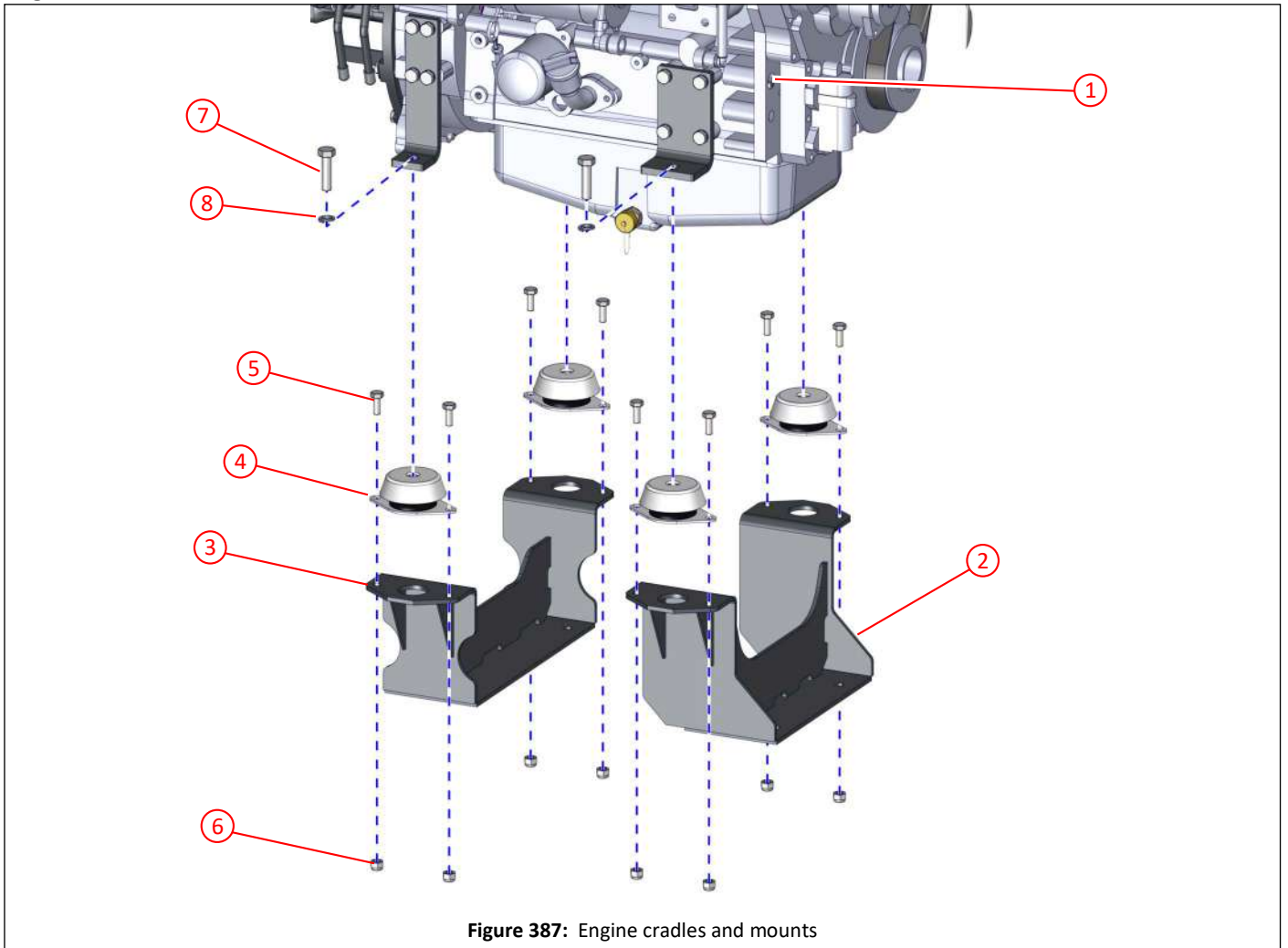

Figure 387: Engine cradles and mounts

Item	Part No	Qty	Description	
①		1	DEUTZ TCD 3.6 L4 engine	432
②	042809	1	Engine cradle, front	358
③	042810	1	Engine cradle, rear	357
④	030724	4	Engine mount	426
⑤	011031	8	Set screw M10 x 25	
⑥	011075	8	Nyloc nut M10	
⑦	011403	4	Bolt M14 x 50	
⑧	011106	4	Spring washer M14	



Engine mountings

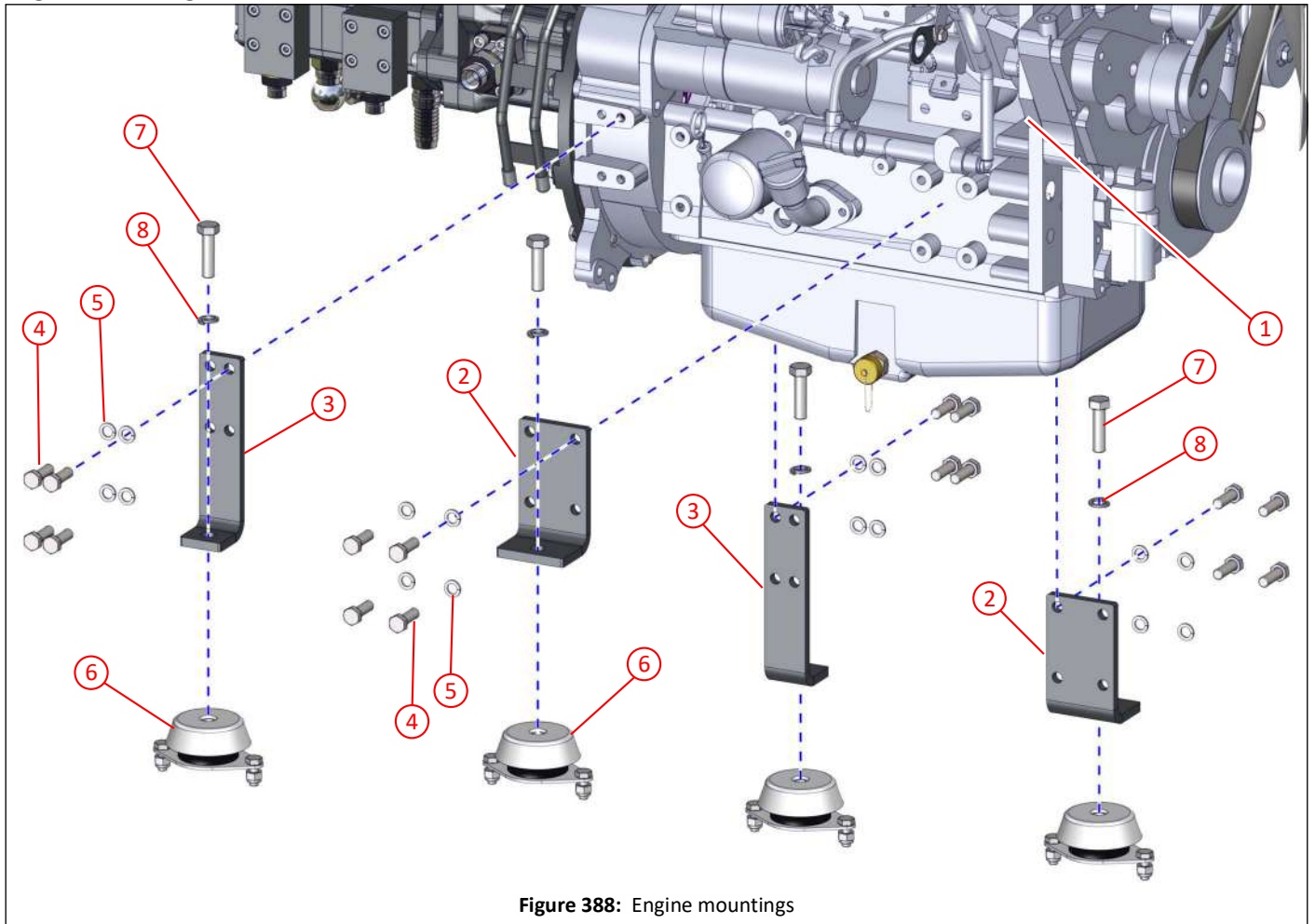

Figure 388: Engine mountings

Item	Part No	Qty	Description	
①		1	DEUTZ TCD 3.6 L4 engine	432
②	042808	2	Engine mount, front	
③	042811	2	Engine mount, rear	
④	011053	16	Set screw M12 x 35	
⑤	011097	16	Spring washer M12	
⑥	030724	4	Engine mount	425
⑦	011403	4	Bolt M14 x 50	
⑧	011106	4	Spring washer M14	



Cooling fan, engine

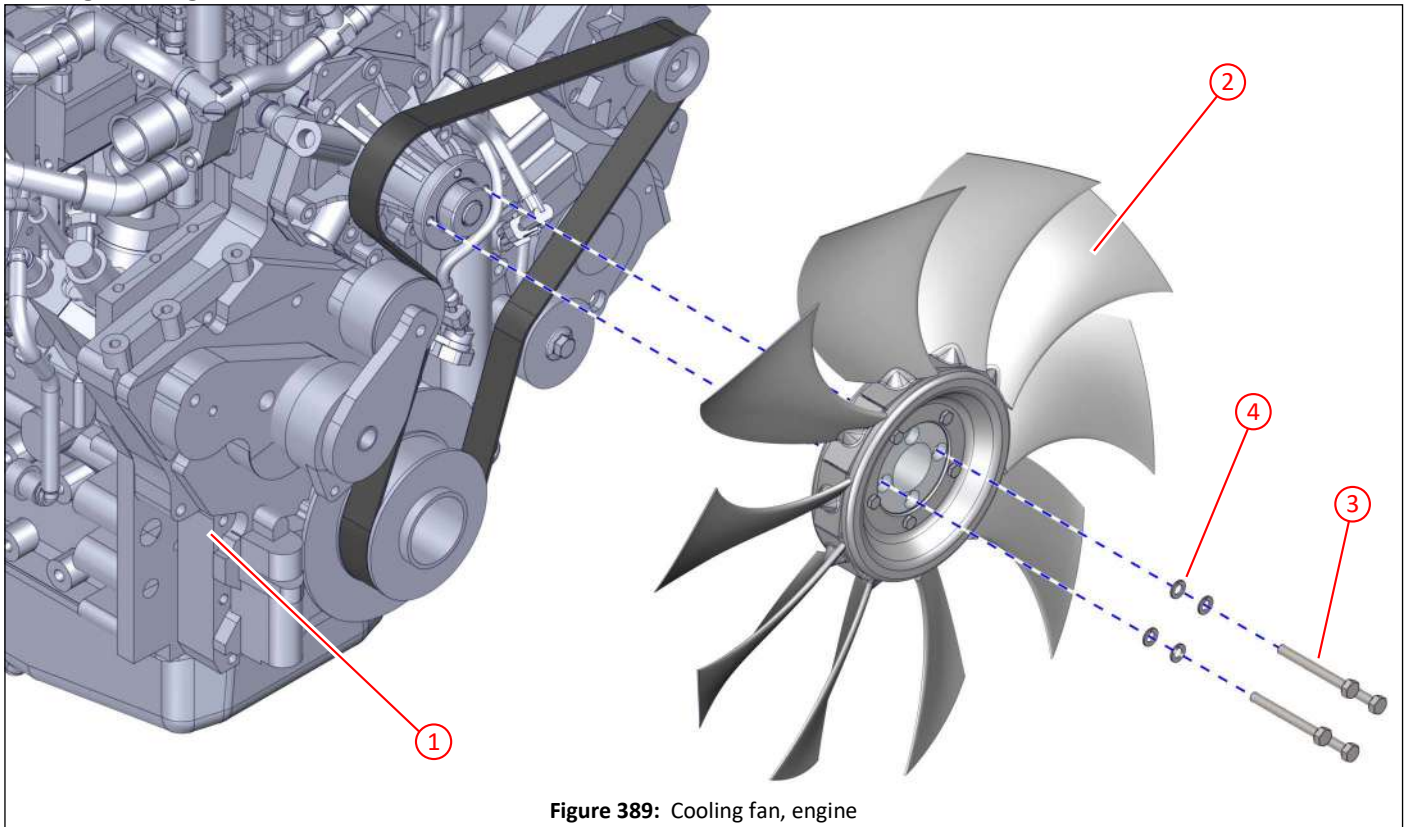

Figure 389: Cooling fan, engine

Item	Part No	Qty	Description	
①		1	DEUTZ TCD 3.6 L4 engine	432
②	043161	1	Fan and hub	
③	011018	4	Bolt M8 x 70	
④	011093	4	Spring washer M8	

Ancillary belt, alternator and engine speed sensors, engine

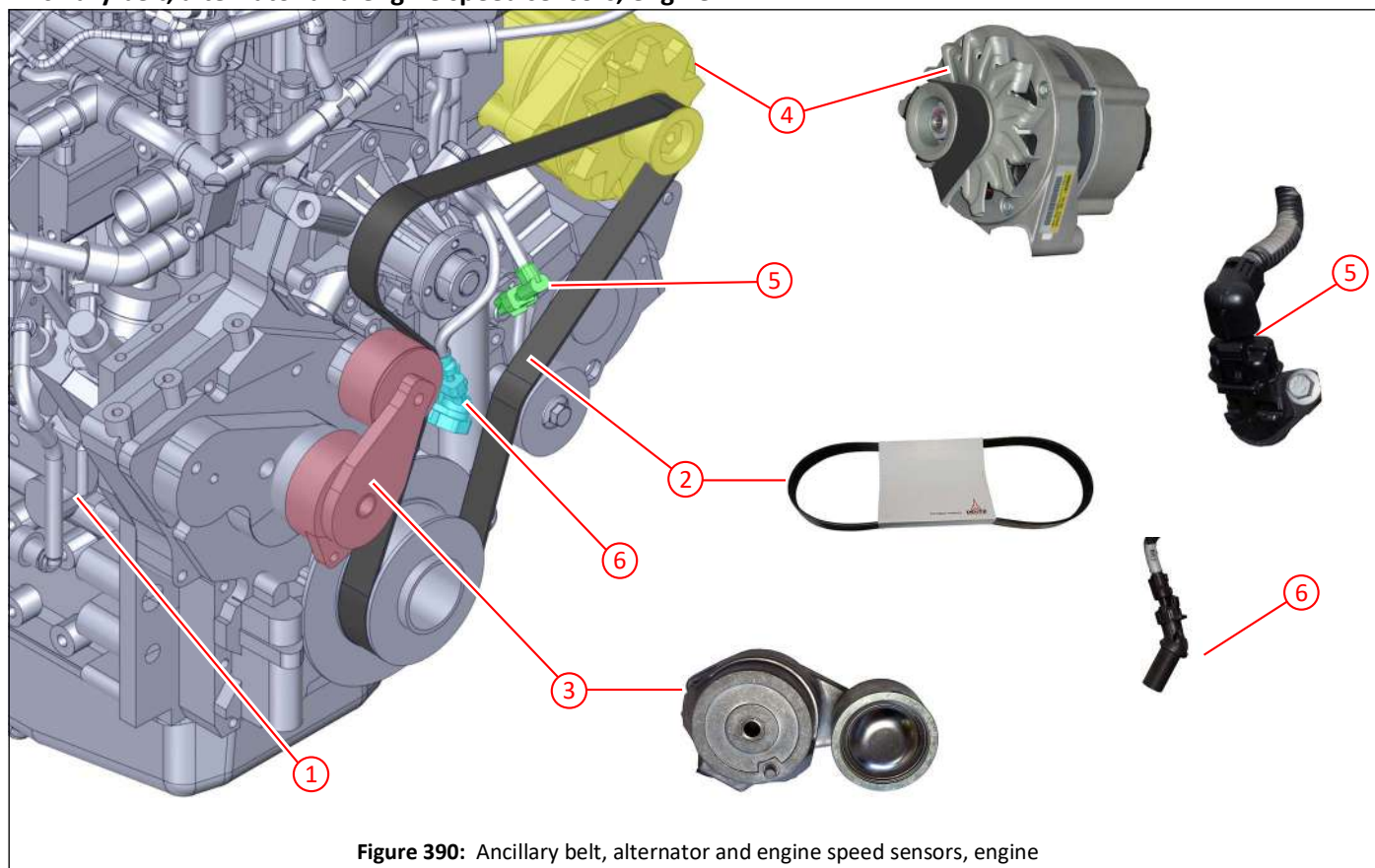

Figure 390: Ancillary belt, alternator and engine speed sensors, engine

Item	Part No	Qty	Description	
①		1	DEUTZ TCD 3.6 L4 engine	432
②	043789	1	V-ribbed belt	
③	043815	1	Tensioner, v-ribbed belt	
④	043816	1	Alternator, 28v 55A, 24v	430
④	044517	1	Alternator, 14v 95A, 12v	430
⑤	043797	1	Speed sensor, camshaft	
⑥	043797	1	Speed sensor, crankshaft	

Starter motor, coolant temperature, rail pressure and charge air pressure/temp sensors, engine

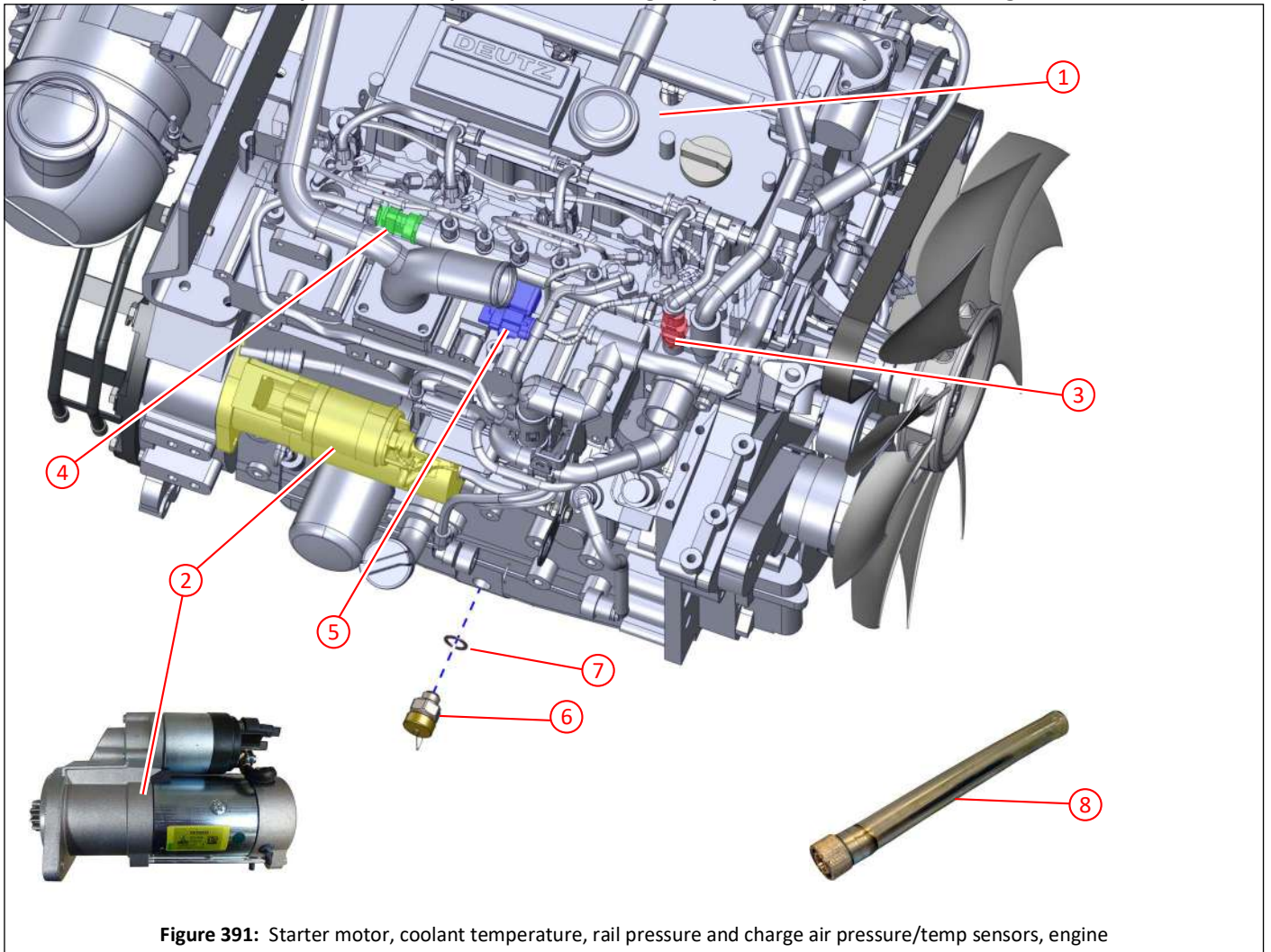

Figure 391: Starter motor, coolant temperature, rail pressure and charge air pressure/temp sensors, engine

Item	Part No	Qty	Description	
①		1	DEUTZ TCD 3.6 L4 engine	432
②	043795	1	Starter motor, 24v	
②	044516	1	Starter motor, 12v	
③	043814	1	Coolant temperature sender	
④	043785	1	Pressure sensor, rail	
⑤	043798	1	Charge air pressure transmitter and charge air temperature transmitter	
⑥	043568	1	Drain valve, sump	
⑦	043567	1	Copper sealing ring	
⑧	043569	1	Connector, drain hose, sump drain	



Oil pressure sensor, engine

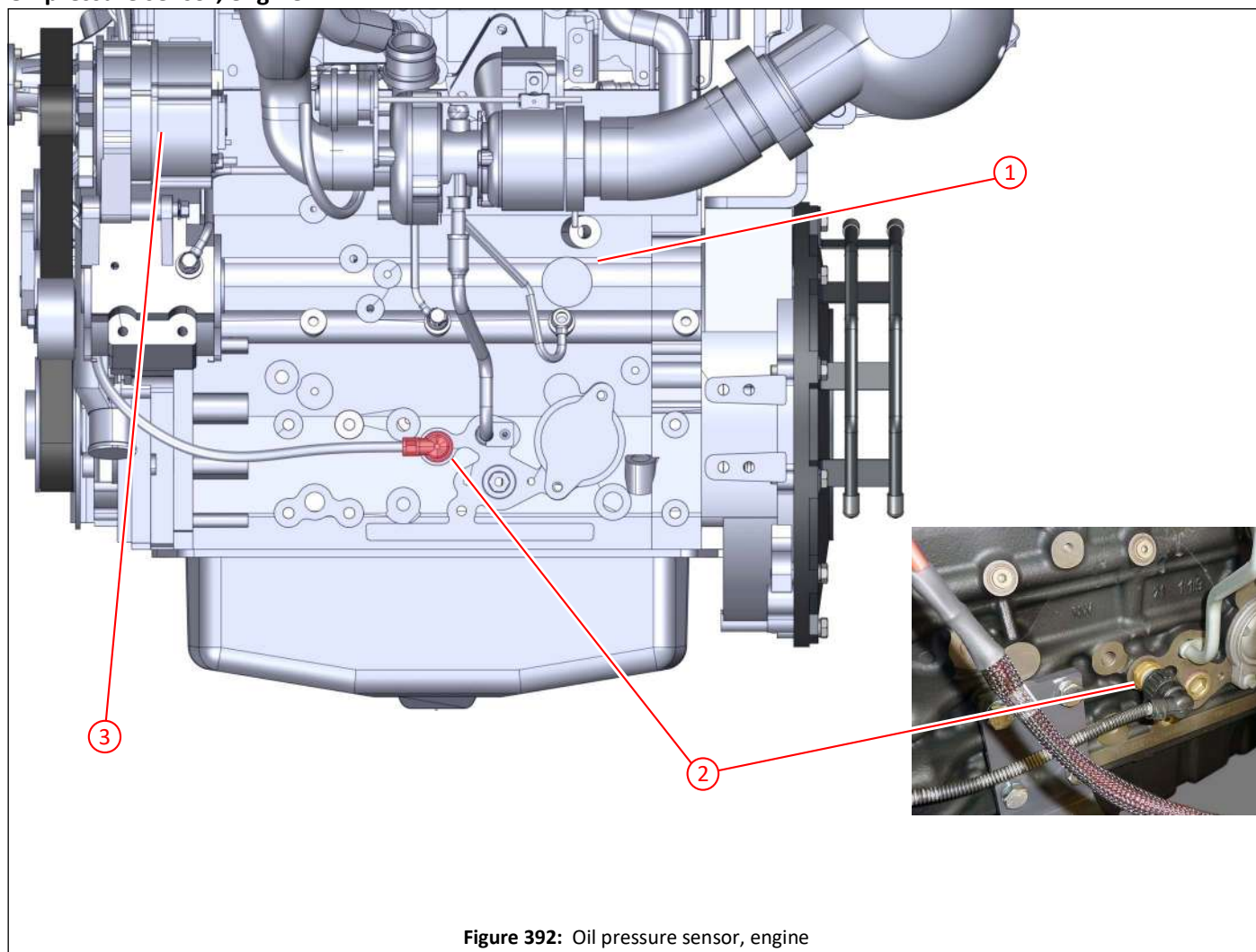

Figure 392: Oil pressure sensor, engine

Item	Part No	Qty	Description	
①		1	DEUTZ TCD 3.6 L4 engine	432
②	043785	1	Pressure sensor, oil	
③	043816	1	Alternator, 28v 55A, 24v	428
③	044517	1	Alternator, 14v 95A, 12v	428

Fuel injectors and glow plugs, engine

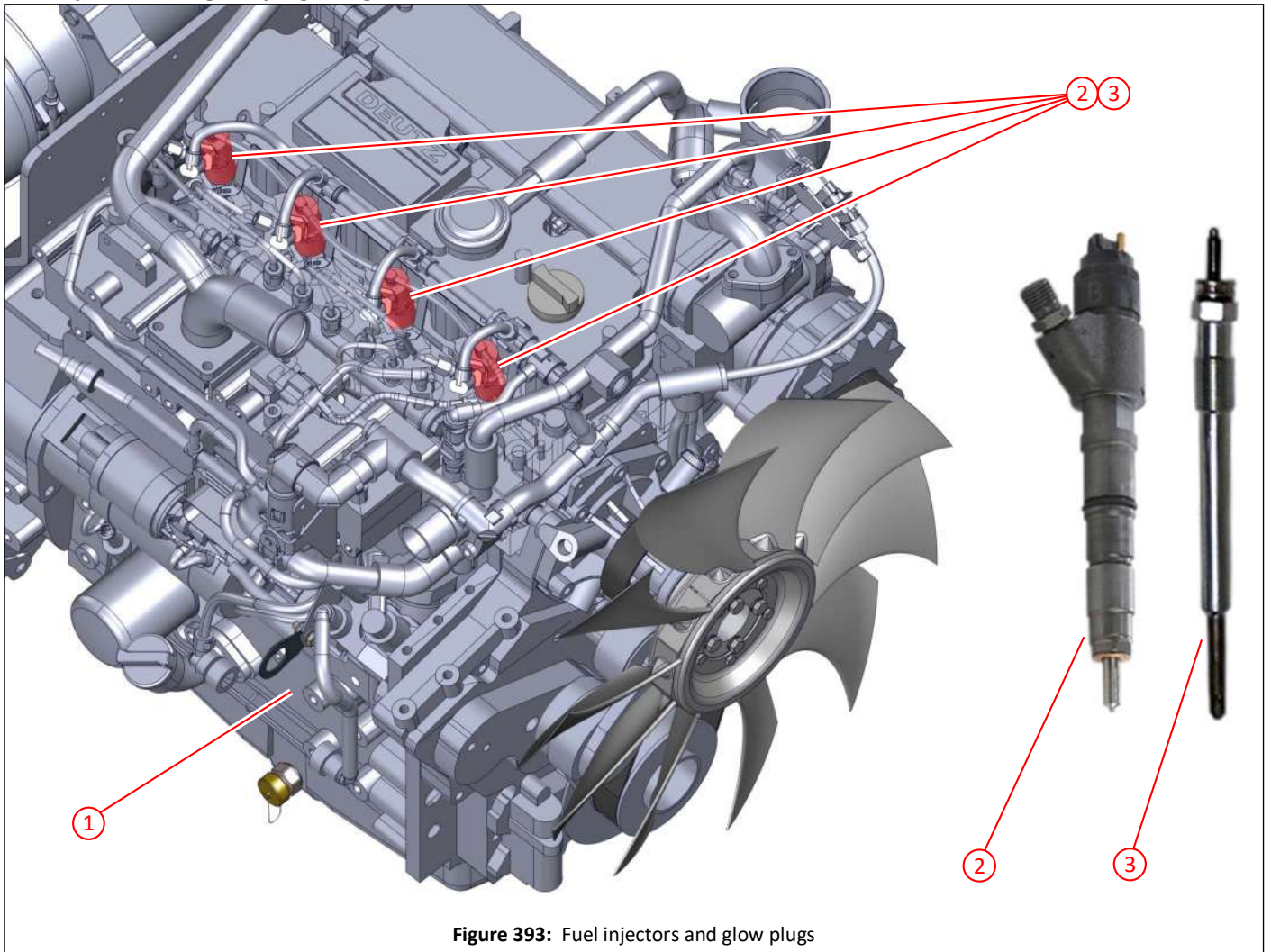

Figure 393: Fuel injectors and glow plugs

Item	Part No	Qty	Description	
①		1	DEUTZ TCD 3.6 L4 engine	432
②	043793	4	Fuel injector	
③	043799	4	Glow plug, 24v	
③	043820	4	Glow plug, 12v	

## DEUTZ TCD 3.6 L4 engine

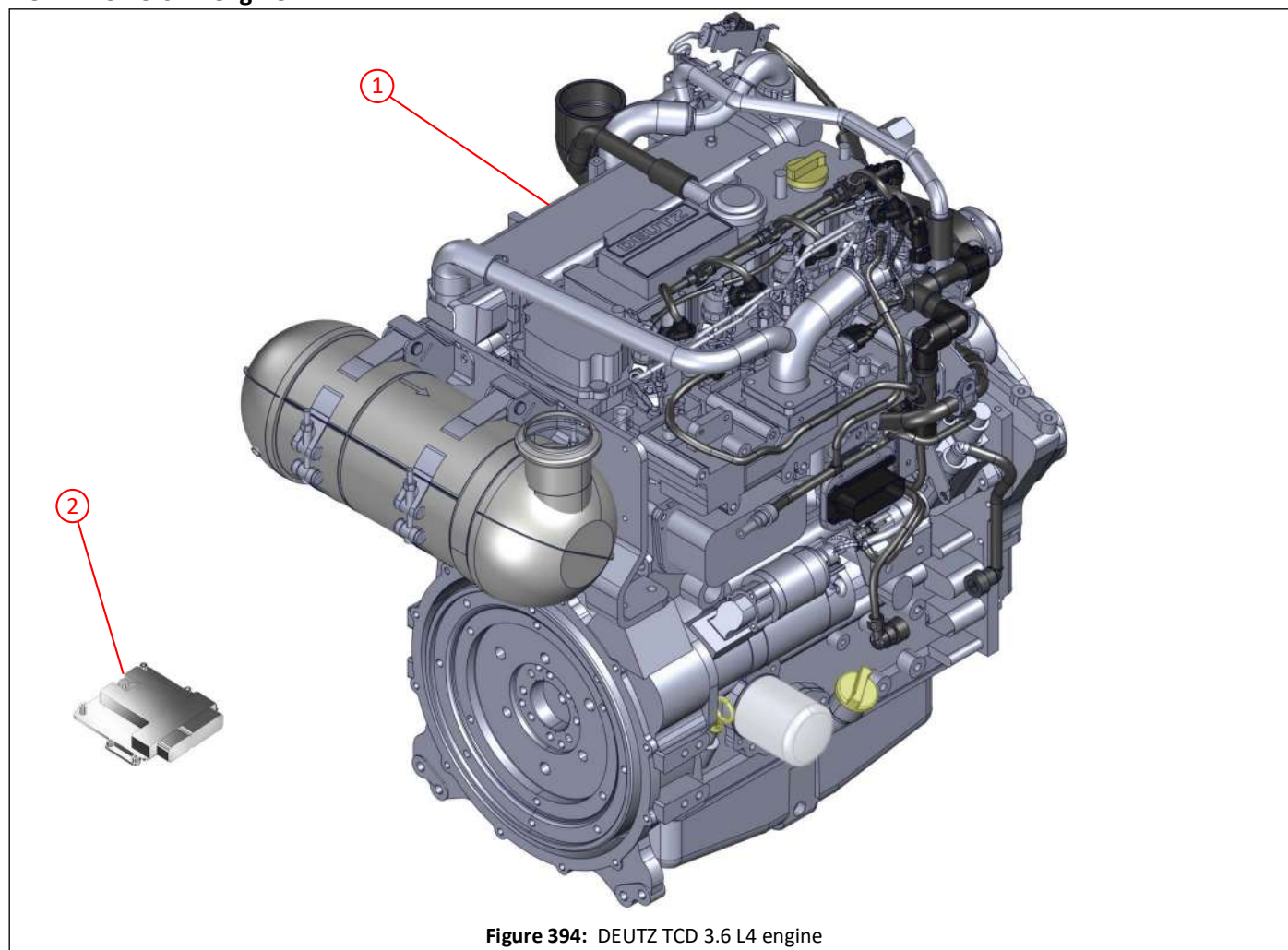

Figure 394: DEUTZ TCD 3.6 L4 engine

Item	Part No	Qty	Description
①	042483	1	DEUTZ TCD 3.6 L4 engine, 24v
①	044512	1	DEUTZ TCD 3.6 L4 engine, 12v
②	044500 *	1	ECU, 12v and 24v
NI	043344	1	Loom, DEUTZ engine

\*. The ECU will need to be matched to the serial number of the DEUTZ auxiliary engine of your vehicle.



Fuel pump and filters, engine

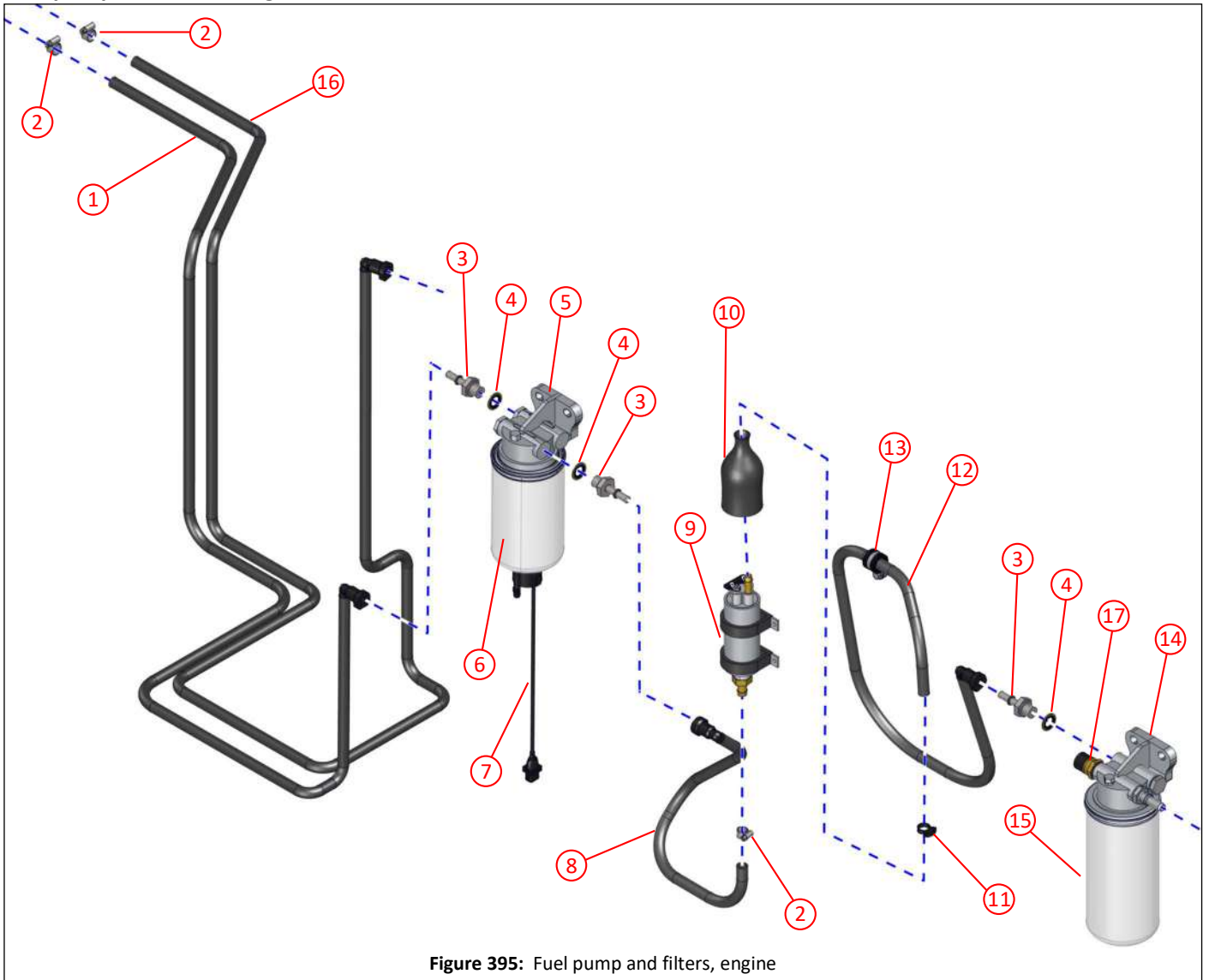

Figure 395: Fuel pump and filters, engine

Item	Part No	Qty	Description	
①	043030	1	Fuel hose, from tank to primary filter	
②	005136	3	Hose clamp, worm drive, No. 000 (ø9.5mm-ø12mm)	
③	042903	3	Adapter, quick change, M16 to 3/8" (SAE J2044)	
④	011217	3	Dowty seal M16	
⑤	041699	1	Fuel filter, primary, assembly includes items ⑥ and ⑦	351
⑥	042234	1	Filter element, fuel filter, primary	
⑦	045113	1	Water in fuel (WIF) sensor, fuel filter, with cable	331
⑧	043032	1	Fuel hose, from filter 1 to lift pump	
⑨	043370	1	Fuel lift pump, 24v	351
⑨	044515	1	Fuel lift pump, 12v	351
⑩	042604	1	Boot, fuel lift pump	
⑪	043709	1	Hose clip, plastic (ø15mm-ø17.1mm)	
⑫	043034	1	Fuel hose, lift pump to secondary filter	
⑬	000200	1	P-clip, ø18, rubber sleeved	
⑭	043035	1	Fuel filter, secondary, assembly includes item ⑮	351
⑮	043786	1	Filter element, fuel filter, secondary	
⑯	043031	1	Fuel hose, return to tank	
⑰	043785	1	Pressure sensor, secondary fuel filter	

Exhaust stack, engine

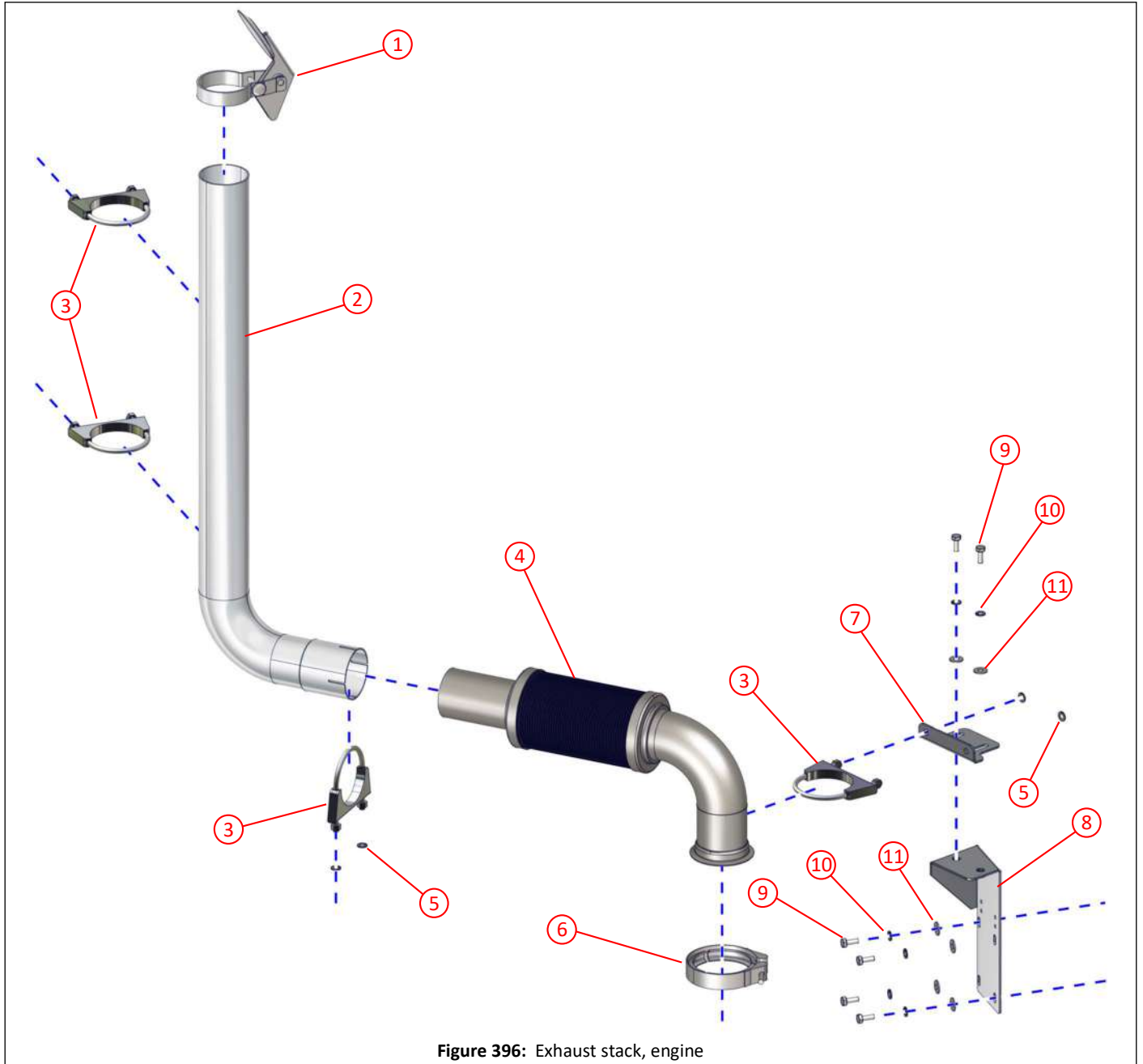

Figure 396: Exhaust stack, engine

Item	Part No	Qty	Description	
①	041907	1	Rain cap, exhaust	354
②	043342	1	Stack, exhaust	354
③	036831	4	U-clamp ø83, exhaust	
④	043338	1	Elbow, with flexible section, exhaust	354
⑤	011093	4	Spring washer M8	
⑥	041694	1	Vee clamp, exhaust	
⑦	043940	1	Bracket, exhaust u-clamp	354
⑧	043339	1	Bracket, exhaust elbow	354
⑨	011010	6	Set screw M8 x 20	
⑩	011093	6	Spring washer M8	
⑪	011092	6	Plain washer M8	

Air intake stack, engine

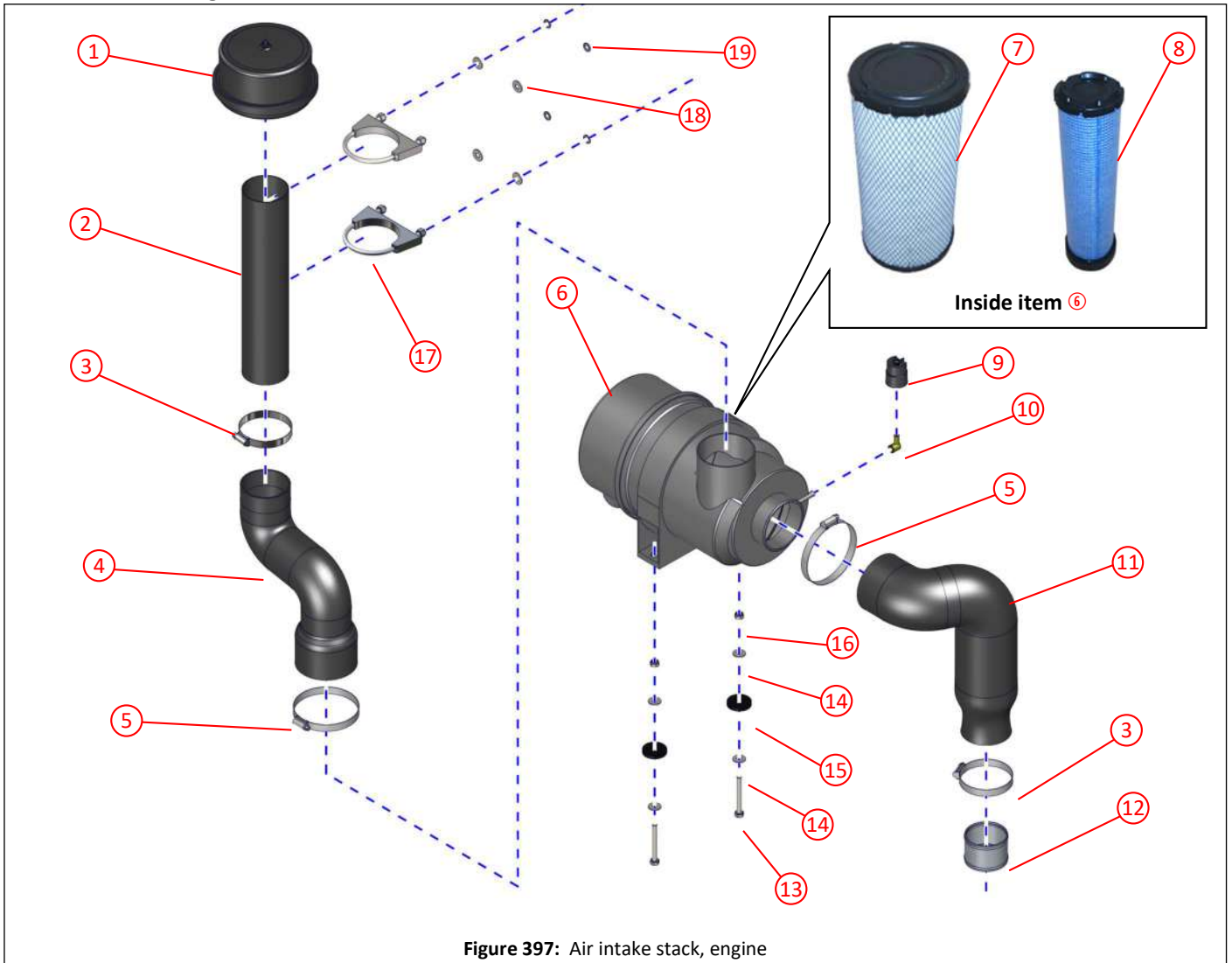

Figure 397: Air intake stack, engine

Item	Part No	Qty	Description	
①	036022	1	Stack cap, air intake	355
②	042915	1	Stack, air intake	355
③	012931	2	Hose clamp, worm drive, No. 4 (ø70mm-ø90mm)	
④	042999	1	Hose B, air intake	355
⑤	003003	2	Hose clamp, worm drive, No. 5 (ø90mm-ø120mm)	
⑥	025279	1	Air cleaner assembly, includes items ⑦ and ⑧	355
⑦	025280	1	Element, main, air cleaner	
⑧	025281	1	Element, safety, air cleaner	
⑨	042136	1	Sender, filter blocked, 5.0kPa	
⑩	034343	1	Elbow, filter blocked sender	
⑪	042812	1	Hose A, air intake	355
⑫	041896	1	Stub, air intake	
⑬	011018	2	Bolt M8 x 70	
⑭	011092	4	Plain washer M8	
⑮	012969	2	Washer, rubber, ø12 x ø40 x 6	
⑯	011073	2	Nyloc nut M8	
⑰	036831	2	U-clamp ø83, exhaust	
⑱	011092	2	Plain washer M8	
⑲	011093	2	Spring washer M8	

Expansion tank, engine

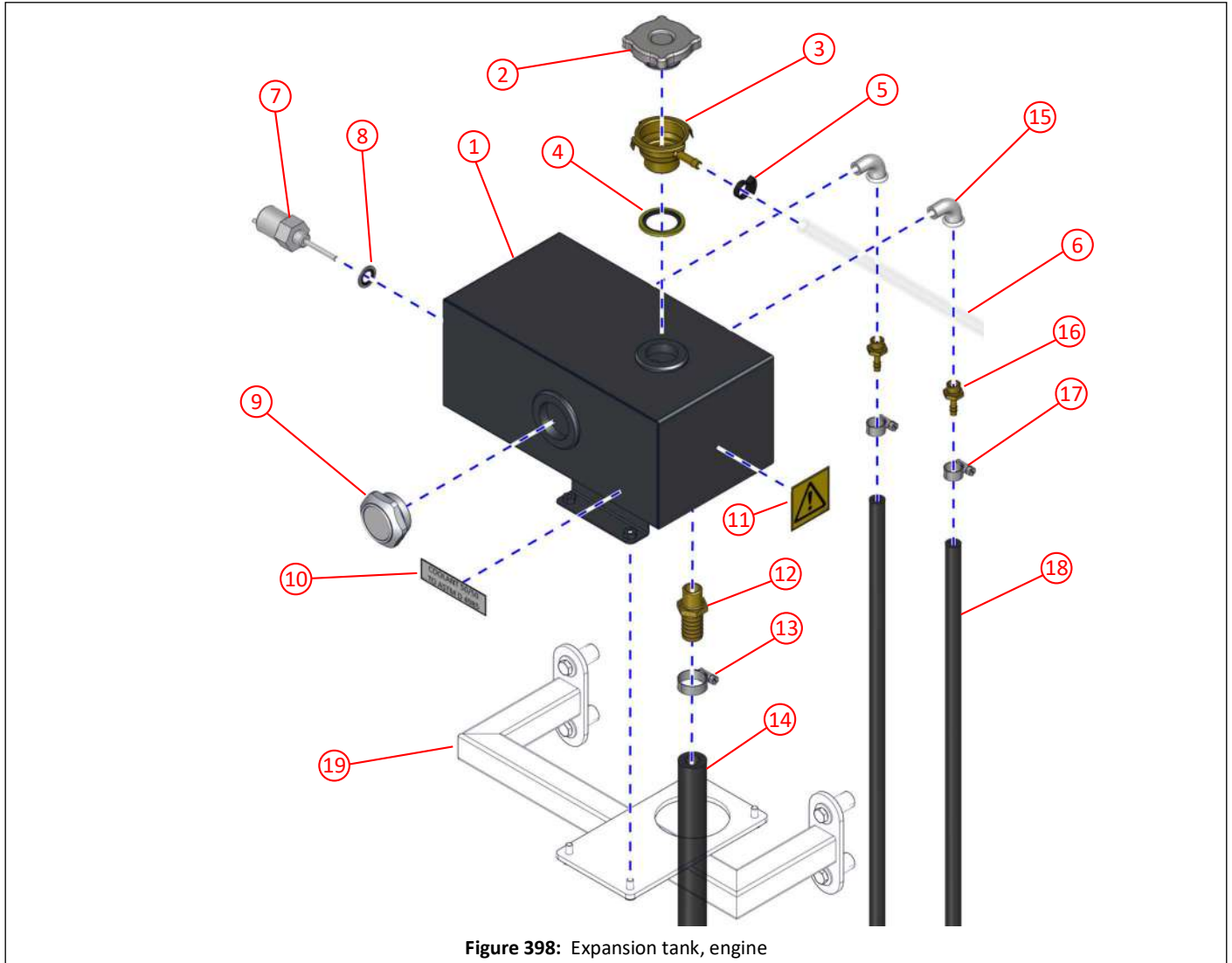

Figure 398: Expansion tank, engine

Item	Part No	Qty	Description	
①	041936	1	Expansion tank	359
②	041945	1	Cap, filler neck, expansion tank	
③	041944	1	Filler neck, expansion tank	
④	011156	1	Dowty seal 1" BSP	
⑤	005024	1	Cable tie, T18R, black	
⑥	010951	As req	Hose, $\frac{3}{8}$ " , clear	
⑦	041698	1	Sensor, coolant level, expansion tank	331
⑧	011216	1	Dowty seal M14	
⑨	042333	1	Bulls-eye sight glass, $1\frac{1}{4}$ " BSP	
⑩	036223	1	Label - Coolant grade	
⑪	043693	1	Label - Hazard	
⑫	025181	1	Adapter, $\frac{1}{2}$ " BSP x $\frac{3}{4}$ " hose tail	
⑬	010517	1	Hose clamp, worm drive, No 0X ( $\phi 18-\phi 25$ )	
⑭	002188	As req	Hose, $\frac{3}{4}$ " R6	
⑮	010910	2	Elbow, M/F, $\frac{1}{4}$ " BSP	
⑯	010925	2	Adapter, $\frac{1}{4}$ " BSP x $\frac{1}{4}$ " hose tail	
⑰	010516	2	Hose clamp, worm drive. No M00 ( $\phi 11-\phi 16$ )	
⑱	001035	As req	Hose, 8mm	
⑲	042989	1	Mounting bracket, expansion tank	359

Combined intercooler/radiator/hydraulic oil cooler, engine

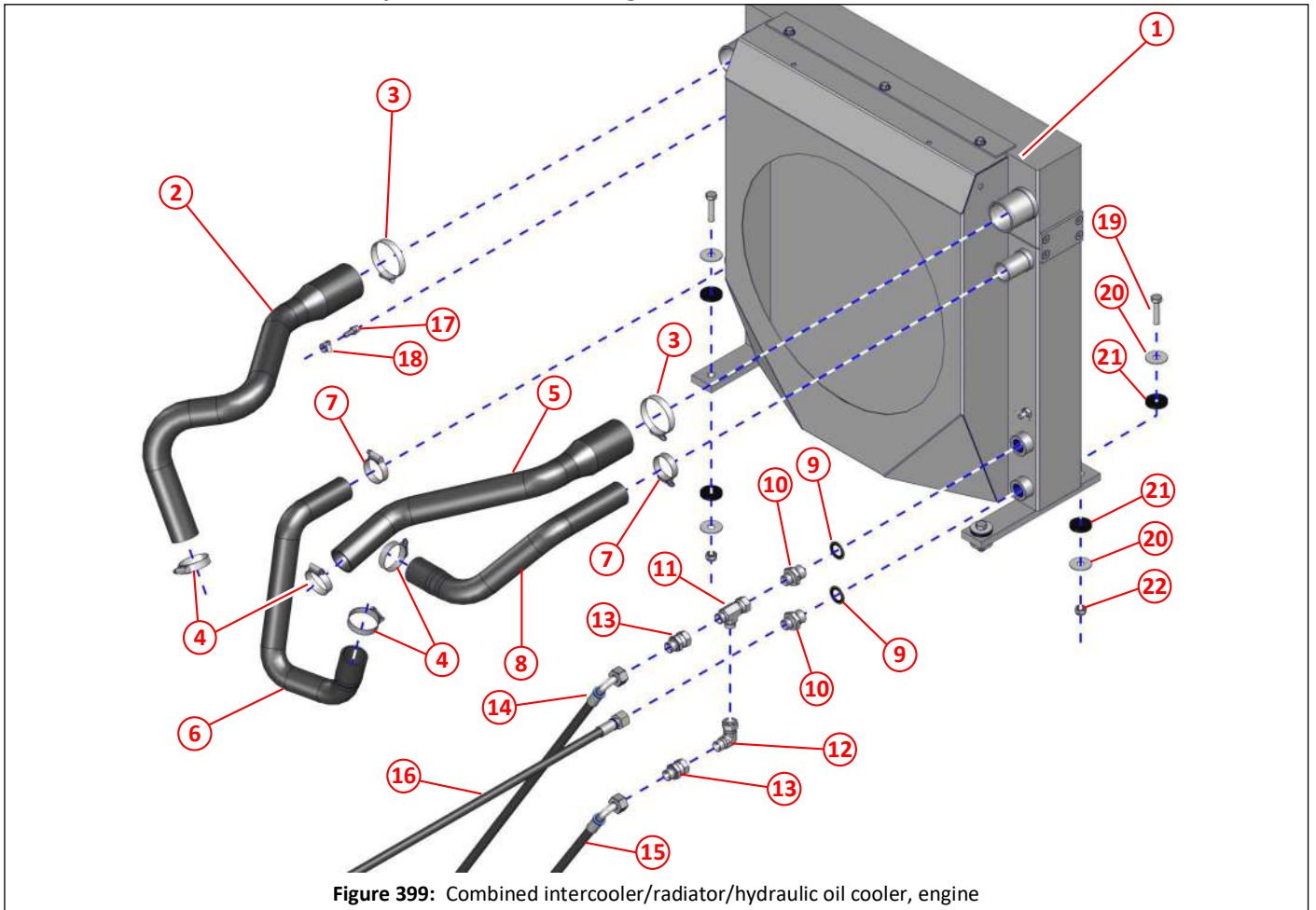

Figure 399: Combined intercooler/radiator/hydraulic oil cooler, engine

Item	Part No	Qty	Description	
①	042800	1	Combined intercooler/radiator/hydraulic oil cooler	348
②	042893	1	Intercooler hose 'A'	
③	010595	2	Hose clamp, worm drive, No 3 (ø55-ø70)	
④	012927	5	Hose clamp, worm drive, No 2 (ø40-ø55)	
⑤	042894	1	Intercooler hose 'B'	
⑥	042896	1	Coolant hose 'B'	
⑦	003007	2	Hose clamp, worm drive, No 2A (ø35-ø50)	
⑧	042895	1	Coolant hose 'A'	
⑨	002082	2	Dowty Seal M26	
⑩	002074	2	Adapter, M/M, M26 x ½" BSP	
⑪	011182	1	Tee, ½" BSP, nut on run	
⑫	011173	1	Elbow, swivel, M/F, ½" BSP	
⑬	011177	2	Adapter, swivel, M/F ½" BSP	
⑭	001328	1	Hose, ½" BSP x 810, straight and 90° ends, to Port T2 on main valve block	
⑮	001271	1	Hose, ½" BSP x 960, straight and 90° ends, to Port T1 on main valve block	
⑯	001308	1	Hose, ½" BSP x 2200, straight ends, from tank	
⑰	006044	1	Adapter, ¼" BSP male x 8mm hose tail	
⑱	010516	1	Hose clamp, worm drive, No M00 (ø11-ø16)	
⑲	000024	4	Set screw M12 x 50	
⑳	013448	8	Washer ø13 x ø40 x 2	
㉑	012969	8	Rubber washer, ø12 x ø40 x 6	
㉒	011077	4	Nyloc nut M12	

## Other components, engine

Part No	Description	
043782	Valve cover gasket	
043783	Head gasket	
043784	Seal, rear main	
043788	Water pump, coolant	
043791	Seal, front main	
043792	Sump gasket	
043800	Oil pump	
043806	Thermostat	
043811	Ring gear	
043813	Seal, oil pump	
043817	EGR module, 24v	
043819	EGR module, 12v	
045113	Water in fuel (WIF) sensor cable	
045711	Sealing ring	
045712	Screw plug	
045714	Packing compound	
045732	Seal, water pump	
043222	Dipstick	424
043223	O-ring, dipstick	
041968	Coolant level switch	331

**i** For other parts of the DEUTZ TCD 3.6 L4 engine that are not mentioned in this book please contact Scarab Parts Department, your local Scarab agent or DEUTZ. Have your engine serial number ready and if contacting Scarab have your sweepers serial number as well.



**Centaflex coupling and fan pump housing plate, engine**

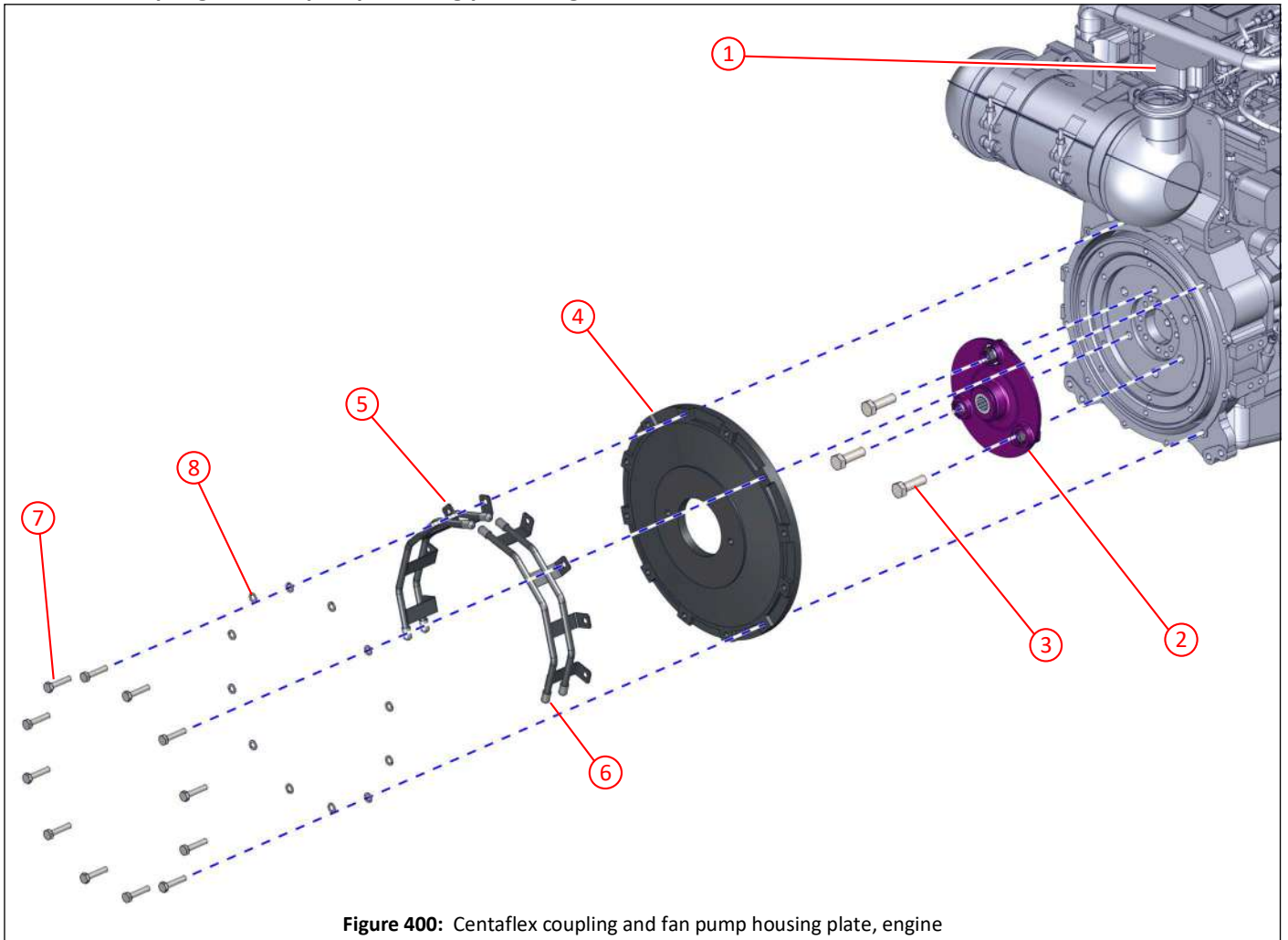

**Figure 400:** Centaflex coupling and fan pump housing plate, engine

Item	Part No	Qty	Description
①		1	DEUTZ TCD 3.6 L4 engine
②	043081	1	Centaflex KE coupling
③	000473	3	Set screw M16 x 2 x 50
④	042813	1	Fan pump housing plate
⑤	042979	2	Cable guide, fan pump housing plate
⑥	043065	8	Pipe cap $\varnothing$ 12
⑦	000072	12	Set screw M10 x 45
⑧	011095	12	Spring washer M10



# Cab components

<i>Description</i>	<i>Page</i>
Cab components .....	442
General layout, cab components .....	442
Main control panel and operator screen mountings, cab components .....	443
Main control panel and operator screen mountings, cab components, Freightliner M2106 DS .....	444
Auxiliary control panel (door pod) mountings, cab components .....	445
Brush pressure controls, cab components .....	446
Hopper controller remote, mountings, cab components .....	447
CR2012 cabinet module, slave node, mountings, cab components .....	448
Other components, cab components .....	449

General layout, cab components



Main controller, operator screen and auxiliary controller



Main controller, operator screen and extra camera screen



Hopper remote controller

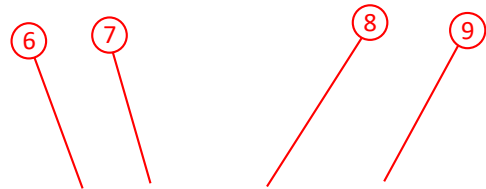

Brush pressure switches, pressure adjuster and gauge

Figure 401: General layout, cab components

Item	Part No	Qty	Description	
①			Main control panel	318,443
②			Auxiliary control panel (door pod)	319,445
③			Operator screen	320,443
④			Camera screen	321,
⑤			Hopper remote controller	320,447
⑥			Side brush pressure switch	306,446
⑦			Central brush (wide sweep) pressure switch	305,306,446
⑧			Pressure adjuster, brush	306,446
⑨			Pressure gauge, brush	306,446

**i** Please note that any mounting brackets etc. in the cab area are chassis specific, when ordering parts please have you sweepers serial number and also the type of chassis it is built on available.

Main control panel and operator screen mountings, cab components

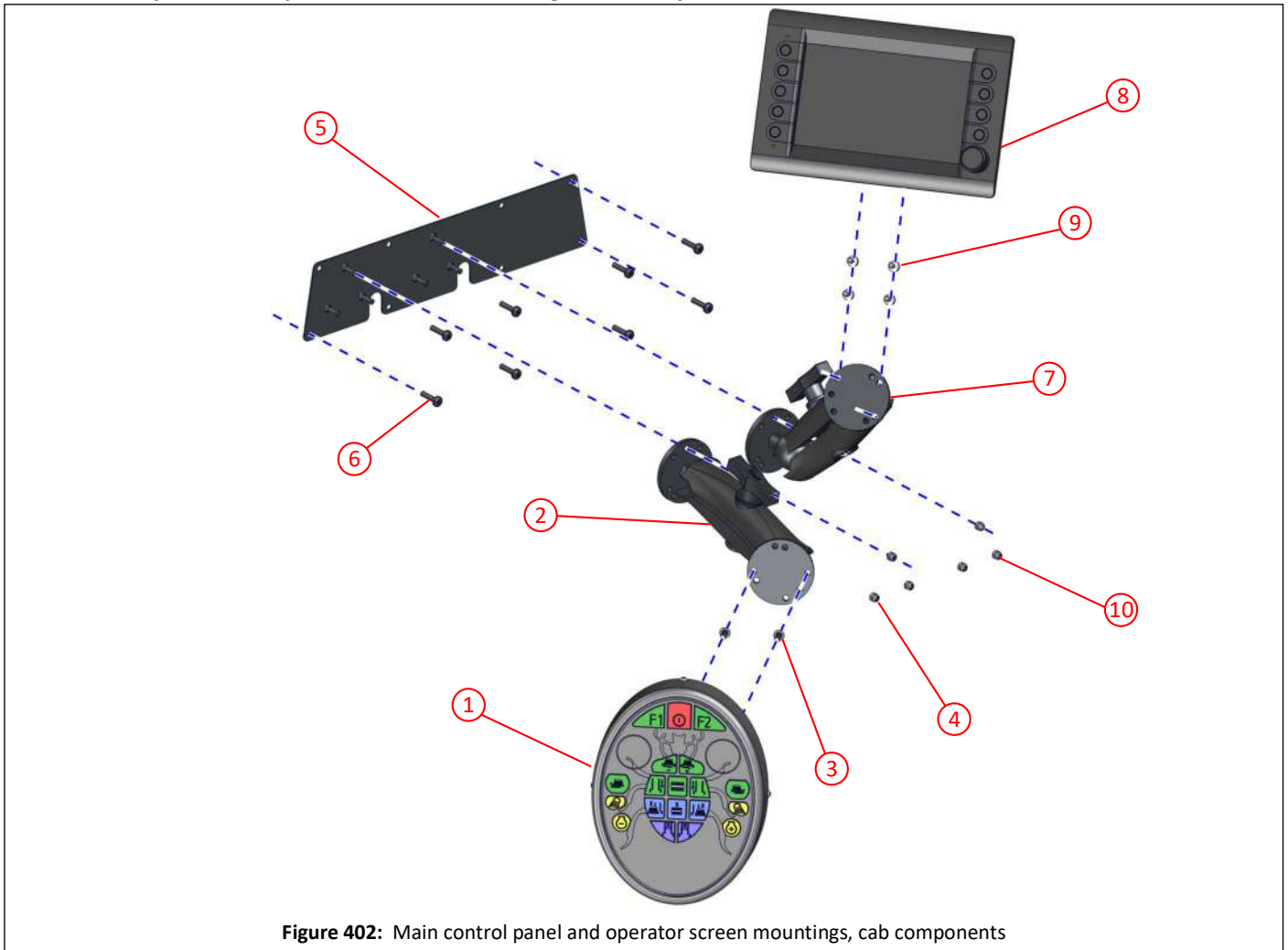

Figure 402: Main control panel and operator screen mountings, cab components

Item	Part No	Qty	Description	
①	037602	1	Main control panel, fascia and keypad	318,442
②	032108	1	Panel mount, adjustable	
③	000346	2	Socket button head screw M5 x 16, black	
④	000134	3	Nyloc nut M4	
⑤	042034 *	1	Mounting plate, control panel and operator screen, (DAF left hand drive shown)	
⑥	000402	8	Pan head Pozidrive screw M5 x 20	
⑦	032108	1	Panel mount, adjustable	
⑧	051274	1	Display screen, operator, CR1084, programmed	320,442
⑨	100103	4	Pan head Pozidrive screw M5 x 12	
⑩	000134	3	Nyloc nut M4	

\*. These items are chassis specific, when ordering parts please have your sweeper serial number and type of chassis it is built on available.

**i** Due to the many chassis and variants available it is not practical to list all of the fittings for attaching items to the chassis, please use appropriate fittings and if in any doubt contact Scarab Sweepers for advice.

Main control panel and operator screen mountings, cab components, Freightliner M2106 DS

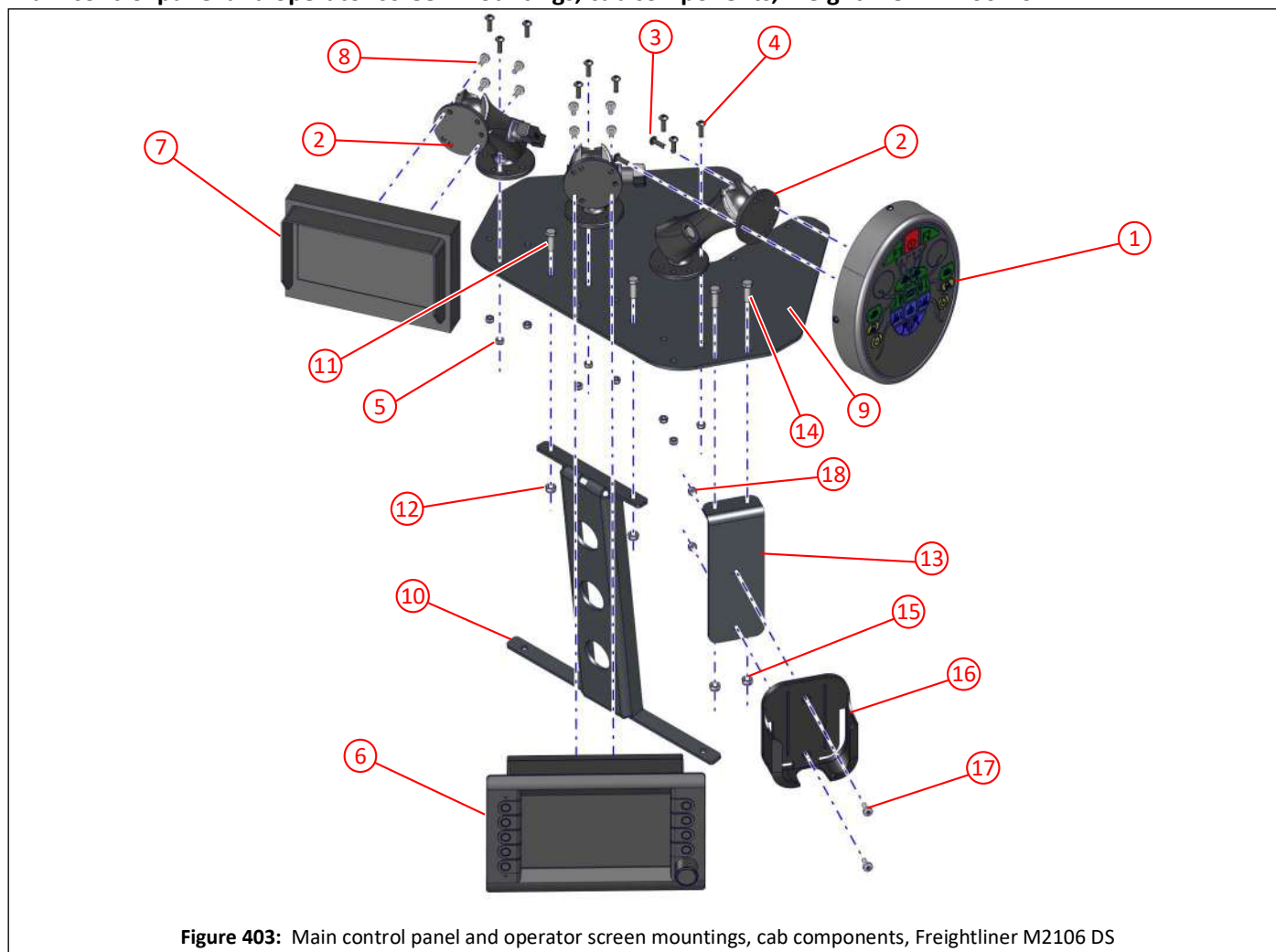

Figure 403: Main control panel and operator screen mountings, cab components, Freightliner M2106 DS

Item	Part No	Qty	Description	
①	037602	1	Main control panel, fascia and keypad	318,442
②	032108	3	Panel mount, adjustable	
③	000346	2	Screw, socket button head, M5 x 16, black	
④	000346	9	Screw, socket button head, M5 x 16, black	
⑤	000155	9	Nyloc nut M5	
⑥	051274	1	Display screen, operator, CR1084, programmed	320,442
⑦	040717	1	Camera monitor	
⑧	100103	8	Pan head Pozidrive screw M5 x 12	
⑨	046606	1	Dash plate, Freightliner M2106 DS	
⑩	046605	1	Support, dash plate, Freightliner M2106 DS	
⑪	011067	2	Set screw M6 x 20	
⑫	011071	2	Nyloc nut M6	
⑬	046604	1	Hopper controller mounting bracket, Freightliner M2106 DS	
⑭	011067	2	Set screw M6 x 20	
⑮	011071	2	Nyloc nut M6	
⑯	043691	1	Holster, hopper controller (PXL)	
⑰	100103	2	Screw, pan head pozidrive M5 x 12	
⑱	000155	2	Nyloc nut M5	

**i** Due to the many chassis and variants available it is not practical to list all of the fittings for attaching items to the chassis, please use appropriate fittings and if in any doubt contact Scarab Sweepers for advice.



Auxiliary control panel (door pod) mountings, cab components

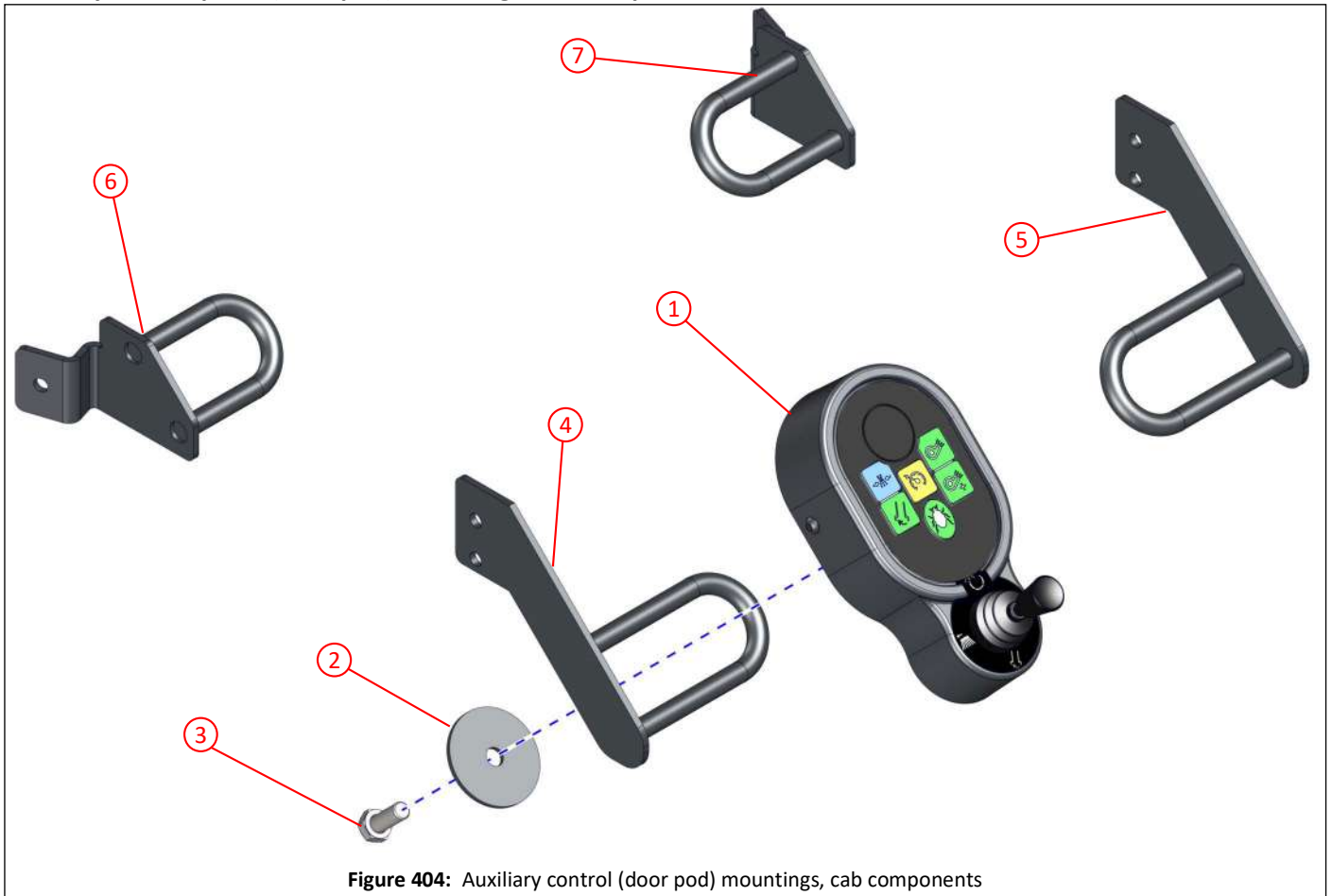

Figure 404: Auxiliary control (door pod) mountings, cab components

Item	Part No	Qty	Description	
①	037606	1	Auxiliary control panel (door pod), left hand, complete assembly	319,442
①	037607	1	Auxiliary control panel (door pod), right hand, complete assembly	319,442
②	037064	1	Lock washer, auxiliary control panel (door pod)	
③	011031	1	Set screw M10 x 25	
④	037866 *	1	Mount, left hand, auxiliary (door pod) controller, DAF/Renault/Volvo	
⑤	037296 *	1	Mount, right hand, auxiliary (door pod) controller, DAF/Renault/Volvo	
⑥	033427 *	1	Mount, left hand, auxiliary (door pod) controller, Iveco	
⑦	033317 *	1	Mount, right hand, auxiliary (door pod) controller, Iveco	

\*. These are examples of brackets for mounting the auxiliary controller, if needing to order, then please contact Scarab Parts Department and have your sweeper serial number and type of chassis it is built on available, to ensure correct parts selection.

**i** Due to the many chassis and variants available it is not practical to list all of the fittings for attaching items to the chassis, please use appropriate fittings and if in any doubt contact Scarab Sweepers for advice.

Brush pressure controls, cab components

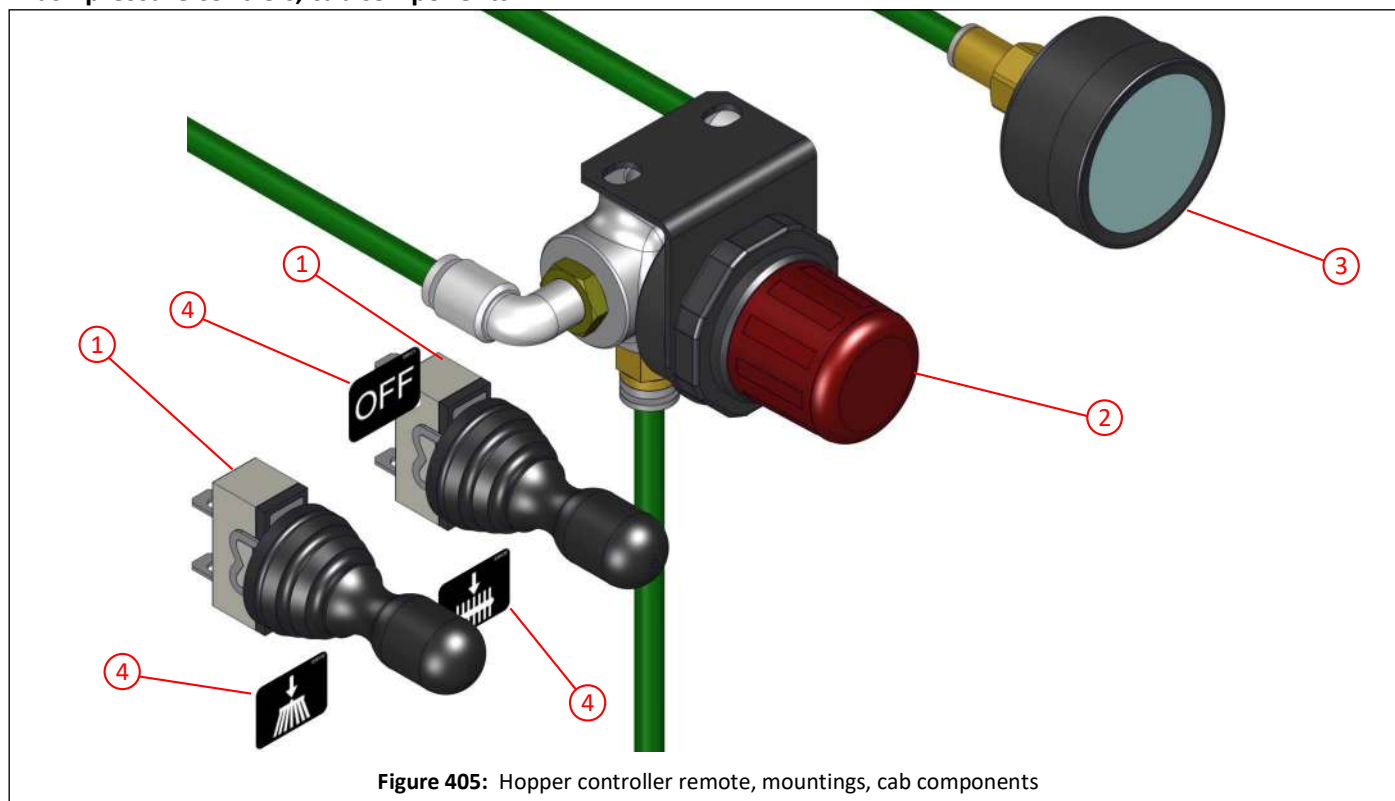

Figure 405: Hopper controller remote, mountings, cab components

Item	Part No	Qty	Description	
①		As req	Switch	306
②		1	Pressure regulator, mini, 0.5 - 3.5 bar	306
③		1	Pressure gauge, brush	306
④		As req	Labels	306,453

**i** Due to the many chassis and variants available it is not practical to list all the fittings for attaching these items, please contact Scarab Parts Department for advice on required mounting plates etc.

Hopper controller remote, mountings, cab components

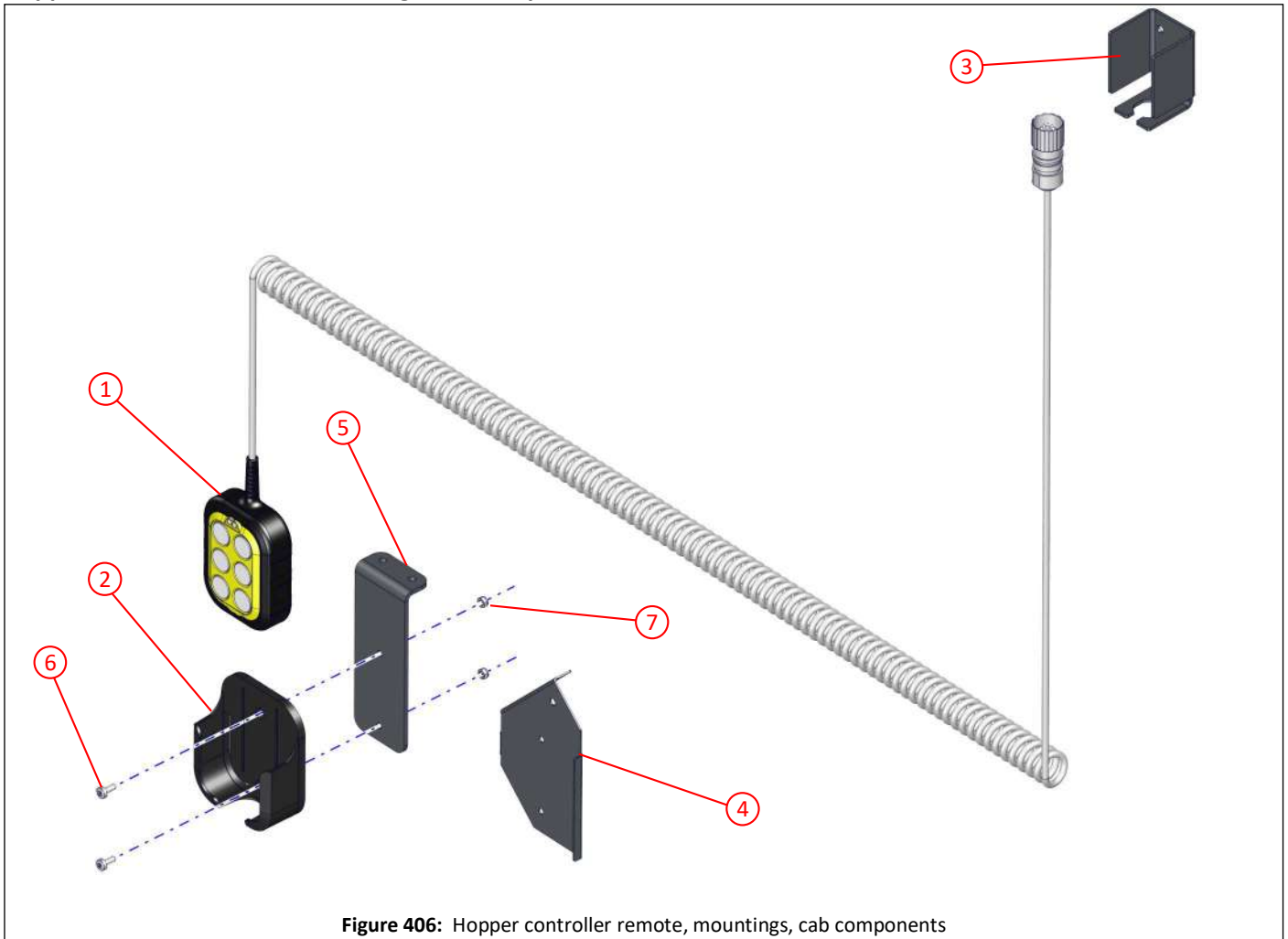

Figure 406: Hopper controller remote, mountings, cab components

Item	Part No	Qty	Description	
①	043688	1	Hopper controller (PXL)	
②	043691	1	Holster, hopper controller (PXL)	
③	037299	1	Bracket, cable control, hopper controller	
	044294	1	Hopper controller complete with holster, includes items ① and ②	
④	037898 *	1	Hopper controller mounting bracket, left hand, DAF	
⑤	046604 *	1	Hopper controller mounting bracket, Freightliner M2106 DS	
⑥	100103	2	Screw, pan head pozidrive M5 x 12	
⑦	000155	2	Nyloc nut M5	
NI	037047	1	Loom, hopper controller	330

\*. These are examples of brackets used to mount the remote controller holster to the chassis or other areas of the cab, if needing to order, then please contact Scarab Parts Department and have your sweeper serial number and type of chassis it is built on available, to ensure correct parts selection.

**i** Due to the many chassis and variants available it is not practical to list all of the fittings for attaching items to the chassis, please use appropriate fittings and if in any doubt contact Scarab Sweepers for advice.

## CR2012 cabinet module, slave node, mountings, cab components

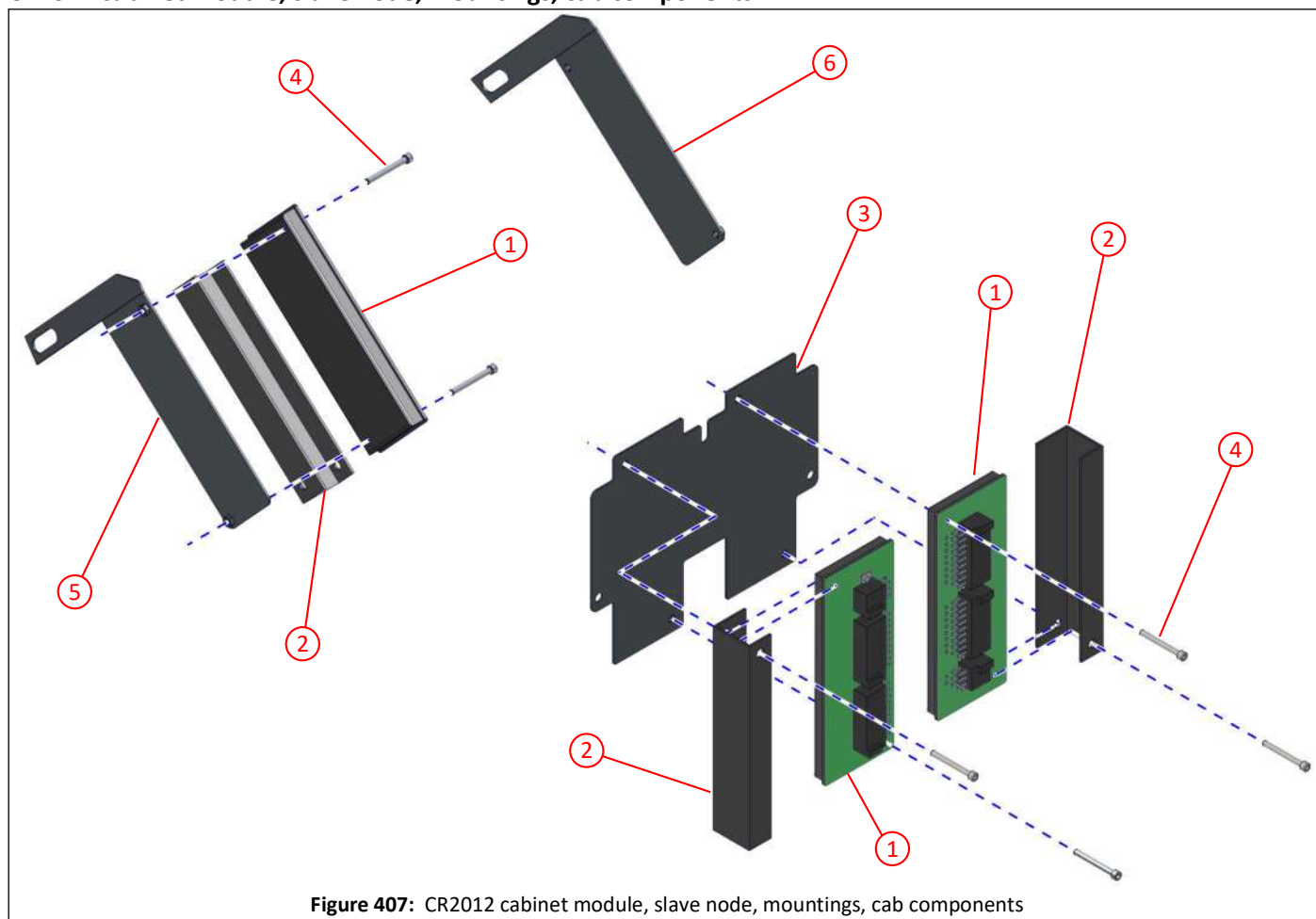

Figure 407: CR2012 cabinet module, slave node, mountings, cab components

Item	Part No	Qty	Description	
①	036799	3	CR2012 cabinet module, slave node, behind dash	320
②	004491	3	Cover, for CR2012 connections, 1 per CR2012	
③	032045 *	1	Mounting plate, double, CR2012, DAF	
④	000152	6	Socket cap head screw M4 x 35, 2 per CR2012	
⑤	042041 *	1	Mounting bracket, left hand drive, CR2012 (auxiliary controller (door pod)), DAF	
⑥	043073 *	1	Mounting bracket, right hand drive, CR2012 (auxiliary controller (door pod)), DAF	

\*. These are examples of brackets for mounting the CR2012, if needing to order, then please contact Scarab Parts Department and have your sweeper serial number and type of chassis it is built on available, to ensure correct parts selection.

**i** Due to the many chassis and variants available it is not practical to list all of the fittings for attaching items to the chassis, please use appropriate fittings and if in any doubt contact Scarab Sweepers for advice.

Other components, cab components

Part No	Description	
042049 *	Beacon switch, DAF	321
038543 *	Beacon switch, Renault	321
039672	Cable, M12 to USB	320
037048	Sounder	321
040717	Camera monitor	321
041534	Camera splitter	322
014718	Relay, 10/20 Amp, Beacon(s), 24v	322
011768	Relay, 10/20 Amp, Beacon(s), 12v	322
014718	Relay, 10/20 Amp, Ignition, 24v	322
011768	Relay, 10/20 Amp, Ignition, 12v	322

\*. Switches for other chassis manufacturers please contact Scarab Parts Department.

 For looms and other electrical items in the cab please refer to the "Electrical" section starting on page 317.





# Labels, decals and badges

<i>Description</i>	<i>Page</i>
Labels, decals and badges .....	452
Warning labels .....	452
Information labels .....	453
Decals and badges .....	454

Warning labels

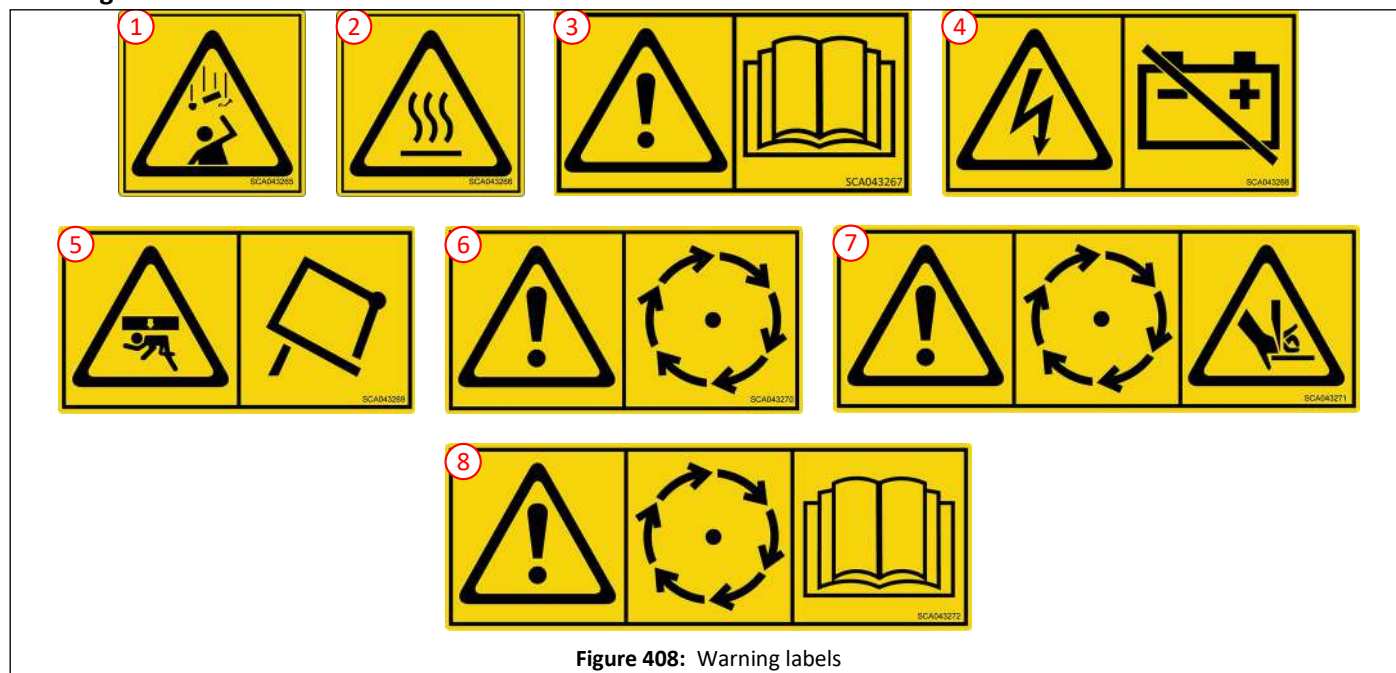

Figure 408: Warning labels

Item	Part No	Qty	Description
①	043265	As req	Label - Warning - Debris
②	043266	As req	Label - Warning - Hot surface
③	043267	As req	Label - Warning - Read the manual
④	043268	As req	Label - Warning - Electrical
⑤	043269	As req	Label - Warning - Use hopper prop
⑥	043270	As req	Label - Warning - Rotating parts
⑦	043271	As req	Label - Warning - Rotating parts and trap hazard
⑧	043272	As req	Label - Warning - Rotating parts, read the manual

Information labels

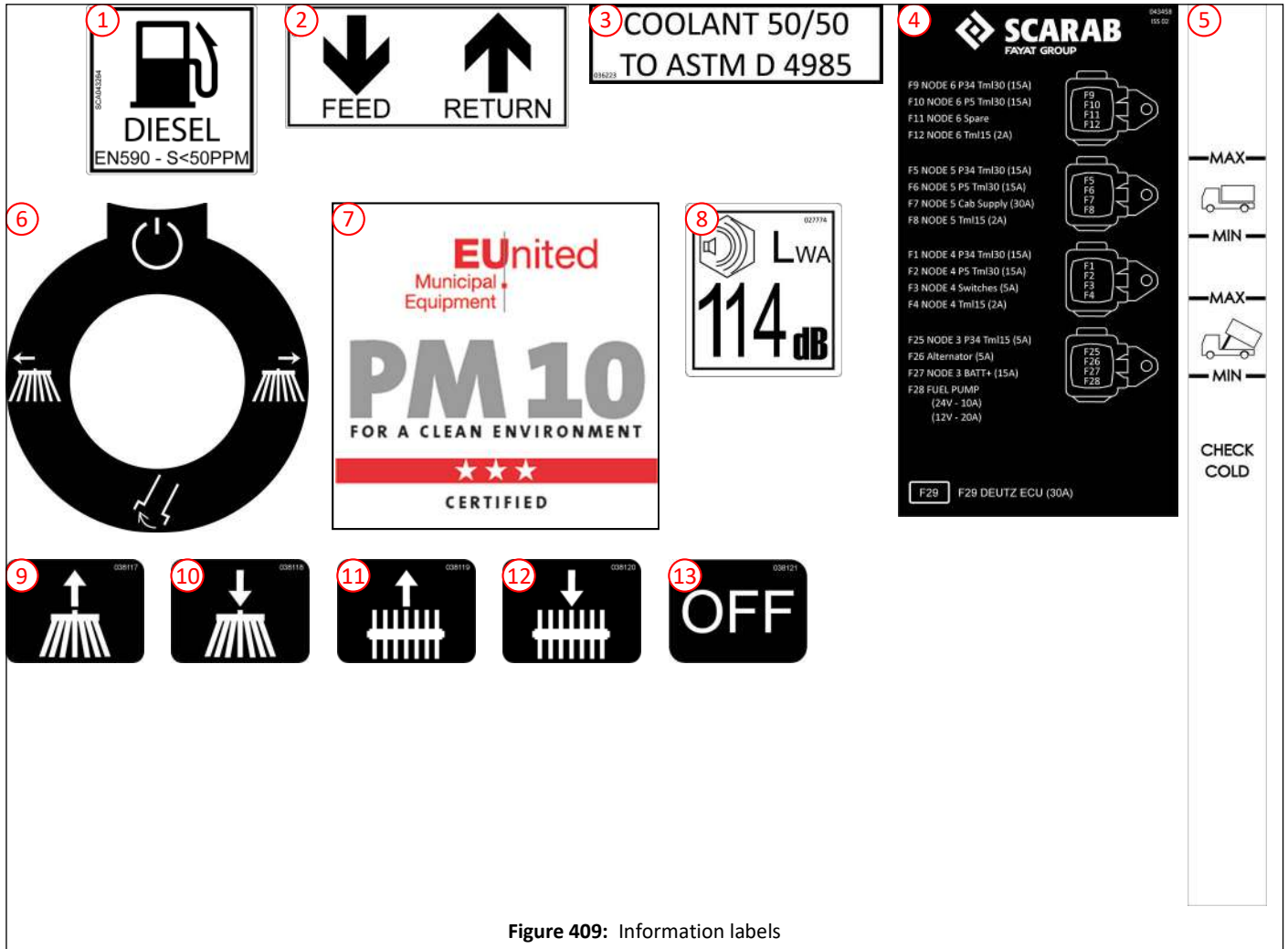

Figure 409: Information labels

Item	Part No	Qty	Description
①	043264	1	Label - Information - Diesel
②	043866	1	Label - Information - Fuel feed/return
③	036223	1	Label - Information - Coolant grade
④	043458	1	Label - Information - Fuses cabinet
⑤	044831	1	Label - Information - Hydraulic oil level
⑥	039545	1	Label - Information - Auxiliary control panel joystick
⑦	039869	1	Label - Information - PM10
⑧	027774	As req	Label - Information - Sound level 114dB
⑨	038117	1	Label - Information - Side brush up - turn on reduced pressure
⑩	038118	1	Label - Information - Side brush down - turn on increased pressure -
⑪	038119	1	Label - Information - Central brush (wide sweep) up - turn on reduced pressure
⑫	038120	1	Label - Information - Central brush (wide sweep) down - turn on increased pressure
⑬	038121	1	Label - Information - Brush pressures OFF

**i** Please note that not all labels will necessarily be on your sweeper.

Decals and badges

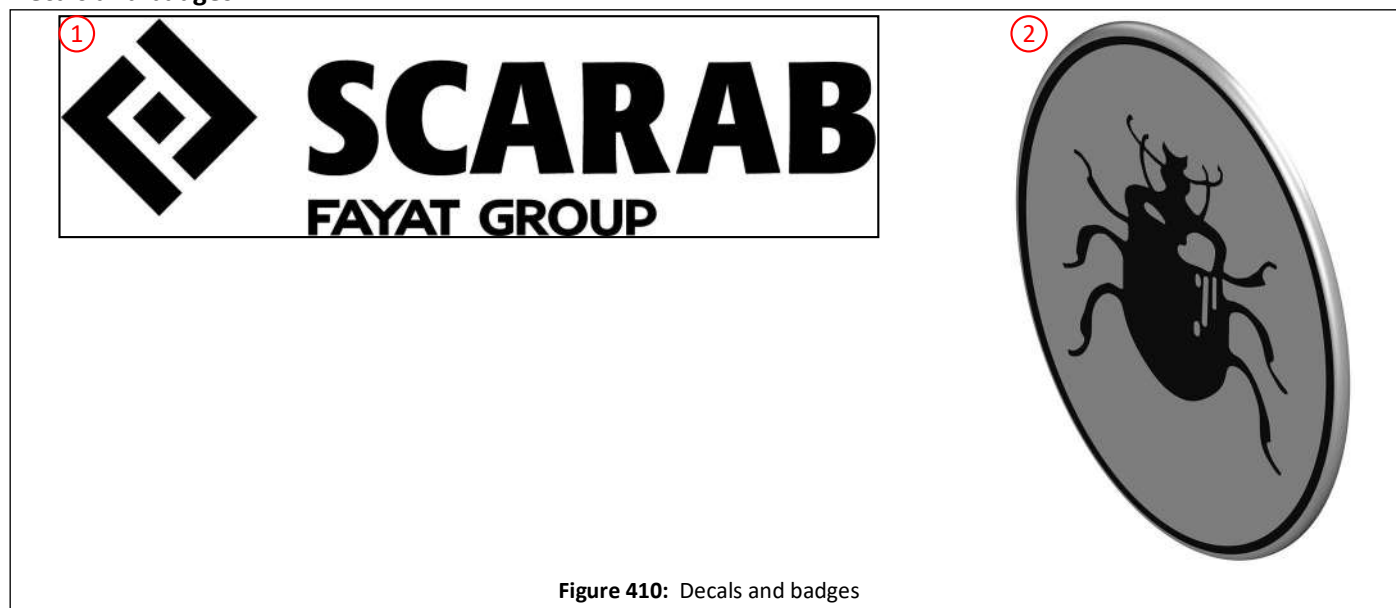

Figure 410: Decals and badges

Item	Part No	Qty	Description
①	042983	3	Scarab Fayat logo, black
②	040030	2	Scarab beetle badge, domed

# Multi-lingual glossary

<i>Description</i>	<i>Page</i>
English .....	456
Français .....	456
Italiano .....	456
English .....	475
Español .....	475
Svenska .....	475

English	Français	Italiano
<b>A</b>		
Access	Accès	Accesso
Accessories	Accessoires	Accessori
Accelerator	Accélérateur	Acceleratore
Actuator	Servomoteur	Attuatore
Adapter (adapt)	Adaptateur	Adattatore
Adapter Flange	Adaptateur à bride	Flangia adattatore
Adapter Plate	Adaptateur, à plaque	Piastra adattatore
Adapter, Straight	Adaptateur, droit	Adattatore in linea
Adjuster	Régulateur	Dispositivo di regolazione
Adjuster Kit	Régulateur, kit	Corredo dispositivo di regolazione
Adjuster Valve	Vanne de régulation	Valvola dispositivo di regolazione
Adjustable	Ajustable	Regolabile
Aerial	Antenne	Antenna
Air	Air	Aria
Air Cleaner	Filtre à air	Filtro aria
Air Conditioner	Climatiseur	Condizionatore aria
Air Cylinder	Cylindre d'air	Cilindro aria
Air Filter	Filtre à air	Filtro aria
Air Manifold	Collecteur d'air	Collettore aria
Air Mass Meter	Compteur d'air-massique	Flussometro di massa
Air Feed	Injecteur d'air	Alimentazione aria
Air Chute	Goulotte pneumatique	Lobo aria-aria
Air Outlet	Sortie d'air	Bocca di uscita aria
Air Muffler	Amortisseur d'air	Silenziatore aria
Air Pressure Regulator	Régulateur de pression d'air	Regolatore pressione aria
Air Ram	Vérin pneumatique	Pistone aria
Air Valve	Soupape d'air	Valvola di sfiato
Air Vent Pipe	Tuyau de refoulement d'air	Tubo di sfiato
Alternator	Alternateur	Alternatore
Alternator Interface	Alternateur, interface	Interfaccia alternatore
Aluminium (Alum)	Aluminium (alum)	Alluminio (Allum.)
Anchor	Ancre, dispositif d'ancrage	Ancora
Angle	Angle	Angolo
Antiluce Fastener	Fixation « Antiluce »	Dispositivo di fissaggio Antiluce
Amendment (Amdt.)	Modification (modif.)	Rettifica (rett.)
Amplifier	Amplificateur	Amplificatore
Arrangement	Disposition	Disposizione
Assembly (Assy)	Ensemble	Gruppo
Auto Blanking	Fermeture automatique	Autochiusura
Automatic	Automatique	Automatico



English	Français	Italiano
Auxiliary	Auxiliaire	Ausiliario
Axle	Essieu	Asse
Axle Beam	Essieu, fusée d'	Asta asse
Axle Bolt	Essieu, boulon d'	Bullone asse
Axle Breather	Essieu, reniflard d'	Sfiatatoio asse
Axle Carrier & Tube	Essieu, porte-essieu et tube	Supporto e tubo asse
Axle Front	Essieu, avant	Frontale asse
Axle Rear	Essieu, arrière	Retro asse
Axle Washer	Essieu, rondelle d'	Rondella asse
<b>B</b>		
Back Plate	Socle	Piastra di supporto
Bag	Sac	Borsa
Ball	Bille	Sfera
Ball End	Rotule	Estremità arrotondata
Ball Joint	Joint sphérique	Giunto sferico
Ball Valve	Vanne à boisseau	Valvola a sfera
Bar	Barre	Barra
Basin	Cuvette	Bacino
Battery	Batterie	Batteria
Battery Housing	Batterie, logement de	Sede batteria
Battery Terminals	Batterie, bornes	Terminali batteria
Battery Lead	Batterie, câble	Cavo batteria
Battery Tray	Batterie, plateau	Vassoio portabatteria
Beacon	Gyrophare	Segnale luminoso
Beacon Bar	Barre de gyrophare	Barra segnale luminoso
Beam	Phare	Fascio
Bearing	Roulement, palier	Cuscinetto
Bell Housing	Logement évasé	Sede campanello
Bellows	Soufflet	Soffietto
Belt	Courroie	Cinghia
Black	Noir	Nero
Blanking	Obturation	Tappaggio
Bleeper	Signal	Emettitore di segnali acustici
Blind Rivet	Rivet aveugle	Ribattino con spina inserita
Block	Bloc	Blocco
Blue	Bleu	Blu
Board	Carton	Piastra
Body	Corps	Corpo
Bolt	Boulon	Bullone
hex hd (hexagonal head)	Boulon à tête 6 pans	testa esagonale
skt hd (socket head)	Boulon à tête creuse	brugola

English	Français	Italiano
csk hd (counter-sunk head)	Boulon à tête fraisée	svasato
Boom	Flèche	Braccio
Boost	Suralimenter	Spinta
Bore	Alésage	Camera cilindrica
Boss	Moyeu, bossage	Mozzo
Bottom	Fond	Fondo
Bottle	Bouteille	Flacone
Box	Boîte	Scatola
Brace	Tirant	Braccio
Bracket (Brkt)	Support	Staffa
Brake	Frein	Freno
Brass Wing Nut	Ecrou à oreilles, en laiton	Galletto di ottone
Breather	Reniflard	Sfiatatoio
Broom	Balai	Scopa
Brown	Marron	Marrone
Brush	Brosse	Spazzola
Base	Base	Base
Buffer	Tampon	Respingente
Build	Construire, modèle	Costruzione
Bulb	Ampoule	Lampadina
Bulkhead	Cloison	Paratia
Bumper	Pare-chocs	Paraurti
Bump Stop	Butoir	Respingente
Bungee Cord	Corde « Bungee »	Cavo elastico
Bush	Manchon / Bague	Boccola
Buzzer	Vibreux	Cicalino
Button	Bouton	Pulsante
<b>C</b>		
Cable	Câble	Cavo
Caliper	Calibre	Pinza
Cam Shaft	Arbre à cames	Albero a camme
Camera	Caméra	Camera
Canopy	Auvent / Capot	Tettuccio
Cap	Capuchon	Cappuccio
Capping	Chapeau	Cornice
Carabiner	Carabine	Carabiner
Carrier	Porte, support	Portante
Case	Boîtier	Scatola
Casing	Boîtier	Involucro
Catalogue	Catalogue	Catalogo
Cab	Cabine	Cabina

English	Français	Italiano
Catch	Cliquet, disp. d'arrêt	Fermo
Caution	Notice « attention »	Attenzione
Centre	Centre	Centro
Chain	Chaîne	Catena
Chassis	Châssis	Chassis
Check	Contrôle	Controllo
Check Valve	Soupape d'arrêt / Clapet	Valvola di ritegno
Chute	Goulotte	Scivolo
Circlip	Circlip	Anello elastico
Circuit	Circuit	Circuito
Clamp	Collier	Morsetto
Cleaner	Nettoyage, dispositif de	Detergente
Clevis	Chape	Maniglione
Clip	Pince	Clip
Clutch	Embrayage	Frizione
Coach	Carrosserie	Carrozzeria
Coil	Bobine	Bobina
Collar	Bague de serrage	Piattello
Complete	Complet (complète)	Completo
Components	Composants	Componenti
Compressor	Compresseur	Compressore
Cone	Cône	Cono
Connector	Connecteur	Connettore
Connecting	Connectant	Connessione in corso
Con Rod (Connecting Rod)	Bielle	Biella
Continued (Cont.)	Suite	Continuazione (cont.)
Control (Cntrl)	Contrôle	Controllo (Cntrl)
Controller	Contrôleur	Unità di controllo
Conventional	Conventionnel	Convenzionale
Conversion (Conv)	Conversion	Conversione (Conv)
Cooler	Refroidisseur	Refrigerante
Cooling	Refroidissement	Raffreddamento
Copper	Cuivre	Rame
Core	Ame	Nucleo
Cotter	Goupille	Chiavetta trasversale
Coupling	Raccord / Accouplement	Accoppiamento
Cover	Couvercle	Coperchio
Cowling	Capotage	Cappottatura
Crank-case	Carter-moteur	Basamento
Cranked	Contre-coudé	Gambo piegato
Cross Member	Traverse	Traversa
Crown Wheel	Couronne d'entraînement	Corona dentata

English	Français	Italiano
<b>Curb</b>	Bord, bordure	Bordo
<b>Cylinder</b>	Cylindre	Cilindro
<b>D</b>		
<b>Damper</b>	Amortisseur	Smorzatore
<b>Deflector</b>	Défecteur	Deflettore
<b>Description</b>	Description	Descrizione
<b>Details</b>	Informations	Dettagli
<b>Detergent</b>	Detergent	Detergente
<b>Diagram</b>	Diagramme	Diagramma
<b>Dial</b>	Cadran	Quadrante
<b>Diaphragm</b>	Diaphragme	Diaframma
<b>Diode</b>	Diode	Diodo
<b>Dipped Beam</b>	Feu de croisement	Anabbagliante
<b>Dipstick</b>	Jauge	Asta di livello
<b>Dipstick guide</b>	Jauge, guide de	Guida asta di livello
<b>Dipstick tube</b>	Jauge, tube de	Tubo asta di livello
<b>Directional</b>	Directionnel	Direzionale
<b>Dirt</b>	Impureté	Sporco
<b>Disc / Disk</b>	Disque	Disco
<b>Display</b>	Écran d'affichage	Visualizzatore
<b>Distributor</b>	Distributeur	Distributore
<b>Diverter</b>	Diviseur	Diverter
<b>Door</b>	Porte	Sportello
<b>Double</b>	Double	Doppio
<b>Dowel</b>	Cheville	Perno di riferimento
<b>Down</b>	Bas	Giù
<b>Dowty Seal</b>	Joint « Dowty »	Chiusura ermetica Dowty
<b>Drag Link Tube</b>	Tube de tige directrice	Tirante longitudinale comando sterzo
<b>Drain Plug</b>	Bouchon de vidange	Tappo di scarico
<b>Drive</b>	Entraînement	Trasmissione
<b>Drive Core</b>	Entraînement, âme d'	Nucleo trasmissione
<b>Drive Coupling</b>	Entraînement, raccord d'	Accoppiamento trasmissione
<b>Drive Dog</b>	Entraînement, crabot d'	Innesco trasmissione
<b>Drive Flange</b>	Entraînement, bride d'	Flangia trasmissione
<b>Drive Motor</b>	Entraînement, moteur d'	Motore principale
<b>Drive Pump</b>	Entraînement, pompe d'	Pompa trasmissione
<b>Drive Shaft</b>	Entraînement, arbre d'	Albero comando
<b>Drive Tube</b>	Entraînement, tube d'	Tubo trasmissione
<b>Dual Sweep</b>	Double balayage	doppia spazzata
<b>Dump Valve</b>	Soupape de décharge	Valvola di scarico rapido
<b>Dust</b>	Poussière	Polvere

English	Français	Italiano
<b>E</b>		
<b>Eccentric</b>	Excentrique	Eccentrico
<b>Elbow</b>	Coude	Gomito
<b>Electric</b>	Electrique	Elettrico
<b>Electrical</b>	Electrique	Elettrico
<b>Element</b>	Élément	Elemento
<b>Enclosure</b>	Enceinte	Alloggiamento
<b>End</b>	Extrémité	Estremità
<b>End Plate</b>	Extrémité, plaque d'	Piastra estremità
<b>End Cap</b>	Extrémité, chapeau d'	Cappuccio estremità
<b>Engine</b>	Moteur	Motore
<b>Exchange</b>	Echange	Scambio
<b>Exhaust</b>	Echappement	Scarico
<b>Exhaust Gas Recirculation (EGR)</b>	Recyclage de gaz d'échappement	Ricircolo gas di scarico
<b>Expansion</b>	Dilatation	Espansione
<b>Extended</b>	Dilaté	Esteso
<b>Extension</b>	Extension	Estensione
<b>Extinguisher</b>	Extincteur	Estintore
<b>F</b>		
<b>Fan</b>	Ventilateur	Ventola
<b>Fastener</b>	Fixation	Dispositivo di fissaggio
<b>Feed</b>	Alimentation	Alimentazione
<b>Female</b>	Femelle	Femmina
<b>Filler</b>	Remplisseur	Bocchettone di riempimento
<b>Filter</b>	Filtre	Filtro
<b>Finisher</b>	Finisseur	Finitore
<b>Fire</b>	Feu	Combustione
<b>First</b>	Premier	Primo
<b>Fishtail</b>	Queue de poisson / Cône	Coda di pesce
<b>Fit</b>	Emboîter / Monter	Montaggio
<b>Fitting</b>	Raccord	Montaggio
<b>Fixing</b>	Fixation	Rettifica
<b>Flange</b>	Bride	Flangia
<b>Flap</b>	Volet	Alettone
<b>Flash</b>	Flash	Flash
<b>Flexible (Flexi)</b>	Flexible	Flessibile (flexi)
<b>Floor</b>	Plancher	Pavimento
<b>Floorplate</b>	Plaque de sol	Base pavimento
<b>Flow</b>	Débit	Flusso
<b>Fluid</b>	Fluide	Fluidico

English	Français	Italiano
Flywheel	Volant	Volano
Foam	Mousse	Schiuma
Fog	Brouillard	Nebbia
Foot	Pied	Piede
Forward	Avant	Avanti
Frame	Bâti	Telaio
Front	Avant	Anteriore
Fuel	Carburant	Combustibile
Function	Fonction	Funzione
Fuse	Fusible	Fusibile
<b>G</b>		
Gain	Gain	Guadagno
Galvanised	Galvanisé	Zincato
Gantry	Portique	Cavalletto
Gas	Gaz	Gas
Gas Strut	Jambe à gaz	Puntone gas
Gasket	Garniture d'étanchéité	Guarnizione
Gauge	Manomètre	Calibro
Gauze	Gaze	Garza
Gear	Engrenage	Ingranaggio
Geared	A engrenages	Ingranato
Gearbox	Boîte de vitesses	Scatola del cambio
General	Général(e)	Generale
Glass	Verre	Vetro
Glow Plug	Bougie de préchauffage	Spina a incandescenza
Gobbler (Nozzle Tilt)	Gobbler (Inclinaison d' Embout)	Gobbler (Ugello Inclinazione)
Grab	Grappin	1. Estrattore a pinza (n)
Grease	Graisse	Grasso
Greaser	Graisser	Ingrassatore
Green	vert	Verde
Grey	gris	Grigio
Grill	gril	Griglia
Grip	manche	1. Presa (n)
Grub Screw	vis sans tête	Vite di riferimento
Grommet	virole	Anello di tenuta
Guard	Carter de protection	Riparo
Guide	Guide	Guida
<b>H</b>		
Hand	Côté	Mano
Hand Primer	Pompe à main, dispositif de	Pompetta di adescamento a mano



English	Français	Italiano
Hand Wash	Lavage à main	Lavaggio a mano
Handbrake	Frein à main	Freno a mano
Handle	Poignée	Maniglia
Hanger	Suspension	Supporto pendente
Harness	Harnais	Cablaggio
Head	Tête	Testa
Headlamp	Phare	Faro
Heat	Chaleur	Calore
Heatshield	Bouclier thermique	Scudo termico
Heater	Chauffage	Riscaldatore
High Pressure	Haute pression	Alta pressione
Hi Tip	Bennage en hauteur	Punta alta
Hinge	Charnière	Cerniera
Hinged	Charnière, à	Incernierato
Holder	Porte-outil	Staffa di supporto
Hooks	Crochets	Ganci
Hopper	Trémie	Serbatoio con scarico sul fondo
Horn	Avertisseur sonore	Avvisatore acustico
Hose	Tuyau flexible	Tubo flessibile
Hose Tail	Tuyau flexible, bout de	Raccordo tubo flessibile
Hot	Chaud	Caldo
Hour Meter	Compteur horaire	Contaore
Housing	Logement	Alloggiamento
Hub	Manchon	Mozzo
Hydraulic	Hydraulique	Idraulico
Hydrant	Bouche d'incendie	Idrante
Hydrant Filler	Bouche d'incendie, disp. de remplissage	Filtro idrante
Hydrant Hose	Bouche d'incendie, tuyau souple	Tubo idrante
Hydrostatic	Hydrostatique	Idrostatico
<b>/</b>		
Identification	Identification	Identificazione
Idle	Inactif / Ralenti	Inattivo
Ignition (Ign)	Contact	Accensione (Acc)
Illuminated	Eclairé	Illuminato
Illustrated	Illustré	Illustrato
Illustration	Illustration	Illustrazione
Impellor	Rotor / Turbine	Girante
Inclusive	Compris	Inclusivo
Information (Info)	Informations	Informazioni (Info)
In	Entré	Dentro
Inlet	Entrée	Ammissione

English	Français	Italiano
Inlet Cone	Entrée, cône d'	Cono di ammissione
Inlet Pipe	Entrée, tuyau d'	Tubo di ammissione
Injection Pump	Pompe d'injection	Pompa d'iniezione
Injector	Injecteur	Iniettore
Injector Pipe	Tuyau d'injection	Tubo iniettore
Input	Entrée	Ingresso
Inseal Strip	Bande d'étanchéité	Guarnizione sigillante
Insert	Insert	Inserito
Insertion	Insertion	Inserimento
Installation	Installation	Installazione
Instrument	Instrument	Strumento
Insulator	Isolateur	Isolante
Inter Cooler	Refrigerateur intermédiaire	Refrigeratore intermedio
Interior	Intérieur	Interno
Interim	Intérimaire	Interim
Internal	Interne	Interno
Item	Article	Articolo
<b>J</b>		
Jet	Jet	Getto
Joint	Joint	Giunto
Joystick	Joystick	Joystick
Jubilee Clip	Pince crocodile	Fermaglio Jubilee
Junction	Jonction	Incrocio
<b>K</b>		
Key	Clé	Chiave
Key Switch	Interrupteur à clé	Interruttore a chiavetta
Kerb	Bordure	Bordo (as in pavement)
King Pin	Axe-pivot	Perno di sterzaggio
King Post	Poinçon de façade	Puntone di sostegno
Kit	Kit	Corredo
Knob	Bouton	Manopola
<b>L</b>		
Label	Etiquette	
Lamp	Lampe	Lampada etichetta
Work Lamp	Lampe de travail	Lampada da lavoro
Head Lamp	Projecteur	Faro
Side Lamp	Lampe latérale	Luce di posizione
Lance	Lance	Lancia

English	Français	Italiano
Lap Joint	Joint à recouvrement	Giunto a sovrapposizione
Large	Grand	Grande
Latch	Verrou	Serratura
Lead	Fil	Cavo
L.E.D. (Light Emitting Diode)	Diode électroluminescente	LED (Diodo a emissione luminosa)
Leash	Laisse	Maglia
Left	Gauche	Sinistra
Left Hand Drive (LHD)	Conduite à gauche	Guida a sinistra (LHD)
Leg	Jambe	Gamba
Length	Longueur	Lunghezza
Lens	Objectif	Lente
Level	Niveau	Livello
Lever	Levier	Leva
Lid	Couvercle	Coperchio
Lift	Ascenseur	Sollevare
Lifting	Levage	Sollevamento
Light	Feux	Luce
Side Light	Feux latéraux	Luce di posizione
Head Light	Phare	Faro
Rear Light	Feu arrière	Fanale di coda
Brake Light	Feux stop	Luce freno
Interior Light	Eclairage intérieur	Luce abitacolo
Fog Light	Feu antibrouillard	Faro antinebbia
Linch Pin	Axe d'essieu	Acciarino
Lining	Revêtement	Rivestimento interno
Link	Maillon	Articolazione
Linkage	Tringlerie	Sistema di leve
Litre	Litre	Litro
List	Liste	Lista
Load	Charge	Carico
Located	Situé	Posizionato
Lock	Verrou	Fermo
Locknut	Ecrou de blocage	Controdado
Locker	Armoire	Armadietto
Locking	Verrouillage	Serraggio
Long	Long	Lungo
Loom	Métier	Cablaggio
Loop	Boucle	Circuito elettrico ad anello
Low Pressure	Basse pression	Bassa pressione
Lower	Baisser	Inferiore
Lubricant	Lubrifiant	Lubrificante
Lubrication	Lubrification	Lubrificazione

English	Français	Italiano
<b>M</b>		
Machine	Machine	Macchina
Magnet	Aimant	Magnete
Magnetic	Magnétique	Magnetico
Main	Principal(e)	Principale
Male	Mâle	Maschio
Management	Gestion	Gestione
Manifold	Collecteur	Collettore
Manual	Manuel	Manuale
Manufactured	Fabriqué	Fabbricato
Marker Lamp	Lampe signal	Lampada di segnalazione
Master	Maître	Principale
Master Cylinder	Maître-cylindre	Cilindro principale
Maximum (Max)	Maximum (maxi)	Massimo (max.)
Mesh	Tamis	Maglia
Metal	Métal	Metallo
Meter	Mètre	Calibro
Micro Switch	Micro-contact	Microinterruttore
Minimum (Min)	Minimum (mini)	Minimo (min.)
Mirror	Miroir	Specchio
Miscellaneous	Divers	Miscellanea
Modified	Modifié	Modificato
Module	Module	Modulo
Monitor	Moniteur	Monitor
Motor	Moteur	Motore
Mount	Monture	Montaggio
Mounted	Monté	Montato
Mounting	Châssis / Support	Montaggio
Mud Flaps	Bavettes de garde-boue	Paraspruzzi
Mud Guard	Garde-boue	Parafango
Muffler	Amortisseur	Marmitta
Multi Function	Multifonctions	Multifunzionale
<b>N</b>		
N/A (Not Applicable)	S/O (sans objet)	N/D (Non disponibile)
Narrow	Etroit	Stretto
Near side	Côté trottoir	Lato guida
Negative	Négatif	Negativo
Neutral	Neutre	Neutro
New	Nouveau (nouvelle)	Nuovo
Nipple	Manchon	Raccordo filettato

English	Français	Italiano
No	Non	N. (Numero)
Non Return	Anti-retour	Non ritorno
Normal	Normal	Normale
Note	Note	Nota
Nozzle	Embout / Buse	Ugello
Number	Numéro	Numero
Numerical	Numérique	Numerico
Nut	Ecrou	Dado
Nyloc Nut	Ecrou « Nyloc »	Dado Nyloc
Hex Nut	Ecrou hexagonal	Dado a testa esagonale
Plain Nut	Ecrou normal	Dado liscio
Self Locking Nut	Ecrou autobloquant	Dado autobloccante
Thin Nut	Ecrou mince	Dado sottile
Nylon Tube	Tube de nylon / Nylon, tube de	Tubo di nylon
<b>O</b>		
Obsolete	Périmé	Obsoleto
Off	Arrêt	1. Spento 2. Inattivo
Off Side	Côté route	Lato passeggero
Oil	Huile	Olio
Olive	Olive	Oliva
On	Marche	1. Acceso 2. Attivo
Open	Ouvrir	Aprire
Opened	Ouvert(e)	Aperto
Opening	Ouverture	Apertura
Operating	Fonctionnement, de	Operativo
Option	Option	Opzione
Optional	Optionnel(le)	Opzionale
Orange	Orange	Arancione
Original	Original	Originale
O Ring	Joint torique	Anello di tenuta toroidale
Out	Sorti(e)	1. Fuori 2. Esterno
Outer	Extérieur(e)	Esterno
Outlet	Sortie	Sbocco
Output	Production	Uscita
Overhead	Surélevé	in testa
Overload	Surcharge	Sovraccarico
<b>P</b>		
Packer	Garniture d'étanchéité	Imballatore
Panel	Panneau	Pannello
Part	Pièce	Ricambio

English	Français	Italiano
Pedal	Pédale	Pedale
Pick-up	Prendre / en lever	Ripresa
Pilot (pressure)	Pilote	Pilota
Pin	Cheville	Perno
Pinion	Pignon	Pignone
Pink	Rose	Rosa
Pipe	Tuyau	Tube
Piping	Tuyauterie	Tubazione
Piston	Piston	Pistone
Pivot	Pivot	Perno di testa
Plastic	Plastique, matière	Plastica
Plate	Plaque	Piastra
Plinth	Plinthe	Base
Plug	Bouchon / Prise électrique	Spina
Point	Point	Punto
Poppet Valve	Soupape / Clapet	Valvola supporto verticale
Ports	Orifices	Porte
Position	Position	Posizione
Positioned	Positionné(e)	Posizionato
Post	Montant	Montante
Potentiometer	Potentiomètre	Potenziometro
Power	Puissance	Potenza
Pneumatic (See Also Air)	Pneumatique	Pneumatico (vedi anche Aria)
Pressure	Pression	Pressione
Primer	Amorce / Apprêt	Innesco
Production	Production	Produzione
Prop	Support	Puntello
Propshaft	Arbre de transmission	Albero puntello
Pull	Tirer	Tirare
Pulley	Poulie	Puleggia
Pulsation	Pulsation	Pulsazione
Pulse	Impulsion	Polso
Pump	Pompe	Pompa
Purple	Violet	Porpora
<b>Q</b>		
Quick Release	Rapide, raccord	Disinnescio rapido
<b>R</b>		
Radiator (Rad)	Radiateur	Radiatore (rad)
Raise	Soulever	Sollevare
Raised	Soulevé(e)	Sollevato



English	Français	Italiano
Ram	Vérin	Pistone
Ratio	Rapport	Rapporto
Rear	Arrière	Retro
Red	Rouge	Rosso
Reducer	Réducteur	Riduttore
Reducing	Réduction, de	Riduzione
Reduction	Roue / Enrouleur	Riduzione
Reel	Bobine	Bobina
Refer	Voir	Riferimento
Refill	Remplir	Rabbocco
Regulator	Régulateur	Regolatore
Related	Relatif	Correlato
Relay	Relais	Relè
Release	Dégagement	Disinnesco
Relief Valve	Soupape de sûreté	Valvola di sfogo
Remote	A distance / Distance, à	Remoto
Repair	Réparation	Riparazione
Replacement	Remplacement	Sostituzione
Resister	Résistance	Resistore
Refill	Remplir	Rabbocco
Regulator	Régulateur	Regolatore
Related	Relatif	Correlato
Relay	Relais	Relè
Release	Dégagement	Disinnesco
Relief Valve	Soupape de sûreté	Valvola di sfogo
Remote	A distance / Distance, à	Remoto
Repair	Réparation	Riparazione
Replacement	Remplacement	Sostituzione
Resister	Résistance	Resistore
Restrictor	Restriction	Limitatore
Retainer	Retenue, dispositif de	Fermo
Retaining	Retenue, de	Sostegno
Return	Retour	Ritorno
Reverse	Inverse	Retromarcia
Reversing	Recul	Inversione di marcia
Right	Droite	Destra
Right Hand Drive (RHD)	Conduite à droite	Guida a destra
Rim	Jante	Bordo
Ring	Bague	Anello
Road	Route	Strada
Rod	Tige	Asta
Rolling	Roulant, de roulement	Rotolante

English	Français	Italiano
Rotary	Rotatif	Rotante
Rotate	Tourner	Ruotare
Rotating	Tournant	Rotante
Rotation	Rotation	Rotazione
Rubber	Caoutchouc	Gomma
<b>S</b>		
Safety	Sécurité	Sicurezza
Scraper	Racleur	Raschietto
Screen	Ecran	Schermo
Screw	Vis	Scheggia
Hex hd (hexagonal head)	Vis à tête 6 pans	Testa esagonale
skt hd (socket head)	Vis à tête creuse	Brugola
csk hd (counter-sunk head)	Vis à tête fraisée	Svasata
Seal	Garniture d'étanchéité	Chiusura ermetica
Sealant	Etanchéifiant	Materiale di tenuta
Sealing	Etanchéité, d'	Sigillante
Seat	Siège	Sedile
Securing	Fixation, de	Fissaggio
Selector Shaft	Levier de commande	Albero selettore
Self Tapping	Auto-taraudeur	Autofilettante
Sender	Expéditeur / Transmetteur	
Sensor	Capteur	Sensore
Separation	Séparation	Separazione
Serial	Série, de	Seriale
Service Exchange (S/EX)	Echange standard	Scambio di servizio
Set screw	Vis de calage	Vite di fermo
Shaft	Arbre	Albero
Shells	Calandres	Gusci
Shield	Ecran	Scudo
Shim	Cale	Zeppa
Shock Absorber	Amortisseur	Ammortizzatore
Shoe	Patin	Scarpa
Short	Court(e)	Ganascia
Shovel	Pelle	Pala
Side Access Door	Porte d'accès latéral	Sportello accesso laterale
Sight	Vue	Mirino
Silencer	Silencieux	Silenziatore
Silicon	Silicone	Silicone
Single	Simple	Singolo
Skirt	Jupe	Bordatura
Slate	Ardoise	Ardesia

English	Français	Italiano
Sleeve	Gaine	Manicotto
Slew	Pivoter	Ruotare
Slewing	Orientation	Rotazione
Sliding	Coulissant	Slittamento
Slotted	Fente, A	Sfinestrato
Small	Petit(e)	Piccolo
Socket	Prise	Presa
Solenoid	Solénoïde / Noyau	Solenoid
Spacer	Pièce d'espacement	distanziatore
Spare	Rechange, pièce de	ricambio
Speakers	Haut-parleurs	altoparlanti
Special	Spécial(e)	speciale
Speed	Vitesse	velocità
Spherical	Sphérique	sferico
Spigot	Goujon / Tube de jonction	zipolo
Spindle	Broche	mandrino
Splined	Cannelé	linguetta
Split Pin	Goupille fendue	coppiglia
Splitter	Répartiteur	diviso
Spray	Pulvérisateur	spray
Spring	Ressort	molla
Stabiliser	Stabilisateur	stabilizzatore
Stabilising	Stabilisation	stabilizzante
Stack	Pile	pila
Standard	Standard	standard
Standpipe	Colonne montante	colonna in aumento
Starter	Démarrreur	starter
Steel	Acier	acciaio
Steering	Direction	lo sterzo
Stem	Tige	Guarnizione
Stiffener	Raidisseur	rinforzo
Stop	Arrêt	fermare
Storage	Rangement	conservazione
Stowage	Arrimage	stivaggio
Straight	Droit(e)	dritto
Strap	Attache	cinghia
Strip	Bande	Cintura
Strut	Jambe	il supporto
Stub	Souche	mozzicone
Stud	Goujon fileté	il perno
Studded	Barrettes, A	costellato
Studding	Colombage	coltellaccio

English	Français	Italiano
Sub Frame	Faux-châssis	sottotelaio
Suction Fan	Turbine d'aspiration	turbina di aspirazione
Suction Nozzle	Buse d'aspiration	ugello di aspirazione
Sump	Carter	i carter
Supply	Fourniture	fornitura
Support	Support	supporto
Suppression	Suppression	repressione
Suspension	Suspension	sospensione
Sweep	Balayage	spazzare
Sweeping	Balayant, de balayage	Formatura a sagoma
Swing	Balancement	Oscillazione
Switch / Switches	Interrupteur / Interrupteurs	Interruttore / Interruttori
Swivel	Pivotant	Parte girevole
System	Système	Sistema
<b>T</b>		
Tab Washer	Rondelle à languettes	Rondella di sicurezza
Tachograph	Tachygraphe	Tachigrafo
Tachometer	Tachymètre	Tacometro
Tandem	Tandem	Tandem
Tank	Réservoir	Serbatoio
Tapered	Conique	Conico
Taper Lock	Verrou conique	Serratura conica
Tee Key	Clé à béquille	Chiave a T
Temperature (Temp)	Température (temp.)	Temperatura (Temp)
Template	Gabarit	Sagoma
Tensioner	Tendeur	Tensiometro
Terminal	Borne	Terminale
Test	Test	Test
Thermostat	Thermostat	Termostato
Thick	Epais	Spesso
Thimble	Dé	Bussola
Thin	Mince	Sottile
Throttle	Accélérateur	Farfalla
Thrust	Poussée	Spinta
Tie Rod	Tirant	Tirante
Tilt	Inclinaison	Inclinazione
Tilting	Inclinable	Inclinazione
Timer	Minuterie	Timer
Timing	Minutage	Temporizzazione
Toggle	Bascule	Ginocchiera
Tool	Outil	Attrezzo

English	Français	Italiano
<b>Toolbox</b>	Boîte à outils	Cassetta attrezzi
<b>Toothed</b>	Dentelé(e)	Dentato
<b>Top</b>	Dessus	Cima
<b>Tow</b>	Remorquer	Rimorchio
<b>Tow Ball</b>	Boule de remorquage	Sfera rimorchio
<b>Tow Bar</b>	Barre de remorquage	Barra rimorchio
<b>Tow Point</b>	Point de remorquage	Punto di rimorchio
<b>Track Rod</b>	Barre d'accouplement	Barra di accoppiamento
<b>Trailer</b>	Remorque	Rimorchio
<b>Transfer Gearbox</b>	Boîte de transfert intermédiaire	Scatola del cambio a trasferimento
<b>Transmission</b>	Transmission	Trasmissione
<b>Travel</b>	Course	Corsa
<b>Trunking</b>	Jonction	Circuito di collegamento
<b>Trunnion</b>	Tourillon	Perno di articolazione
<b>Tube</b>	Tube	Tubo
<b>Tubing</b>	Tubage	Tubazione
<b>Turbocharger (Turbo)</b>	Turbocompresseur	Turbocompressore
<b>Twin</b>	Jumelé	Gemello
<b>Type</b>	Type	Tipo
<b>Typical</b>	Typique	Tipico
<b>Tyre</b>	Pneu	Pneumatico
<b>U</b>		
<b>Uncompressed</b>	Non comprimé	Decompresso
<b>Underside</b>	Dessous	Disotto
<b>Universal Joint (U/J)</b>	Joint universel / Croisillon	Giunto universale
<b>Union</b>	Raccord	Unione
<b>Unit</b>	Unité	Unità
<b>Un-Loader</b>	Déchargeur	Scaricatore
<b>Up</b>	Dessus	Su
<b>Update</b>	Mise à jour	Aggiornamento
<b>Usage</b>	Utilisation	Utilizzo
<b>V</b>		
<b>Valve</b>	Vanne / Soupape	Valvola
<b>Variant</b>	Variante	Variante
<b>Vehicle</b>	Véhicule	Veicolo
<b>Voltage</b>	Tension	Voltaggio
<b>W</b>		
<b>Wander Hose</b>	Flexible aspirateur	Tubo flessibile mobile

English	Français	Italiano
Warning	Avertissement	Avvertenza
Washer	Rondelle	Rondella
Water	Eau	Acqua
Wear	Usure	Usura
Weed Ripper	Désherbage, dispositif de	Sarchiatore
Welded	Soudé	Saldato
Wheel	Roue	Ruota
White	Blanc(he)	Bianco
Wide Sweep	Balayage large	Curvatura larga
Windscreen	Pare-brise	Parabrezza
Wiper	Essuie-glace	Tergicristallo
Wires	Câblage	Fili
Wiring – black, blue, brown, green, grey, orange, pink, purple, red, white yellow	Câblage – noir, bleu, marron, vert, gris, orange, rose, violet, rouge, blanc jaune	Cablaggio Nero, Blu, Marrone, Verde, Grigio, Arancione, Rosa, Porpora, Rosso, Bianco Giallo
Work Light	Lampe de travail	
<b>X</b>		
Xenon	Xénon	Xenon
<b>Y</b>		
Yellow	Jaune	Giallo



English	Español	Svenska
<b>A</b>		
<b>Access</b>	Acceso	Tillgång
<b>Accessories</b>	Accesorios	Tillbehör
<b>Accelerator</b>	Acelerador	Gaspedal
<b>Actuator</b>	Accionador, servomotor	Aktiverare
<b>Adaptor (adapt)</b>	Adaptador (Adapt.)	Övergång
<b>Adapter Flange</b>	Brida del adaptador	Övergångsfläns
<b>Adaptor Plate</b>	Disco del adaptador	Övergångsplatta
<b>Adaptor, Straight</b>	Tramo recto del adaptador	Rak övergång
<b>Adjuster</b>	Regulador	Justering
<b>Adjuster Kit</b>	Juego regulador	Justeringssatts
<b>Adjuster Valve</b>	Válvula del regulador	Ventiljustering
<b>Adjustable</b>	Ajustable	Justerbar
<b>Aerial</b>	Antena	Antenn
<b>Air</b>	Aire	Luft
<b>Air Cleaner</b>	Purificador de aire	Luftrenare
<b>Air Conditioner</b>	Aire acondicionado	Luftkonditionering
<b>Air Cylinder</b>	Cilindro de aire	Luftcylinder
<b>Air Filter</b>	Filtro de aire	Luftfilter
<b>Air Manifold</b>	Distribuidor de aire	Luftfördelare
<b>Air Mass Meter</b>	Medidor de masa de aire	Luftmätare
<b>Air Feed</b>	Inyector de aire	Luftförsörjning
<b>Air Air Chute</b>	Conducto neumático	Dränering
<b>Air Outlet</b>	Salida de aire	Överskottsluft
<b>Air Muffler</b>	Silenciador de aire	Luftljuddämpare
<b>Air Pressure Regulator</b>	Regulador de presión del aire	Luftregulator
<b>Air Ram</b>	Aire a presión	Luftkolv
<b>Air Valve</b>	Válvula de aire	Luftventil
<b>Air Vent Pipe</b>	Tubería del sistema de ventilación	Luftventilsrör
<b>Alternator</b>	Alternador	Generator
<b>Alternator Interface</b>	Acoplamiento del alternador	Generatorfäste
<b>Aluminium (Alum)</b>	Aluminio (Alum.)	Aluminium
<b>Anchor</b>	Anclaje	Ankare
<b>Angle</b>	Ángulo	Vinkel
<b>Antiluce Fastener</b>	Elemento de sujeción "Anti-luce"	Låsbeslag(sidodörr)
<b>Amendment (Amdt.)</b>	Corrección (Correc.)	Rättelse/förbättring
<b>Amplifier</b>	Amplificador	Elektrisk förstärkare
<b>Arrangement</b>	Disposición	Arrangemang
<b>Ashtray</b>	Cenicero	Askkopp
<b>Assembly (Assy)</b>	Conjunto (Conj.)	Sätta ihop

English	Español	Svenska
<b>Auto Blanking</b>	Borrado automático	Automatisk stängning
<b>Automatic</b>	Automático	Automatisk
<b>Auxiliary</b>	Auxiliar	Extra
<b>Axle</b>	Eje	Axel
<b>Axle Beam</b>	Viga del eje	
<b>Axle Bolt</b>	Perno del eje	Axelbult
<b>Axle Breather</b>	Respiradero del eje	
<b>Axle Carrier &amp; Tube</b>	Tubo y soporte del eje	
<b>Axle Front</b>	Frontal del eje	Framaxel
<b>Axle Rear</b>	Trasera del eje	Bakaxel
<b>Axle Washer</b>	Arandela del eje	Axelbricka
<b>B</b>		
<b>Back Plate</b>	Contraplato	Bakstycke
<b>Bag</b>	Bolsa	Säck
<b>Ball</b>	Bola	Kula
<b>Ball End</b>	Lado esférico	
<b>Ball Joint</b>	Rótula	
<b>Ball Valve</b>	Válvula de bola	Kulventil
<b>Bar</b>	Barra	Ramp
<b>Basin</b>	Vasija	Skål
<b>Battery</b>	Batería	Batteri
<b>Battery Housing</b>	Alojamiento de la batería	Batterikåpa
<b>Battery Terminals</b>	Bornes de la batería	Batteriterminal
<b>Battery Lead</b>	Cable de la batería	Batteribly
<b>Battery Tray</b>	Bandeja de la batería	Batteri platta
<b>Beacon</b>	Faro	Varningsljus
<b>Beacon Bar</b>	Barra del faro	Takramp varningsljus
<b>Beam</b>	Haz	Strålkastare
<b>Bearing</b>	Cojinete	Lager
<b>Bell Housing</b>	Carcasa del embrague	Svänghjulskåpa
<b>Bellows</b>	Fuelle	Bälg
<b>Belt</b>	Correa	Remm
<b>Black</b>	Negro	Svart
<b>Blanking</b>	Borrado	Stängning
<b>Bleeper</b>	Emisor de tonos	Backvanare
<b>Blind Rivet</b>	Remache ciego	Popnit
<b>Block</b>	Bloque	Stänga/sätta igen
<b>Blue</b>	Azul	Blå
<b>Board</b>	Tablero	Skiva
<b>Body</b>	Cuerpo	Kropp
<b>Bolt</b>	Perno	Bult

English	Español	Svenska
hex hd (hexagonal head)	cab. hexag. (cabeza hexagonal)	Bult (sexkanthuvud)
skt hd (socket head)	cab. hueca (cabeza hueca)	Bult försänkt huvud
csk hd (counter-sunk head)	cab. avell. (cabeza avellanada)	
Boom	Brazo	Bom
Boost	Empujar	Högeffekt
Bore	Calibre	Borra
Boss	Refuerzo	Knopp
Bottom	Inferior	Nertill
Bottle	Botella	Flaska
Box	Cuadro	Låda
Brace	Abrazadera	Band
Bracket (Brkt)	Soporte (Sop.)	Konsoll
Brake	Freno	Broms
Brass Wing Nut	Tuerca de mariposa de latón	Mässingsvingmutter
Breather	Respiradero	Luftare
Broom	Escobilla	Kvast
Brown	Marrón	Brun
Brush	Escobilla	Borste
Base	Base	Bas
Buffer	Amortiguador	Dämpare
Build	Construir	Bygga
Bulb	Bombilla	Lampa
Bulkhead	Mampara	Skott (i tank)
Bumper	Parachoques	Kofångare
Bump Stop	Tope	Underkörningskydd
Bungee Cord	Cuerda elástica	
Bush	Casquillo	Bussning
Buzzer	Zumbador	Summer
Button	Botón	Knapp
<b>C</b>		
Cab	Cabina	Hytt
Cable	Cable	Wire
Caliper	Calibrador	
Cam Shaft	Árbol de levas	Kamaxel
Camera	Cámara	Kamera
Canopy	Cúpula	Kanape
Cap	Tapa	Kåpa
Capping	Cubierta	
Carabiner	Mosquetón	Karbidhake
Carrier	Soporte	Bärare
Case	Caja	Fall

English	Español	Svenska
Casing	Carcasa	Hölje
Catalogue	Catálogo	Katalog
Catch	Fiador	Fånga
Caution	Precaución	Varning
Centre	Centro	Mitten
Chain	Cadena	Kedja
Chassis	Chasis	Chassie
Check	Control	Kontrollera
Check Valve	Válvula de retención	Kontrollventil
Chute	Conducto	Dränering
Circlip	Resorte circular	Buntband
Circuit	Circuito	Strömkrets
Clamp	Grapa	Klämma
Cleaner	Limpiador	Rengörare
Clevis	Horquilla	
Clip	Pinza	Klämma
Clutch	Embrague	Koppling
Coach	Carrocería	Kaross
Coil	Bobina	Spole
Collar	Casquillo	Krage
Complete	Completo	Slutföra
Components	Componentes	Komponent
Compressor	Compresor	Kompressor
Cone	Cono	Konisk
Connector	Conector	Kontaktor
Connecting	Conexión en curso	Ansluta
Connection	Conexión	Anslutning
Con Rod (Connecting Rod)	Biela (Biela)	
Continued (Cont.)	Continuación (Cont.)	Fortsatt
Control (Cntrl)	Control (Cont.)	Kontroll
Controller	Controlador	Kontrollant
Conventional	Convencional	Vanlig
Conversion (Conv)	Conversión (Conv.)	Omställning
Cooler	Refrigerador	Kylare
Cooling	Refrigeración	Kylning
Copper	Cobre	Koppar
Core	Núcleo	Stomme
Cotter	Chaveta	Sprint/kil
Coupling	Acoplamiento	Koppling
Cover	Cubierta	Skydd
Cowling	Capó	
Crank-case	Cárter	Vevhus

English	Español	Svenska
<b>Cranked</b>	Acodado	Krökt
<b>Cross Member</b>	Travesaño	Tvärstag
<b>Crown Wheel</b>	Corona dentada	Kronhjul
<b>Curb</b>	Borde	Kansten
<b>Cylinder</b>	Cilindro	Cylinder
<b>D</b>		
<b>Damper</b>	Amortiguador	Dämpare
<b>Deflector</b>	Deflector	Riktare
<b>Description</b>	Descripción	Beskrivning
<b>Details</b>	Detalles	Detaljer
<b>Detergent</b>	Detergente	Rengöring
<b>Diagram</b>	Diagrama	Diagram
<b>Dial</b>	Cuadrante	Ring
<b>Diaphragm</b>	Diafragma	Diafragma
<b>Diode</b>	Diodo	Diod
<b>Dipped Beam</b>	Luz de cruce	Halvljus
<b>Dipstick</b>	Varilla de nivel de aceite	Olje/mätsticka
<b>Dipstick guide</b>	Guía de la varilla de nivel de aceite	Markering oljesticka
<b>Dipstick tube</b>	Tubo de la varilla de nivel de aceite	Rör oljesticka
<b>Directional</b>	Direccional	Riktningvisare
<b>Dirt</b>	Suciedad	Smutts
<b>Disc/Disk</b>	Disco	Lamell
<b>Display</b>	Pantalla	Skärm
<b>Distributor</b>	Distribuidor	Distributör
<b>Diverter</b>	Desviador de flujo	Omvändare
<b>Door</b>	Puerta	Dörr
<b>Double</b>	Doble	Dubbel
<b>Dowel</b>	Espiga	Plugg/tapp
<b>Down</b>	Abajo	Ner
<b>Dowty Seal</b>	Junta "Dowty"	
<b>Drag Link Tube</b>	Biela de arrastre	
<b>Drain Plug</b>	Tapón de drenaje	Dräneringsplug
<b>Drive</b>	Transmisión	Köra
<b>Drive Core</b>	Núcleo de la transmisión	Drivaxel
<b>Drive Coupling</b>	Acoplamiento de la transmisión	Drivkoppling
<b>Drive Dog</b>	Retén de la transmisión	
<b>Drive Flange</b>	Brida de la transmisión	Drivfläns
<b>Drive Motor</b>	Motor de la transmisión	Drivmotor
<b>Drive Pump</b>	Bomba de la transmisión	Drivpump
<b>Drive Shaft</b>	Eje de la transmisión	Drivaxel

English	Español	Svenska
Drive Tube	Tubo de la transmisión	
Dual Sweep	Doble barrido	Dubbelsug
Dump Valve	Válvula de descarga	Övertrycksventil
Dust	Polvo	Damm
<b>E</b>		
Earth, electrical (Ground)	Tierra	Jord
Eccentric	Excéntrico	Eccentrix
Elbow	Codo	Vinkel
Electric	Eléctrico	Elektrisk
Electrical	Eléctrico	Elektriska
Element	Elemento	Beståndsdel
Enclosure	Caja	Omgivet
End	Extremo	Slut
End Plate	Placa de tope	Skyddsplatta
End Cap	Tapa de extremo	Skyddskåpa
Engine	Motor	Motor
Exchange	Intercambio	Växla
Exhaust	Escape	Avgaser
Exhaust Gas Recirculation (EGR)	Recirculación de los gases de escape (EGR)	Avgasventil (EGR)
Expansion	Expansión	Expantion
Extended	Extendido	Förlängd
Extension	Extensión	Förlängning
Extinguisher	Extintor	Förlängare
<b>F</b>		
Fan	Ventilador	Fläkt
Fastener	Sujeción	Fäste
Feed	Alimentación	Försörjning
Female	Hembra	Kvinna
Filler	Embudo	Filler
Filter	Filtro	Filter
Finisher	Unidad de acabado	Avslutare
Fire	Fuego	Eld
First	Primero	Första
Fishtail	Cola de pez	fiskstjärt
Fit	Acoplar	Passa
Fitting	Conector	Montering/installation
Fixing	Fijación	Laga
Flange	Brida	Fläns
Flap	Aleta	Dörr / öppning



English	Español	Svenska
Flash	Centelleo	Blixt
Flexible (Flexi)	Flexible (Flex.)	Flexibel
Floor	Piso	Golv
Floorplate	Placa de piso	Golvplatta
Flow	Flujo	Flöde
Fluid	Líquido	Vätska
Flywheel	Volante	Stödhjul
Foam	Espuma	Skumm
Fog	Niebla	Dimma
Foot	Pie	Fot
Forward	Directa	Framåt
Frame	Bastidor	Ram
Front	Delantero	Fram
Fuel	Combustible	Drivmedel
Function	Función	Funktion
Fuse	Fusible	Säkring
<b>G</b>		
Gain	Ganancia	Vinna
Galvanised	Galvanizado	Galvaniserad
Gantry	Pórtico	Brygga/ställning
Gas	Gas	Gas
Gas Strut	Montante de gas	
Gasket	Junta	Packning
Gauge	Indicador	Tryckmätare
Gauze	Tela metálica	Flor(gasbinda)
Gear	Engranaje	Växel
Geared	Accionado por engranaje	Växlad
Gearbox	Caja de cambios	Växellåda
General	General	I allmänhet
Glass	Vidrio	Glas
Glow Plug	Bujía incandescente	Glödstift
Gobbler (Nozzle Tilt)	"Gobbler"	Tilt (sugbox)
Grab	Gancho	Fånga
Grease	Grasa	Smörja
Greaser	Engrasador	Fett
Green	Verde	Grön
Grey	Gris	Grå
Grill	Rejilla	Grill
Grip	Mango	Grepp
Grub Screw	Tornillo de presión	Avdragare
Grommet	Arandela	genomföring
Guard	Protección	Skydd

English	Español	Svenska
Guide	Guía	Guide
<b>H</b>		
Handbrake	Freno de mano	Handbroms
Hand	Manual, a mano	Hand
Hand Primer	Bomba de mano	Handcreme
Hand Wash	Lavado a mano	Handtvätt
Handle	Asa	Handtag/vred
Hanger	Soporte colgante	Hängare
Harness	Mazo de cables	Sele
Head	Cabeza	Huvud
Headlamp	Faro	Strålkastare
Heat	Calor	Värme
Heatshield	Pantalla térmica	Värmeplåt
Heater	Calentador	Värmare
High Pressure	Alta presión	Högtryck
Hi Tip	Punta alta	Högtippande
Hinge	Bisagra	Gångjärn
Hinged	Articulado	Gångjärns hängd
Holder	Portaherramientas	Hållare
Hooks	Ganchos	Krokar
Hopper	Tolva	Behållare
Horn	Claxon	Signalhorn
Hose	Tubo flexible	Slang
Hose Tail	Extremo de tubo flexible	Slangände
Hot	Caliente	Varm
Hour Meter	Cronómetro	Timräknare
Housing	Carcasa	Kåpa/skydd
Hub	Cubo	Centrum
Hydraulic	Hidráulico	Hydraulisk
Hydrant	Boca de riego	Brandpost
Hydrant Filler		Brandpost huvud
Hydrant Hose	Tubo flexible de la boca de riego	Brandpostslang
Hydrostatic	Hidrostático	Hydrostatisk
<b>I</b>		
Identification	Identificación	Identifiering
Idle	Ralentí	Idealisk
Ignition (Ign)	Encendido (Enc.)	Tändning
Illuminated	Encendido	Eliminerad
Illustrated	Ilustrado	Illustrerad
Illustration	Ilustración	Illustration

English	Español	Svenska
<b>Impeller</b>	Propulsor	Impeller
<b>Inclusive</b>	Inclusivo	Inklusive
<b>Information (Info)</b>	Información (Info.)	Information
<b>In</b>	Dentro, entrada	In
<b>Inlet</b>	Admisión	Insläpp
<b>Inlet Cone</b>	Núcleo de admisión	Insläppskona
<b>Inlet Pipe</b>	Tubo de admisión	Insläppsrör
<b>Injection Pump</b>	Bomba de inyección	Injektionspump
<b>Injector</b>	Inyector	Injektor
<b>Injector Pipe</b>	Tubo del inyector	Injektorrör
<b>Input</b>	Entrada	Ingående
<b>Inseal Strip</b>	Banda de estanqueidad	
<b>Insert</b>	Insertar	Lägga till
<b>Insertion</b>	Inserción	Insättande/tillägg
<b>Installation</b>	Instalación	Installation
<b>Instrument</b>	Instrumento	Instrument
<b>Insulator</b>	Aislante	Isolerare
<b>Inter Cooler</b>	Refrigerador intermedio	Laddluftkylare
<b>Interior</b>	Interior	Inredning
<b>Interim</b>	Intermedio	Interim
<b>Internal</b>	Interno	Invändig
<b>Item</b>	Elemento	Punkt/artikel
<b>J</b>		
<b>Jet</b>	Chorro, inyector	Jet
<b>Joint</b>	Articulación	Punkt
<b>Joystick</b>	Palanca de control	Joystick
<b>Jubilee Clip</b>	Pinza "Jubilee"	Slangklämma
<b>Junction</b>	Unión	Korsning
<b>K</b>		
<b>Key</b>	Tecla	Nyckel
<b>Key Switch</b>	Interruptor de llave, llave de contacto	Tändningslås
<b>Kerb</b>	Borde	Kantsten
<b>King Pin</b>	Pivote central	
<b>King Post</b>	Palo macho	
<b>Kit</b>	Juego	Satts
<b>Knob</b>	Mando	Knopp
<b>L</b>		

English	Español	Svenska
label	Etiqueta	Etikett
Lamp	Lámpara	Lampa
Work Lamp	Lámpara de trabajo	Arbetsljus
Head Lamp	Lámpara de cabeza	Strålkastare
Side Lamp	Lámpara lateral	Positionsljus
Lance	Lanza	Munstycke
Lap Joint	Articulación de solape	Fogpunkt
Large	Grande	Stor
Latch	Pestillo	Regla/stänga
Lead	Plomo, avance	Bly
L.E.D. (Light Emitting Diode)	LED (diodo emisor de luz)	L.E.D diod
Leash	Correa	Remm
Left	Izquierda	Vänster
Left Hand Drive (LHD)	Conducción por la izquierda (LHD)	Vänsterstyrning
Leg	Pata	Ben
Length	Longitud	Längd
Lens	Lentes	Glas
Level	Nivel	Nivå
Lever	Palanca	Spak/hävstång
Lid	Tapa	Lock
Lift	Levantar	Lyfta
Lifting	Levantamiento	Lyfter
Light	Luz	Ljus
Side Light	Luz lateral	Sidoljus
Head Light	Faro	Strålkastare
Rear Light	Luz trasera	Bakljus
Brake Light	Luz de freno	Bromsljus
Interior Light	Luz interior	Innebelysning
Fog Light	Luz antiniebla	Dimmljus
Linch Pin	Pasador con anilla abatible	
Lining	Revestimiento interior	Bromsbelägg/beklädnad
Link	Articulación	Länk
Linkage	Varillaje de mando	Länksystem
Litre	Litro	Liter
List	Lista	List
Load	Carga, cargar	Lasta
Located	Situado	Placerad
Lock	Cierre, bloqueo	Lås
Locknut	Contratuerca	Läsmutter
Locker	Taquilla	Skåp
Locking	Cierre	Låsa
Long	Largo	Lång

English	Español	Svenska
Loom	Cableado eléctrico	Hölje
Loop	Bucle	Förbinda
Low Pressure	Baja presión	Lågtryck
Lower	Inferior, bajar	Sänka
Lubricant	Lubricante	Smörjmedel
Lubrication	Lubricación	Smörjning
<b>M</b>		
Machine	Máquina	Maskin
Magnet	Imán	Magnet
Magnetic	Magnético	Magnetisk
Main	Principal	Huvud
Male	Macho	Man
Management	Gestión	Skötsel
Manifold	Distribuidor	Fördelare
Manual	Manual	Manual
Manufactured	Fabricado	Tillverkad
Marker Lamp	Luz de señalización	
Master	Principal	Huvud
Master Cylinder	Cilindro maestro	Huvudcylinder
Maximum (Max)	Máximo (Máx.)	Maximum
Mesh	Malla	Galler
Metal	Metal	Metall
Meter	Metro	Meter
Micro Switch	Microinterruptor	Mikrobrytare
Minimum (Min)	Mínimo (Mín.)	Minimum
Mirror	Espejo	Spegel
Miscellaneous	Varios	Ungefärlig
Modified	Modificado	Modifierad
Module	Módulo	Modul
Monitor	Monitor, controlar	Skärm
Motor	Motor	Motor
Mount	Montura	Montera
Mounted	Montado	Monterad
Mounting	Instalación, soporte	Montera
Mud Flaps	Aleta guardabarros	Stänkskydd
Mud Guard	Guardabarros	Stänkskärm
Muffler	Silenciador	Ljuddämpare
Multi Function	Multifunción, multiuso	Flerfunktion
<b>N</b>		
N/A (Not Applicable)		

English	Español	Svenska
<b>Narrow</b>	Estrecho	Nära
<b>Near side</b>	Lado izquierdo	Nära sidan
<b>Negative</b>	Negativo	Negativ
<b>Neutral</b>	Neutral, punto muerto	Neutral
<b>New</b>	Nuevo	Ny
<b>Nipple</b>	Manguito	Nippel
<b>No. (Number)</b>	Número	Nummer
<b>Non Return</b>	Sin retorno	Ingen återvändo
<b>Normal</b>	Normal	Normal
<b>Note</b>	Nota	Not
<b>Nozzle</b>	Boquilla	Munstycke
<b>Number</b>	Número	Nummer
<b>Numerical</b>	Numérico	Numrerad
<b>Nut</b>	Tuerca	Mutter
<b>Nyloc Nut</b>	Tuerca "Nyloc"	Nylocmutter
<b>Hex Nut</b>	Tuerca hexagonal	Mutter sexkant
<b>Plain Nut</b>	Tuerca lisa	Plan mutter
<b>Self Locking Nut</b>	Tuerca autoblocante	Låsmutter
<b>Thin Nut</b>	Tuerca fina	Mutter (tunn)
<b>Nylon Tube</b>	Tubo de nilón	Nylonslang
<b>O</b>		
<b>Obsolete</b>	Obsoleto	Föråldrad
<b>Off</b>	Apagado	Av
<b>Off Side</b>	Lado derecho	Vid sidan av
<b>Oil</b>	Aceite	Olja
<b>Olive</b>	Oliva	Oliv
<b>On</b>	Encendido	På
<b>Open</b>	Abrir	Öppen
<b>Opened</b>	Abierto	Öppnad
<b>Opening</b>	Apertura, abertura	Öppning
<b>Operating</b>	Funcionamiento	Köra
<b>Option</b>	Opción	Tillbehör
<b>Optional</b>	Opcional	Valfri/frivillig
<b>Orange</b>	Naranja	Orange
<b>Original</b>	Original	Orginal
<b>O Ring</b>	Junta tórica	O ring
<b>Out (Extended)</b>	Fuera	
<b>Outer</b>	Exterior	Yttre
<b>Outlet</b>	Salida	Överskott
<b>Output</b>	Producción	Utkommande
<b>Overhead</b>	En cabeza	Över huvudet



English	Español	Svenska
Overload	Sobrecarga	Överlasta
<b>P</b>		
Packer	Tapón estanco	Packare
Panel	Panel	Panel
Part	Pieza	Del
Pedal	Pedal	Pedal
Pick-up (sensor)	Elegir	Sensor
Pilot (pressure)	Piloto	Pilot (tryck)
Pin	Pasador	Pinne
Pinion	Piñón	Pinjong
Pink	Rosa	Rosa
Pipe	Tubo (rígido)	Rör
Piping	Tubería	Rördragning
Piston	Pistón	Kolv
Pivot	Pivote	Styrtapp
Plastic	Plástico	Plast
Plate	Disco, placa	Tallrik
Plinth	Base	Plint
Plug	Enchufe, tapón	Plugg
Point	Punto	Punkt
Poppet Valve	Válvula de resorte	
Ports	Puertos	Port/öppning
Position	Posición	Position
Positioned	Colocado	Placerad
Post	Poste, borna	Stolpe/stötta
Potentiometer	Potenciómetro	Potensiometer
Power	Potencia	Ström
Pneumatic (See Also Air)	Neumático (véase también Aire)	Pneumatisk
Pressure	Presión	Tryck
Primer	Cebador	Primer
Production	Producción	Produktion
Prop	Apoyo	Stöd/palla under
Propshaft	Árbol de transmisión	Kardanaxel
Pull	Tirar, tracción	Drag
Pulley	Polea	Remskiva
Pulsation	Pulsación	Pulserande
Pulse	Pulso	Puls
Pump	Bomba	Pump
Purple	Púrpura	Lila
Push	Empujar, empuje	Tryck

English	Español	Svenska
<b>Q</b>		
Quick Release	Suelta rápida	Snabbkoppling
<b>R</b>		
Radiator (Rad)	Radiador (Rad.)	Kylare
Raise	Levantar	Lyfta
Raised	Levantado	Lyft
Ram	Pistón	Kolv
Ratio	Relación	Radie
Rear	Trasero	Bak
Red	Rojo	Röd
Reducer	Reductor	Reducerare
Reducing	Reducción, reduciendo	Reducera
Reduction	Reducción	Reducering
Reel	Carrete	Hjul
Refer	Ver	Referera
Refill	Rellenar	Återfylla
Regulator	Regulador	Regulator
Related	Relacionado	Besläktad
Relay	Relé	Relä
Release	Liberación	Lösgöra
Relief Valve	Válvula de descarga	Övertrycksventil
Remote	Remoto	Mottagare
Repair	Reparar	Reparera
Replacement	Sustitución	Ersätta
Resister	Registrar, registro	Motstånd
Restrictor	Estrangulador	Strypning
Retainer	Fiador	Förskottshyra
Retaining	Retención	
Return	Retorno	Återvända
Reverse	Inverso	Backa
Reversing	Inversión	Backa
Right	Derecha	Höger
Right Hand Drive (RHD)	Conducción por la derecha (RHD)	Högerstyrd
Rim	Llanta	Kant/fals
Ring	Anillo	Ring
Road	Carretera	Väg
Rod	Varilla	Rulle
Rolling	Rodamiento	Rullande
Rotary	Giratorio, rotativo	Roterande

English	Español	Svenska
Rotate	Girar	Rotera
Rotating	Giratorio, rotativo	Rotera
Rotation	Giro	Rotation
Rubber	Goma	Gummi
<b>S</b>		
Safety	Seguridad	Säkerhet
Scraper	Escariador	Skrapa
Screen	Filtro, pantalla	Galler
Screw	Tornillo	Skruv
csk hd (counter-sunk head)	Cab. avell. (cabeza avellanada)	
Hex hd (hexagonal head)	Cab. hexag. (cabeza hexagonal)	Skruv sexkant
skt hd (socket head)	Cab. hueca (cabeza hueca)	Skruv (fösänkt)
Seal	Junta	Tätning
Sealant	Sellante	Flytande tätningmedel
Sealing	Sellado	Täta
Seat	Asiento	Säte
Securing	Fijación	Säkra
Selector Shaft	Eje selector	Väljaraxel
Self Tapping	Aterrajado automático	Självdränkande
Sender	Conmutador selector	Sändare
Sensor	Sensor	Sensor
Separation	Separación	Separerat
Serial	Serie	Serie
Service Exchange (S/EX)	Intercambio de servicio	Utbytesdel
Setscrew	Tornillo de fijación	Sättskruv
Shaft	Eje	Skaft
Shells	Cuerpos	Snäckor
Shield	Protector	Skjöld
Shim	Suplemento	Shims
Shock Absorber	Amortiguador	Stötdämpare
Shoe	Zapata	Sko
Short	Corto	Kort
Shovel	Pala	Skyffel
Side Access Door	Puerta de acceso lateral	Sidodörr
Sight	Vista	Sikt
Silencer	Silenciador	Ljuddämpare
Silicon	Silicona	Silikon
Single	Único, sencillo	Enkel
Skirt	Faldón	Kjol
Slate	Pizarra	

English	Español	Svenska
Sleeve	Manguito	Muff
Slew	Pivotar	Svänga/slira
Slewing	Pivotaje	Svängande/slirande
Sliding	Deslizamiento	Glidande
Slotted	Ranurado	Spräckt
Small	Pequeño	Liten
Socket	Casquillo	Socket
Solenoid	Solenoid	Solenoid
Spacer	Separador	Distans
Spare	Repuesto	Reserv
Speakers	Altavoces	Högtalare
Special	Especial	Special
Speed	Velocidad	Fart
Spherical	Esférico	Klotformig
Spigot	Espiga	Rör
Spindle	Husillo	Spindel
Splined	Acanalado	Flisad/splittrad
Splinter	Partícula	Skärva/splitter
Split Pin	Chaveta hendida	Låspinne
Splitter	Separador	Fördelare
Spray	Pulverizador, rociador	Spaya
Spring	Muelle	Fjäder
Stabiliser	Estabilizador	Stabiliserare
Stabilising	Estabilización	Stabilisera
Stack	Pila	Fullpropad med
Standard	Estándar	Standard
Standpipe	Tubo vertical	Vattenpost
Starter	Motor de arranque	Startmotor
Steel	Acero	Stål
Steering	Dirección	Styrning
Stem	Vástago	Stoppa
Stiffener	Contrafuerte, larguero	Förtjockare
Stop	Parar	Stopp
Storage	Almacenamiento	Lagra
Stowage	Estiba	Stuvningsutrymme
Straight	Recto	Rakt
Strap	Tira de sujeción	Sätta fast
Strip	Banda	Ta bort
Strut	Puntal	Balk/stötta
Stub	Tope	Stump/talong
Stud	Espárrago	
Studded	Con pasador	

English	Español	Svenska
<b>Studding</b>	Pasante	
<b>Sub Frame</b>	Bastidor auxiliar	Underram
<b>Suction Box</b>	Caja de succión	
<b>Suction Fan</b>	Ventilador de succión	Sugfläkt(turbin)
<b>Suction Nozzle</b>	Boquilla de succión	Sugmunstycke
<b>Sump</b>	Sumidero	Oljetråg
<b>Supply</b>	Suministro	Förse
<b>Support</b>	Asistencia, soporte	Stödja
<b>Suppression</b>	Supresión	Undertryck
<b>Suspension</b>	Suspensión	Fjädring
<b>Sweep</b>	Barrido	Sopa
<b>Sweeping</b>	Barrido, barriendo	Sopa
<b>Swing</b>	Oscilación	Svänga
<b>Switch</b>	Interruptor	Brytare
<b>Switches</b>	Interruptores	Brytare
<b>Swivel</b>	Giratorio	Svängbar
<b>System</b>	Sistema	System
<b>T</b>		
<b>Tab Washer</b>	Arandela con lengüeta	
<b>Tachograph</b>	Tacógrafo	Färdskrivare
<b>Tachometer</b>	Tacómetro	Hastighetsmätare
<b>Tandem</b>	Tándem	Tandem
<b>Tank</b>	Tanque	Tank
<b>Tapered</b>	Cónico	Avsmalnande
<b>Taper Lock</b>	Cierre cónico	Plugg
<b>Tee Key</b>	Llave en T	Gren
<b>Temperature (Temp)</b>	Temperatura (Temp.)	Temperatur
<b>Template</b>	Plantilla	Mall
<b>Tensioner</b>	Tensor	Sträckare
<b>Terminal</b>	Terminal	Terminal
<b>Test</b>	Prueba	Test
<b>Thermostat</b>	Termostato	Termostat
<b>Thick</b>	Espeso	Tjock
<b>Thimble</b>	Dedal	Fingerborg
<b>Thin</b>	Delgado	Smal
<b>Throttle</b>	Regulador de gases	Trottel
<b>Thrust</b>	Empuje	Tryck
<b>Tie Rod</b>	Barra de acoplamiento transversal de la dirección	
<b>Tilt</b>	Inclinar	Tilt
<b>Tilting</b>	Inclinación	Tilta

English	Español	Svenska
Timer	Temporizador	Timer
Timing	Sincronización	Tids anpassa
Toggle	Báscula	Vippa
Tool	Herramienta	Verktyg
Toolbox	Caja de herramientas	Verktygslåda
Toothed	Dentado	Signalhorn
Top	Superior	Topp
Tow	Remolque	Dra / bogsera
Tow Ball	Bola de remolque	Dragkula
Tow Bar	Barra de remolque	Dragkrok
Tow Point	Punto de remolque	Dragpunkt
Track Rod	Tirante transversal	
Trailer	Remolque	Släp
Transfer Gearbox	Caja de cambios transferencia, caja transfer	Tillsattsväxellåda
Transmission	Transmisión	Transmission
Travel	Recorrido, viaje	Resa
Trunking	Unión	
Trunnion	Muñón	
Tube	Tubo	Rör
Tubing	Sistema de tuberías	Rördragning
Turbocharger (Turbo)	Turbocompresor (Turbo)	Turbo
Twin	Gemelo, bimotor	Dubbel
Type	Tipo	Typ
Typical	Típico	Typisk
Tyre	Neumático	Däck
<b>U</b>		
Uncompressed	No comprimido	Okomprimerad
Underside	Inferior	Undersida
Universal Joint (U/J)	Junta cardánica (U/J)	Knutkors
Union	Unión	Förena
Unit	Unidad	Del
Un-Loader	Descargador	Avlastning
Up	Arriba	Upp
Update	Actualizar	Uppdatera
Usage	Uso	Andvändning
<b>V</b>		
Valve	Válvula	Ventil
Variant	Variante	Variant
Vehicle	Vehículo	Fordon



English	Español	Svenska
Voltage	Tensión	Volt
<b>W</b>		
Wander Hose	Tube flexible móvil	Sugslang (lövsug)
Warning	Advertencia	Varning
Washer	Arandela	Bricka
Water	Agua	Vatten
Wear	Desgaste	Slitage
Weed Ripper	Escardador	Ogräs
Welded	Soldado	Svetsad
Wheel	Rueda	Hjul
White	Blanco	Vit
Wide Sweep	Barrido amplio	Vals
Windscreen	Parabrisas	Vindruta
Wiper	Limpiaparabrisas	Torkare
Wires	Cables	Ledningar
Wiring	Cableado	Ledningsdragning
Black, Blue, Brown, Green, Grey, Orange, Pink, Purple, Red, White Yellow	Negro, Azul, Marrón, Verde, Gris, Naranja, Rosa, Púrpura, Rojo, Blanco Amarillo	Svart Blå Brun Grön Grå Orange Rosa Lila Röd Vit Gul
Work Light	Lámpara de trabajo	Arbetsljus
<b>X</b>		
Xenon	Xenón	Xenon
<b>Y</b>		
Yellow	Amarillo	Gul
Yoke	Horquilla	Sammankoppla





Scarab Sweepers Limited  
Pattenden Lane - Marden - Kent TN12 9QD, UK  
T: +44 (0)1622 831 006  
E: [scarab@scarab.fayat.com](mailto:scarab@scarab.fayat.com) - W: [scarab-sweepers.com](http://scarab-sweepers.com)  
Registered in England No. 18923459 - VAT No. GB 374 5002 68  
Registered Office: Pattenden Lane, Marden, Tonbridge, Kent TN12 9QD, UK